

Architecture of the System for Beam Loss Monitoring and Measurements Under Development for the Injector Complex at CERN

C. Zamantzas, M. Alsdorf, B. Dehning, S. Jackson, M. Kwiatkowski, W. Viganò

CERN, 1211 Geneva 23, Switzerland

Abstract: The strategy for beam setup and machine protection of the accelerators at the European Organisation for Nuclear Research (CERN) is mainly based on its Beam Loss Monitoring (BLM) systems. For their upgrade to higher beam energies and intensities, a new BLM system is under development with the aim of providing faster measurement updates with higher dynamic range and the ability to accept more types of detectors as input compared to its predecessors. In this paper, the architecture of the complete system is explored giving an insight to the design choices made to provide a highly reconfigurable system that is able to fulfil the different requirements of each accelerator using reprogrammable devices.

BLM System Overview

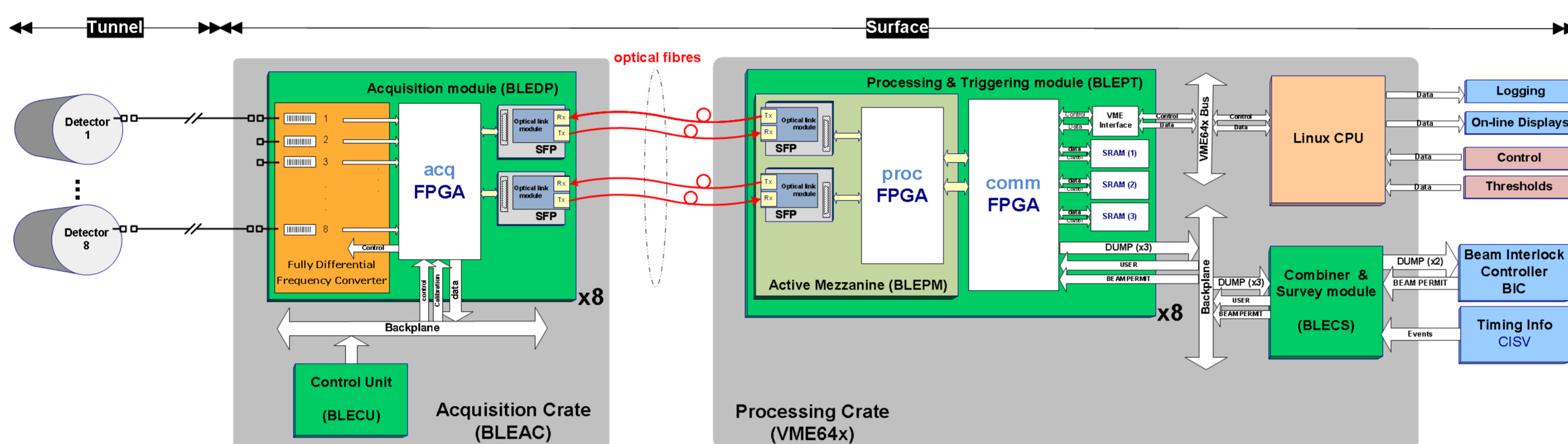

The acquisition part provides the ability to accept several detector types as input. The acquisition cards, called *BLEDPs*, acquire and digitise the data from the detectors and transmit those at the processing crate using *Gigabit Optical Links*. There, the data processing cards, named *BLEPTs*, receive those data and decides whether or not the beam should be permitted to be injected or continue circulating. Each processing module receives data every $2\mu\text{s}$, it can treat up to 8 channels simultaneously, and provides data for on-line display and long-term storage for off-line analysis.

Rack Configuration

The Rack configuration deployed in the different areas accommodates:

- one acquisition crate,
- one processing crate,
- two Beam Interlock User Interfaces and
- a high-voltage power supply, needed for the detectors.

The data connection between the crates is done with multi-gigabit optical links.

For the management of the signal cables a dedicated panel is used.

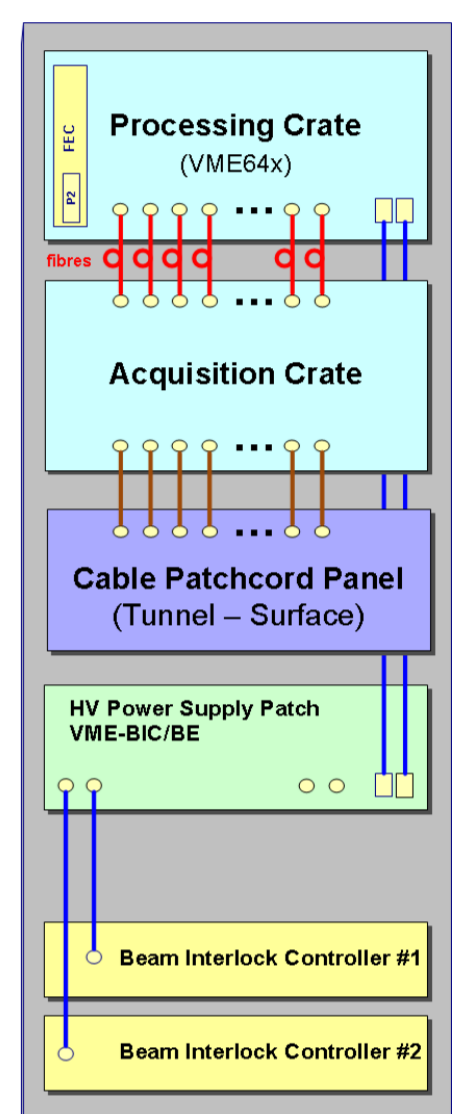

Acquisition

The acquisition crate (BLEAC) can support up to eight acquisition modules. It is based on a custom designed backplane that provide connection for 64 input channels and to each inserted module the needed connection to the power supply voltages and control signals.

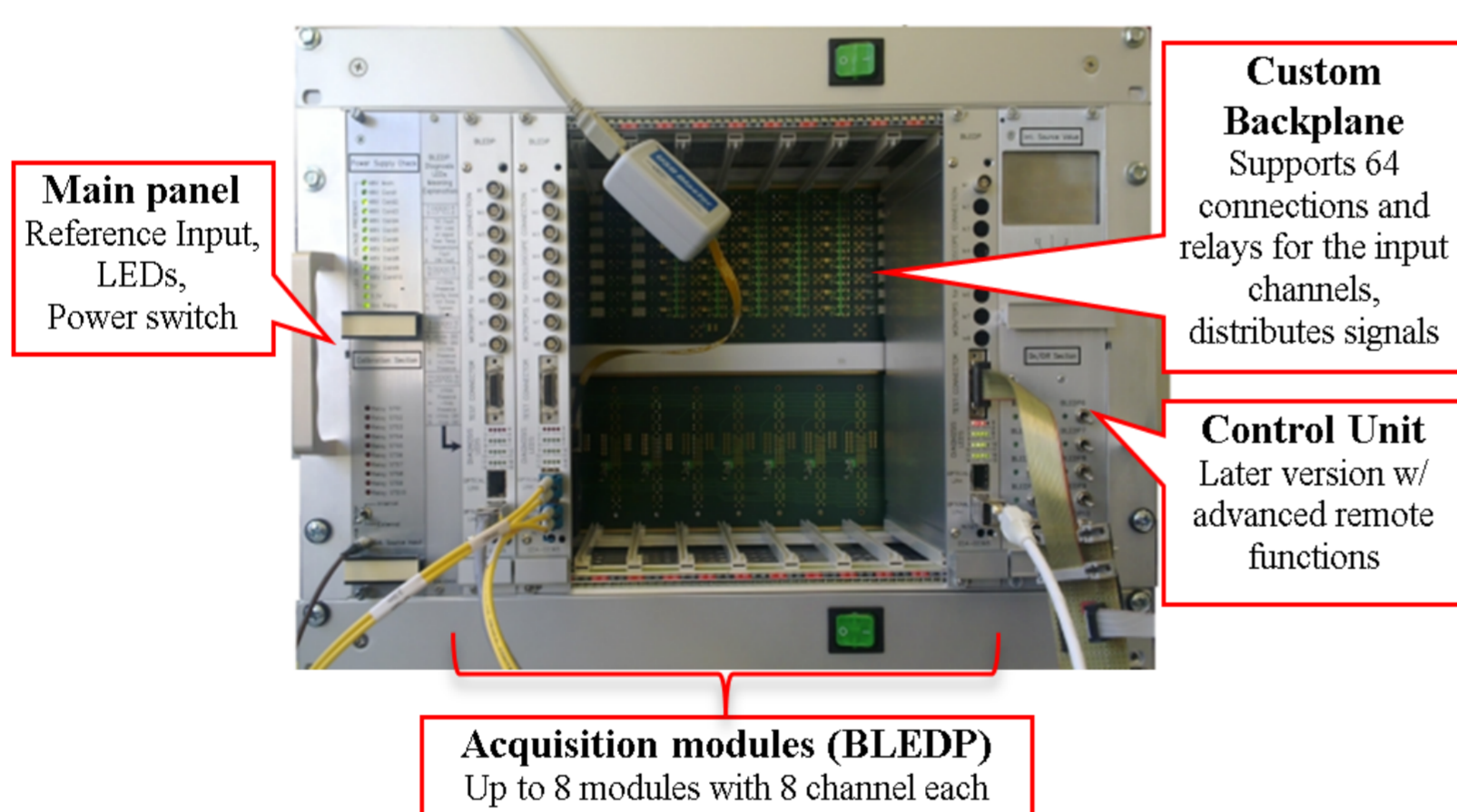

The measurement of the input current is performed by two different techniques:
 a) **Dual Polarity Current to Frequency Converter** used in the range $10\text{pA} - 30\text{mA}$
 b) **Direct ADC acquisition** used in the range $20.3\mu\text{A} - 200\text{mA}$

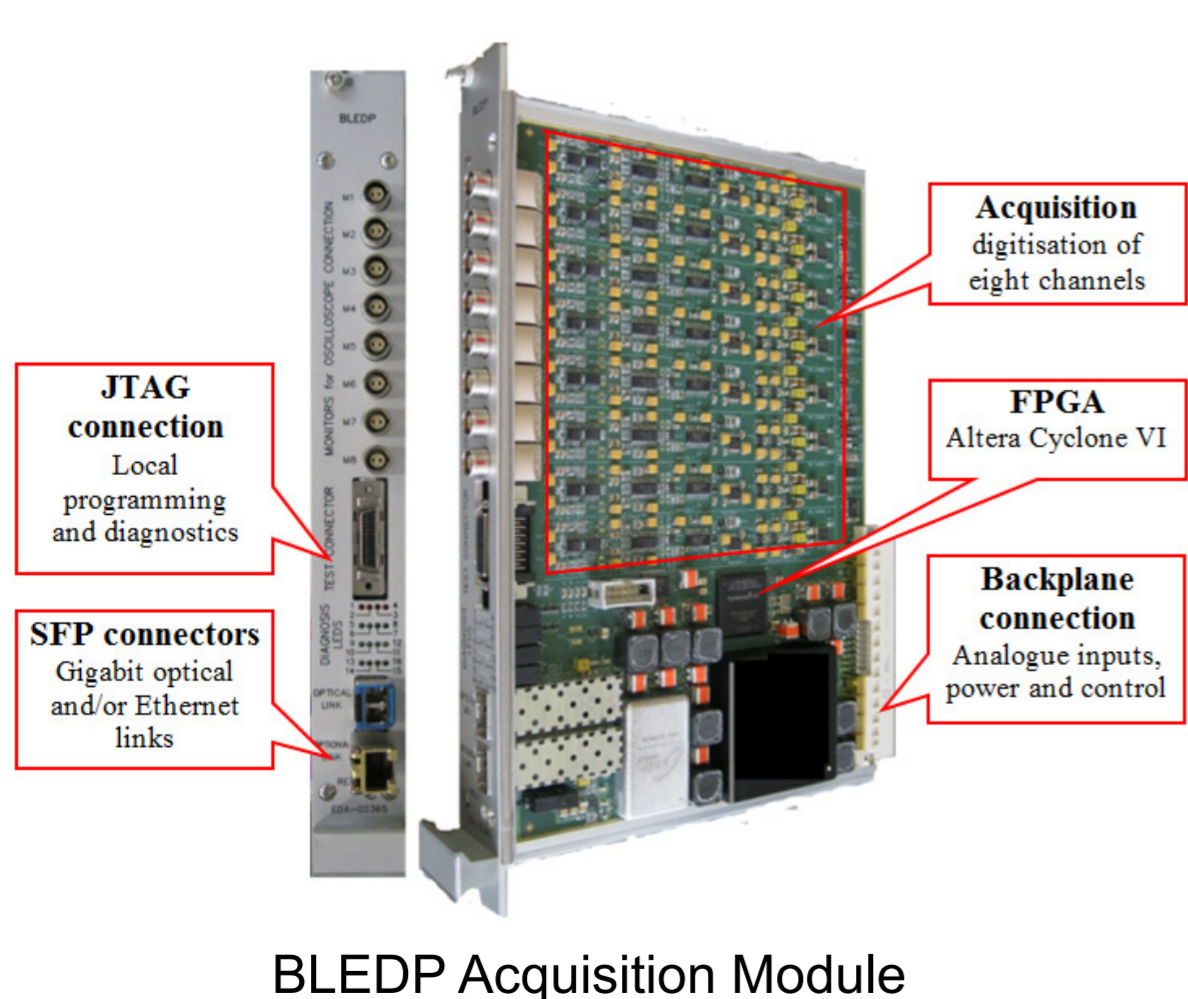

BLEDP Acquisition Module

The control operations of the analogue circuitry are handled by the **FPGA device**:

- defines the start and stop of the acquisition period,
- keeps a count of the number of pulses occurred,
- directs which acquisition technique is active,
- clocks the ADC circuitries and
- makes differences of the recorded ADC values.

Finally, it processes the data by merging the values acquired in the counter and the ADCs and provides the **$2\mu\text{s}$ integral** per channel.

Signal and Power Connections

- All cables pass through enclosed cable-trays.
- Screen of HV cable is open on the detector side to assure there is **no ground loop**.
- Signal line uses **coaxial double shielded cable**
 - Internal screen to **shield low frequency noise**
 - External screen to **shield high frequency noise**

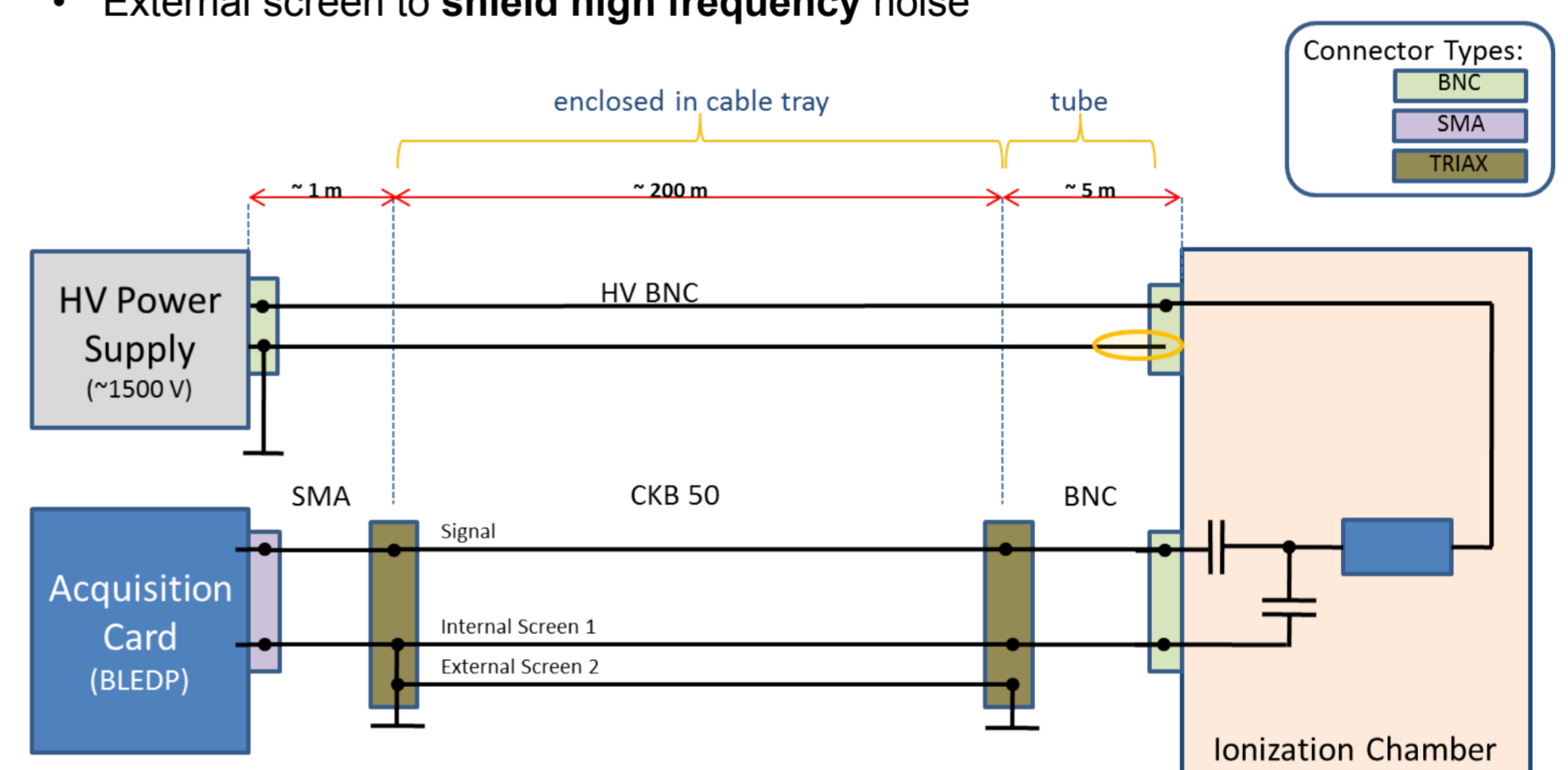

Processing

Each VME64x crate accommodates up to **eight processing and triggering (BLEPT)** modules.

- These modules are comprised by
- the standard CERN BI carrier boards, i.e. the VME64x and
 - an active mezzanine board

The mezzanine comes with an FPGA, i.e. Altera's Cyclone IV with 150K logic elements and provides two SFP modules that can be configured as bidirectional multi-gigabit Optical links or gigabit Ethernet.

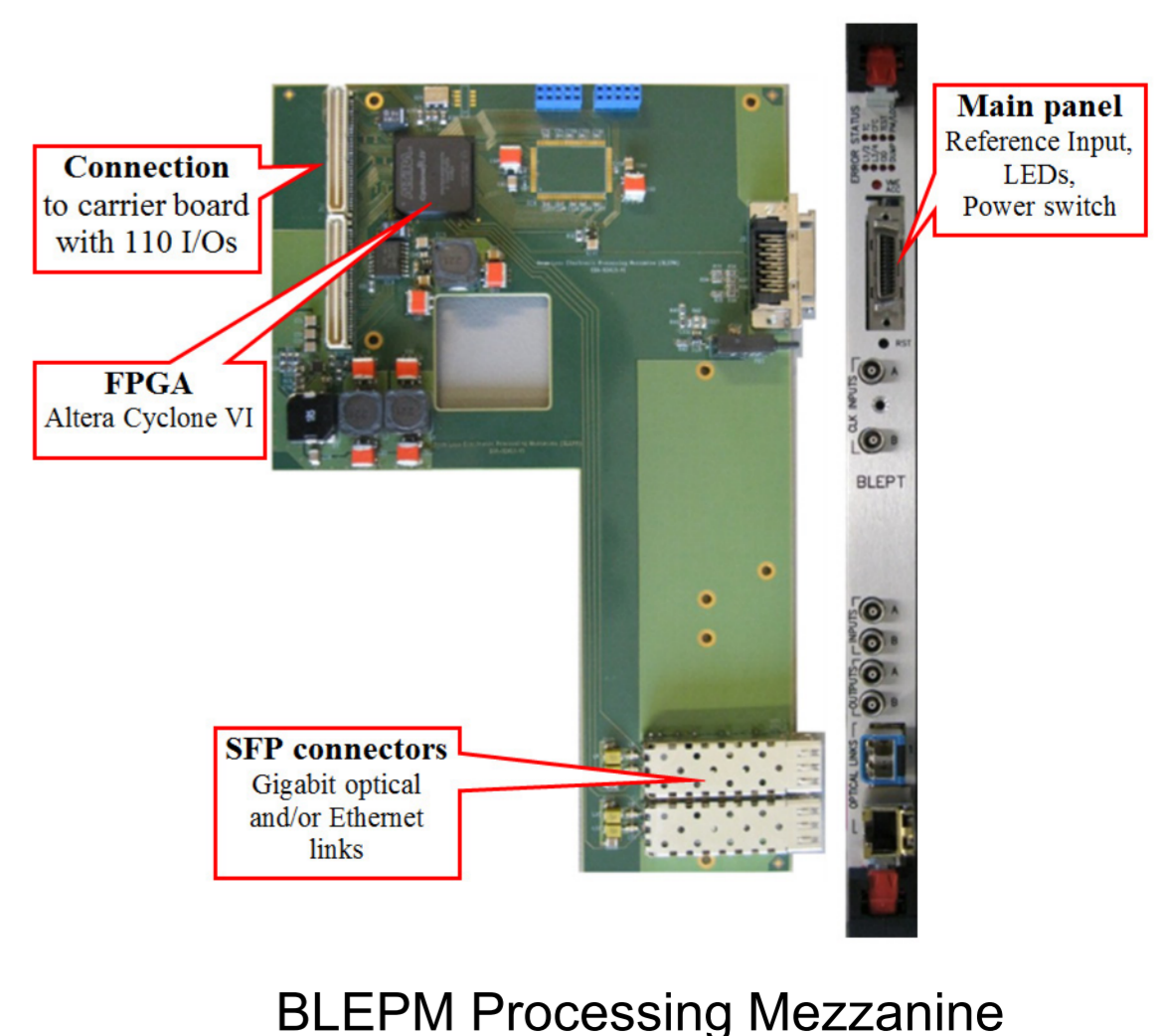

BLEPM Processing Mezzanine