

Alignment & Metrology - Requirements and Realisation

Dominique Missiaen
Survey and Alignment team



ENGINEERING
DEPARTMENT

Introduction

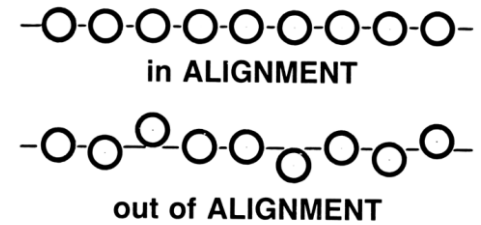

- What does alignment mean?
 - According to the Oxford dictionary: “an arrangement in which two or more things are positioned in a straight line”
 - In the context of particle accelerators, the things are: beam instrumentation & vacuum devices, magnets, RF components, etc.
- Why aligning components?
 - Accelerators have to be aligned within given tolerances to make the beam pass through At least the first time
 - The Earth and the civil engineering works on which we build accelerators is in constant motion

Agenda

- Alignment tolerances
- The ingredients for an accurate alignment
- How do we proceed ?
- Permanent monitoring sensors
- Future colliders requirements
- Conclusions

Alignment tolerances

- Alignment tolerances [Fisher] [Ruland]
 - Error of placement which, if exceeded, lead to a machine that is uncorrectable – with an unacceptable loss of luminosity
- Two types
 - The «absolute»: the accuracy over the whole size of a project (as an example deviation to a nominal plane in vertical direction and to the nominal radial R for a circular collider)
 - Not so critical for physics (typically several mm are requested)
 - The «relative»: the differential variations between several consecutive magnets.
 - This latter type of error has a more direct effect on the closed orbit of the particles.

Plane of a collider

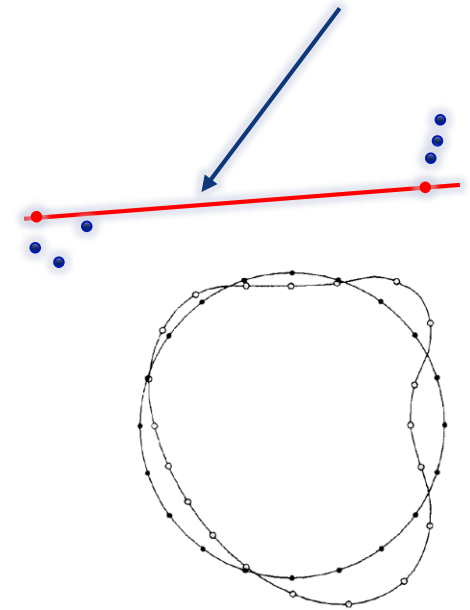

—●— = nominal position
- - -○- - = actual position

[Schwarz]

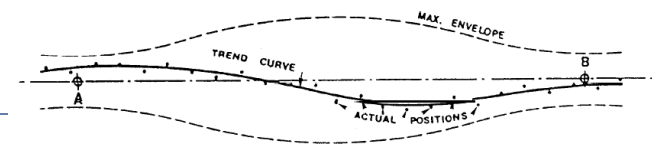
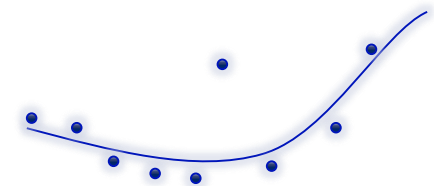

[Mayoud]

Position of magnets with respect to theoretical orbit

History of «relative» tolerances

Accelerator collider	epoch	Radius/ Circumference	Vertical (mm) @1 σ	transversal(m m) @1 σ
PS ring	50's	100m/650m	0.3	0.6
SPS	70's	1km/6km	0.2	0.2
LEP(e+e-)	80's	5km/27km	0.2-0.3	0.2-0.3
LHC (hh)	90's	5km/27km	0.15	0.15
CLIC (e+e-)	2040?	2*25 km	17 microns radially*	
FCC (hh)	2040?	16km/100km	0.2 (0.5*)	0.2 (0.5*)
FCC (ee)	2040?	16km/100km	0.1*	0.1*

* All errors included

- This is not the type of accuracy the surveyors are used to deal with. Most of the time, new instruments and techniques are developed to achieve it

What do we need ?

- Geodetic considerations
 - The Geodetic Networks
 - The co-ordinate systems
- The theoretical trajectory
- The objects to align
 - Fiducials and supporting



Instruments and techniques

Geodetic considerations

Geodetic considerations

- A Global Coordinate System (Cern Coordinates System as an example)
 - Cartesian system XYZ
- A Geodetic Reference Frame
 - Reference surface which is fitting the shape of the earth
 - Depends on the accuracy requested
 - And of the size of the project
 - For the PS Ring : a plane was chosen

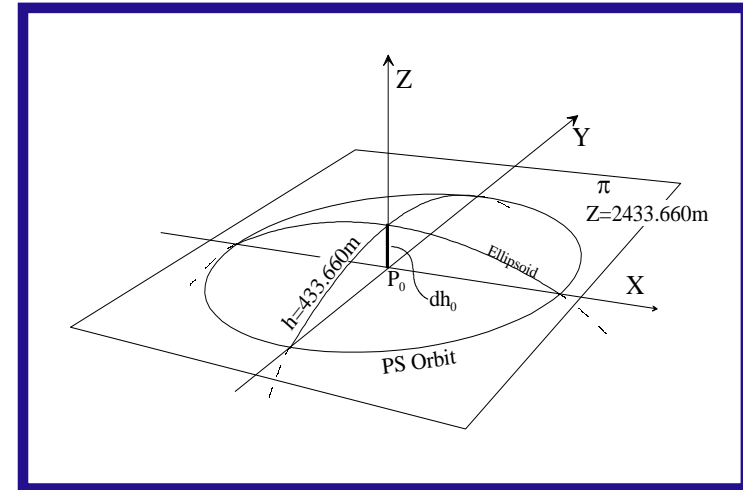

Geodetic considerations

- For the SPS (6km) : a sphere was taken
 - A new coordinate : H height wrt the sphere
- For the LEP/LHC : an ellipsoid was determined

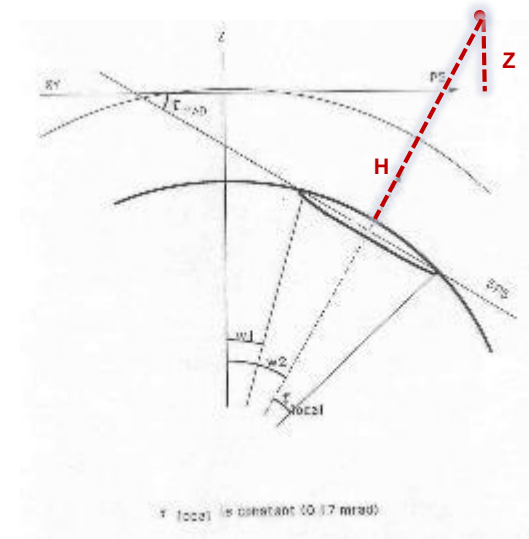
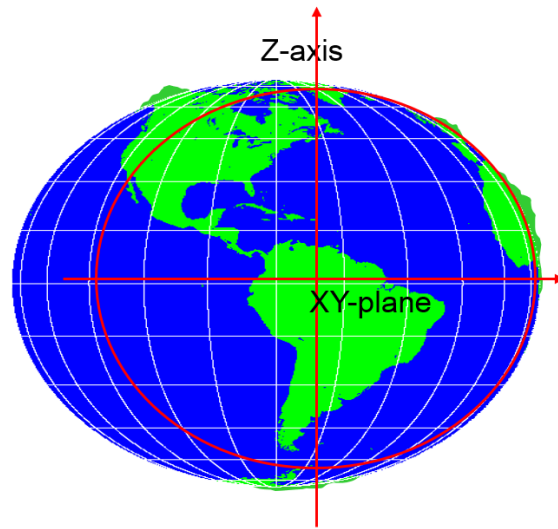
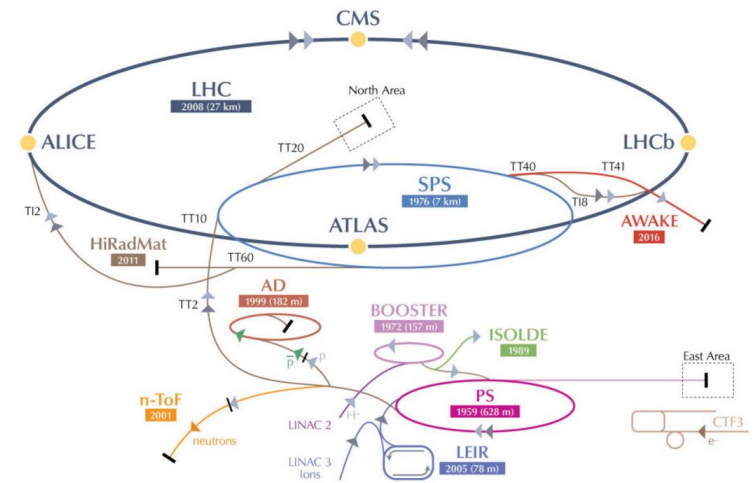

Geodetic considerations

- In presence of mountains, valleys or rock of various density, the plumb line is not perpendicular to the ellipsoid
- The deviation of the vertical is the difference between the perpendicular to the ellipsoid and the plumb line direction
- It is determined by zenithal camera measurements
- Completed by gravimetry measurements, we obtain a GEOID :

Mean sea level equipotential surface of gravity

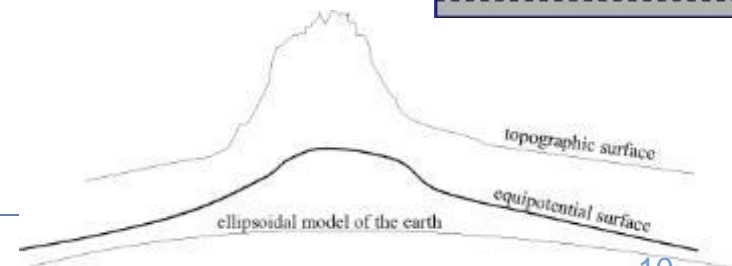
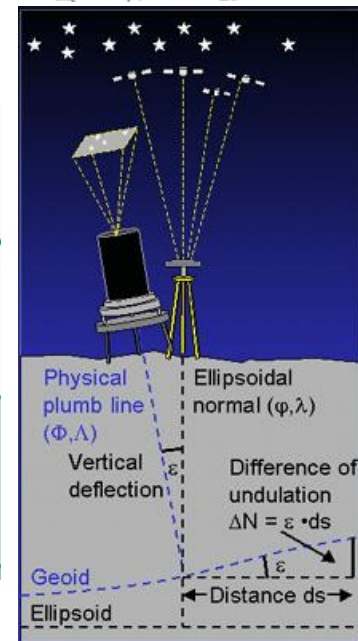
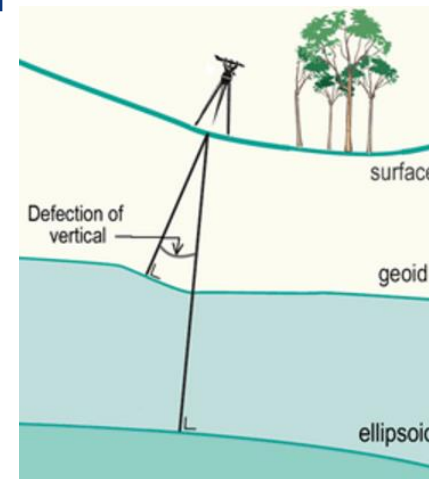

Geodetic considerations

- At CERN
 - Reference frame is an ellipsoid tangent to the earth @ P_0
 - Geoid
 - 1985 : determined for LEP and still used for the LHC
 - 2000 : determined for the CNGS project
 - Global co-ordinate system is CCS
 - Plane of the PS

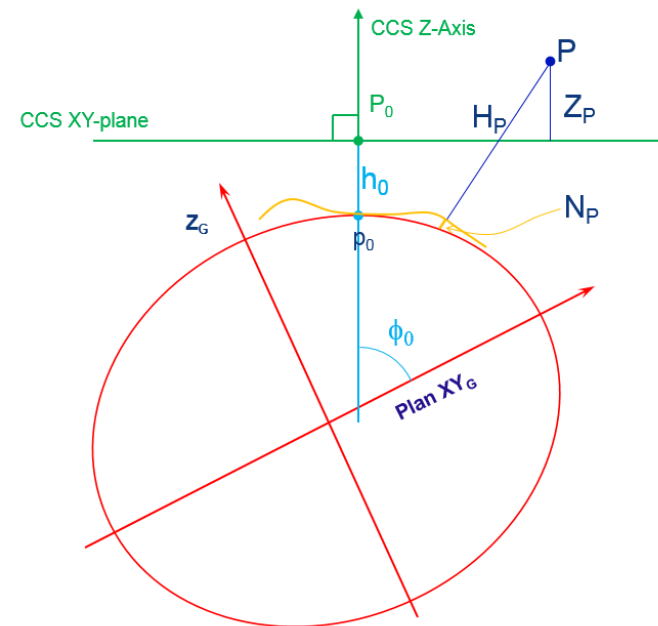

Geodetic considerations

- Impact on construction

- Accelerators built in a tangential plane (slightly tilted to accommodate geological deformations)
- All points around an untilted circular machine lie at the same height.
- Linear machines cut right through the equipotential iso-lines:
 - Center of a 30 km linear accelerator is 17 m below the end points
 - One solution to accommodate

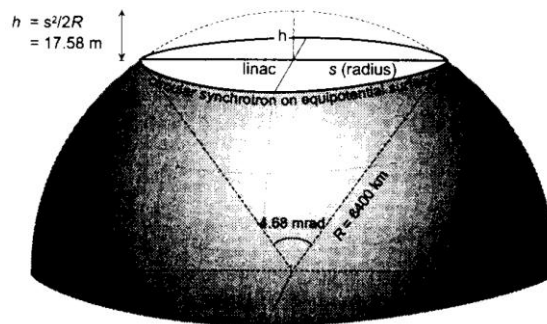

[Ruland]

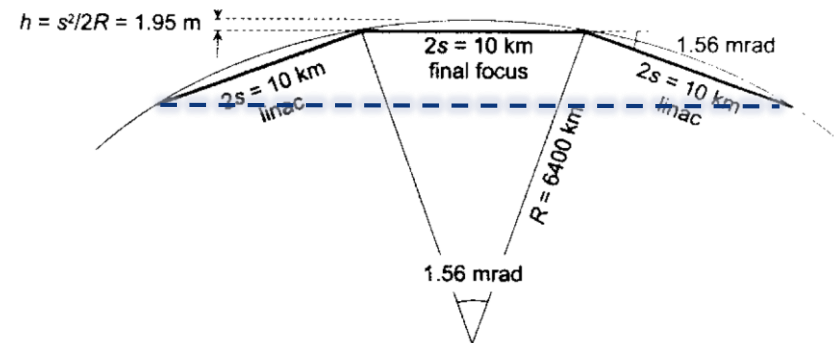

Effect of earth curvature on linear and circular accelerators

Three plane lay-out

The Surface Geodetic Network

- The surface network is indispensable because it can be determined very accurately thanks to GNSS and very accurate distances
- The accuracy of all network points is 2-3 mm

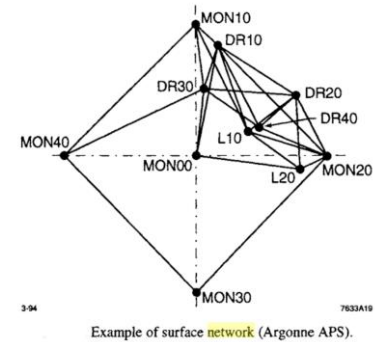

Argonne [Ruland2]

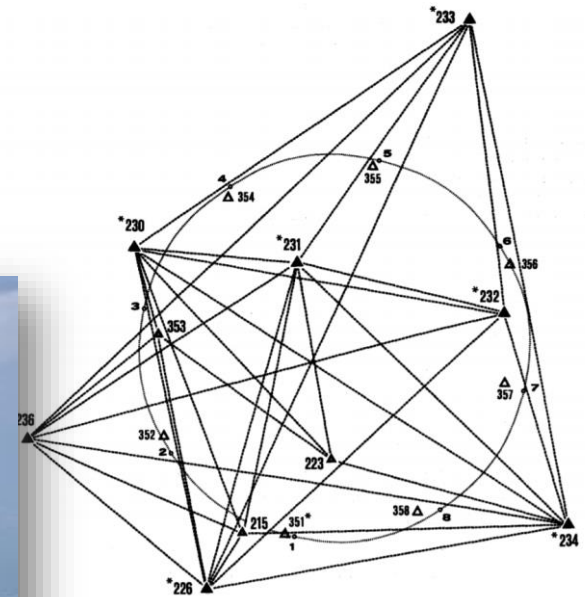

CERN [Mayoud]



The transfer of the Surface geodetic network

- It is realised using a combination of several methods and instruments, among which :
 - Nadiro-zenithal telescopes
 - Plumb lines
 - Distance and H and V angle measurements
 - Accuracy better than 1mm for 100 m depth

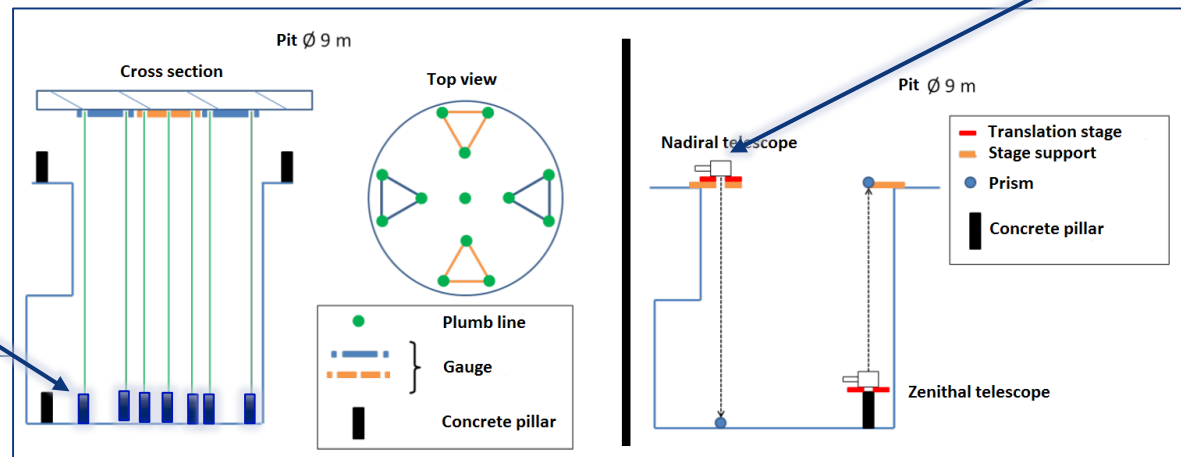
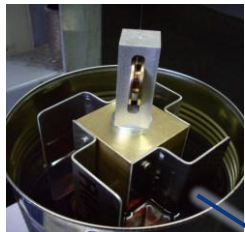
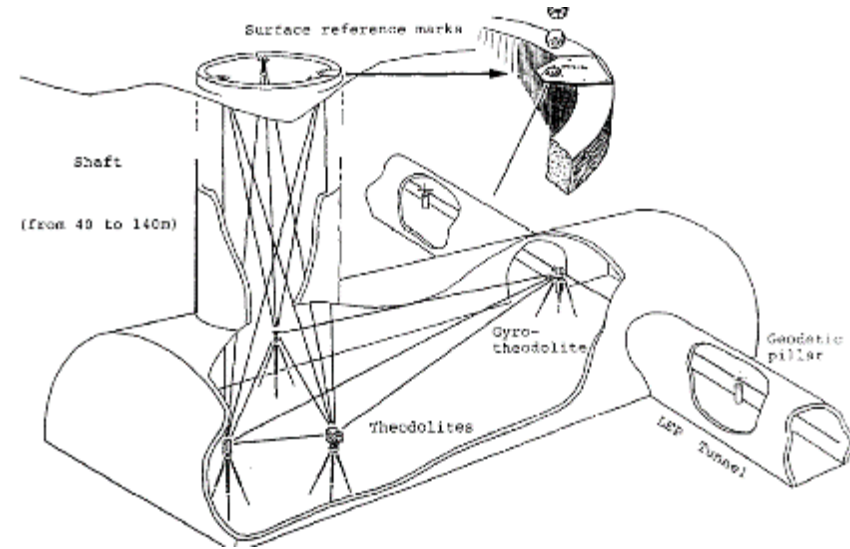

The underground geodetic network

- A network of points is installed preferably in the walls and in the floor of tunnels
- Unfortunately due to tunnel configuration they have a long and narrow shape which is not optimal for its determination
 - Refraction errors

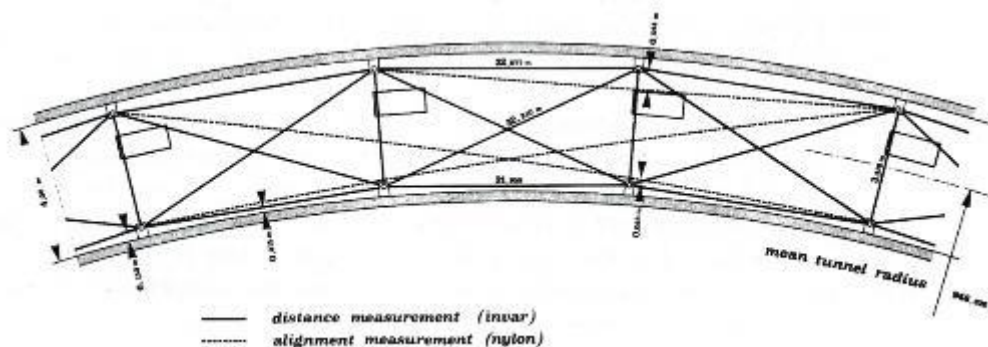
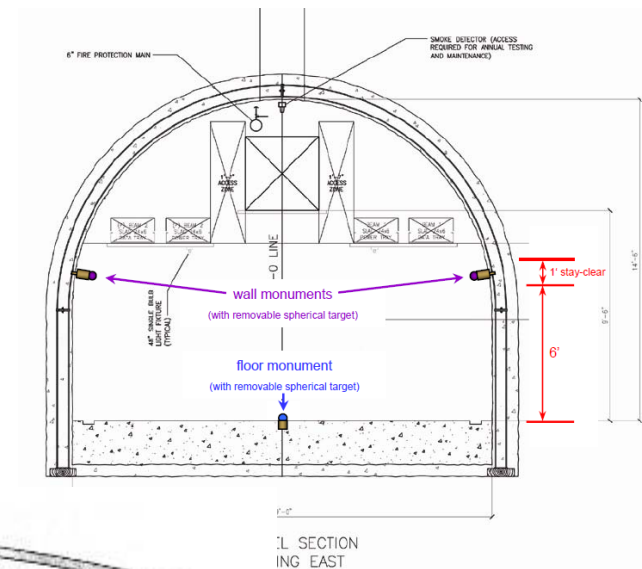
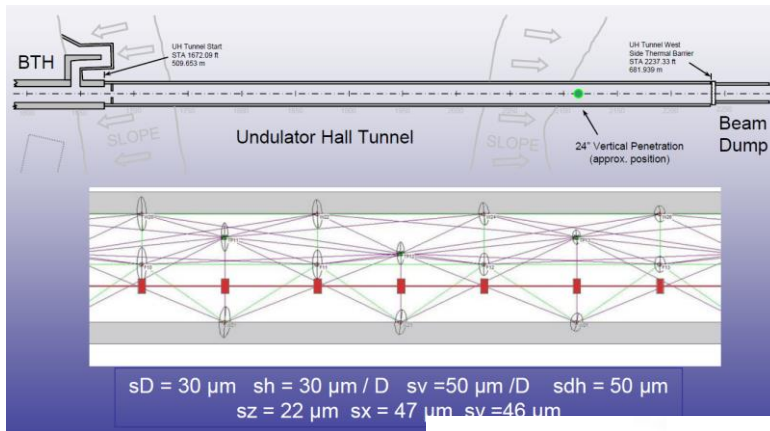

The underground geodetic network

- The determination is done with using angle and distance measurements and orientations w.r.t. the geographic North.
- In vertical optical and digital levels
- The absolute accuracy of 3-4 mm along 3 km
- The relative accuracy in planimetry between 3 consecutive monuments of 0.3 mm.

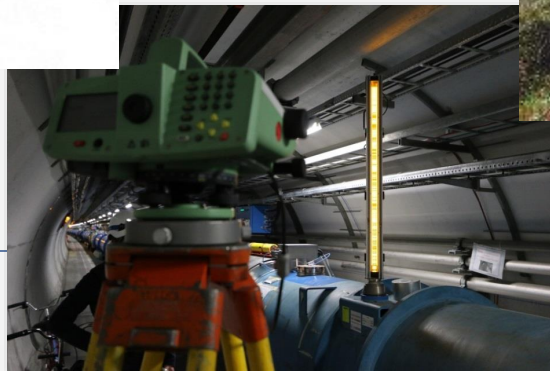
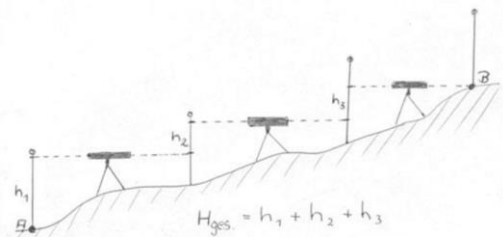

The theoretical trajectory

- It is defined by the Physics using the MADx software
 - First in a horizontal local co-ordinates system xyz
 - Then in the Global Co-ordinates System XYZ
 - From 3 translations and 2 rotations provided by the Survey team
 - Using the SURVEY output function from MADx

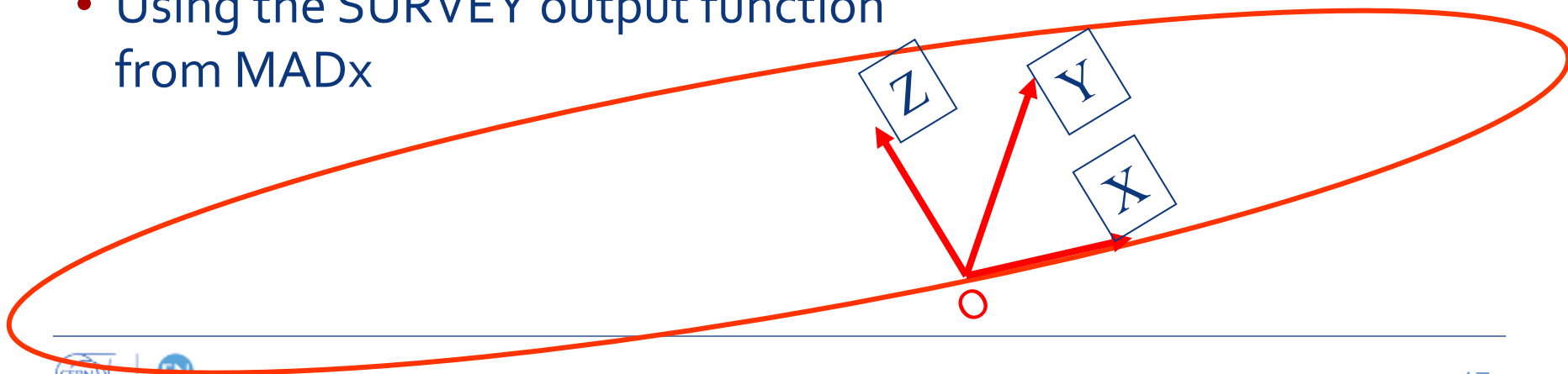
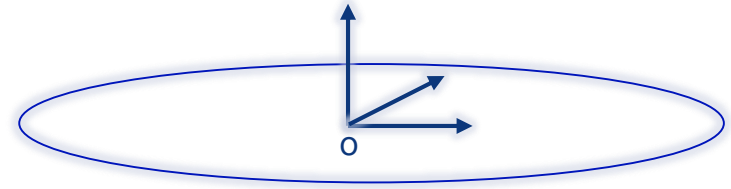

The objects to align

The objects to align

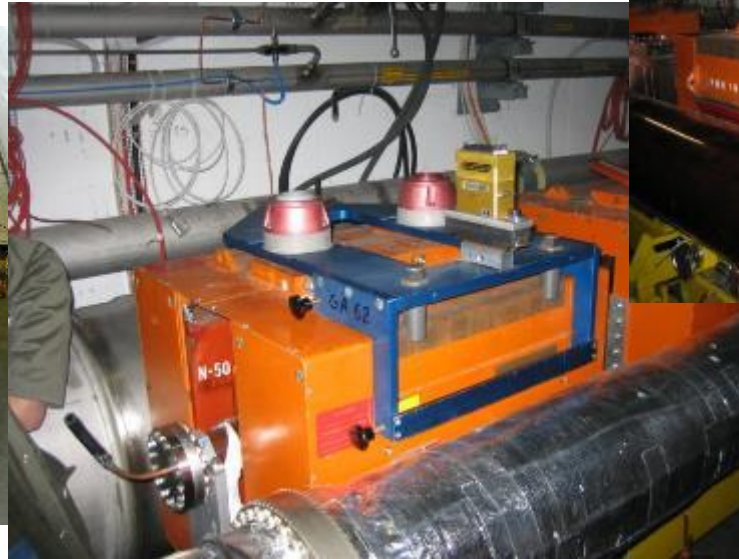
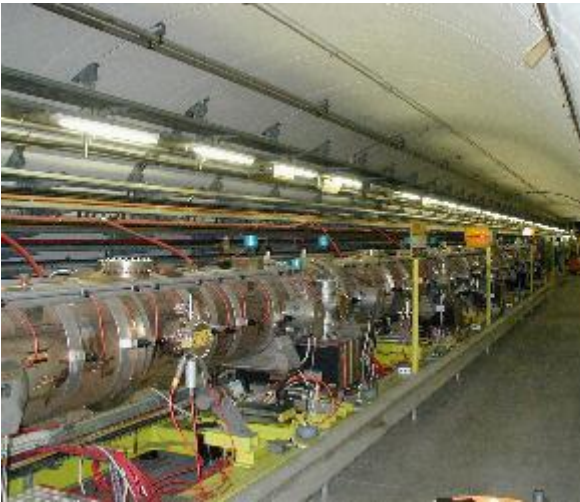

- Nests or corner cube supports are more and more used

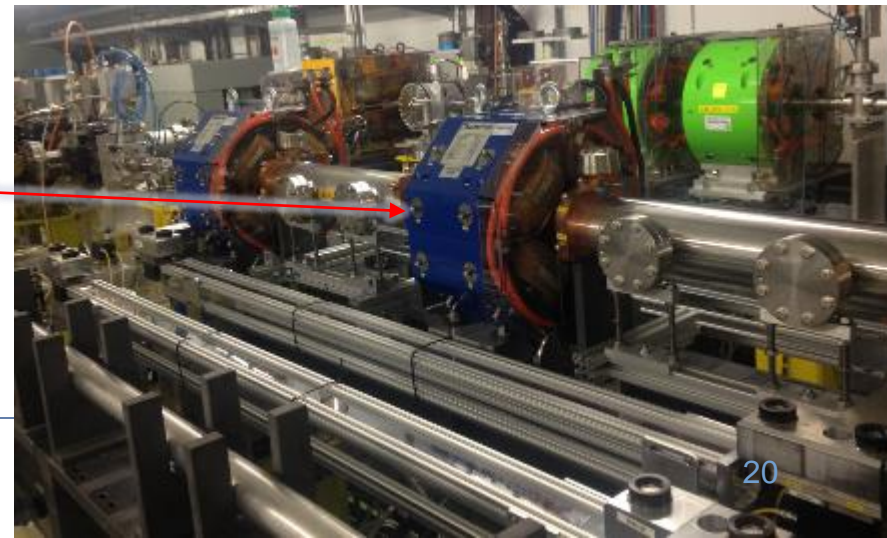
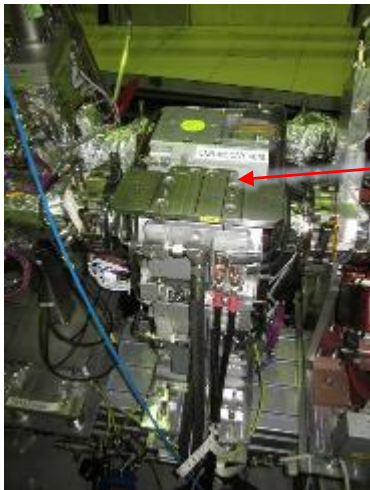

The fiducialisation

- It is the determination of the co-ordinates of fiducials w.r.t the reference axis (mechanical or magnetic) in a local coordinate system
 - 3 types of measurements according to the accuracy needed:
 - Mechanical measurements using a gauge (typically for warm magnets)
 - Laser tracker measurements when the requirements are of the order of 0.1 mm rms/Arm measurements
 - CMM measurements, for smaller components and requirements of the order of micrometers.



The fiducialisation

- The LHC dipoles

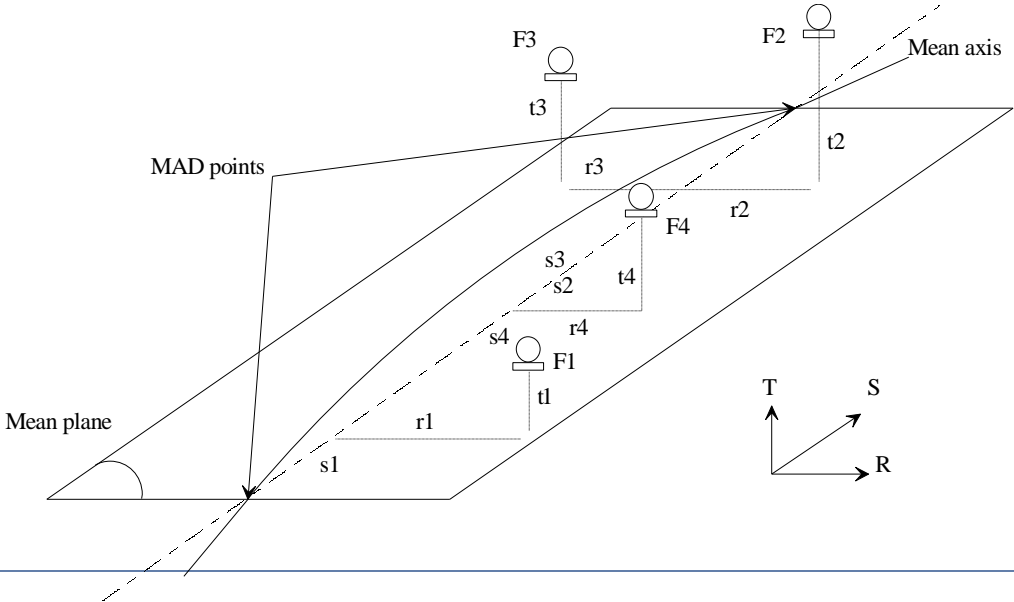
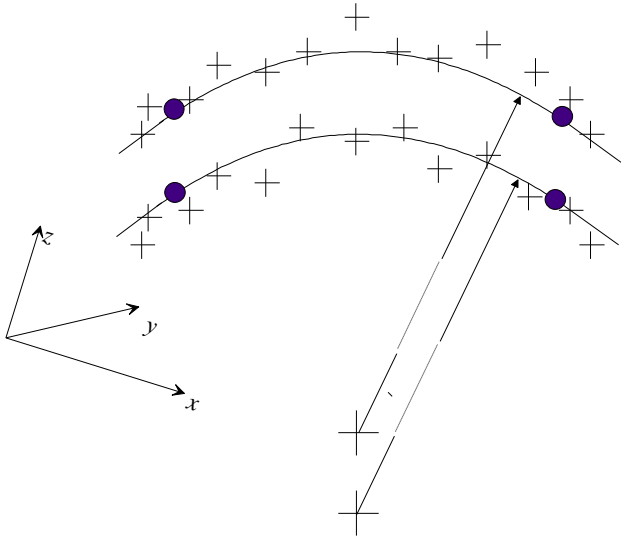

The fiducialisation

- The LHC dipoles

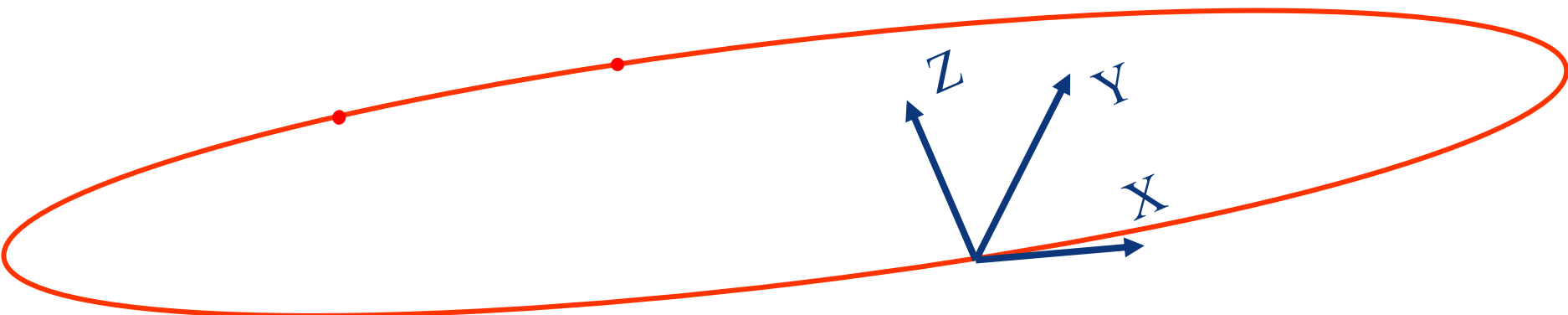
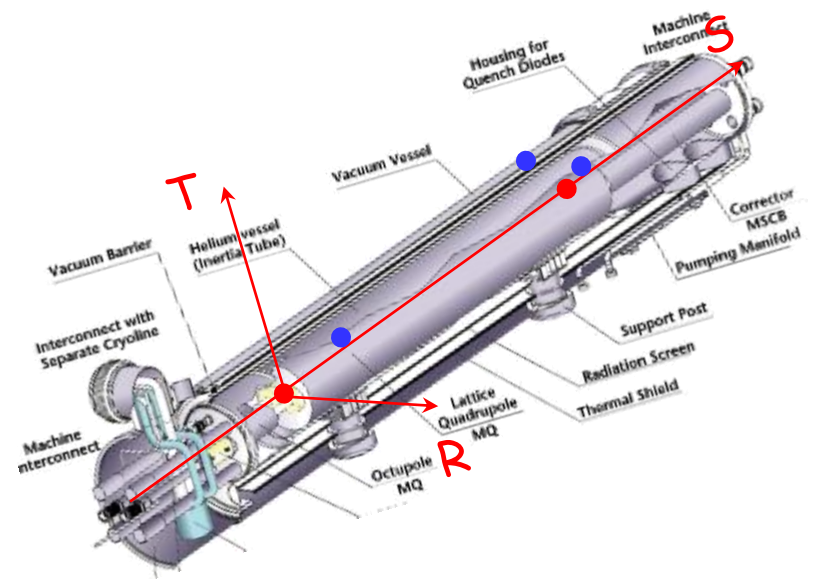

- From the MADx file and the fiducialisation data, we can calculate the coordinates of the fiducials in the GCS (XYZ and H)

The supporting/adjusting system

- They need to be supported by adequate supporting systems
- On 3 points preferably
- Always better if jacks aligned with fiducials

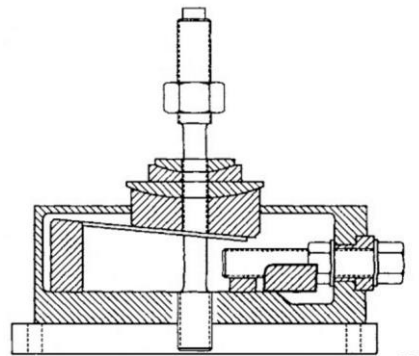
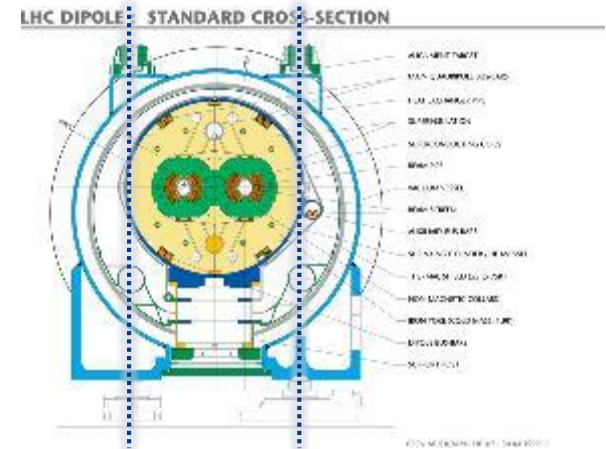

Wedge jack adjuster as used in APS.

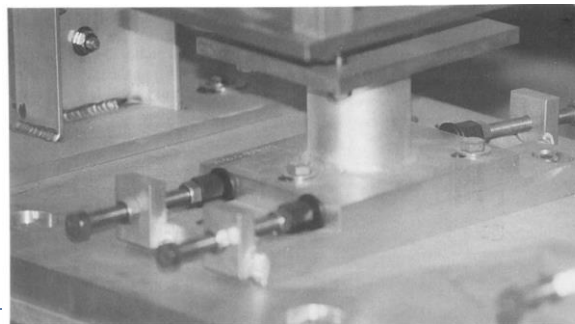
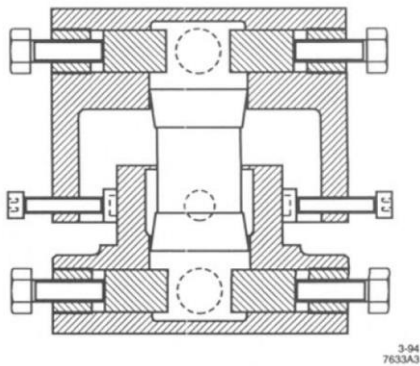

Push-push screw arrangement.

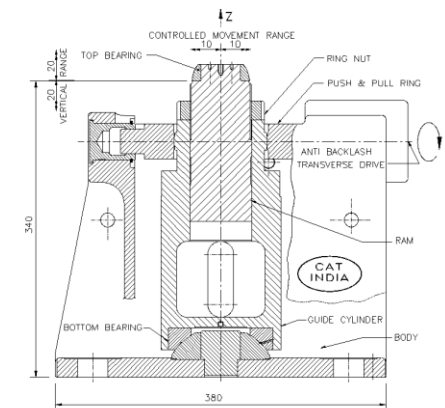

The supporting/adjusting system

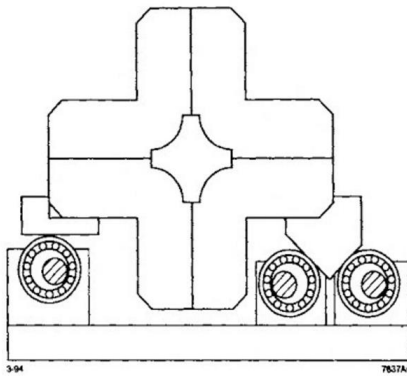
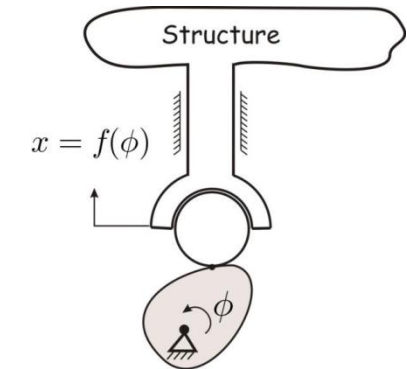

Magnet positioning mount with roller cams.

[PSI]

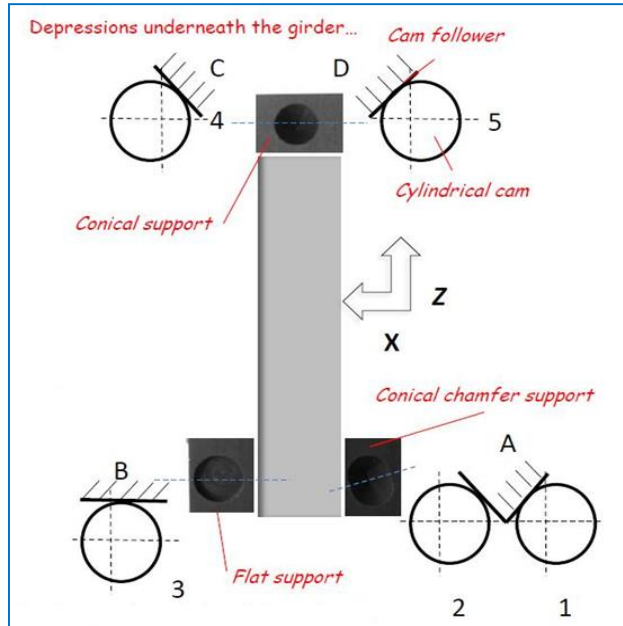

Eccentricity is given in the cam shaft

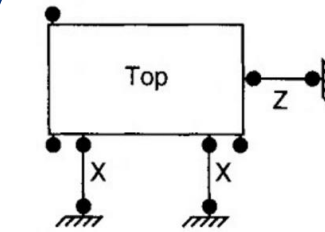
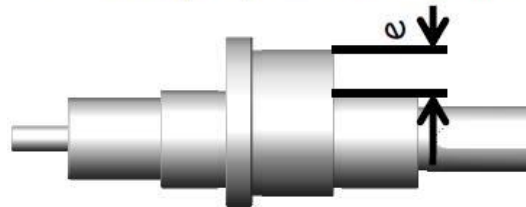

- 3 (Y) Vertical Struts
- 2 (X) Lateral Struts
- 1 (Z) Lateral Strut

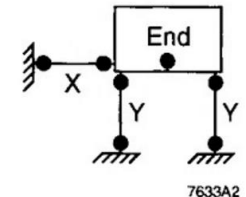
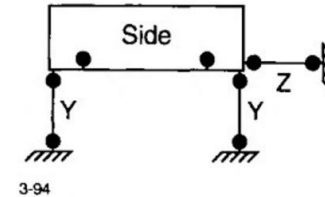

Kinematic suspension.

[ALS] Struts are length-adjustable rigid members with spherical joints at each end.



ALS 5-ton machine screw jack strut.

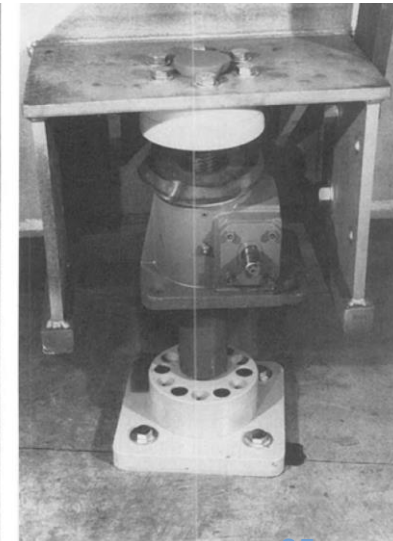

ALS 20-ton machine screw jack strut.

The supporting/adjusting system

- Motorized jacks (CERN LHC)

"Short" magnets : Q1, Q3

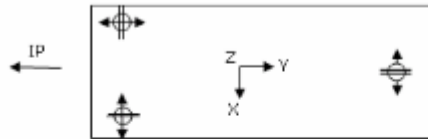

- Vertical adjustment
- ↔ Longitudinal adjustment
- ≡ No adjustment (free)
- ↕ Radial adjustment

"Long" magnets : Q2

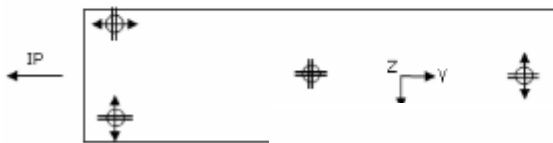

- Vertical adjustment
- ↔ Horizontal adjustment
- ≡ No adjustment (free)

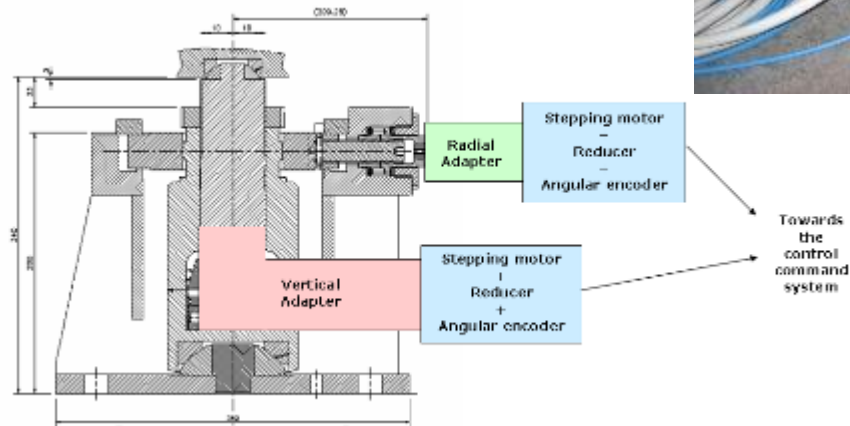

- Used successfully for realignment of some microns with beam in May 2016

How do we proceed ?

The initial alignment

- To ensure the absolute accuracy
- Realised w.r.t. the geodetic underground network
 - Roll and Vertical : Optical level
 - Horizontal : total station TDA5005, TS60
- Accuracy 0.2 mm in Z/H, 0.3 mm in XY

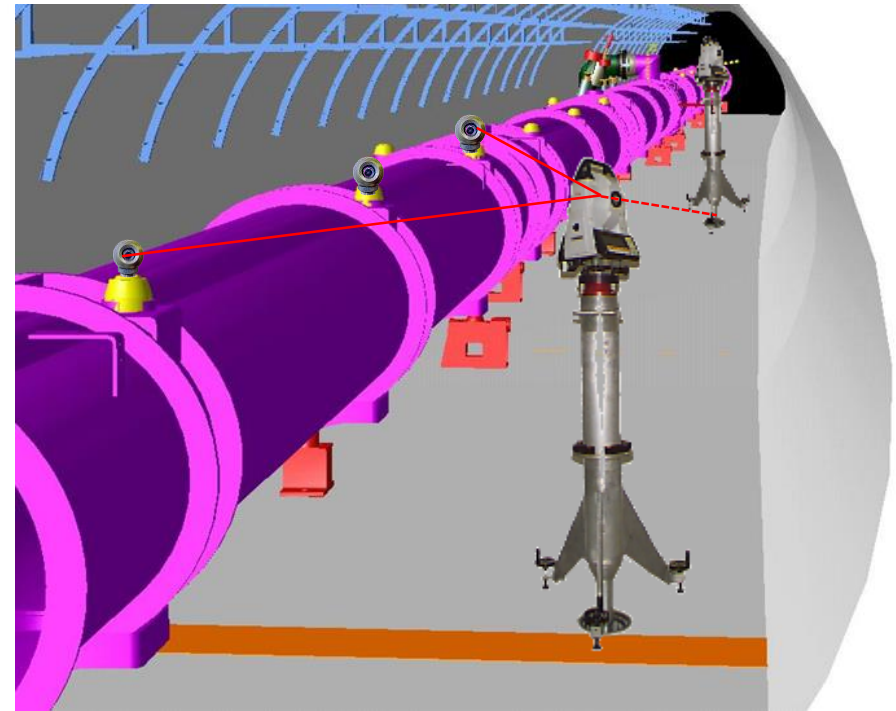
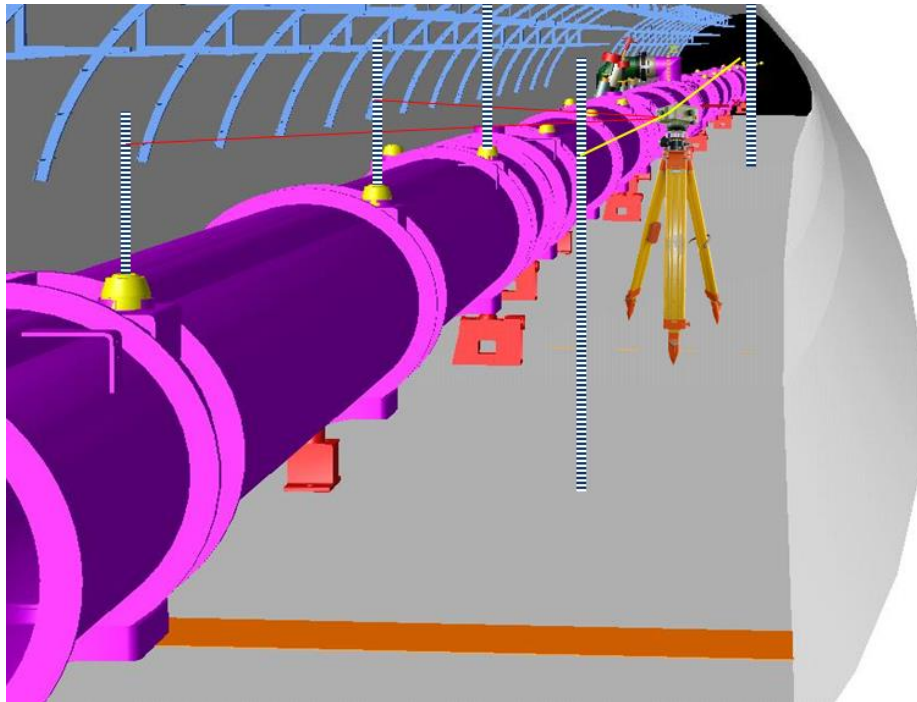
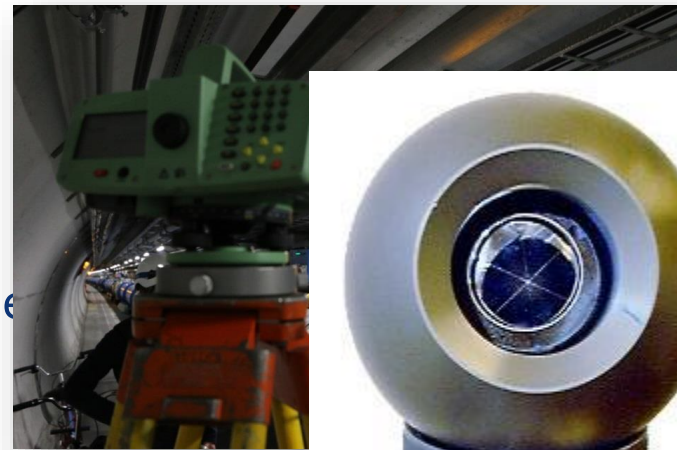

The smoothing operation

- To ensure the relative accuracy
 - Not using network but only the fiducials of magnets
 - Roll and Vertical : Optical level
 - Horizontal : offsets w.r.t. a stretched wire
 - No longitudinal measurement is done

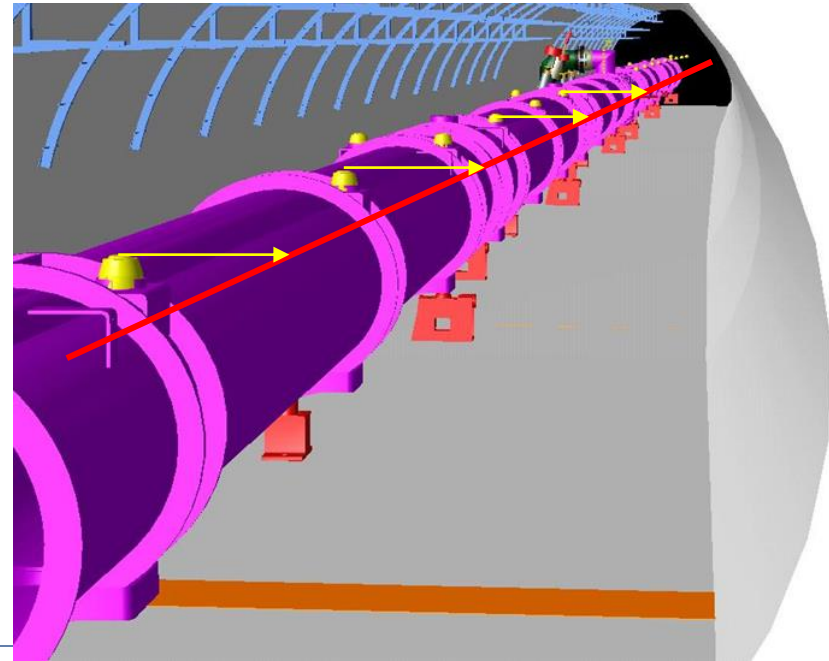
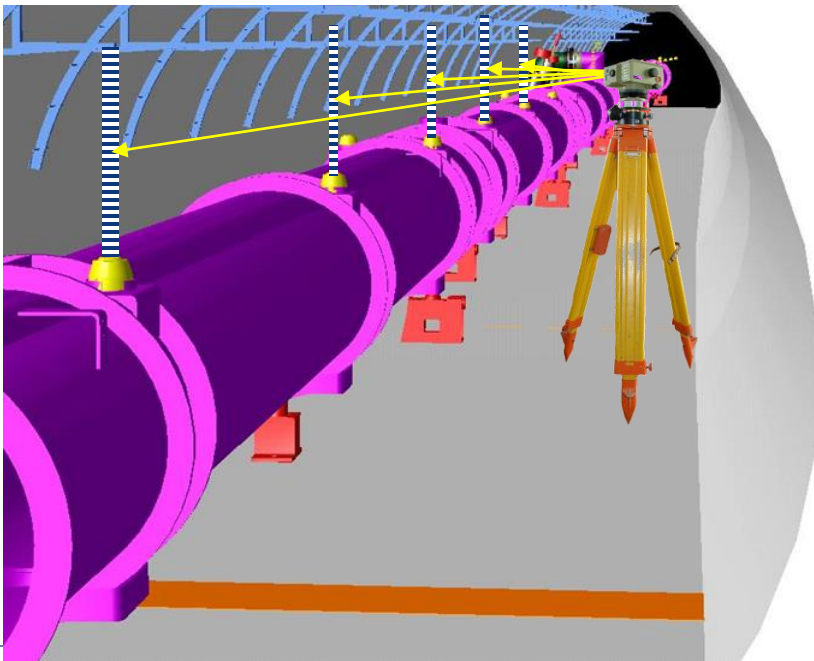

Wire Offset measurement

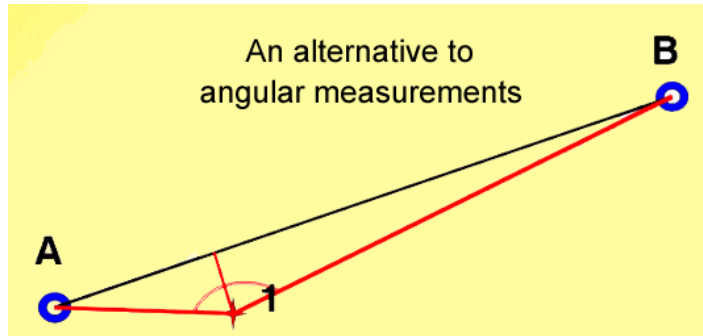

- This technique is an alternative to small angle measurements
- Measurement of a small distance w.r.t a wire (nylon, kevlar, vectran, etc)
 - Simple, cheap, quick, accurate (< 0.1 mm), no subject to refraction errors
 - distance limitations (1.40m), orthogonality, air currents (wind), systematic errors

Wire Offset measurements

- Application to a circular collider
 - Wire of 100m, redundancy of measurement of 2 or 3 components

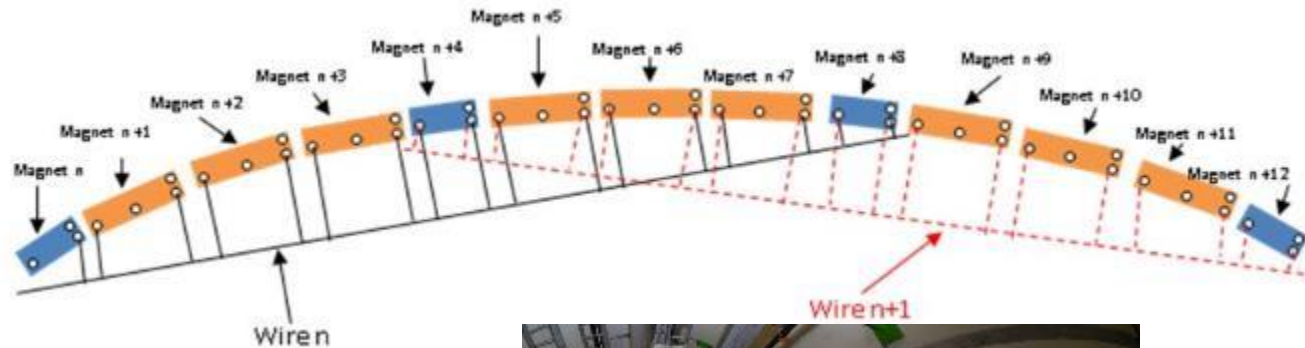

- 500m/day
- Residuals of 40 microns



LHC 7-8 lissage à froid - écartométrie- distribution des résidus après compensation

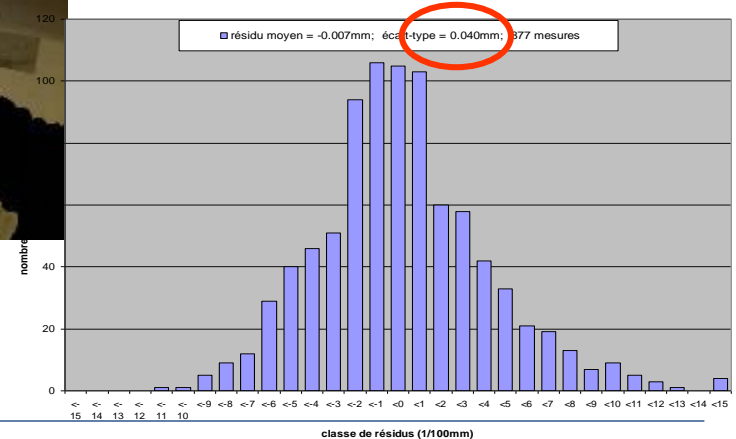

«Planing»

- The goal is NOT to realign all the magnet at their nominal position
 - But to realign the ones which are far away from a SMOOTH curve

LHC 7-8 lissage à froid écartométrie

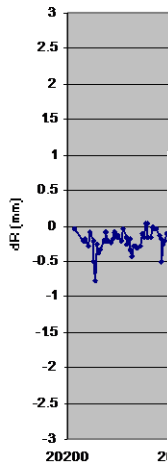

12691-rabot.rab (Plani)

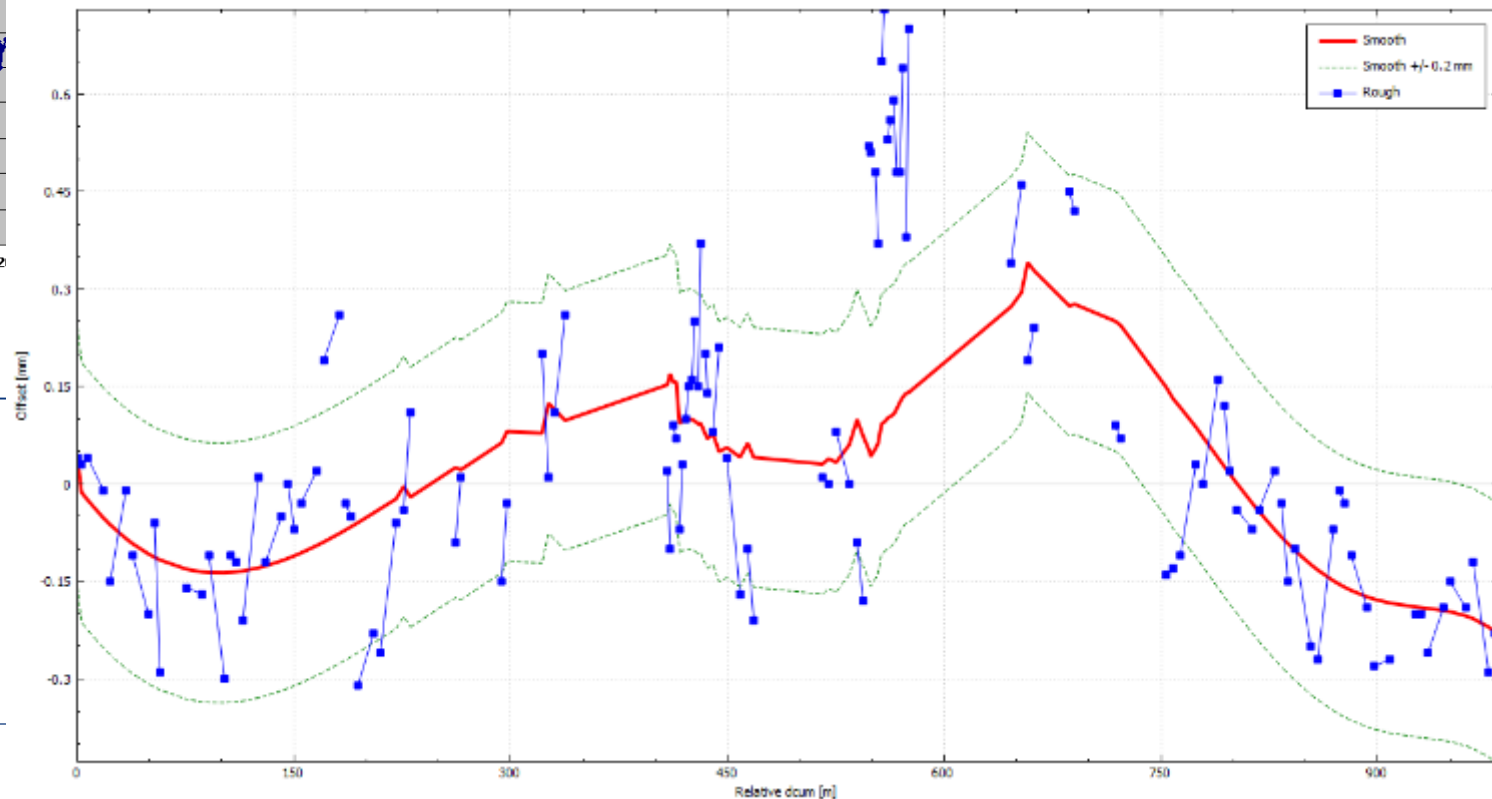

- ... a bit like the carpenter gets rid of a small piece from a wooden beam
- The PLANE software has been



Remote measurements

- Determine remotely (because of high radiation dose) the position of collimators w.r.t the two adjacent quadrupoles: ± 0.2 mm
 - Photogrammetry
 - Offset to a stretched wire

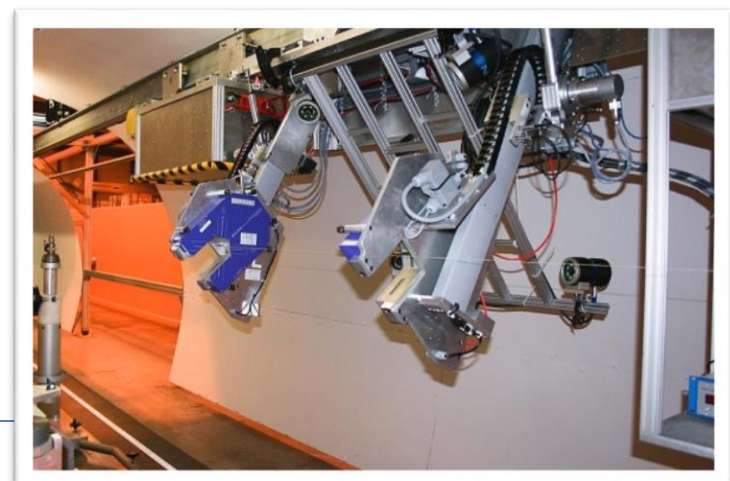
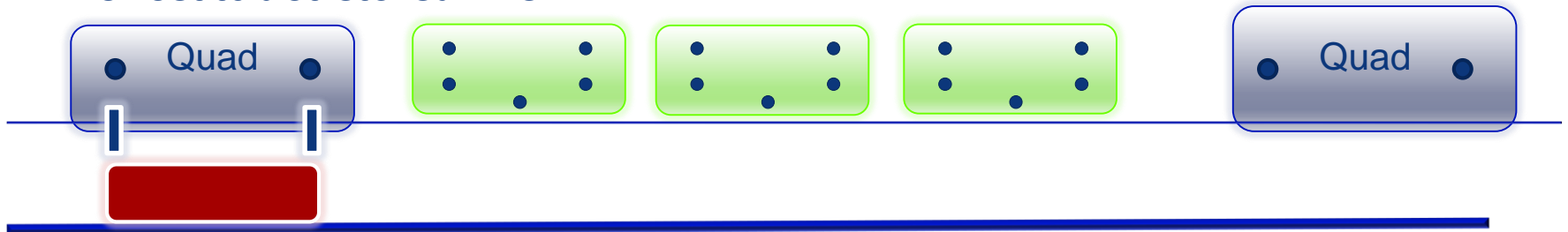

Permanent monitoring sensors

Hydrostatic Levelling System

- Capacitive
- Ultrasonic
- Floating sensor
- several microns of accuracy

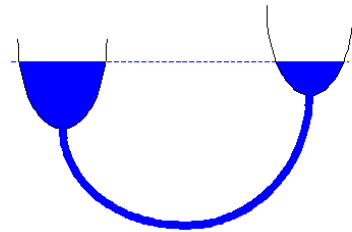

Technologie capacitive

Principe:

L'électrode au capteur et l'objet mesuré forment un condensateur dont on mesure soit la capacité électrique, soit l'inverse de la capacité.

$$C = \frac{\epsilon_0 \cdot \epsilon \cdot S}{d}$$

avec: C = capacité électrique
 ϵ_0 = permittivité du vide
 ϵ = permittivité du milieu
 S = surface électrode mesurée
 d = distance entre électrodes

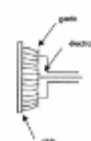

Basés sur la technologie capacitive FOGALE Nanotech, ils ont été développés par l'ESRF en 1987 pour réaliser l'alignement vertical permanent de l'anneau de stockage. Les capteurs ont été ensuite optimisés au fur et à mesure de leur utilisation au CERN et KEK



Technologie ultra-son

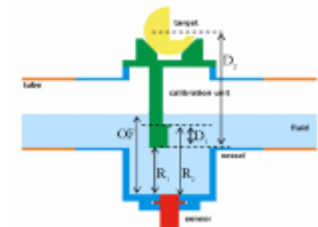

Ces capteurs ont été développés pour l'alignement de TESLA à DESY

Nouveau concept de calibration « in situ » éliminant les dérives des capteurs.

Développement d'un pot spécial dans lequel 2 références D1 et D2 sont connues et restent constantes dans le temps. La référence est faite en invar.

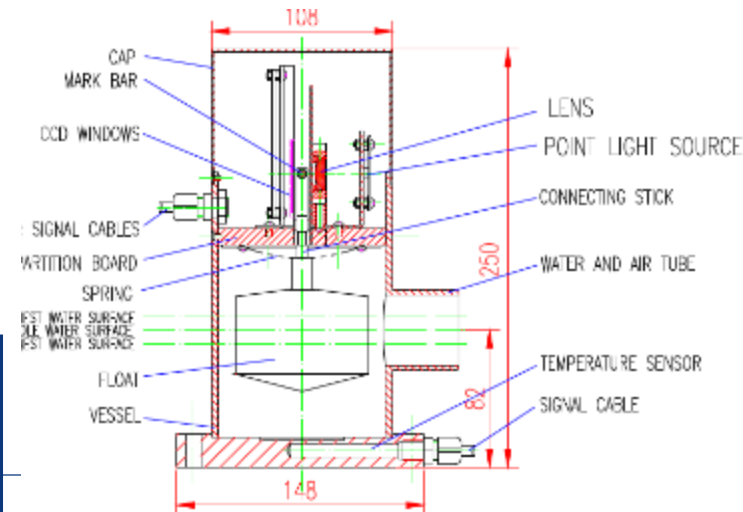
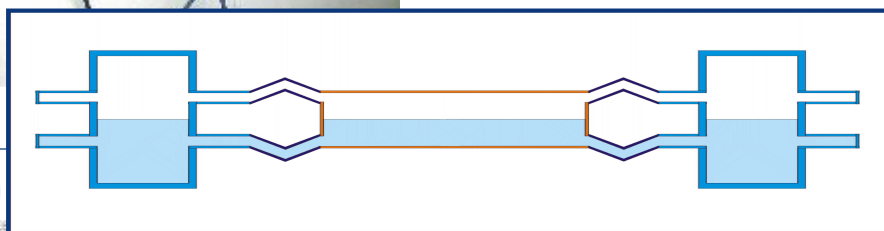
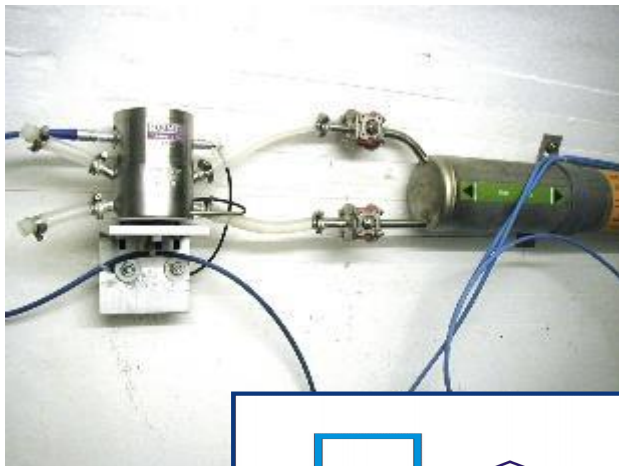

Applications

- The bed plates of ATLAS

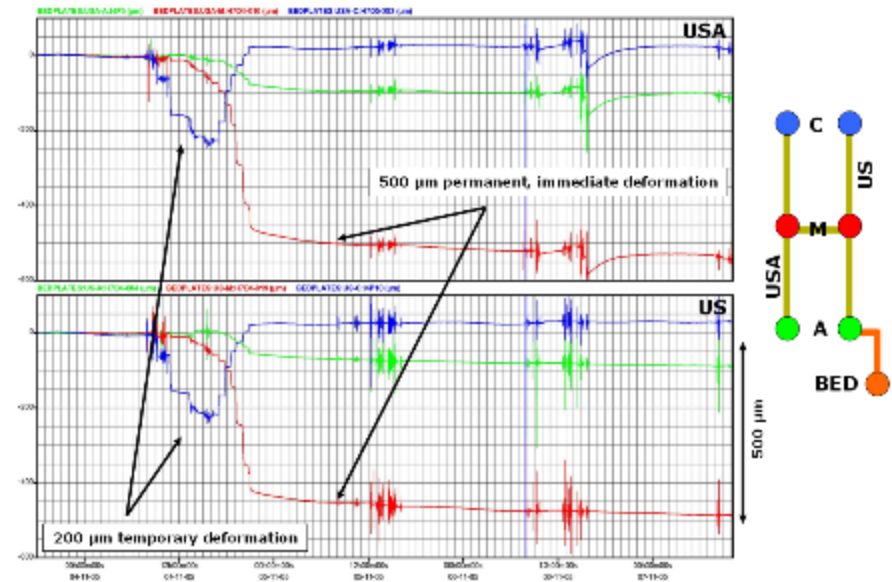
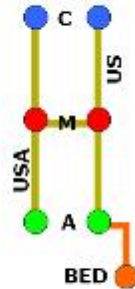
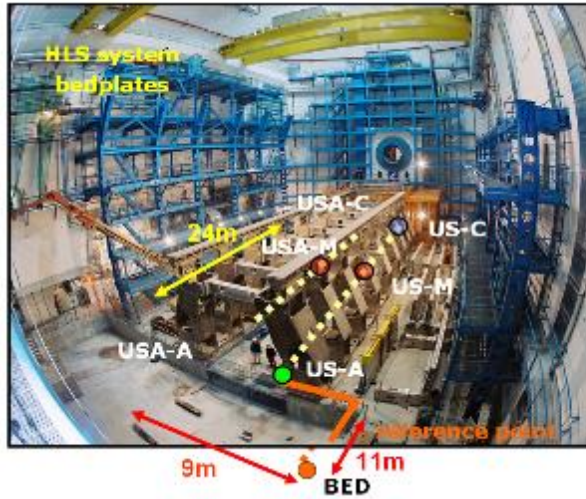

Applications

- The Inner Triplets (Low Beta quads) of the LHC
 - 0.1 mm within a triplet- several microns during a run permanently
 - 0.1-0.2mm from one side to the other side of the Experiment

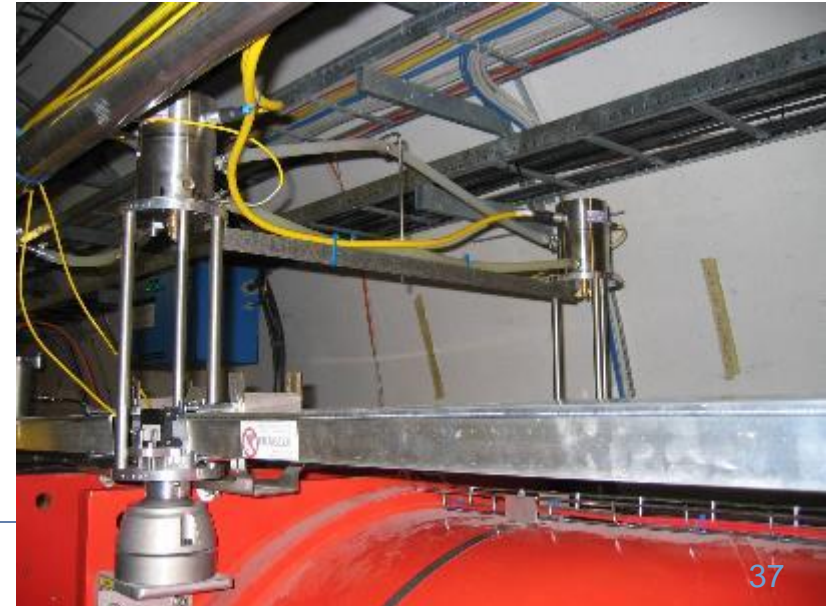
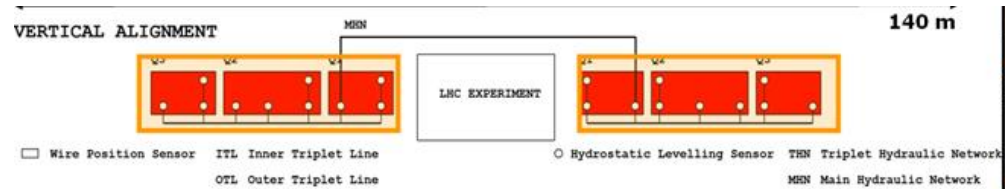
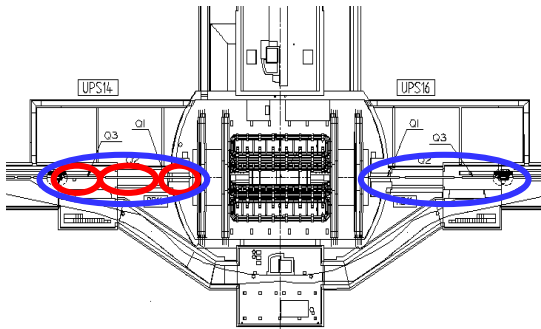

Wire Positioning Sensor

- Capacitive cWPS
- resolution: 0.2 mm
- range 10 x 10 mm
- In the horizontal plane : straight line
- In the vertical the wire is a catenary

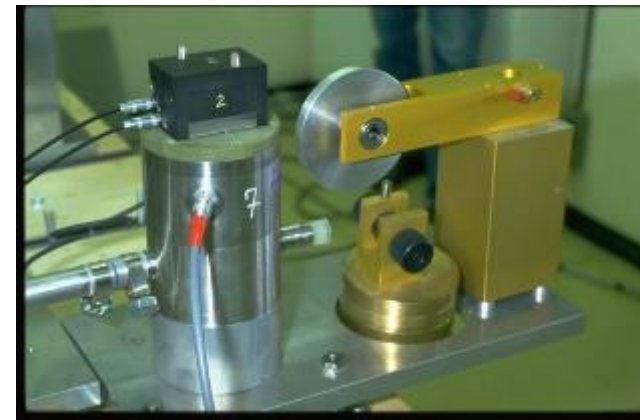
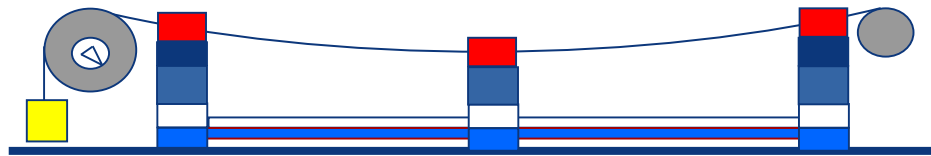
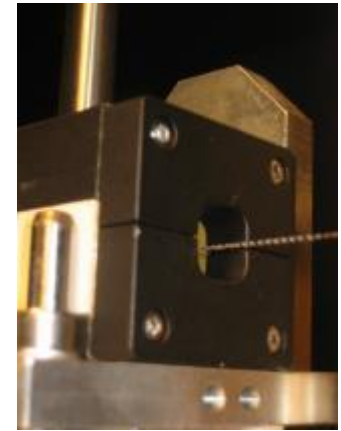
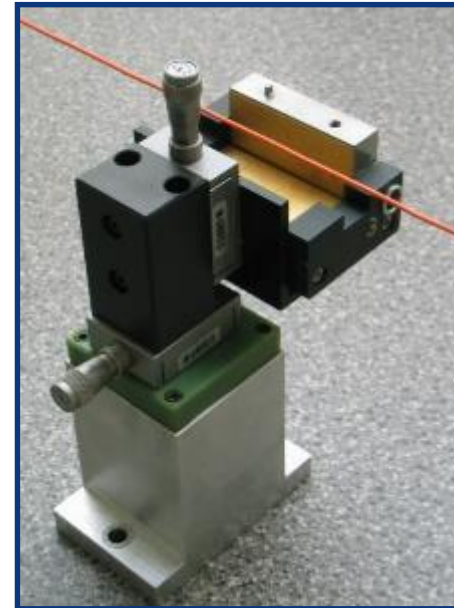

Applications

- The Inner Triplets (Low Beta quads) of the LHC

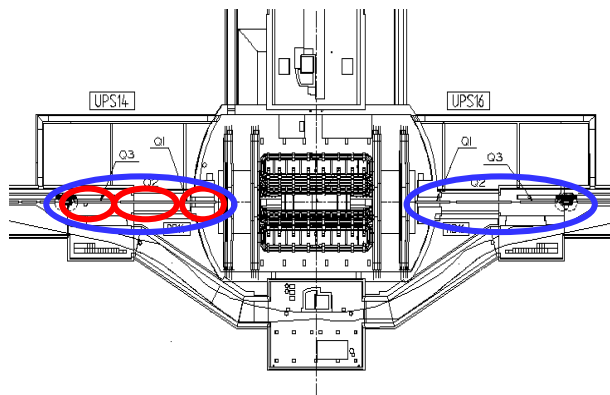

RADIAL ALIGNMENT



The Optical WPS

- oWPS
 - W.r.t. a stretched wire
 - Two cameras are measuring the position of the wire
 - Resolution of a few of microns
 - NOT rad hard
 - Quite cheap

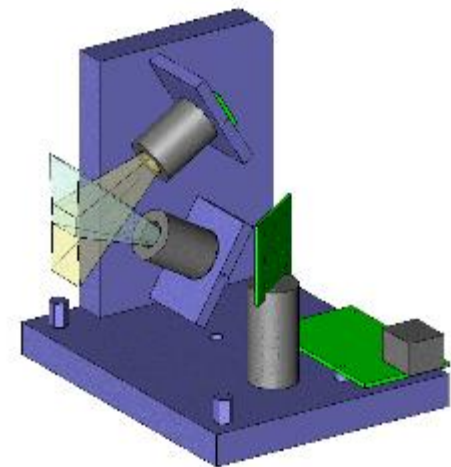

Photogrammetry of a wire

- The goal is to measure position of fiducials w.r.t a stretched wire using a camera
- Test bench
 - Based on ceramic spheres
 - Metrology with 2 microns precision
 - Validation shows an accuracy of 5-10 microns at 1.5 m
- Test done on a LHC cryostat
 - Promising
 - Still to do
 - Automatisations of wire detection in a picture

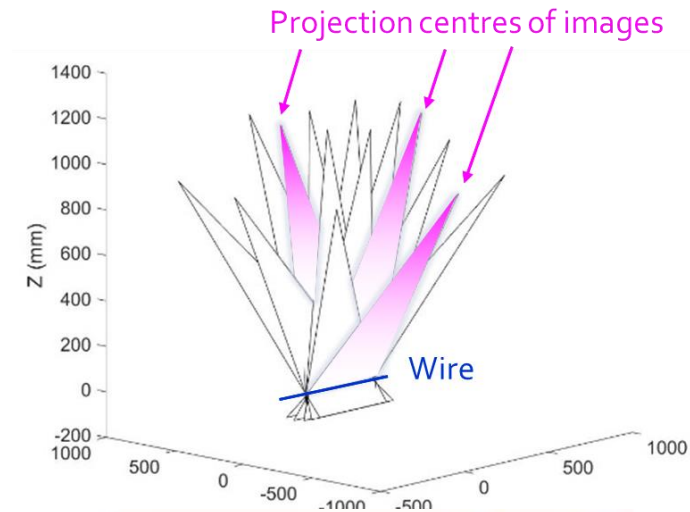
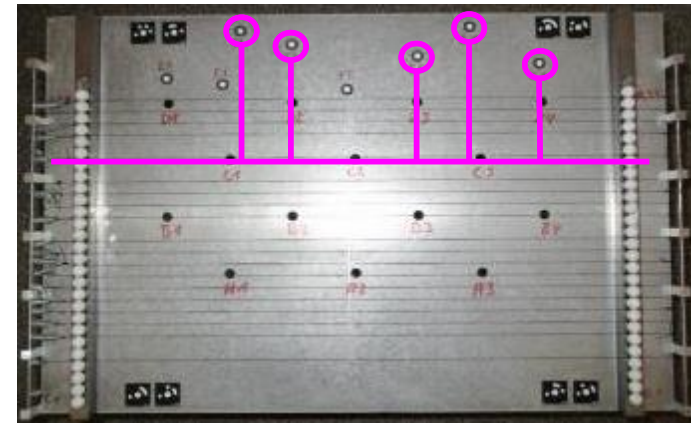

Wire Positioning Monitor

- 4 electrodes generates induced voltage when an RF signal passes through the center
- Position of the wire is deduced from voltage of opposite pair of strips
- Use at SLAC for the monitoring XY of the quads and the roll, pitch and yaw of the undulators (Alignment Diagnostic System)
- Accelerator Driven Sub critical system (IHEP, Beijing) for monitoring of movement of cold mass during warm-up and cool-down

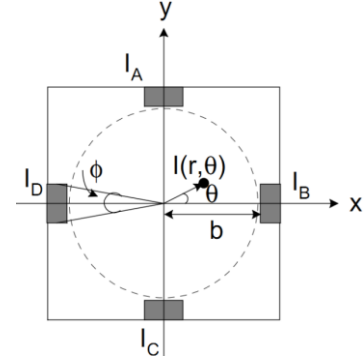

Wire Position Monitor System (WPM)

- **Resolution** < 100 nm in X & Y Direction
- **Instrument Drift** < 100 nm per day
- **Moving Range** ± 1.5 mm in X & Y Direction
- **Accuracy** 0.1 % of full Scale
- **Availability** Permanent, no Interrupts

X and Y can be measured

Owner: Franz Peters

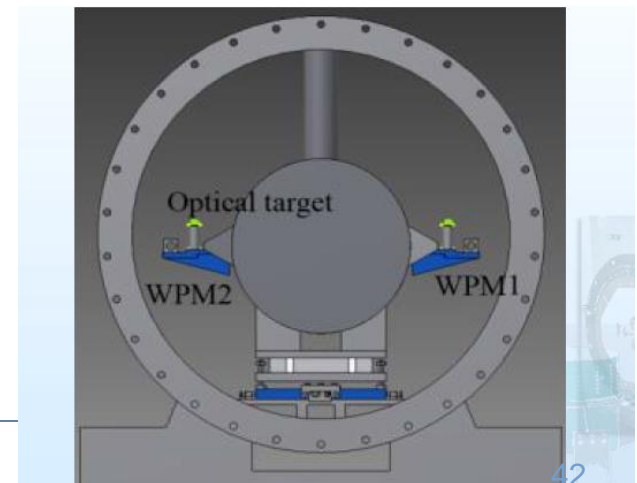
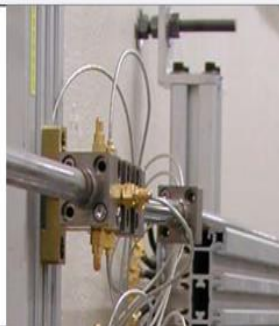

Schematic layout of WPMs and optical target

Brandeis Camera Angle Monitor

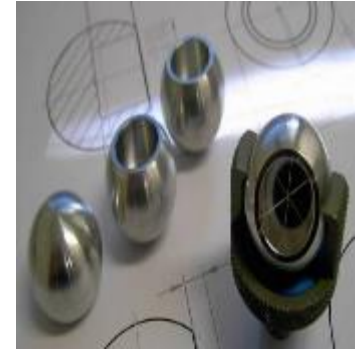
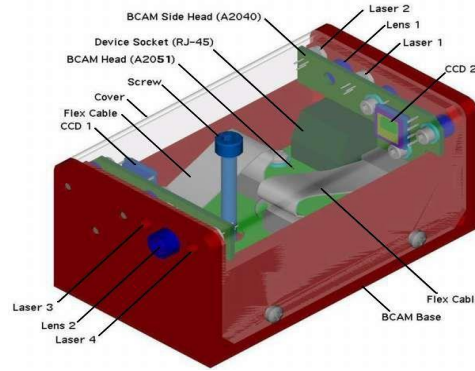
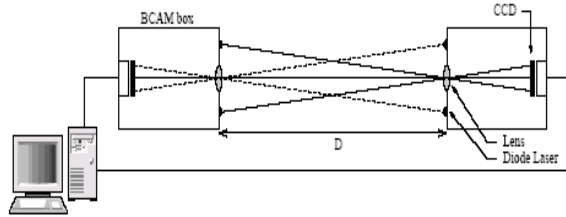

- For LHC Experiments

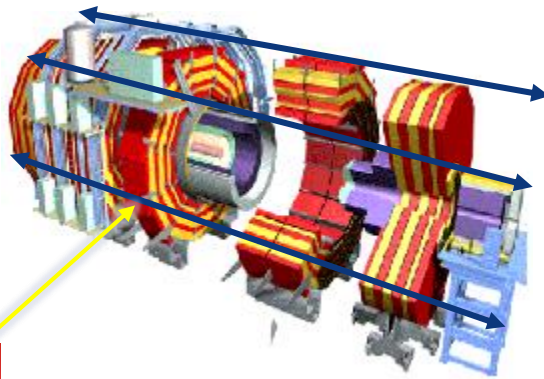

- For HIE-Isolde Cryo-modules monitoring

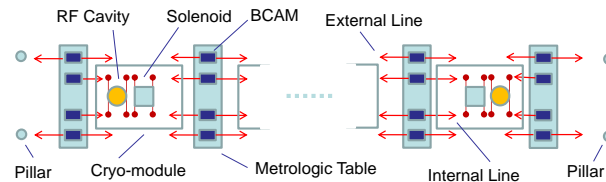
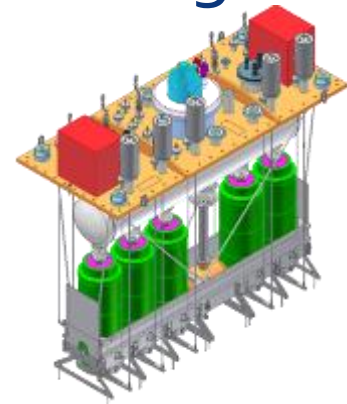
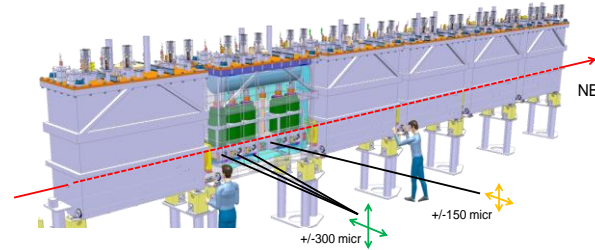

→ BCAM observations - Overlapping on external lines

Observing diffraction pattern of Fresnel zones plates

- LC of SLAC

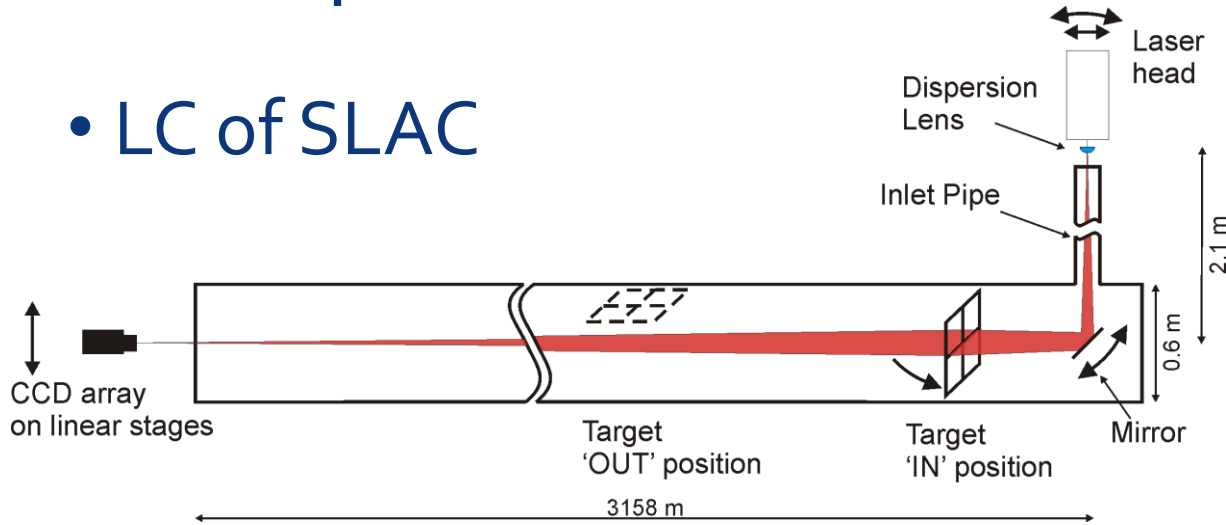

Advantages	Drawbacks
Large number of targets (~300)	Repositioning of targets
Rad-hard	Non compact targets

Observing diffraction pattern of an iris

- Spring 8 (SCSS)

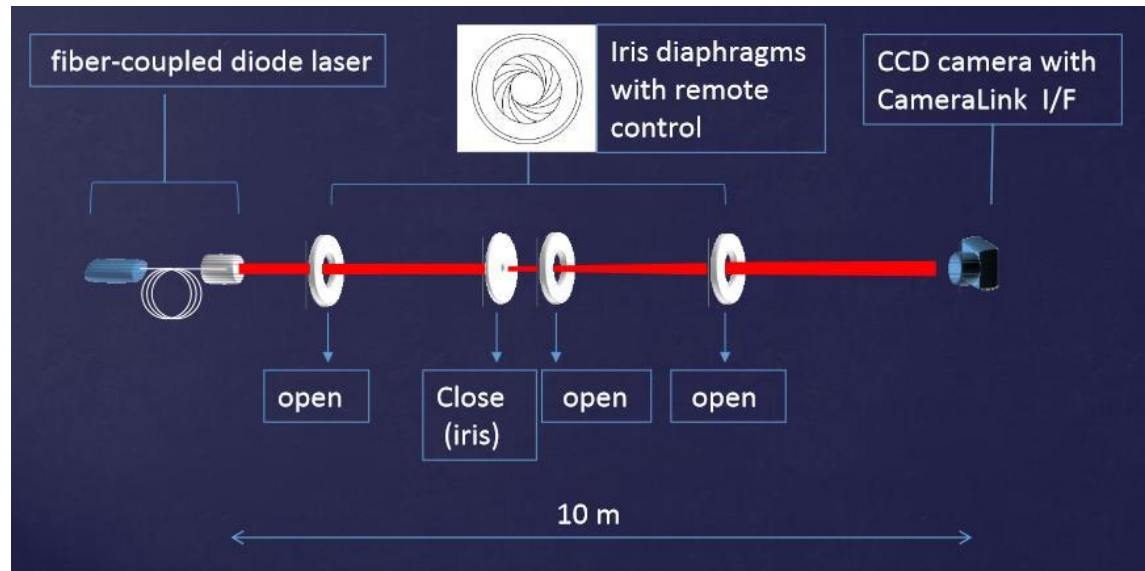

Advantages	Drawbacks
Static targets Multiple targets system	Measurement uncertainty depends on longitudinal position

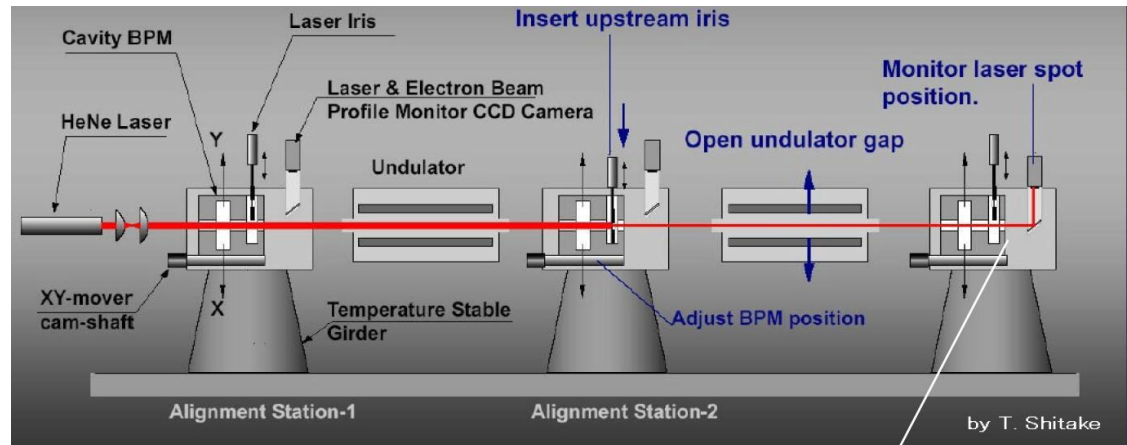

Observing diffraction pattern of spheres

- Poisson system (DESY in the Xfel)

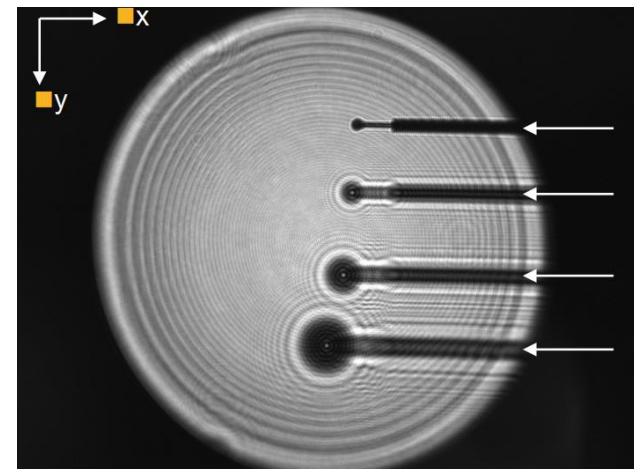
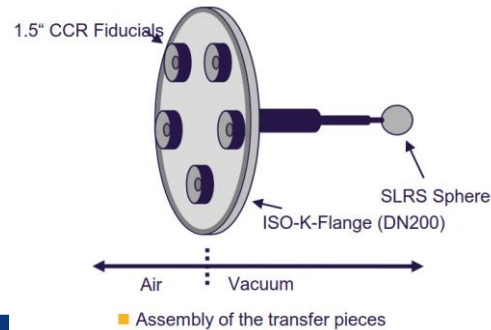
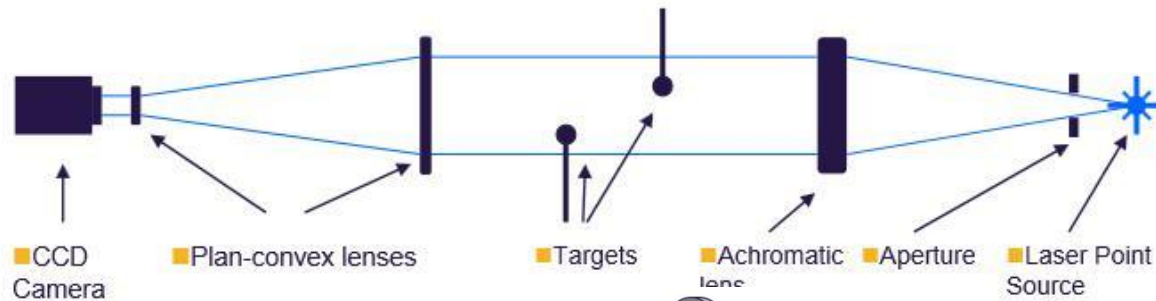

Advantages	Drawbacks
Static targets	Limited number of targets (~16)
	Measurement uncertainty depends on longitudinal position

Observing diffraction pattern of a plate

- NIKHEF

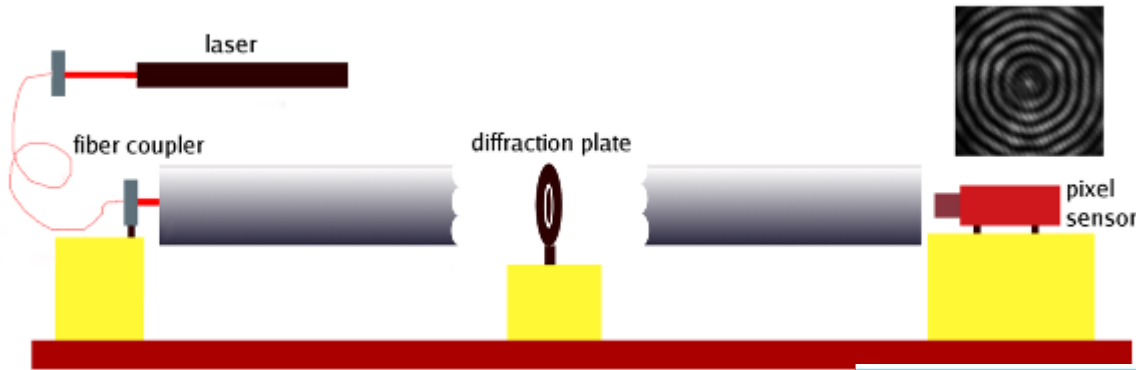

Experimental setup: Long range Rasdif

Advantages	Drawbacks
Static plate	Only 1 target

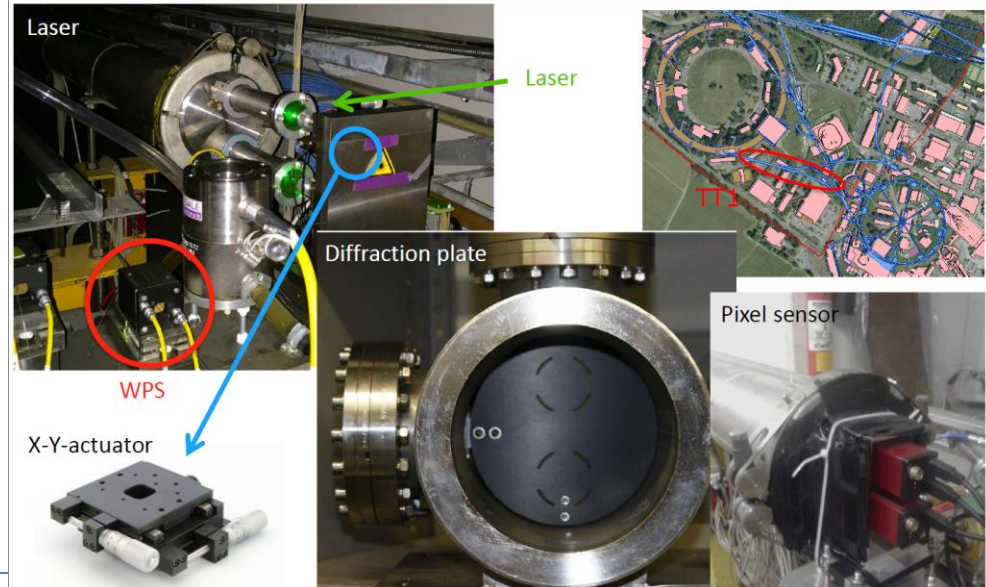

Laser spot with open / close QPD's (KEKB)

- KEKB linac of 500m

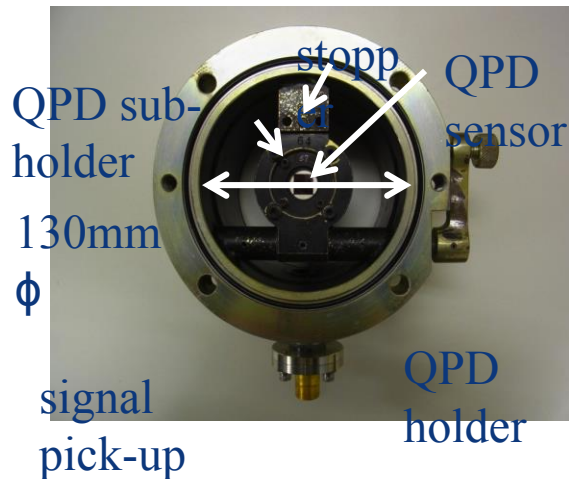

QPD: quadrant photo-detectors

Advantages	Drawbacks
Large number of photo-detectors	Uncertainty due to open/close photo-detectors

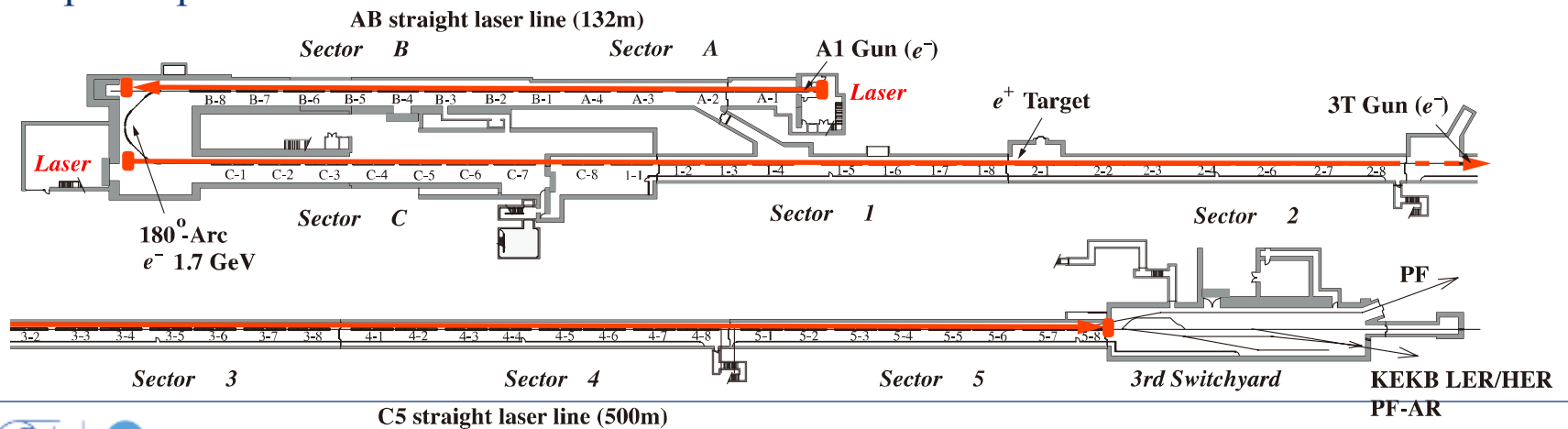

Laser Alignment Multi-Based Design Approach

- CERN
- for CLIC study

Advantages	Drawbacks
Multiple points	Uncertainty due to open/close shutters Stability of the laser Size of the laser spot

LAMBDA project: principle

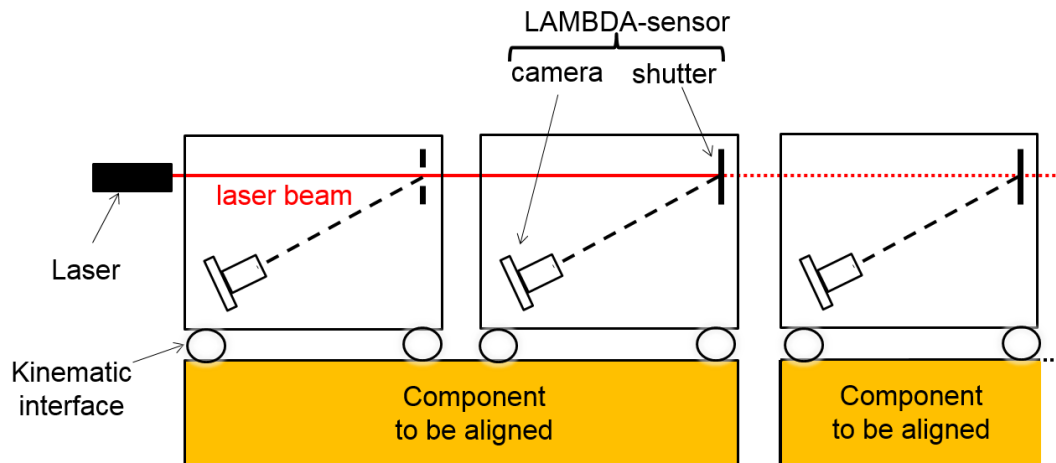

Future colliders requirements

Future Colliders requirements

- ILC

Area	(km)	Nb of components	Nb of beam	Error of misalignment on the fiducials (1σ)
e- source	2.3	30 cavities supports 150 components 17 correctors	1	0.1 mm rms over 150 m
e+ source	3.3	31 cavities supports 540 components 184 correctors	1	0.1 mm rms over 150 m
DR	3.3	2898 supports 1154 correctors	2	0.1 mm rms over 150 m
RTML	1.7	130 cavities supports 2377 components 2434 correctors	1	0.1 mm rms over 150 m
Main linac	23.9	1701 cryo-modules Correctors inside cryo-modules	1	0.2 mm rms over 600 m
BDS	6.5	460 components 120 correctors	1	0.02 mm over 200 m

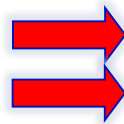

- CLIC

- Pre-alignment
- All errors included
 - (fiducialisation)

Area	Error of misalignment on the fiducials (1σ)
e- source	0.1 mm
e+ source	0.1 mm
DR	0.1 mm
RTML	0.1 mm
Main linac	14 μ m over 200 m (RF structures) 17 μ m over 200 m (MB quad)
BDS	10 μ m over 500 m (RF structures)



CLIC

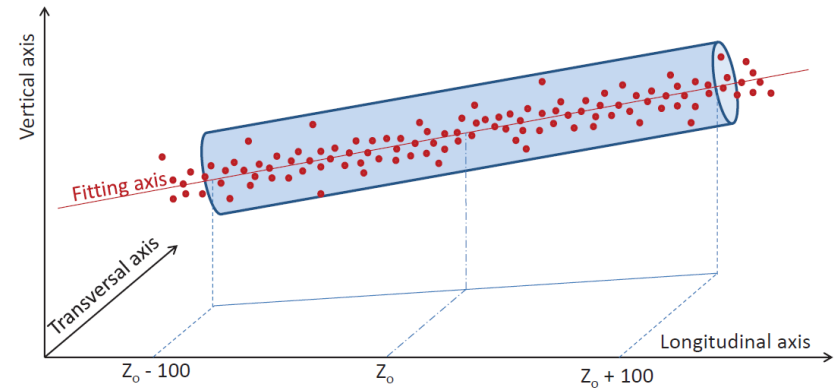

- The radius of the cylinder describes well the **total** error budget allocated to the positioning of the major accelerator components.
 - Along the MB, it is equal to $14 \mu\text{m}$ r.m.s. for the RF structures, $14 \mu\text{m}$ for the BPM, $17 \mu\text{m}$ for the MB quadrupole.
 - Along the DB, it is equal to $20 \mu\text{m}$ for the DB quadrupole, $100 \mu\text{m}$ for the PETS.

CLIC Alignment strategy

- Absolute alignment using overlapping reference lines



- Relative alignment of the elements

- Components are pre-aligned on a common support



- Sensors & actuators are associated to each support / articulation point of girder

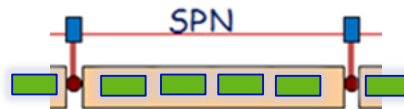

CLIC Alignment strategy

- If you combine long & short systems

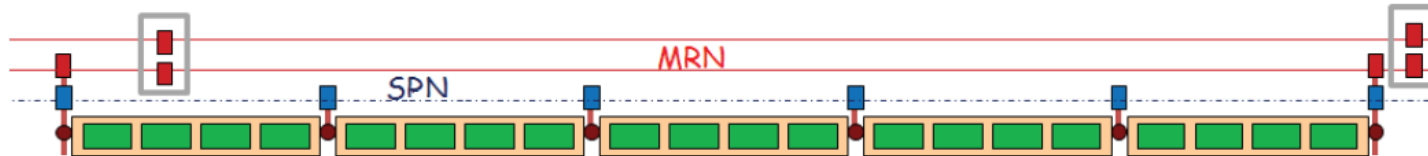

- Adjustment configuration

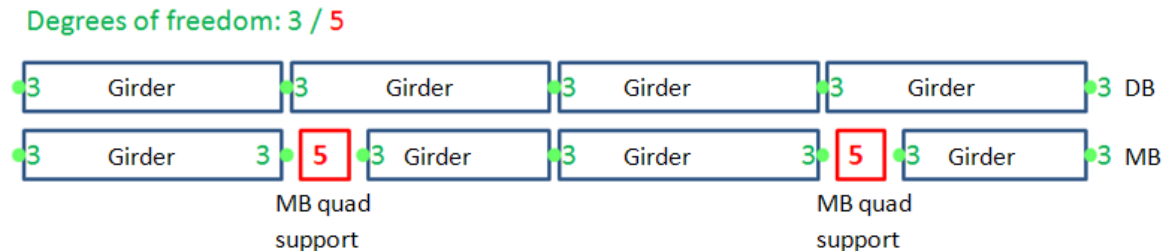

- After optimization, in case of a stretched wire & WPS used for long range & short range systems

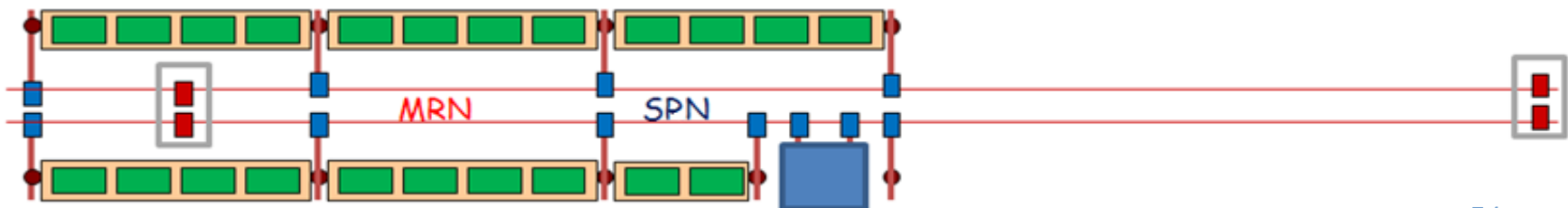

Validation of the strategy

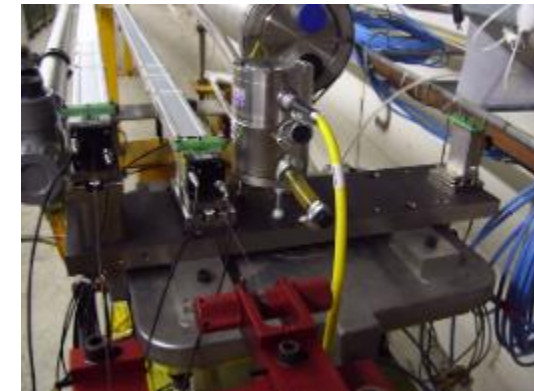
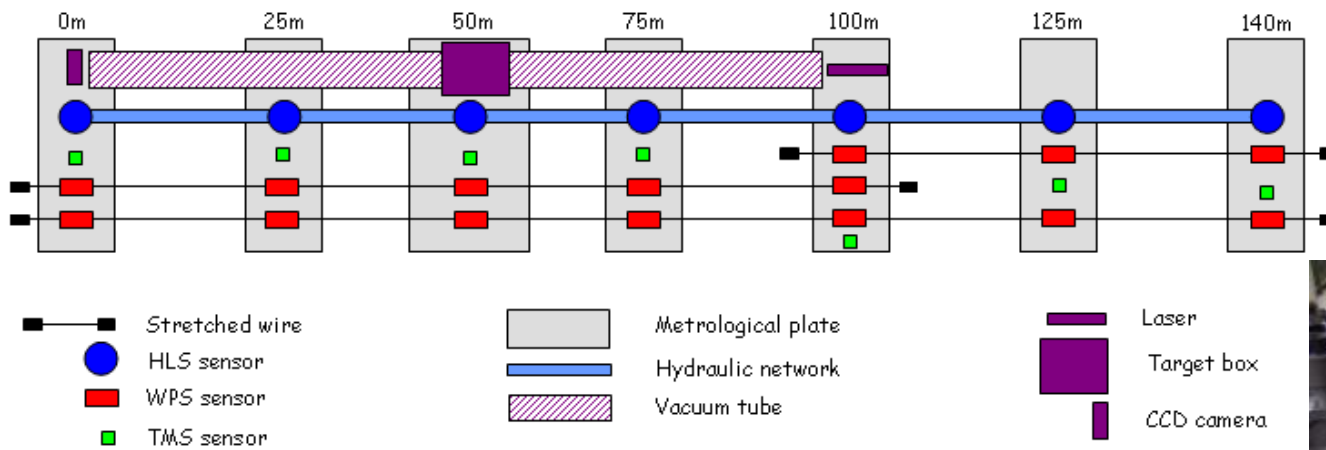

- TT1 facility at CERN
 - 140m, 7 metrological plates, HLS and WPS
- After least squares adjustment:
 - Radial residuals on sensors readings $< 6 \mu\text{m}$ on the
 - Accuracy of radial translation: $\pm 9 \mu\text{m}$ r.m.s.
 - Vertical residuals on sensors readings $< 8 \mu\text{m}$
 - Accuracy of the vertical translation: $\pm 9 \mu\text{m}$
 - Continuous modelling of the wire catenary using sensors

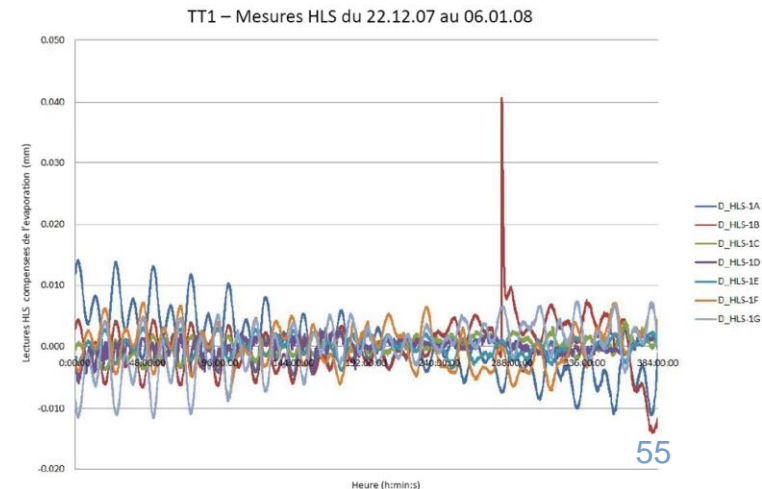

CLIC R&D

- For fiducialisation
 - A high accuracy & touchless sensor on the CMM measuring head (HEXAGON)
 - Microtriangulation
 - Angles and automatised of measurements (ETHZ)
 - FSI (Frequency Scanner Interferometry)
 - Only distance measurements, absolute distance meas.
 - Developed by Oxford, produced by Etalon AG
 - Uncertainty ($0.5\mu\text{m}$ per metre)
 - Several simultaneous measurements (up to 100)
 - Measure distances up to 20m
 - Laser beam can be interrupted

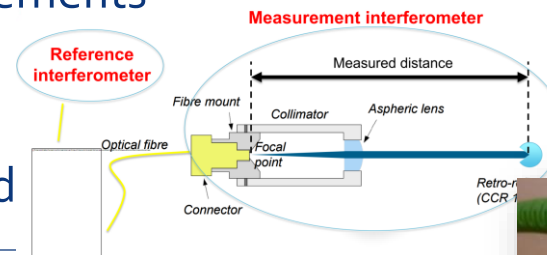
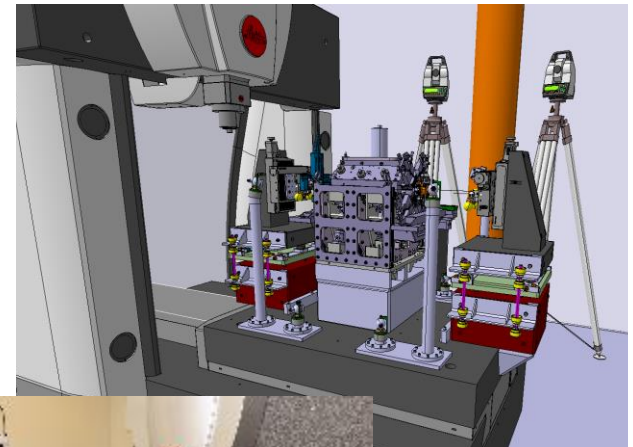

FCC

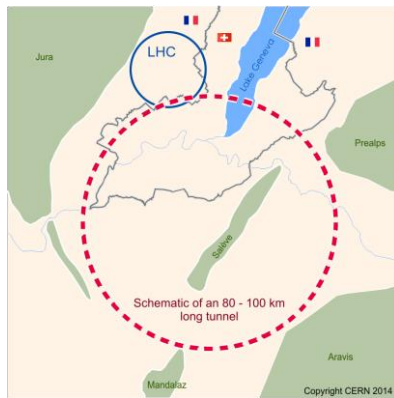

options	Error of misalignment on the quad magnetic axis(1σ)
hh	0.5 mm (similar to LHC)
ee	0.1 mm (almost CLIC !)
he - eh - HE	0.2 mm

- A new geoid has to be defined for a 30km x 30 km area
 - French and swiss data are not given with the same accuracy
- The size of the collider is very challenging
 - Distance between shafts can be up to 10km
 - Depth of shafts up to 400m
 - For hh : the cell is double the size of LHC (~224m)
 - Collimators area will be inaccessible after a few years of run : robotics, survey train to be studied
 - For ee : the CLIC solution will be proposed
 - Studies will start this year to reduce the cost
 - The Qo is inside the detector : it is a major pb for alignment !

←← Improve accuracy

Conclusions

The Micron World, in which steel acts like butter and in which temperature excursions are like Gulliver's Travels, has been tamed and industrialized on the laboratory scale. I do not believe the problems that we are going to encounter in the design of future linear colliders on a kilometer scale will turn out to be *fundamental*. Rather, the challenge will be to be innovative enough to find sound engineering solutions that we can *afford*. Further, we should involve the alignment community in all aspects of the design decision making process at the earliest moment.

ALIGNMENT AND VIBRATION ISSUES IN TeV LINEAR COLLIDER DESIGN

G. E. FISCHER

Stanford Linear Accelerator Center

Stanford University, Stanford, CA



ENGINEERING
DEPARTMENT