

# Switched Mode Converters (1 Quadrant)

Philippe Barrade

Laboratoire d'Electronique Industrielle, LEI

STI – ISE

Ecole Polytechnique Fédérale de Lausanne, EPFL

Ch-1015 Lausanne

Tél: +41 21 693 2651

Fax: +41 21 693 2600

[Philippe.barrade@epfl.ch](mailto:Philippe.barrade@epfl.ch)

## Summary

- Introduction
  - DC supplies: principle
  - Linear or Switched Mode Converters
  - Switched Mode Converters: main challenges
- DC/DC direct converters
  - Buck, boost, buck-boost converters
  - Multi channels converters
- Transformers for DC/DC converters
  - Principle, Model
  - Sizing of a transformer: weight, power and frequency
- DC/DC converters with transformers
  - Forward
  - Flyback
  - DC/AC/DC converters

## Introduction

- DC supplies: principle
  - Switched mode converters are DC/DC converters
  - They are generally supplied from an AC network, via:
    - A transformer
      - ⇒ For a galvanic insulation
      - ⇒ For voltage level adaptation
    - A rectifier
      - ⇒ In order to obtain a DC voltage source
  - Switched mode converters are used to generate controlled and adjustable DC voltage levels

# Introduction

- DC supplies: principle
  - Typical (and possible) architecture

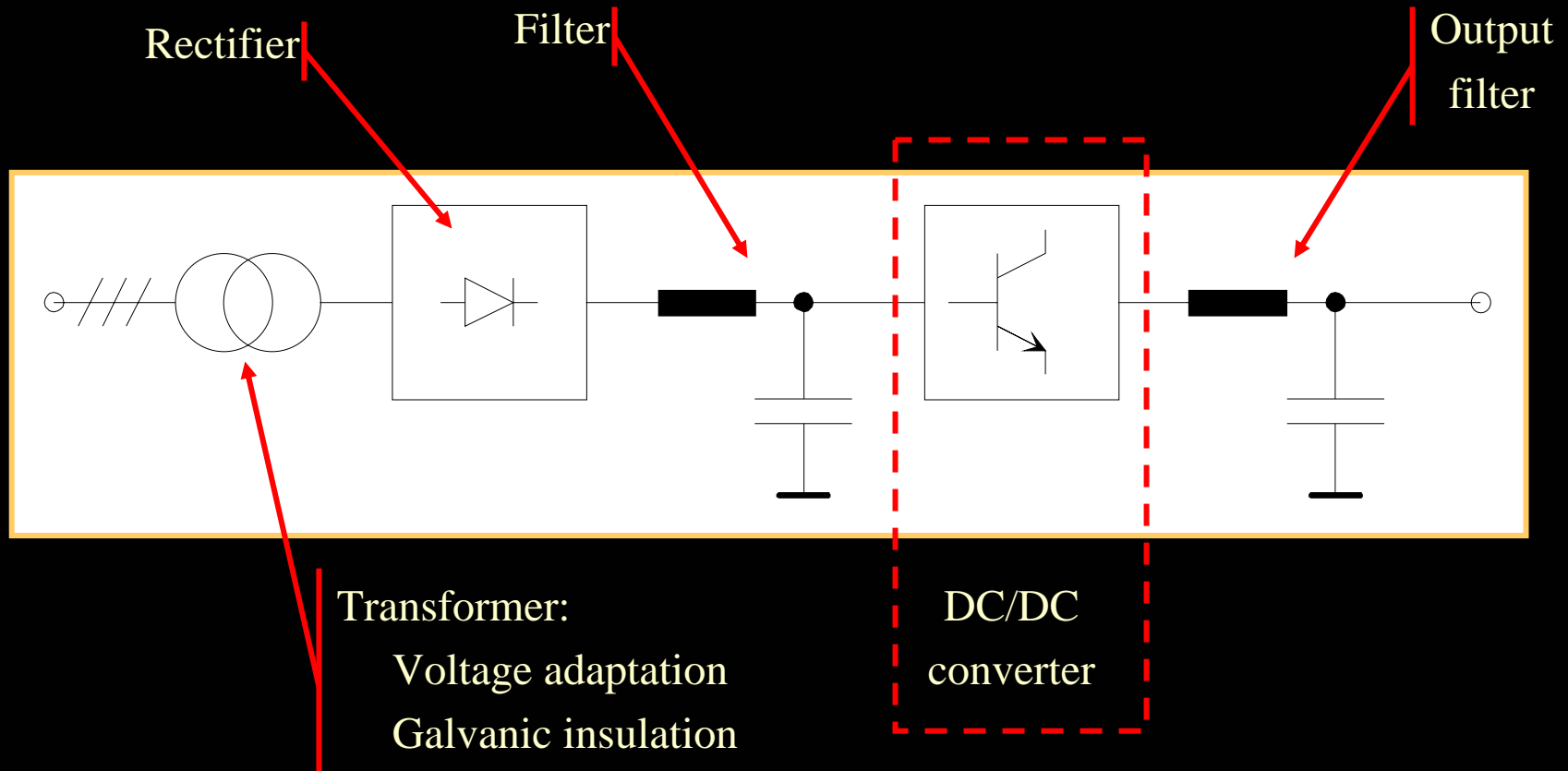

## Introduction

- DC supplies: principle
  - Typical (and possible) architecture
    - Transformer : size and weight (?)
    - Rectifier: generally a diode rectifier
      - ⇒ No regulation of the output voltage
    - Filter
      - ⇒ Theoretically, a LC filter is needed
      - ⇒ Taking into account the parasitic inductances of the AC network or the leakage inductances of the transformer, a single capacitor is generally used
      - ⇒ The aim of this filter is to supply the DC/DC converter with a voltage source
    - DC/DC converter: dedicated for the control and regulation of the output voltage. Theoretically, two solutions can be investigated:
      - ⇒ Linear converter
      - ⇒ Switched mode converter: then an LC (or C) output filter is needed to lower ripple.

# Introduction

- DC supplies: principle
  - Another typical (and possible) architecture

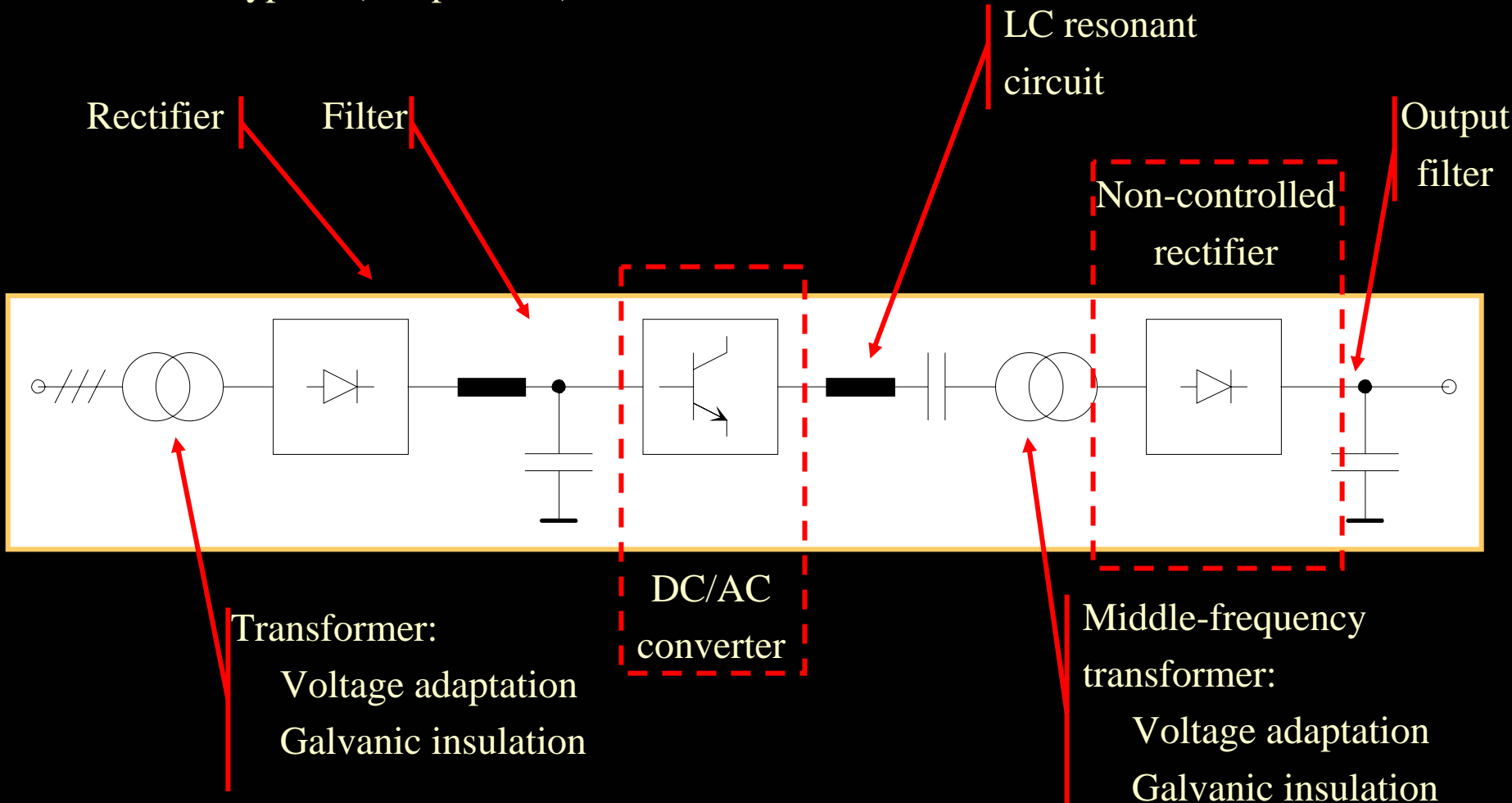

## Introduction

- DC supplies: principle
  - Another typical (and possible) architecture
    - Input Transformer (optional)
    - Rectifier, Filter
    - DC/AC converter
      - ⇒ In order to obtain transmit energy to an AC stage
    - LC resonant circuit (optional):
      - ⇒ For efficiency reasons, to obtain soft-switching condition for the DC/AC converter
    - Middle-frequency transformer:
      - ⇒ Voltage adaptation, Galvanic insulation
      - ⇒ Middle-frequency: reduction of weight and size
      - ⇒ Should avoid the use of the input transformer
    - Rectifier:
      - ⇒ Controlled or non-controlled, to obtain DC output voltage
      - ⇒ A LC (or C) filter is needed to lower ripple

# Introduction

- Linear or Switched mode converters
  - Linear converter
    - Transistor driven in its linear characteristics

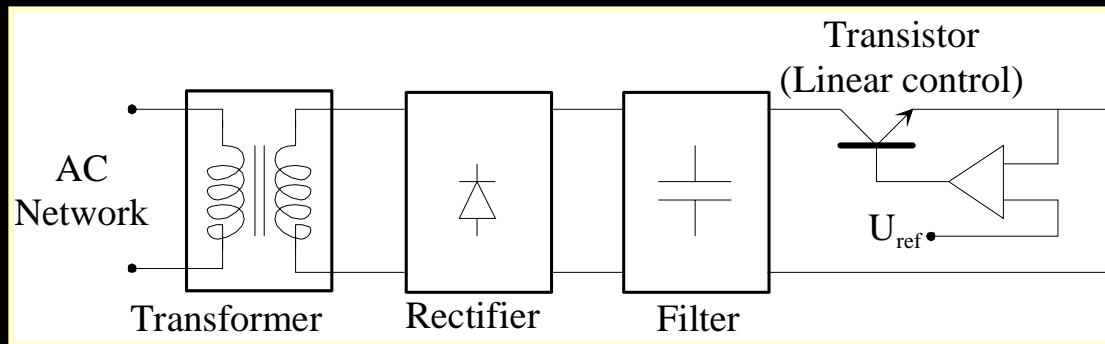

- Switched mode converter
  - Output filter to lower output voltage ripple

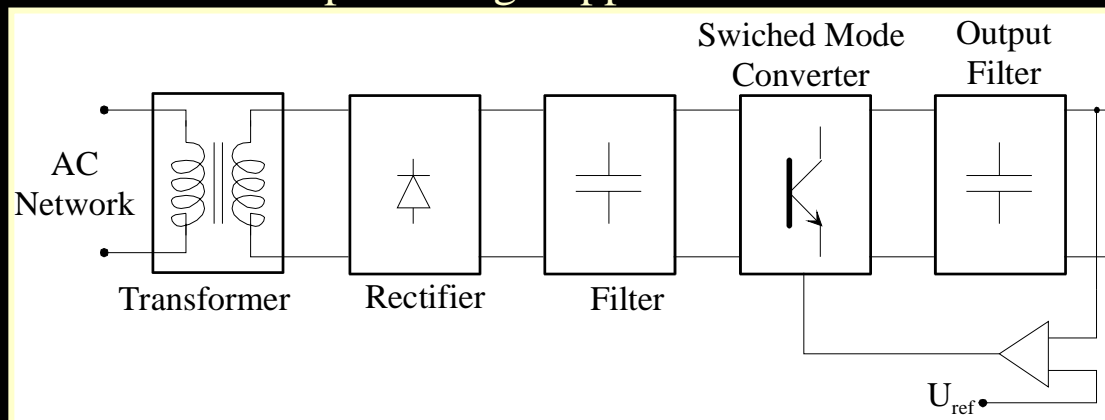



## Introduction

- Linear or Switched mode converters
  - Main properties: comparison

	Switched mode	Linear
Efficiency	65 à 90%	35 à 55%
Power per kilo	30 à 300W/kg	10 à 30W/kg
Power per l	50 à 300W/l	20 à 50W/l
Input voltage range	0.85 à 1.2U <sub>n</sub>	0.9 à 1.1U <sub>n</sub>
Dynamic	5% - 1ms	1% - 50us
Ouput voltage ripple	1%	0.1%
EMC	Importantes	Négligeables

- Main interest for using switched mode power converters
  - Efficiency
  - Power density

## Introduction

- Switched Mode Converters: main challenges

- Switched mode converter: Main topology

- Low frequency input filter (50Hz, 60Hz, 400Hz): size and weight!

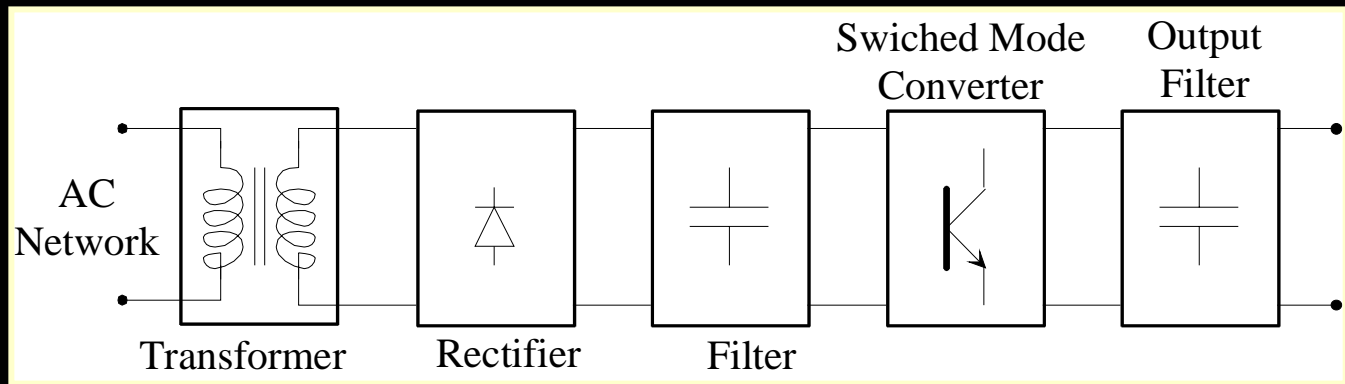

- Switched mode converter: DC/DC converter with transformer

- Middle frequency transformer: Switching frequency of the converter: size and weight...

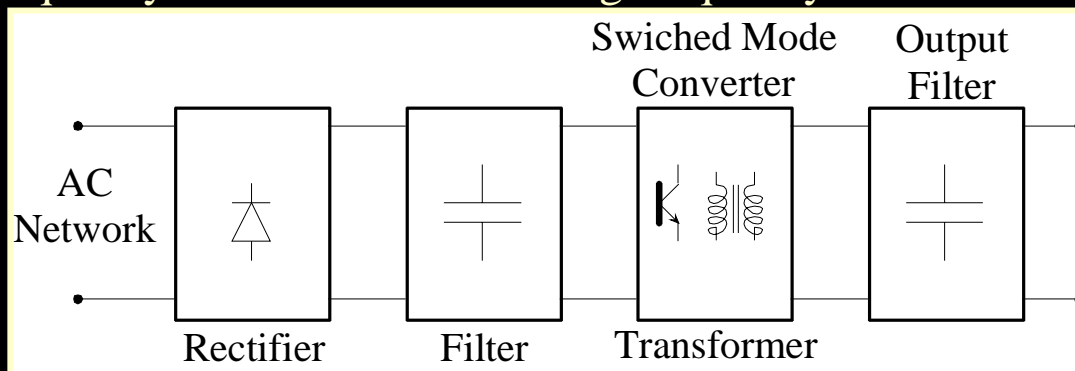

# Introduction

## Switched Mode Converters: Convention

- This contribution will focus on Switched Mode converter topologies
- (Input transformer) + Rectifier + Filter = Ideal voltage source

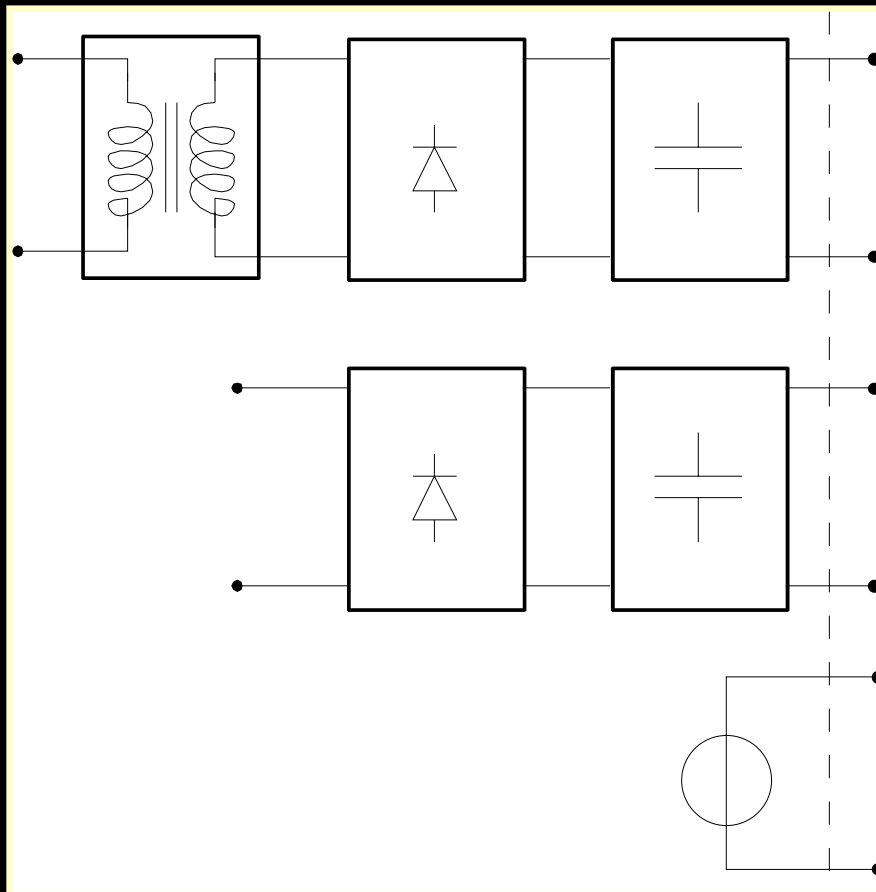

## DC/DC converters

### Introduction

- The aim of this presentation is to describe 1 quadrant switched mode converters
  - $U_s$  is the output voltage
  - $I_s$  is the output current
  - The power provided to the load is:

$$P_s = U_s I_s$$

- Depending on the topology and the components, DC/DC converters can be reversible or non-reversible
  - Converters affiliated with quadrant 1 ( $U_s > 0$  and  $I_s < 0$ ) will be considered

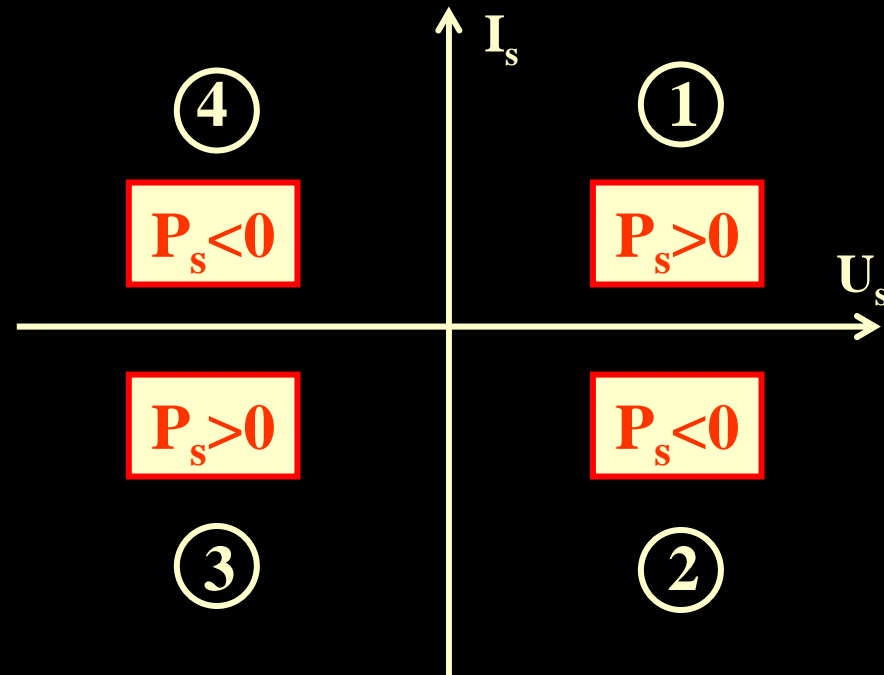

## DC/DC converters

- Introduction
  - The aim of direct DC/DC converter is to manage an energy transfer between
    - A DC voltage source and a DC current source (Buck or step-down converter)
      - ⇒ Such a converter allows the supply of loads with an adjustable voltage, lower than the input voltage
    - A DC current source and a DC voltage source (Boost or step-up converter)
      - ⇒ Such a converter allows the supply of loads with an adjustable voltage, higher than the input voltage
    - A DC voltage source and a second DC voltage source (Buck-boost or step-up/down converter)
      - ⇒ The control of the energy transfer between two voltage sources is allowed by an internal inductance, used as energy buffer in the energy flow process
      - ⇒ Such a converter allows the supply of loads with an adjustable voltage, higher or lower than the input voltage
      - ⇒ The buck-boost converter is not the association of a buck and a boost converters

## DC/DC Converters

- Buck (step-down) converter:
  - Topology

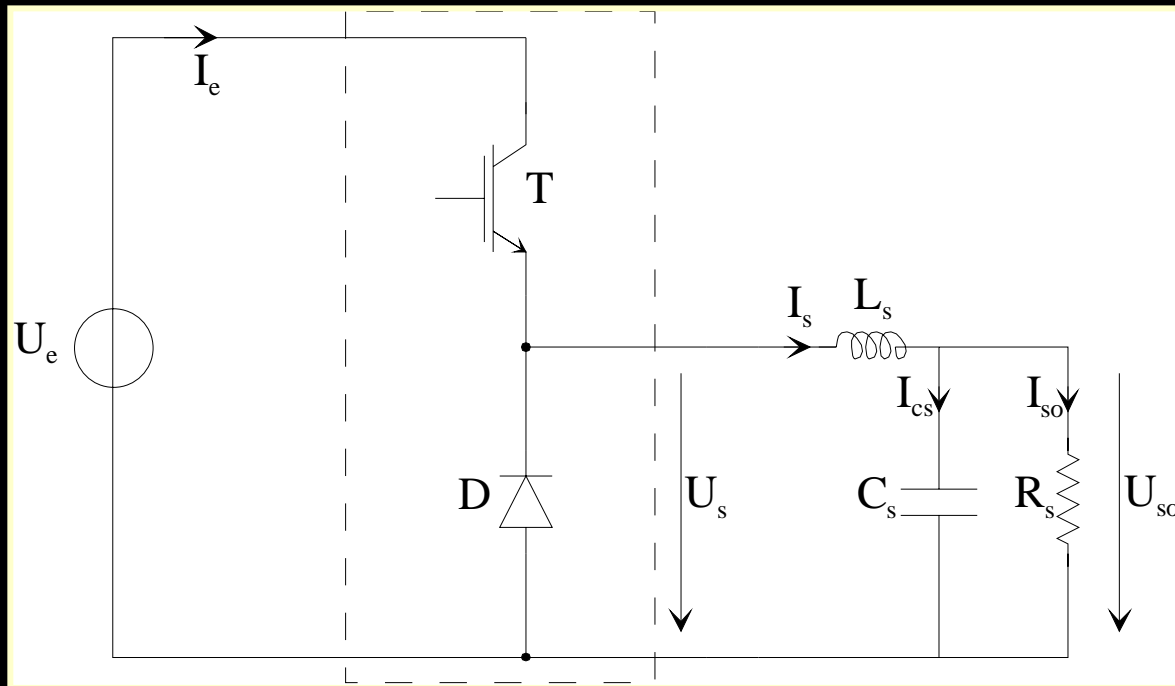

- 1 Switching cell: transistor + Diode
- Main parameter:
  - switching period  $T_s$

# DC/DC Converters

- Buck (step-down) converter:
  - Continuous conduction mode:
    - The output current  $I_s$  is always positive
    - Each off-switching of the diode is triggered by the on-switching of the transistor
  - Discontinuous conduction mode:
    - Each off-switching of the diode is due to a natural decrease of the output current to 0, while the transistor is not immediately switched on.

### Continuous conduction mode

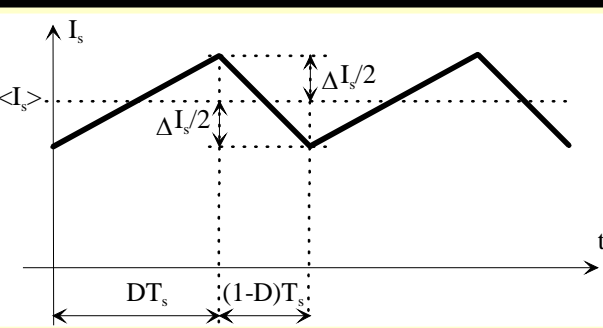

### Critical conduction mode

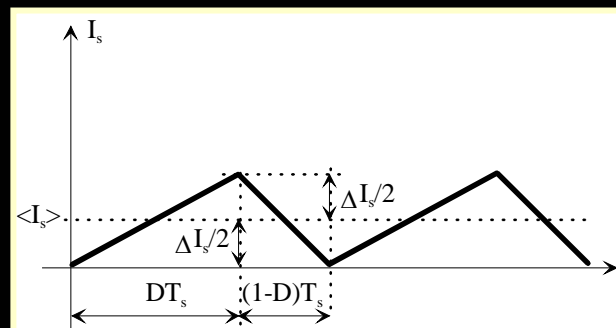

### Discontinuous conduction mode

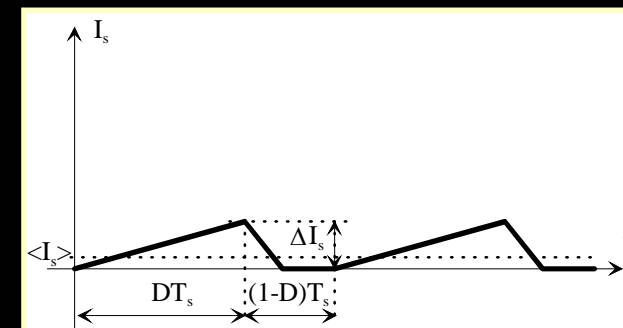

## DC/DC Converters

- Buck (step-down) converter:
  - Summary:

- Continuous conduction mode :

$$\langle U_s \rangle = U_{so} = \mathbf{D}U_e$$

$$y = \mathbf{D}$$

- Critical conduction :

$$\langle I_{s\text{lim}} \rangle = \frac{U_e}{2L_s f} (1 - \mathbf{D})\mathbf{D}$$

$$y = \frac{\langle U_s \rangle}{U_e} = \frac{U_{so}}{U_e}$$

$$x_{\text{lim}} = \frac{1}{2} y(1 - y)$$

- Discontinuous conduction mode

$$\langle U_s \rangle = U_{so} = U_e \frac{1}{1 + \frac{2L_s f \langle I_s \rangle}{D^2 U_e}}$$

$$x = \frac{L_s f \langle I_s \rangle}{U_e}$$

$$y = \frac{1}{1 + \frac{2x}{D^2}}$$



## DC/DC Converters

- Buck (step-down) converter:
  - Output characteristics

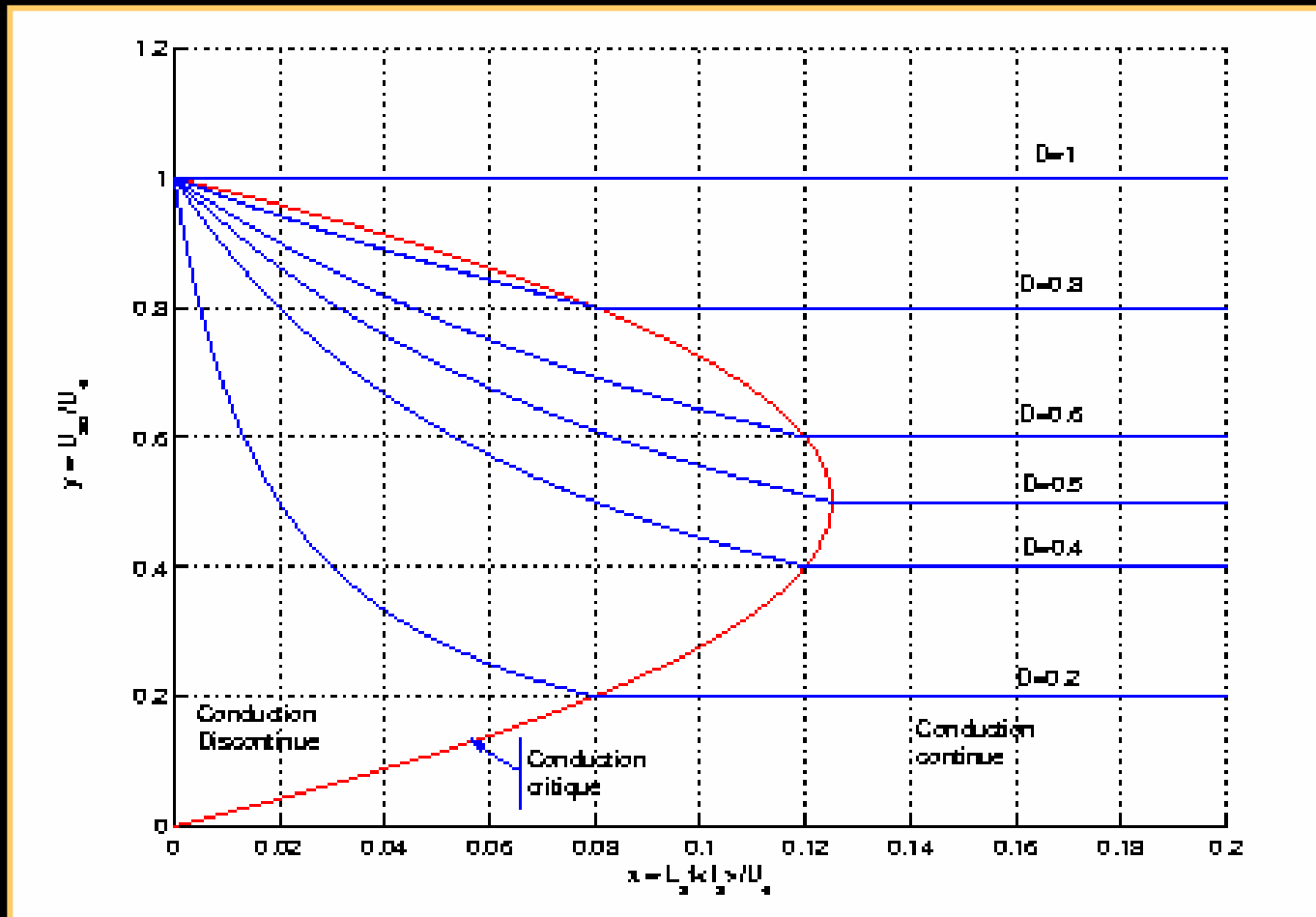

## DC/DC Converters

- Boost (step-up) converter:
  - Topology

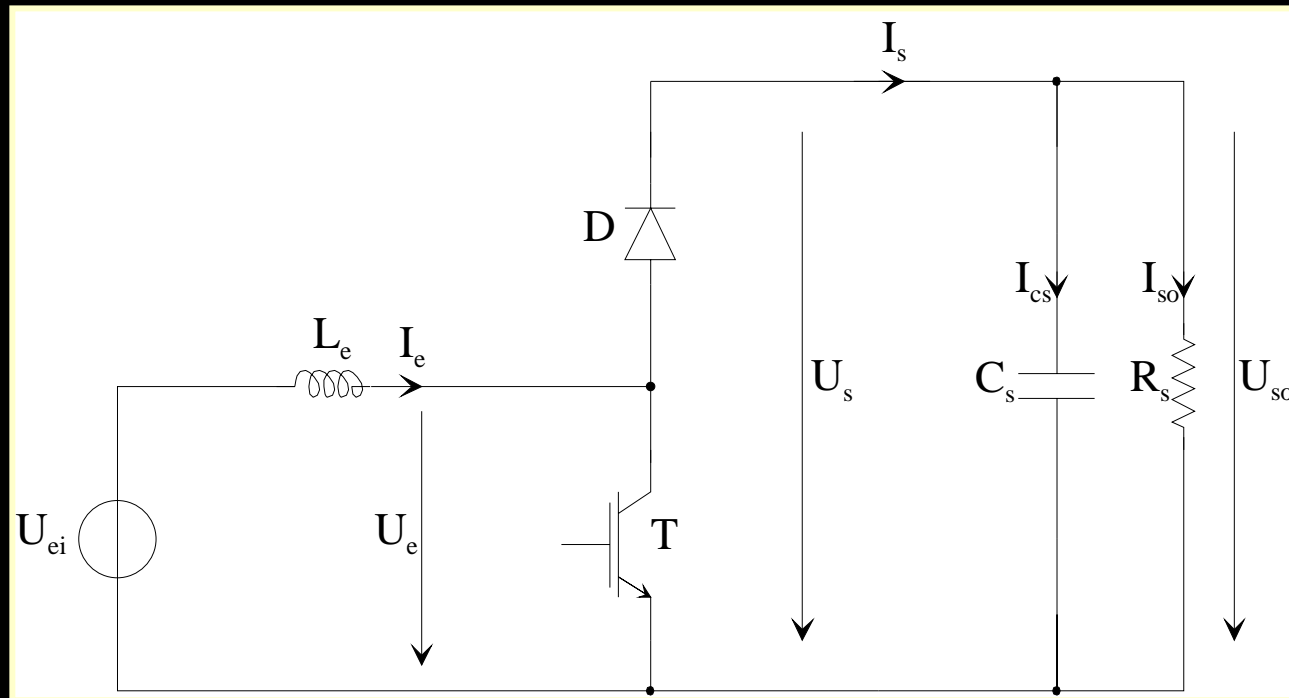

- 1 Switching cell: transistor+diode
- Main parameter
  - Switching period  $T_s$

# DC/DC Converters

- Boost (step-up) converter:
  - Continuous conduction mode:
    - The input current is always positive
    - Each off-switching of the diode is triggered by the on-switching of the transistor
  - Discontinuous conduction mode
    - Each off-switching of the diode is due to a natural decrease of the input current to 0, while the transistor is not immediately switched on.

## Continuous conduction mode

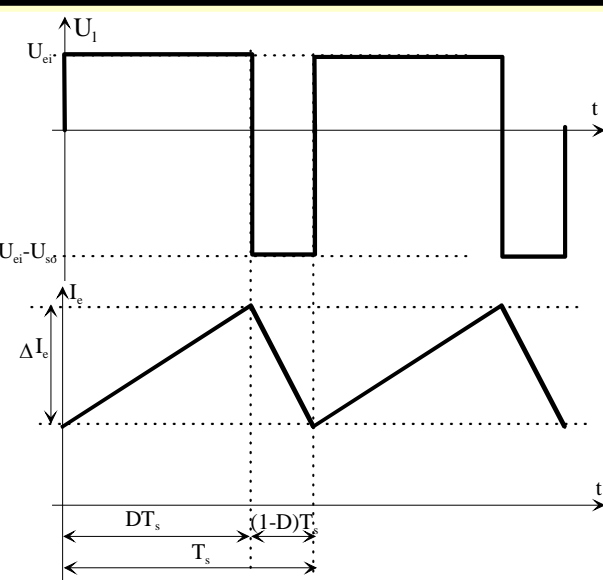

## Critical conduction mode

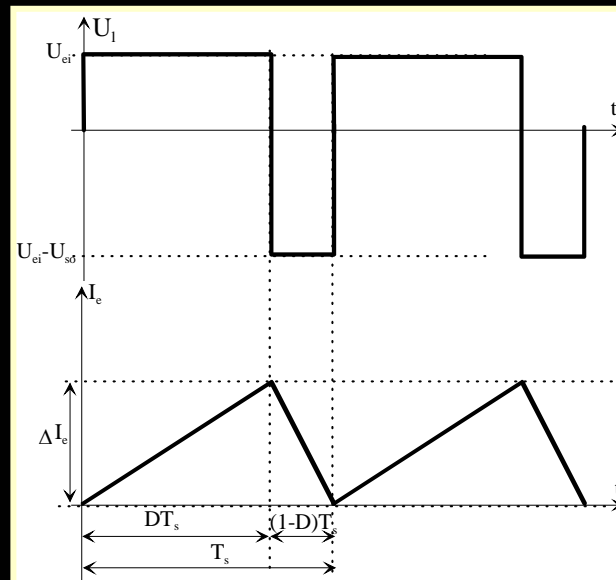

## Discontinuous conduction mode

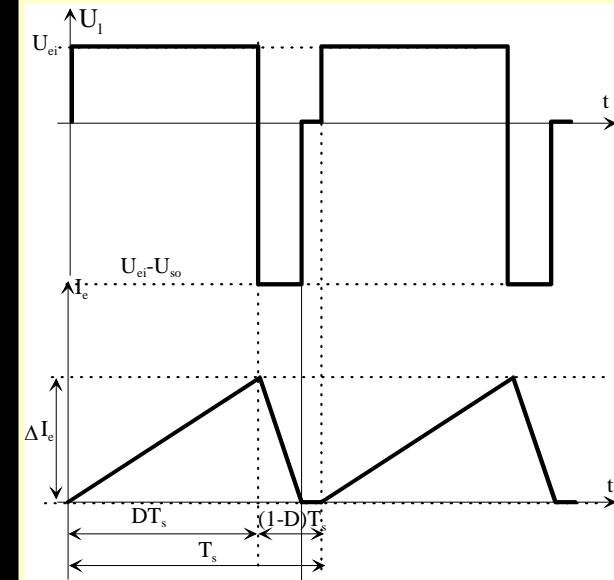

## DC/DC Converters

- Boost (step-up) converter:
  - Summary

- Continuous conduction mode :

$$\mathbf{U}_{so} = \langle \mathbf{U}_s \rangle = \mathbf{U}_{ei} \frac{\mathbf{1}}{\mathbf{1} - \mathbf{D}}$$

- Critical conduction

$$\langle \mathbf{I}_{s\text{lim}} \rangle = \frac{\mathbf{U}_{ei}}{2\mathbf{L}_e\mathbf{f}} (\mathbf{1} - \mathbf{D})\mathbf{D}$$

- Discontinuous conduction mode :

$$\langle \mathbf{U}_s \rangle = \mathbf{U}_{so} = \mathbf{U}_{ei} \left( \mathbf{1} + \frac{\mathbf{U}_{ei}}{2\mathbf{L}_e\mathbf{f} \langle \mathbf{I}_s \rangle} \mathbf{D}^2 \right)$$

**Normalized Variables**

$$\mathbf{y} = \frac{\langle \mathbf{U}_s \rangle}{\mathbf{U}_{ei}} = \frac{\mathbf{U}_{so}}{\mathbf{U}_{ei}}$$

$$\mathbf{x} = \frac{\mathbf{L}_e\mathbf{f} \langle \mathbf{I}_s \rangle}{\mathbf{U}_{ei}}$$

$$\mathbf{y} = \frac{\mathbf{1}}{\mathbf{1} - \mathbf{D}}$$

$$\mathbf{x}_{\text{lim}} = \frac{\mathbf{1}}{2} \frac{\mathbf{y} - \mathbf{1}}{\mathbf{y}^2}$$

$$\mathbf{y} = \mathbf{1} + \frac{\mathbf{D}^2}{2\mathbf{x}}$$

# DC/DC Converters

- Boost (step-up) converter:
  - Output Characteristics

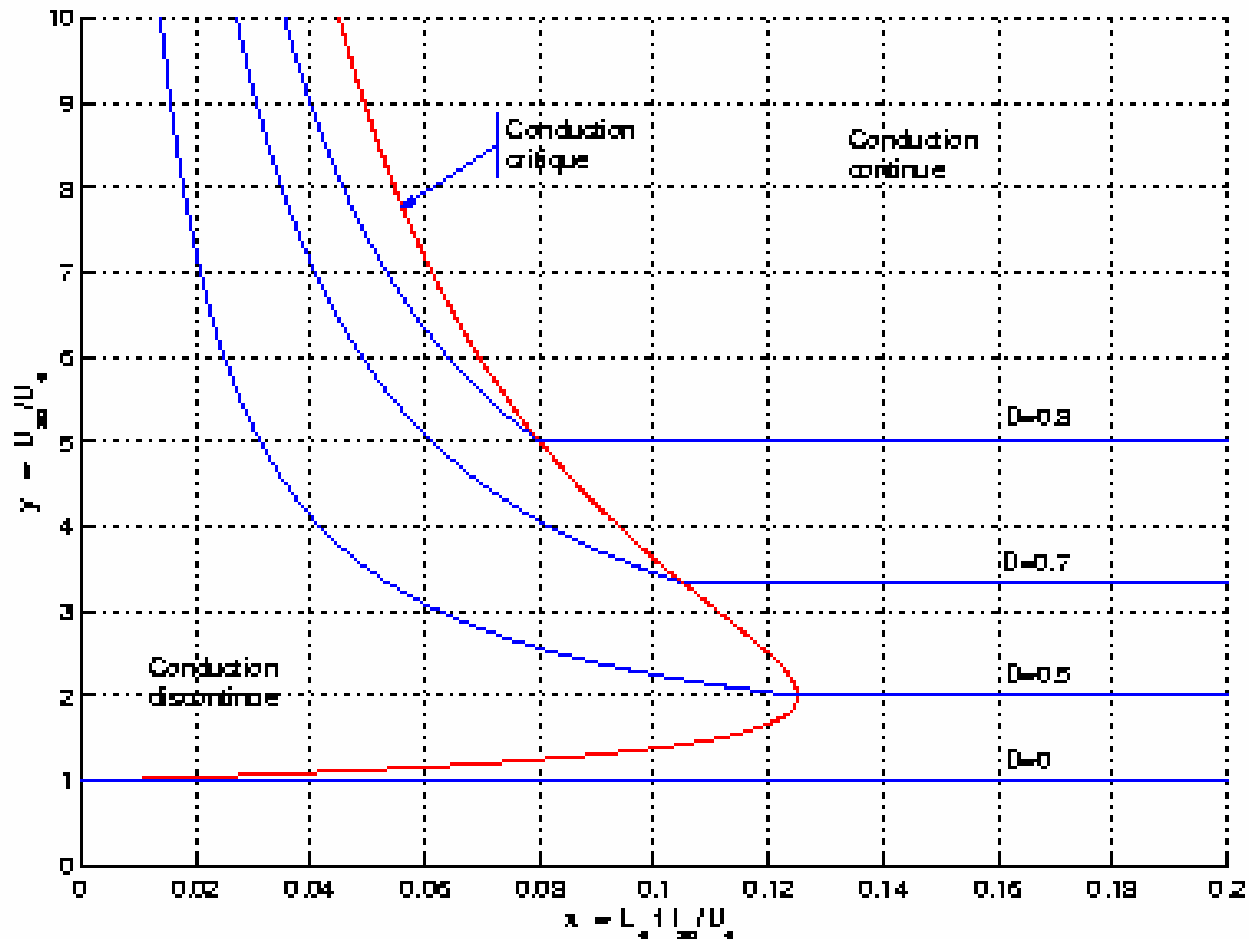

## DC/DC Converters

- Buck-Boost (step-up/down) converter:
  - Also known as DC/DC inverter
  - Topology

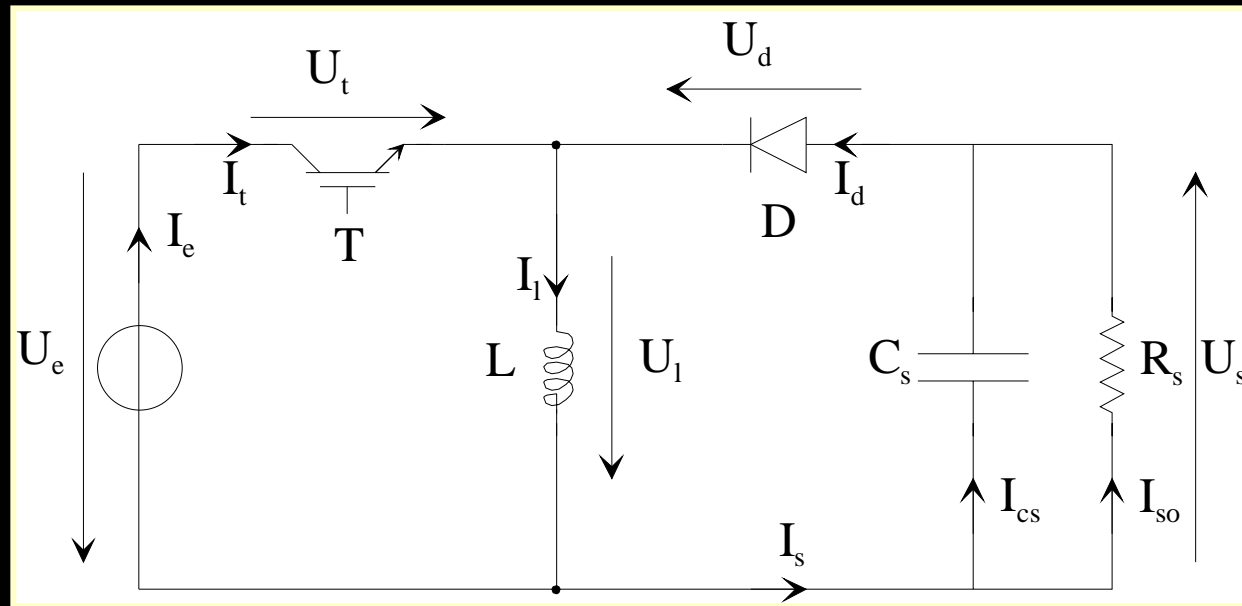

- Energy transfer between 2 voltage sources is allowed by the internal inductance  $L$
- 1 Switching cell: transistor+diode
- Main parameter
  - Switching period  $T_s$

# DC/DC Converters

- Buck-Boost (step-up/down) converter:
  - Continuous conduction mode:
    - The current in the inductor is always positive
    - Each off-switching of the diode is triggered by the on-switching of the transistor
  - Discontinuous conduction mode
    - Each off-switching of the diode is due to a natural decrease of the current in the inductor to 0, while the transistor is not immediately switched on.

Continuous conduction mode

Critical conduction mode

Discontinuous conduction mode

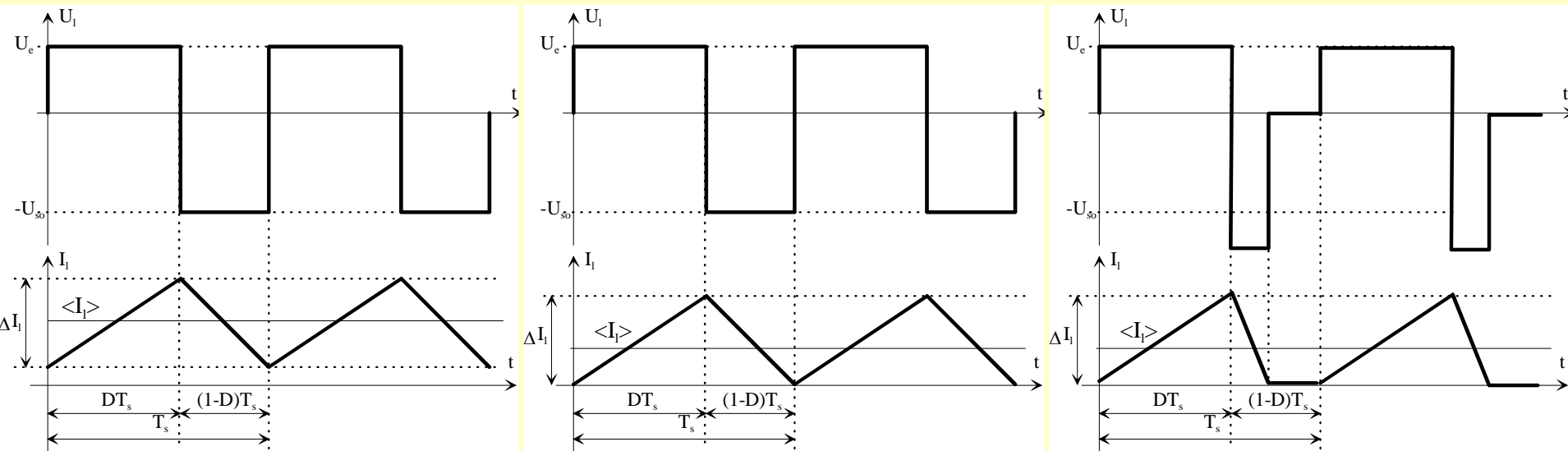

## DC/DC Converters

- Buck-Boost (step-up/down) converter:
  - Summary

- Continuous conduction mode :

$$U_{so} = \langle U_s \rangle = U_e \frac{D}{1-D}$$

$$y = \frac{D}{1-D}$$

- Critical conduction :

$$\langle I_{slim} \rangle = \frac{1}{2Lf} \frac{U_e^2 U_{so}}{(U_e + U_{so})^2}$$

$$y = \frac{\langle U_s \rangle}{U_e} = \frac{U_{so}}{U_e}$$

$$x_{lim} = \frac{1}{2} \frac{y}{(1+y)^2}$$

- Discontinuous conduction mode :

$$\langle U_s \rangle = U_{so} = U_e \left( \frac{U_e}{2Lf \langle I_s \rangle} D^2 \right)$$

$$x = \frac{Lf \langle I_s \rangle}{U_e}$$

$$y = \frac{D^2}{2x}$$

**Normalized Variables**



## DC/DC Converters

- Buck-Boost (step-up/down) converter:
  - Output Characteristics

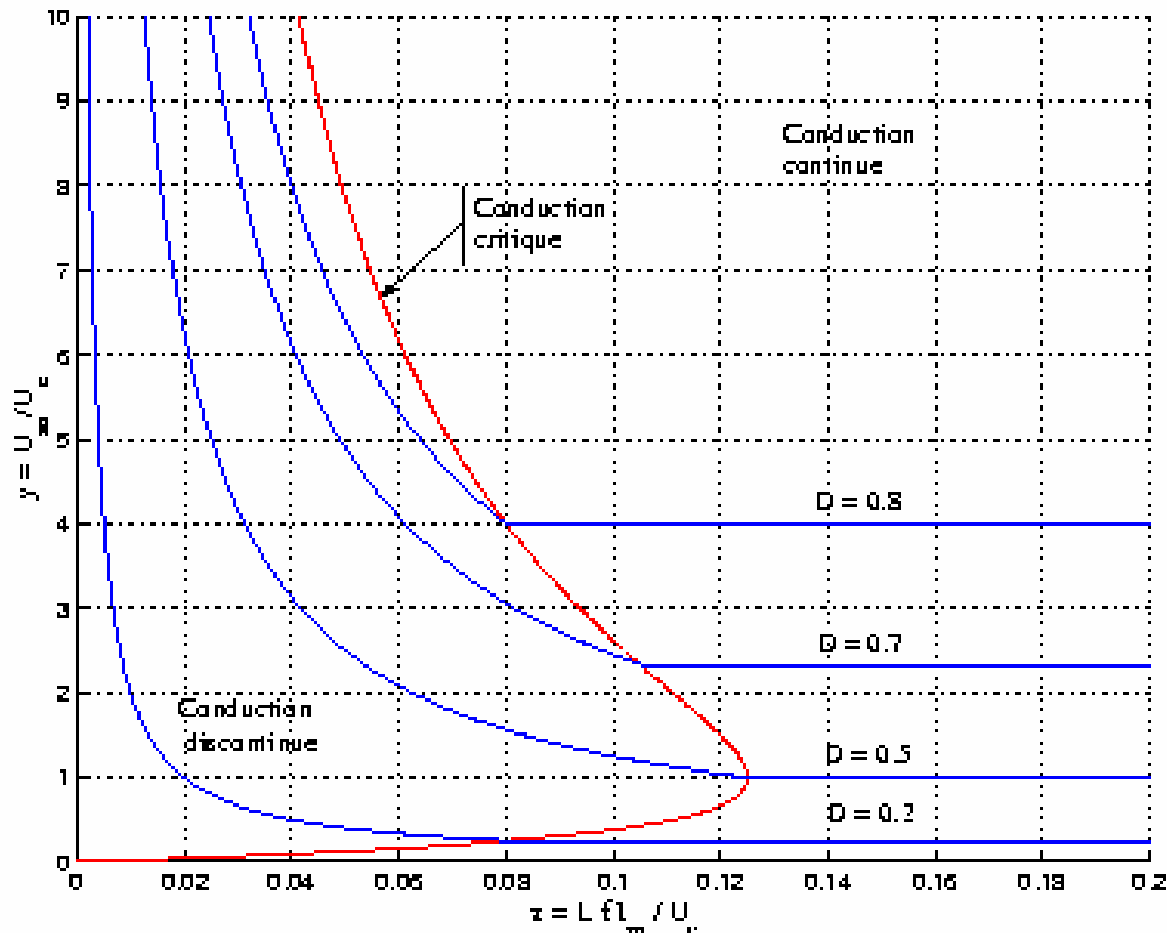

## DC/DC Converters

- Multi channels converters
  - Conventional buck or boost topologies,
  - Reduction of cooling devices
  - Increase of the efficiency
  - Soft-switching conditions
    - This can be obtained in the discontinuous conduction mode
      - ⇒ the off-switching of diodes is natural, and not due to the on-switching of transistors
      - ⇒ Switching current is 0A when transistors are switched on.

## DC/DC Converters

- Multi channels converters
  - Example of a multi-channel boost converter

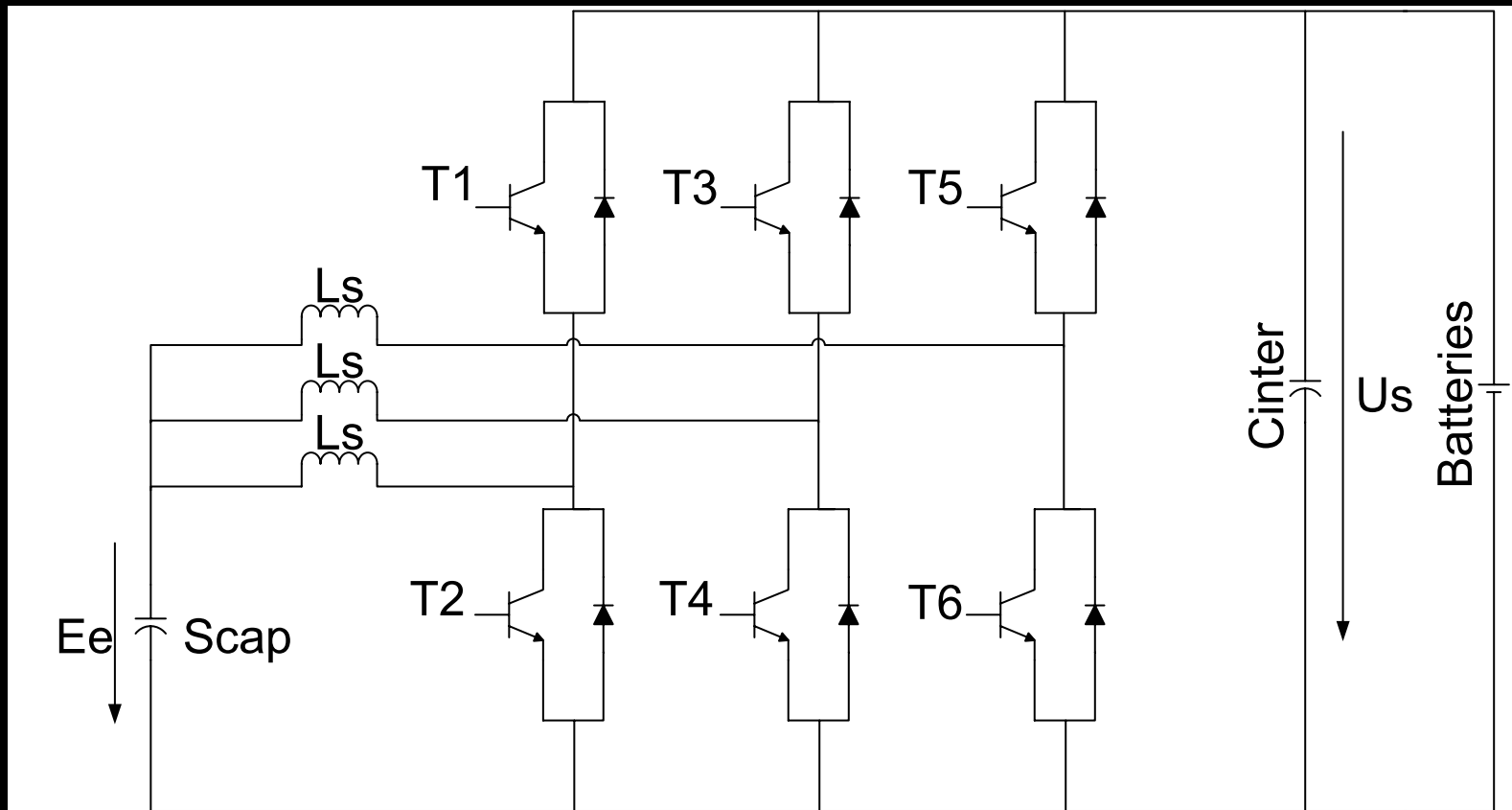

## DC/DC Converters

- Multi channels converters
  - Example of a multi-channel boost converter
    - Each channel works in discontinuous conduction mode
    - The associated coil is then reduced (few micro-henri)
    - Strong current ripple, poor averaged value
    - On the low-voltage source:
      - ⇒ averaged values of currents are summed
      - ⇒ As each leg is phase-shifted, current ripple are cancelled.
  - Such a solution offers high efficiency for applications of few kW.

# DC/DC Converters

- Multi channels converters
  - Example of a multi-channel boost converter

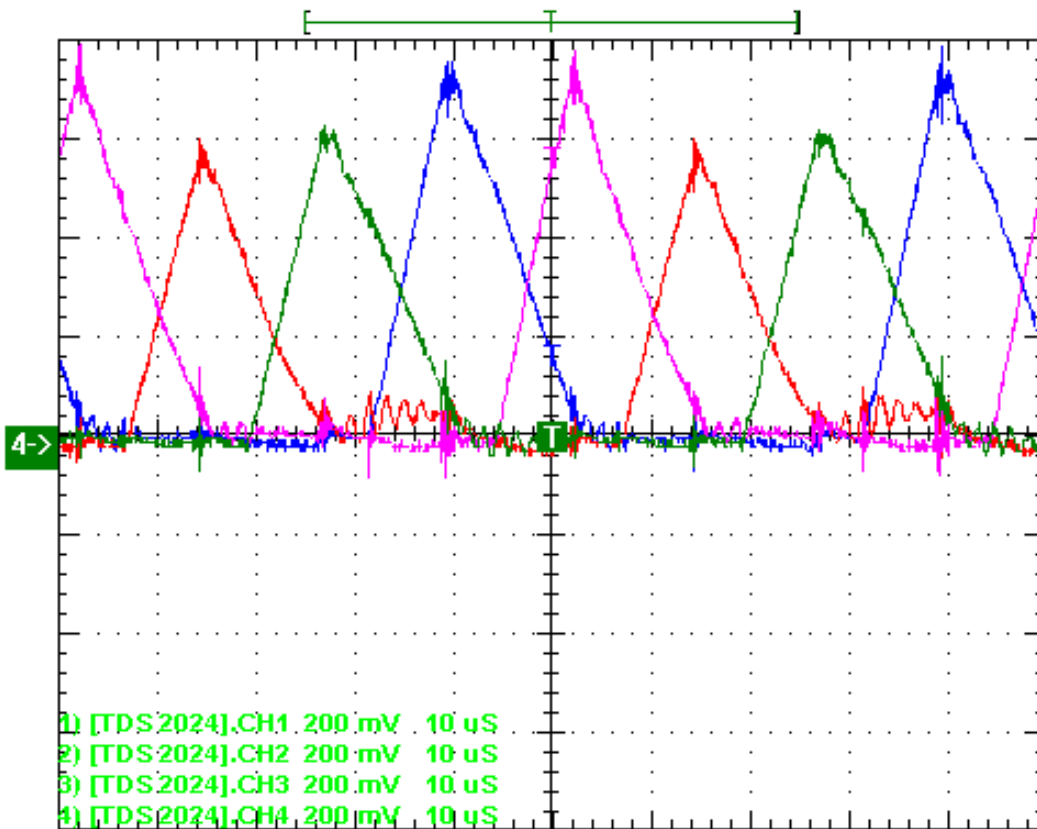

Current shown for 4 channels

$V_{in} = 18 \text{ V}$

$V_{out} = 37.5 - 75 \text{ V}$

$I_{in \text{ max}} = 255 \text{ A}$  (maximal power  
 4600 W)

Switching frequency : 20 kHz

8 channels

Inductors used : 7.8 uH

(typical inductor for a classical  
 converter : some mH)

## Transformers for DC/DC converters

- Principle, Model
  - In switched mode converters, transformers are needed
    - To adapt voltage/current levels
    - To offer galvanic insulation

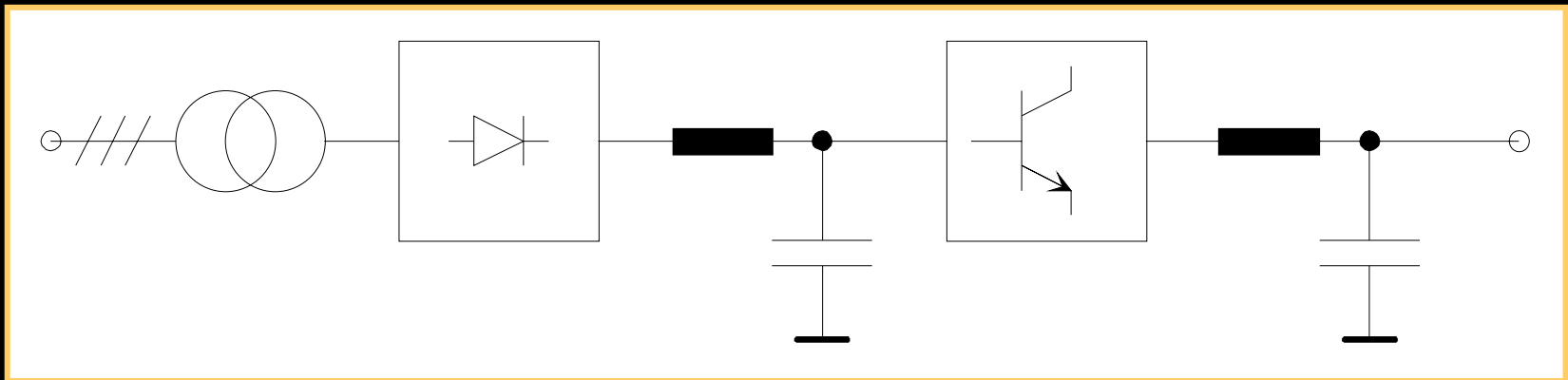

- In several applications, transformers are the first devices in the energy-flow chain:
  - Sizing?
  - Volume?
  - Weight?

## Transformers for DC/DC converters

- Principle, Model
  - General equations of a transformer:
    - Principle of a 2 windings transformer

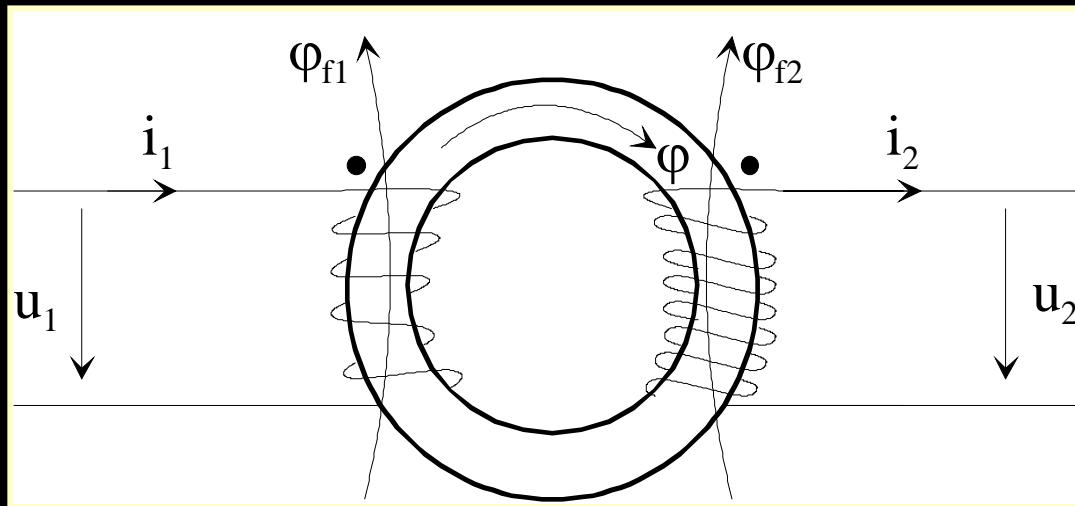

- Sign conventions
  - $\Rightarrow$  Voltages and currents are positives regarding conventions adopted in the figure

## Transformers for DC/DC converters

- Principle, Model
  - General equations of a transformer:
    - First hypothesis:
      - ⇒ No leakage flux
      - ⇒ Reluctance of the magnetic circuit is 0
      - ⇒ Windings with no electric resistance

$$\begin{aligned}
 u_1 &= n_1 \frac{d\phi}{dt} \\
 u_2 &= n_2 \frac{d\phi}{dt}
 \end{aligned}
 \Rightarrow \frac{u_2}{u_1} = \frac{n_2}{n_1} = m$$

$$\begin{aligned}
 n_1 i_1 - n_2 i_2 &= \mathcal{R} \phi = 0 \\
 \Rightarrow \frac{i_1}{i_2} &= \frac{n_2}{n_1} = m
 \end{aligned}$$

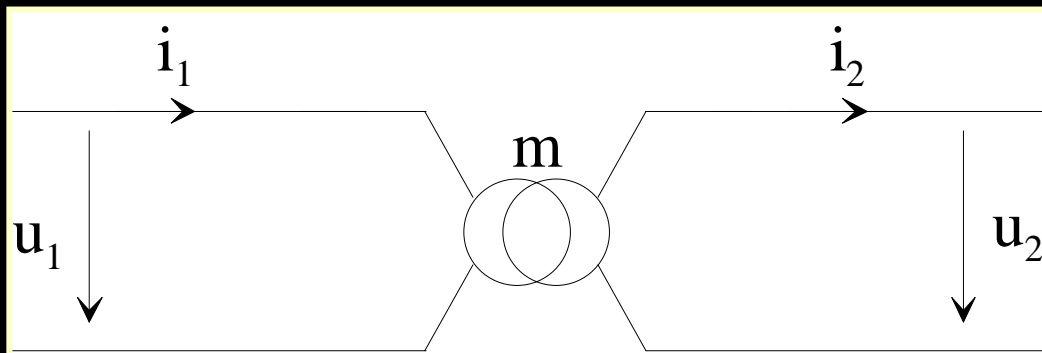



## Transformers for DC/DC converters

- Principle, Model

- General equations of a transformer:

- Second hypothesis:

- ⇒ No leakage flux

- ⇒ Reluctance of the magnetic circuit

- ⇒ Windings with no electric resistance

$$n_1 i_1 - n_2 i_2 = \mathcal{R} \varphi \quad \Rightarrow \quad i_1 = \underbrace{\frac{n_2}{n_1} i_2}_{\text{Ideal transformer}} + \underbrace{\frac{\mathcal{R}}{n_1} \varphi}_{i_\mu}$$

$$\varphi_t = n_1 \varphi \quad \Rightarrow \quad \varphi_t = \frac{n_1^2}{\underbrace{\mathcal{R}}_{L_m}} i_\mu$$

- $L_m$ : magnetic inductance of the transformer

## Transformers for DC/DC converters

- Principle, Model

- General equations of a transformer:

- $L_m$ : magnetic inductance of the transformer

$$u_1 = L_M \frac{di_\mu}{dt}$$

⇒ The primary mean value of the voltage must be 0

- Magnetic energy stored into a transformer:

$$W = \frac{1}{2} L_M i_\mu^2 = \frac{1}{2} \mathfrak{R} \varphi^2$$

⇒ The energy stored into the transformer cannot be discontinuous

- The flux is then a state variable

- Currents:

$$n_1 i_1 - n_2 i_2 = \mathfrak{R} \varphi$$

⇒ Each discontinuity of the input current must be compensated by an equivalent discontinuity of the secondary side current

## Transformers for DC/DC converters

- Principle, Model
  - General equations of a transformer:
    - third hypothesis:
      - ⇒ Leakage flux
      - ⇒ Reluctance of the magnetic circuit
      - ⇒ Windings with no electric resistance

$$u_1 = n_1 \underbrace{\frac{d\varphi}{dt}}_{e_1} + n_1 \frac{d\varphi_{f1}}{dt}$$

$$u_2 = n_2 \underbrace{\frac{d\varphi}{dt}}_{e_2} + n_2 \frac{d\varphi_{f2}}{dt}$$

$$\frac{e_2}{e_1} = \frac{n_2}{n_1} = m$$

## Transformers for DC/DC converters

- Principle, Model
  - General equations of a transformer:
    - third hypothesis:
      - ⇒ Leakage flux
      - ⇒ Reluctance of the magnetic circuit
      - ⇒ Windings with no electric resistance
    - Introducing the notion of leakage inductances (considering that  $\varphi_{f1}$  and  $\varphi_{f2}$  are directly proportional to the primary and secondary currents)

$$\begin{array}{l}
 n_1 \frac{d\varphi_{f1}}{dt} = l_1 \frac{di_1}{dt} \\
 n_2 \frac{d\varphi_{f2}}{dt} = -l_2 \frac{di_2}{dt}
 \end{array}
 \Rightarrow
 \begin{array}{l}
 u_1 = e_1 + l_1 \frac{di_1}{dt} \\
 u_2 = e_2 + l_2 \frac{di_2}{dt}
 \end{array}$$

## Transformers for DC/DC converters

- Principle, Model

- Model

- Resistance of windings are neglected
    - Hysteresis and iron losses are not taken into account

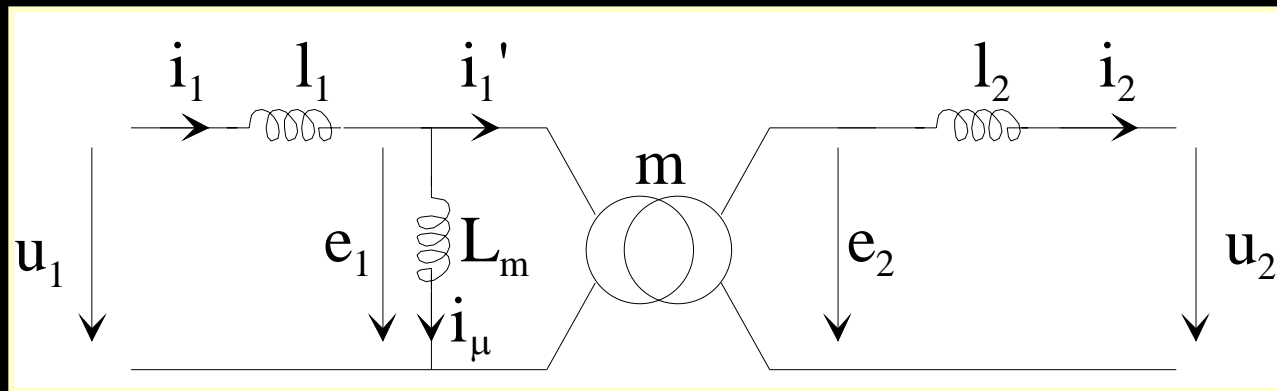

$l_1$  and  $l_2$   $\square$   $L_m$

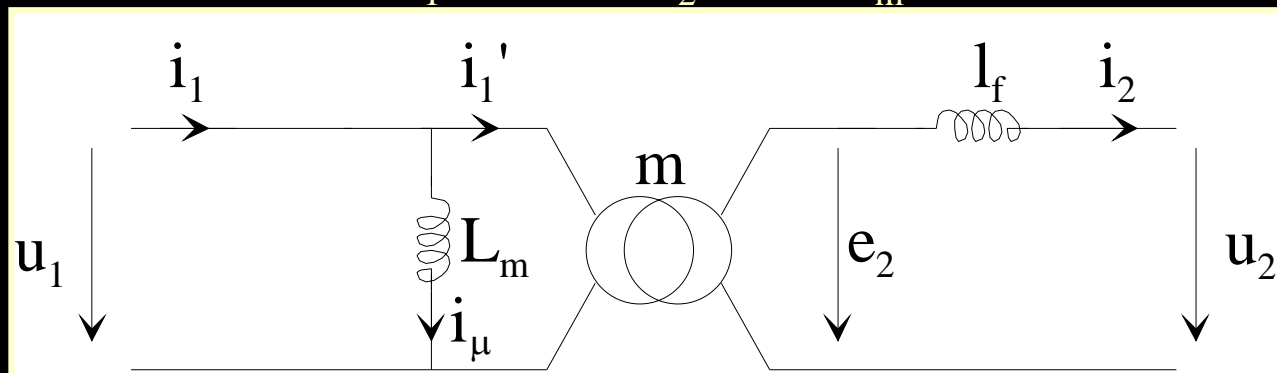

## Transformers for DC/DC converters

- Sizing of a transformer:

- Main equations:

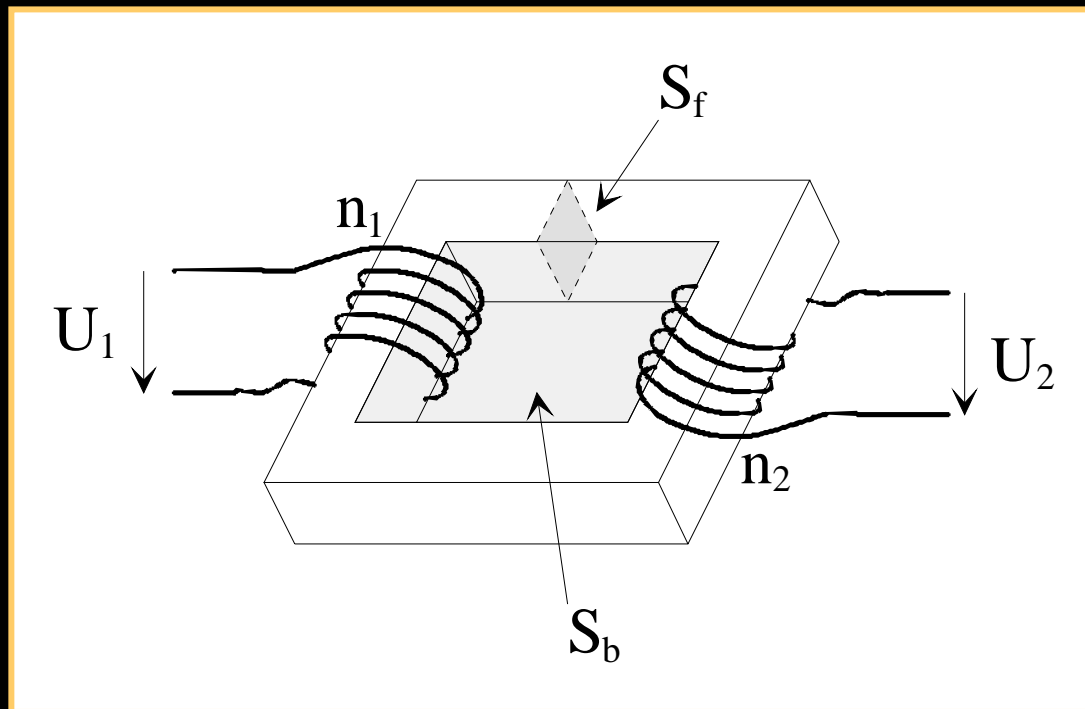

- $S_f$  : section of the magnetic circuit
- $S_b$  : surface allowed for windings

## Transformers for DC/DC converters

- Sizing of a transformer:
  - Main equations: surface of the magnetic circuit

$$u_1(t) = n_1 \frac{d\varphi}{dt}$$

$$\varphi = BS_f \Rightarrow u_1(t) = n_1 S_f \frac{dB}{dt}$$

$$B = \frac{1}{n_1 S_f} \int u_1(t) dt$$

$$\Rightarrow B_M = \frac{U}{n_1 S_f f}$$

$$\Rightarrow S_f = \frac{U}{n_1 B_M f}$$

## Transformers for DC/DC converters

- Sizing of a transformer:

- Main equations: surface allowed for windings

$$S_b = n_1 s_1 K_{b1} + n_2 s_2 K_{b2} + \dots + n_N s_N K_{bN}$$

$$S_b = n_1 \frac{I_{1\text{eff}}}{J_1} K_{b1} + n_2 \frac{I_{2\text{eff}}}{J_2} K_{b2} + \dots + n_N \frac{I_{N\text{eff}}}{J_N} K_{bN}$$

u sin g :  $n_i I_{i\text{eff}} = a_i n_1 I_{1\text{eff}}$

$$S_b = n_1 I_{1\text{eff}} \sum_{i=1}^N \frac{a_i K_{bi}}{J_i}$$



## Transformers for DC/DC converters

- Sizing of a transformer:

- Main equations: definition of  $A_{TR}$ , defining the volume of the transformer

$$A_{TR} = S_f S_b$$

$$A_{TR} = \frac{UI_{1eff}}{B_M f} \sum_{i=1}^N \frac{a_i K_{bi}}{J_i}$$

$$A_{TR} = \frac{P_1}{B_M f} \sum_{i=1}^N \frac{a_i K_{bi}}{J_i}$$

- The volume of the transformer (and its weight) are directly linked to
  - The power
  - The frequency
- The frequency has to be increased to lower volume and weight

## DC/DC converters with transformers

### General principle

- Such converters are identified from the conventional DC/DC converters
  - In conventional energy transfer chain, transformers are directly coupled to a low frequency power network

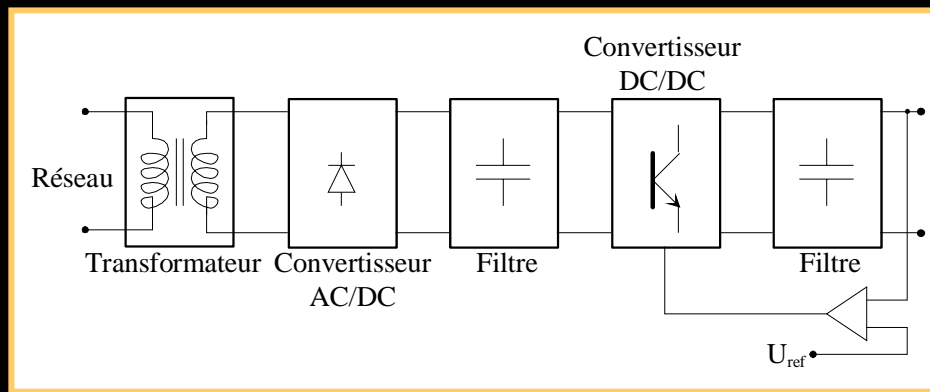

- The transformer can be integrated directly into the DC/DC converter (when possible)

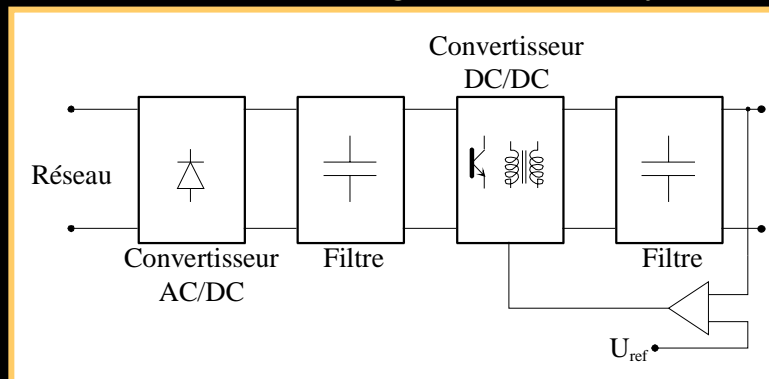

The working frequency is given by the switching frequency of the converter

## DC/DC converters with transformers

- General principle
  - Such converters are located directly of rectifier and an input filter
    - Convention:

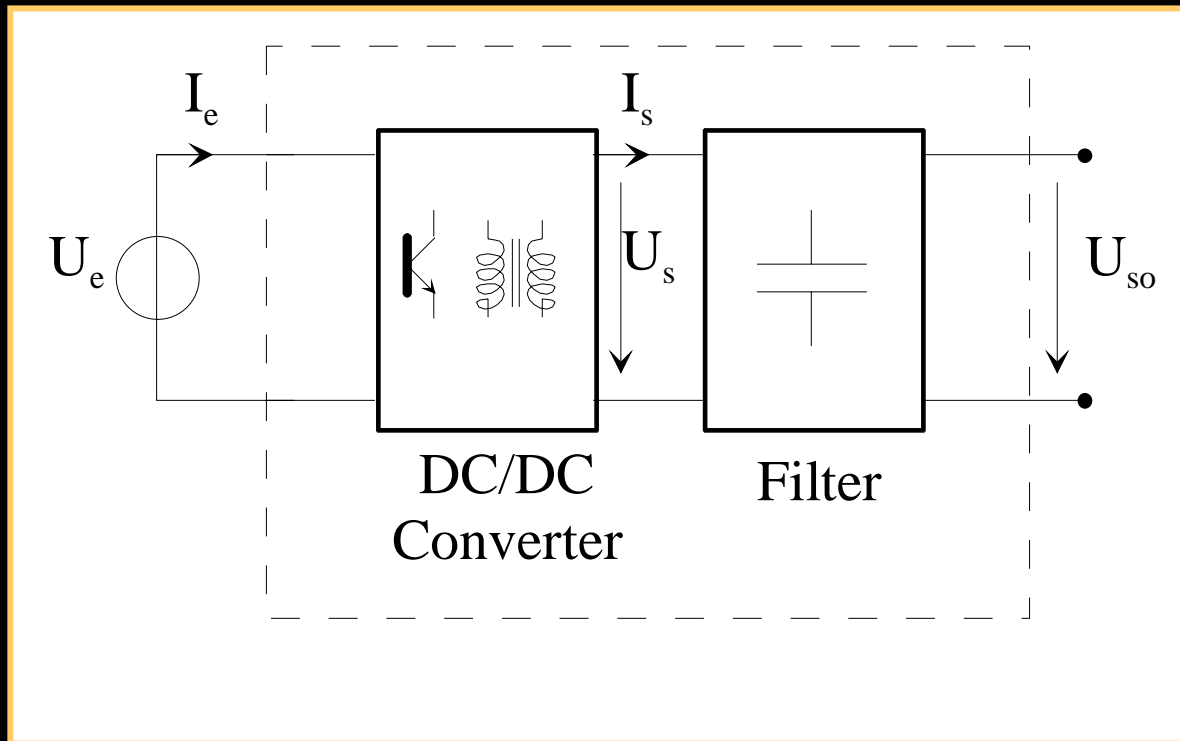

## DC/DC converters with transformers

- Flyback:

- Converter deduced from the DC/DC Buck-boost converter

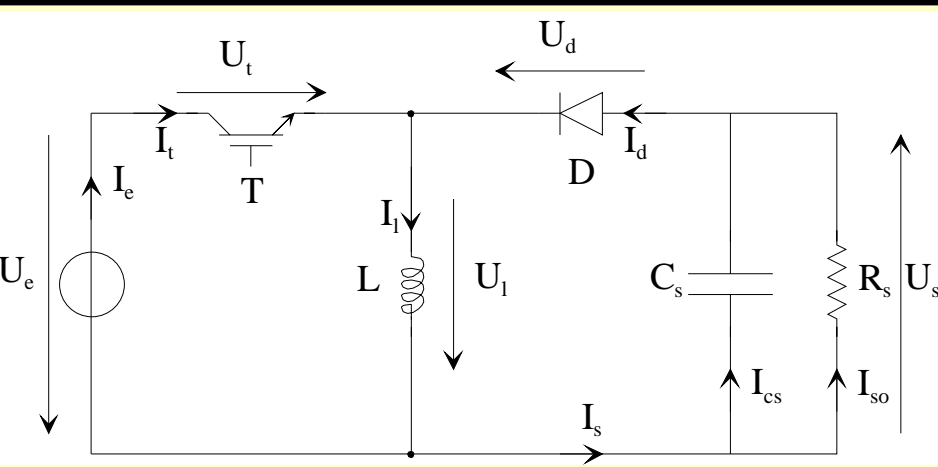

- When the transistor is ON, L is coupled to  $U_e$
- When the diode is ON, L is coupled to the output
- Magnetic energy is alternatively stored in L from  $U_e$ , and then provided to the output
- The mean value of  $U_l$  is 0

- When the transistor is ON, the primary side of the transformer is coupled to  $U_e$

- When the diode is ON, the secondary side is coupled to the output

- Magnetic energy is alternatively stored in  $L_m$  and then provided to the output

- The mean value of  $u_l$  is 0

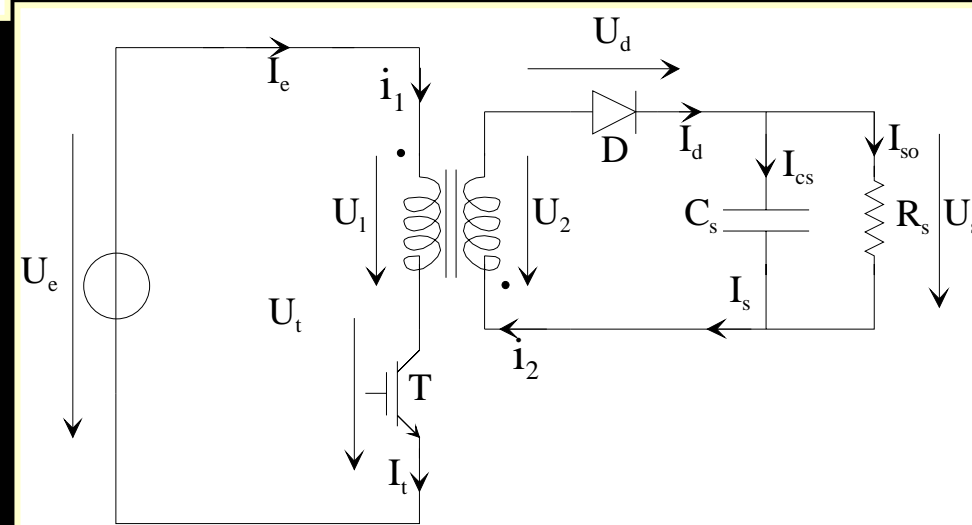

# DC/DC converters with transformers

- Flyback:
  - Continuous conduction mode:
    - Voltages and currents waveforms

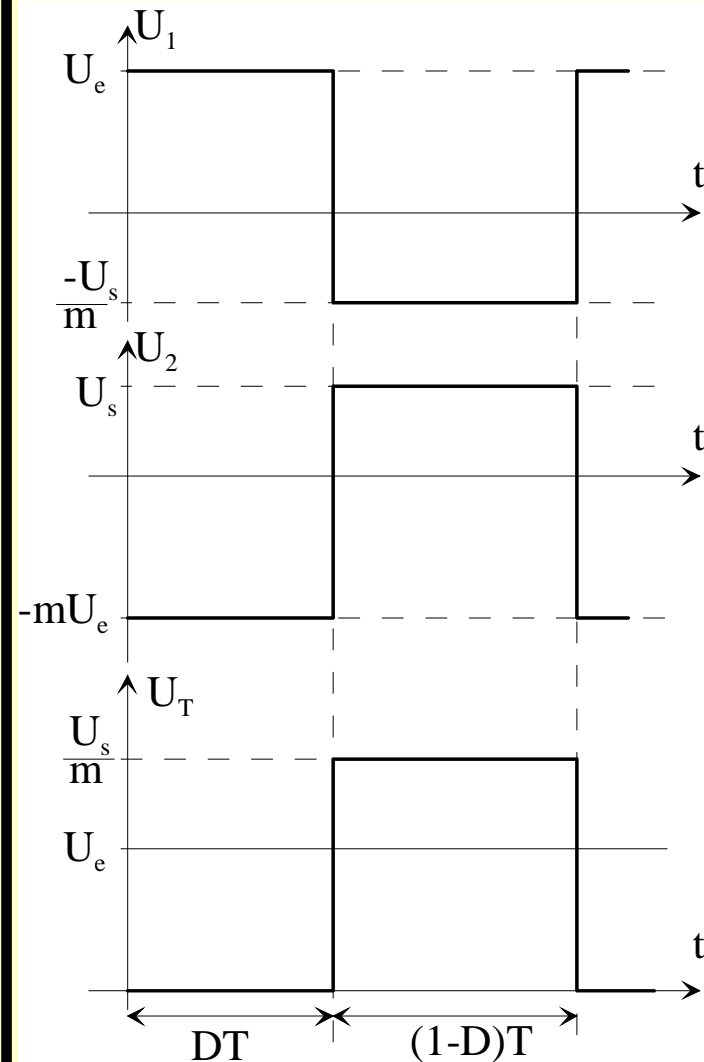
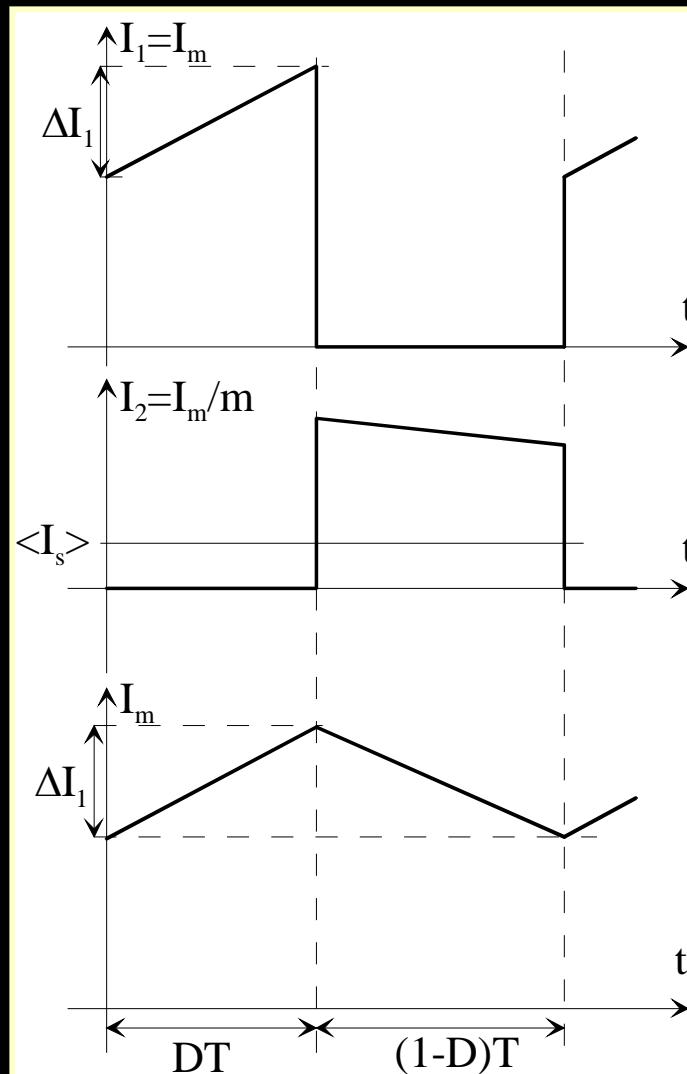

**Transistor ON:**  
 Energy is stored into the transformer

**Transistor OFF:**  
 Part of the stored energy is transmitted to the output

## DC/DC converters with transformers

- Flyback:

- Continuous conduction mode:

- Voltages and currents waveforms

⇒ The transistor has to be able to support not only the input voltage but:

$$U_T > U_e + \frac{1}{m} U_s$$

⇒ As energy needs to be stored into the transformer, the magnetic circuit can be huge

⇒ Strong fluctuations of secondary and primary currents, with leakage inductances: strong constraints on the components

## DC/DC converters with transformers

- Flyback:

- Continuous conduction mode:

- Main equations:

⇒ Duty cycle  $D$ : ratio between transistor conduction time and the switching period

$$D = \frac{t_1}{T}$$

⇒ Output voltage

$$U_{so} = \langle U_s \rangle = m \frac{D}{1-D} U_e$$

⇒ Current ripple: linked to the magnetization inductance

$$\Delta I_1 = \frac{U_e}{L_M f} D$$

⇒ Input and output currents

$$\langle I_e \rangle = \frac{D}{1-D} \langle I_s \rangle = \frac{D}{1-D} I_{so}$$

# DC/DC converters with transformers

- Flyback:
  - Discontinuous conduction mode:
    - Voltages and currents waveforms

Transistor ON:

Energy is stored into the transformer

Transistor OFF:

Part of the stored energy is transmitted to the output

The demagnetization of the transformer is completed before the ON switching of the transistor

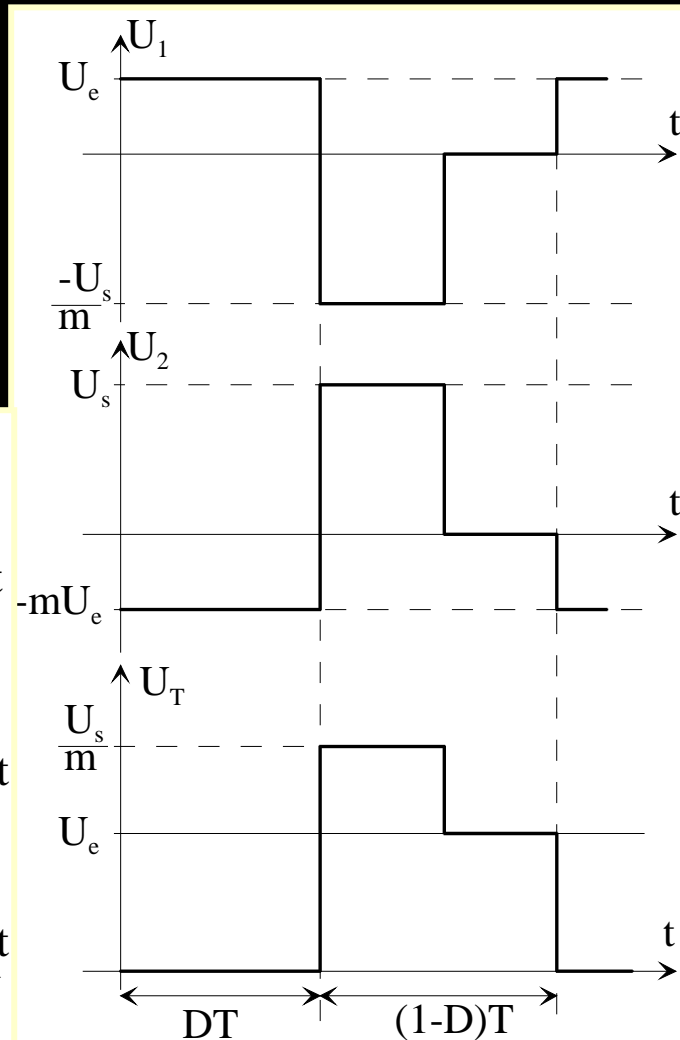
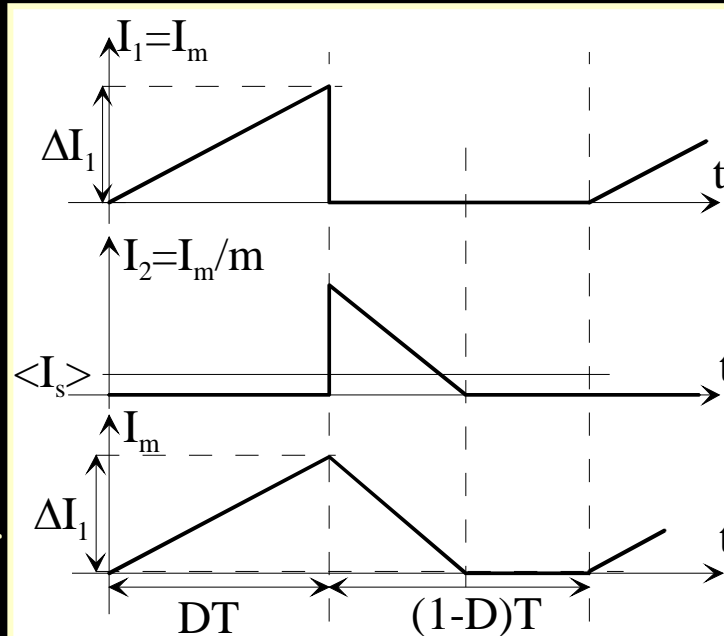



## DC/DC converters with transformers

- Flyback:

- Discontinuous conduction mode:

- Voltages and currents waveforms

⇒ The transistor has to be able to support not only the input voltage but:

$$U_T > U_e + \frac{1}{m} U_s$$

⇒ As energy needs to be stored into the transformer, the magnetic circuit can be huge, but less than the case of the continuous conduction mode

⇒ Strong fluctuations of secondary and primary currents, regarding their mean values

⇒ The output voltage is no more dependant of the transformation ratio  $m$ , but dependent of the load:

$$U_{so} = \langle U_s \rangle = D U_e \sqrt{\frac{R}{2L_m f}}$$

## DC/DC converters with transformers

- Forward

- Converter deduced from the DC/DC Buck converter

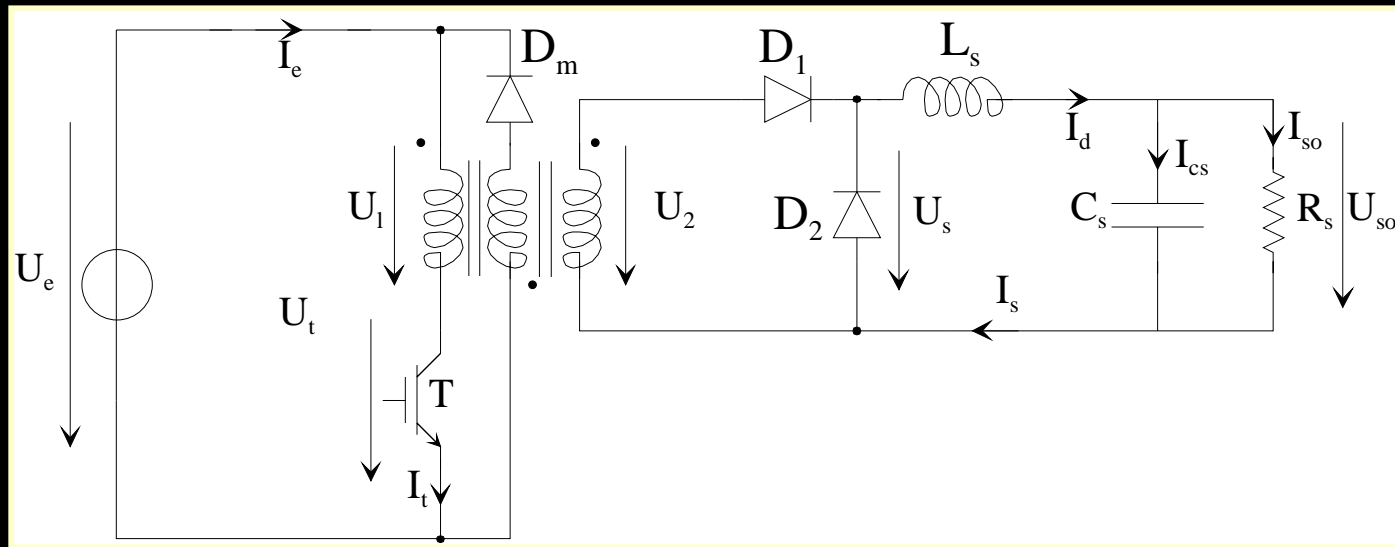

- Energy flows directly from the primary side to the secondary side of the transformer when the transistor is ON.
- A third winding is needed to control the magnetization current when the transistor is switched off.
- From the voltage  $U_s$  the behaviour is that one of a buck converter.

# DC/DC converters with transformers

- Forward

- Voltage and current waveforms

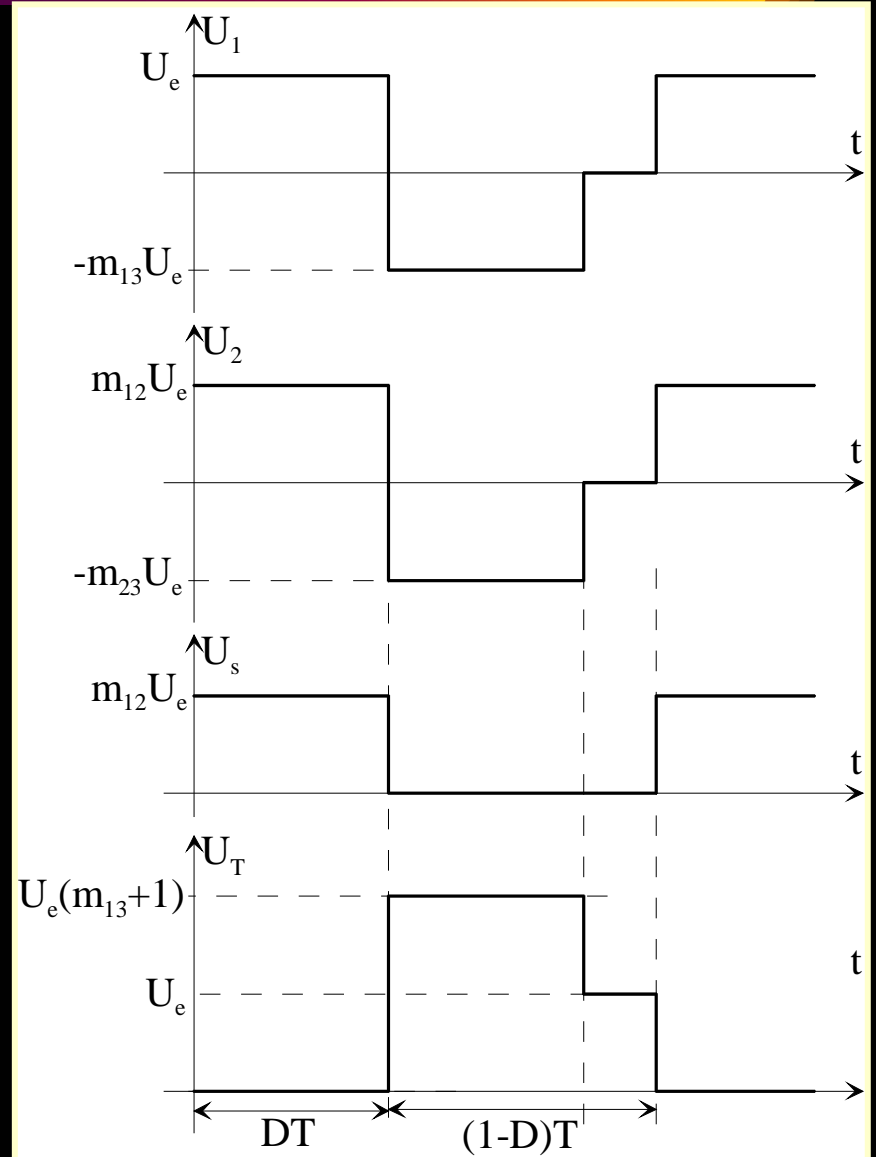
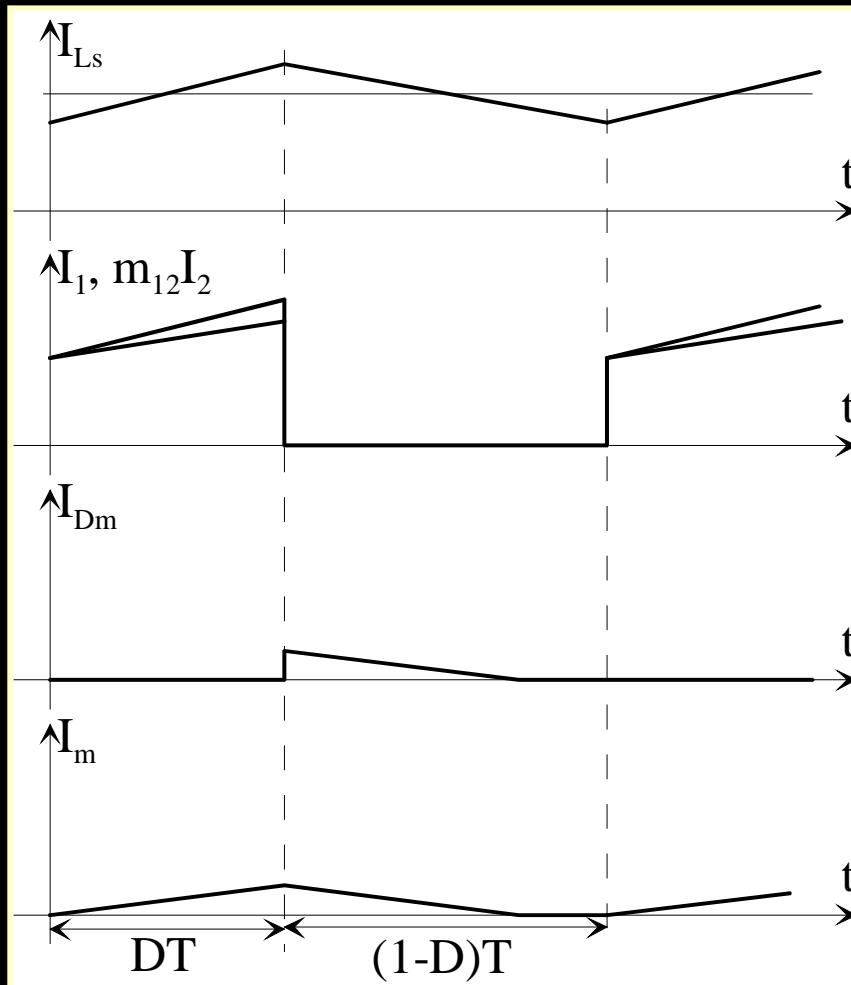

## DC/DC converters with transformers

- Forward
  - Voltage and current waveforms
    - When the transistor is ON:
      - ⇒ The secondary voltage and  $U_s$  are  $m_{12}U_e$
      - ⇒ The primary current is the sum of the secondary current (modulo the ratio  $m_{12}$ ) and the magnetization current.
    - When the transistor is switched off:
      - ⇒ Primary and secondary currents are 0
      - ⇒ The demagnetization circuit is ON
      - ⇒ Primary and secondary voltages are negative
      - ⇒ Transistor voltage is  $m_{13}U_e + U_e$
    - When the demagnetization is completed:
      - ⇒ Primary and secondary voltages and currents are 0 (free-wheeling mode)
    - Condition for a complete demagnetization of the transformer (before the conduction of the transistor)

$$D < \frac{m_{13}}{1 + m_{13}}$$

## DC/DC converters with transformers

- Forward
  - From the voltage  $U_s$ , the behaviour of the forward is close of the buck
    - Limit: leakage inductances, with conduction of both  $D_1$  and  $D_2$  during the commutations of the transistor
    - Output characteristics of identical the the Buck, where the only difference is the factor  $m_{12}$  applied to  $U_e$
    - Compared to the flyback, smaller transformer
    - Three windings are needed (more complex)
    - Leakage inductances need to be reduced as possible.

# DC/DC converters with transformers

- DC/AC/DC Converters:
  - Principle:
    - Input Rectifier + input filter : voltage source

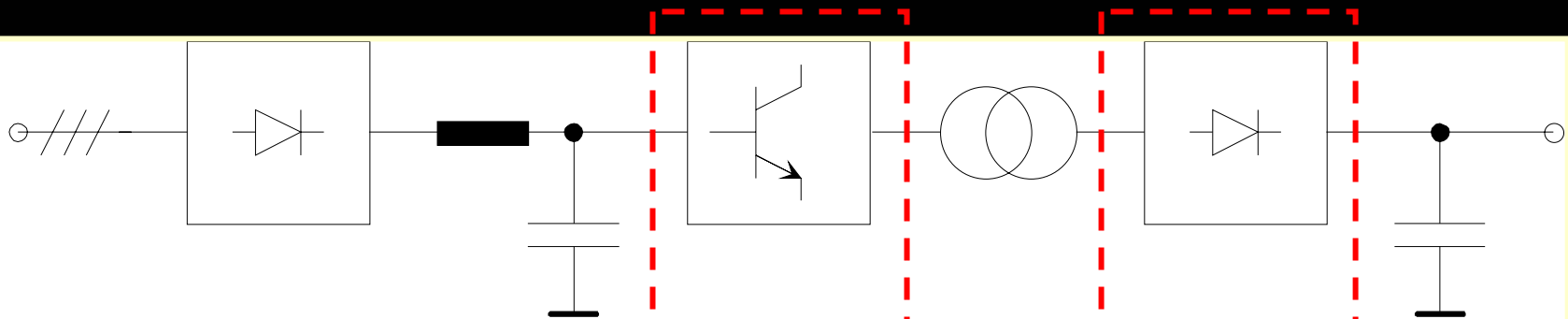

DC/AC  
converter

Rectifier

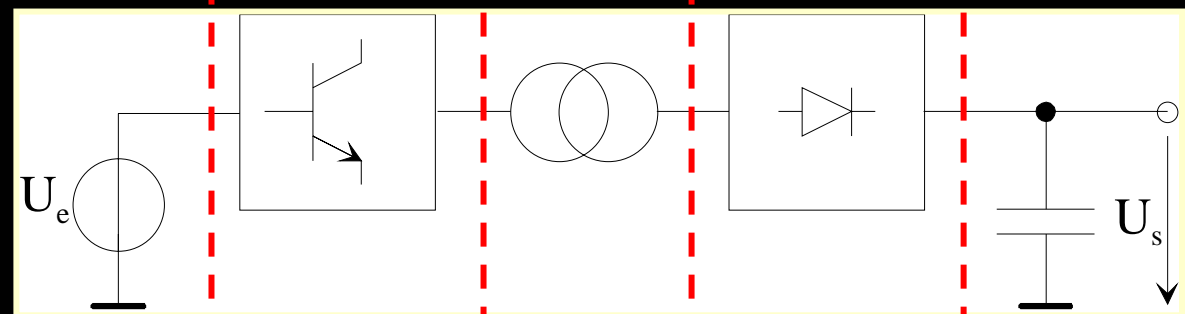

## DC/DC converters with transformers

- DC/AC/DC Converters:
  - Principle:
    - First stage: Voltage inverter
      - ⇒ Able to manage energy transfer between
        - a DC voltage source : from an input filter (C)
        - an AC current source : the primary side of a transformer
    - Second stage: medium frequency transformer
      - ⇒ Galvanic insulation, Voltage/current level adaptation
    - Third stage: rectifier
      - ⇒ Able to manage energy transfer between
        - An AC voltage source (secondary of the transformer. Leakage inductances?)
        - A DC current source
  - 1 quadrant converter:
    - Diodes for the rectifier
    - Output voltage level will be adjusted by the voltage inverter

## DC/DC converters with transformers

### DC/AC/DC Converters:

- H-bridge voltage inverter + full H-bridge diode rectifier

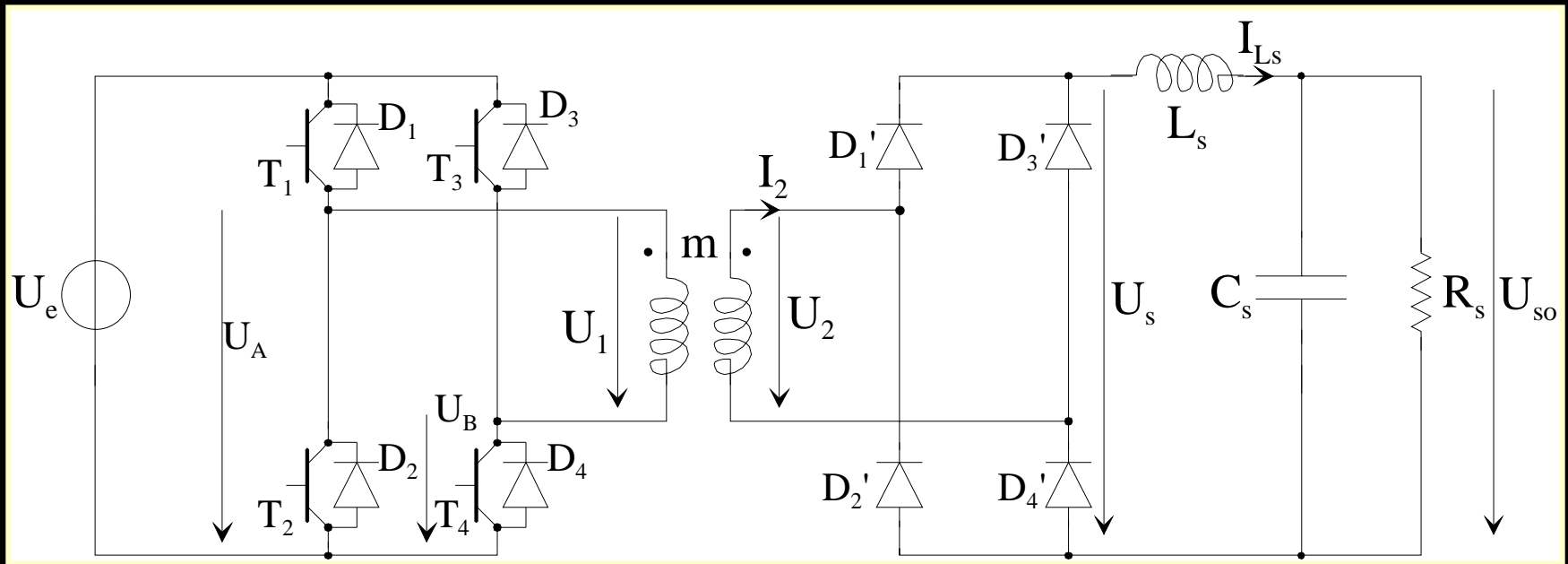

- Voltage inverter

- 2 switching cells:  $(T_1, D_1), (T_2, D_2)$  and  $(T_3, D_3), (T_4, D_4)$
- Each switching cell is controlled with the same switching frequency, duty cycle 50%
- The 2<sup>nd</sup> switching cell can be phase-shifted from the first one



## DC/DC converters with transformers

- DC/AC/DC Converters:
  - H-bridge voltage inverter + full H-bridge diode rectifier
    - The duty cycle  $D$  defines the time delay between the two switching cells
    - The Width of the positive and negative pulse varies from 0 to  $T/2$  when  $D$  varies from 0 to 1

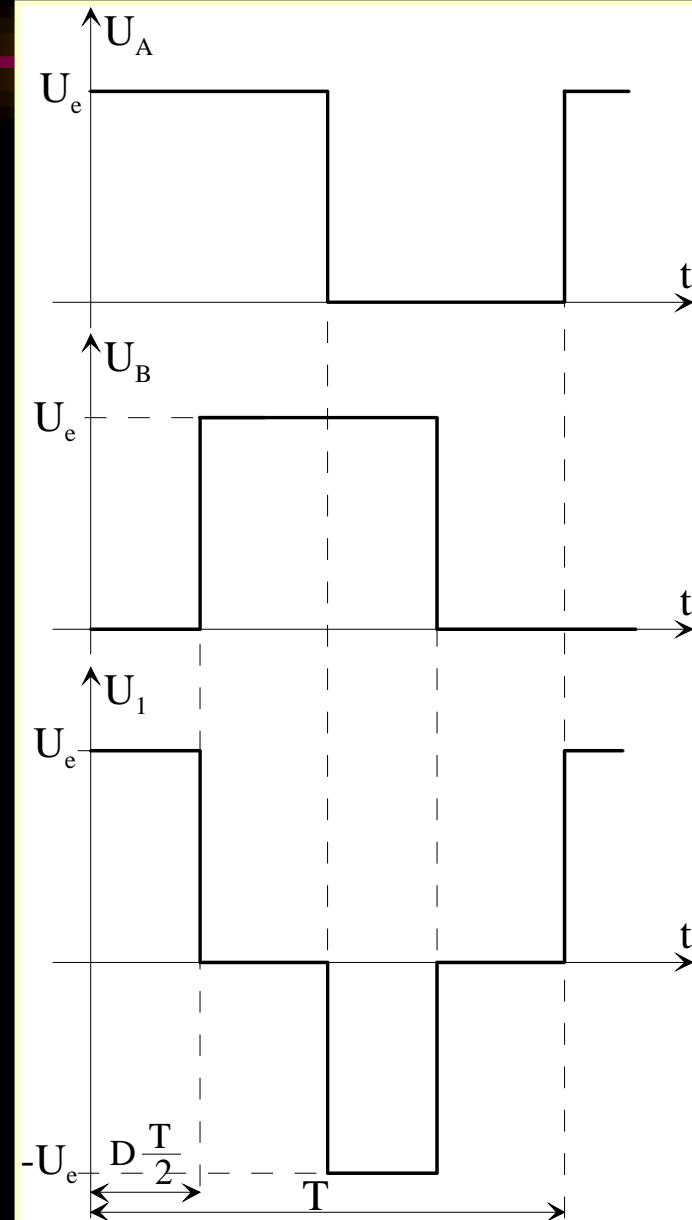
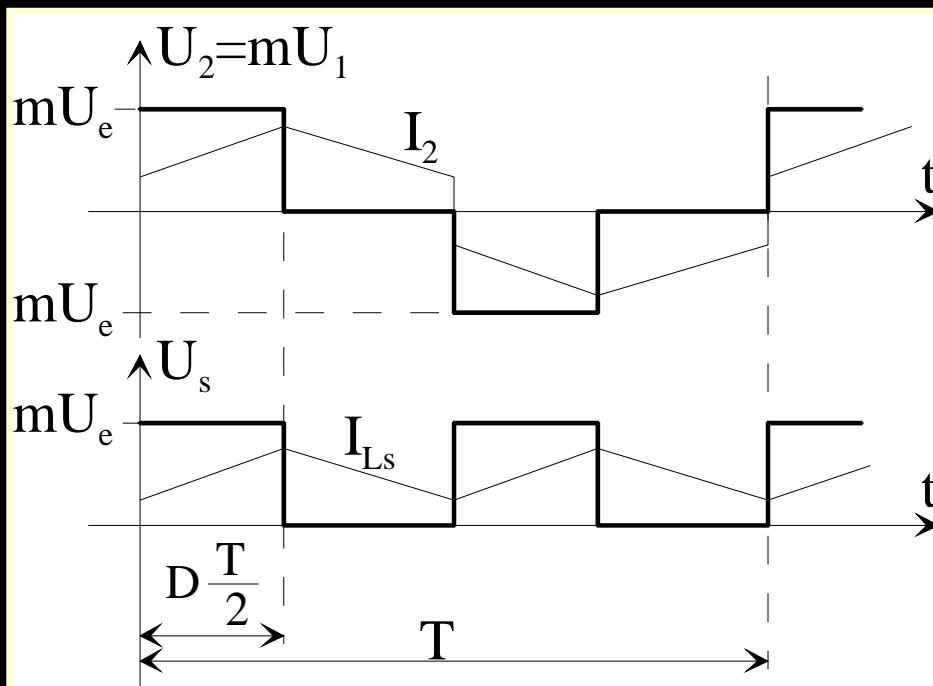

## DC/DC converters with transformers

- DC/AC/DC Converters:

- H-bridge voltage inverter + full H-bridge diode rectifier

- From the voltage  $U_s$ , the behaviour is close to that one of a Buck Converter:

⇒ Averaged output voltage

$$U_{so} = U_s = mDU_e$$

⇒ Current ripple in  $L_s$ :

$$\Delta I_{Ls} = \frac{mU_e}{2L_s F} (1 - D) D$$

⇒ Averaged output current:

- Defines mainly the magnitude of the AC current in the secondary side of the transformer

## DC/DC converters with transformers

- DC/AC/DC Converters:
  - H-bridge voltage inverter + full H-bridge diode rectifier
    - Transformer Primary side currents

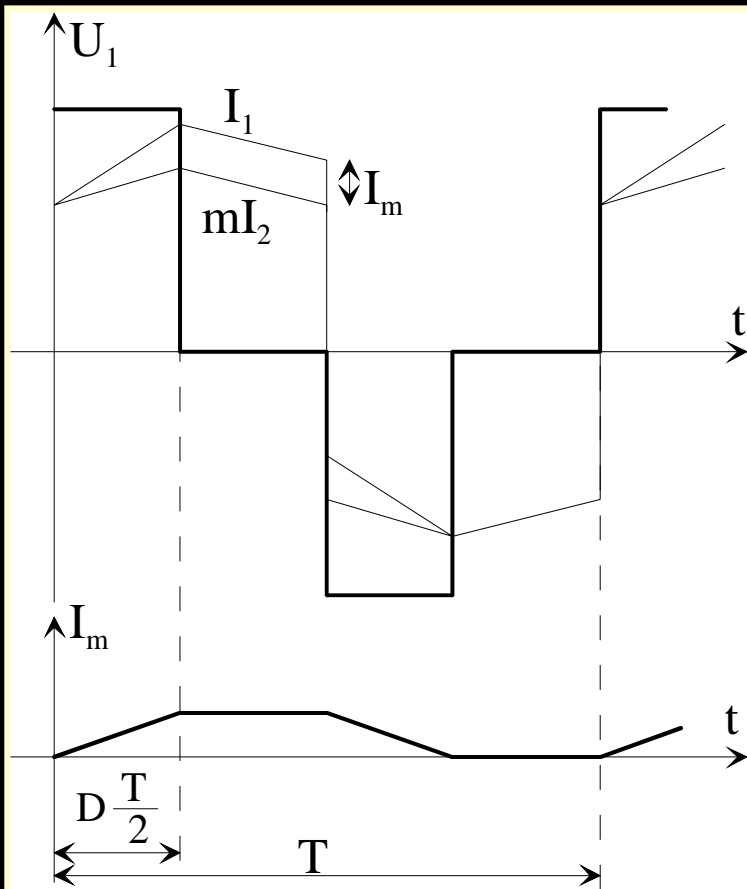

- The mean value of  $U_1$  must be 0 to control the magnetization current of the transformer
  - The width of positive and negative pulse must be identical in one switching period

## DC/DC converters with transformers

- DC/AC/DC Converters:
  - H-bridge voltage inverter + diode rectifier

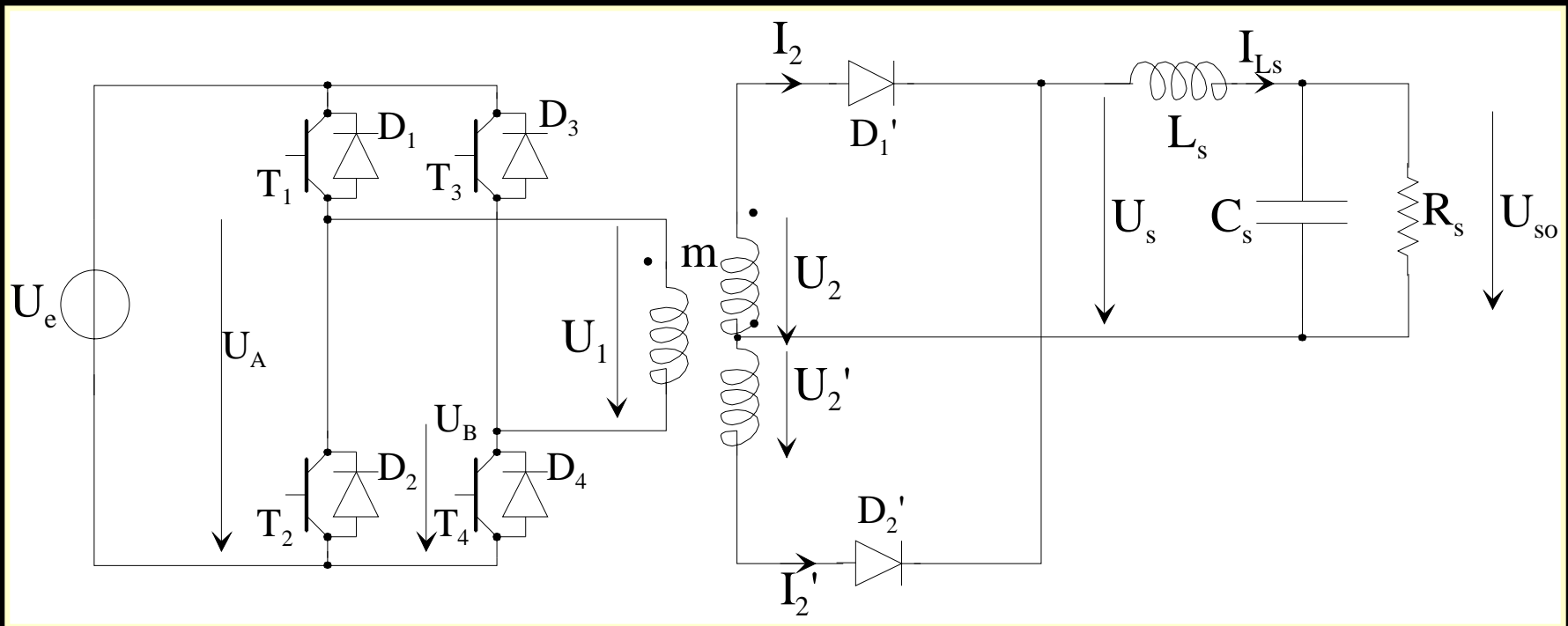

- Equivalent solution compared to the full-bridge rectifier

## DC/DC converters with transformers

- DC/AC/DC Converters:
  - H-bridge voltage inverter + diode rectifier:
    - Efficiency:
      - ⇒ Conduction losses
      - ⇒ Switching losses:
        - Can be reduced if ZVT (Zero Voltage transition) is possible
        - Can be reduced if ZCS (Zero Current switching) is possible
    - Switching process must be analyzed to identify:
      - ⇒ If natural ZVT and/or ZCS occur
      - ⇒ The devices to add in order to allow ZVT and ZCS

## DC/DC converters with transformers

- DC/AC/DC Converters:
  - H-bridge voltage inverter + diode rectifier:
    - Taking into account leakage inductances of the transformer
  - switching cells  $(T_3, D_3), (T_4, D_4)$ :
    - ZVT thanks to the free-wheeling phase
  - switching cells  $(T_1, D_1), (T_2, D_2)$ :
    - ZVT only due to the leakage inductances of the transformer

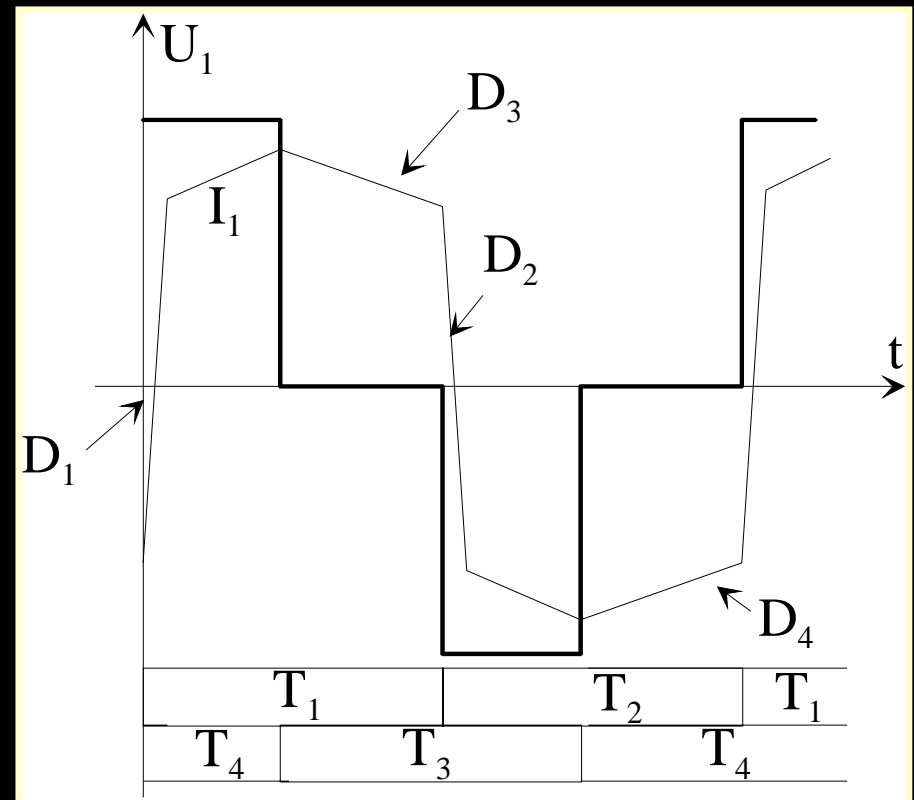

## DC/DC converters with transformers

- DC/AC/DC Converters:
  - H-bridge voltage inverter + diode rectifier:
    - Adding a dc blocking capacitor and a saturable inductor to allow ZCS conditions

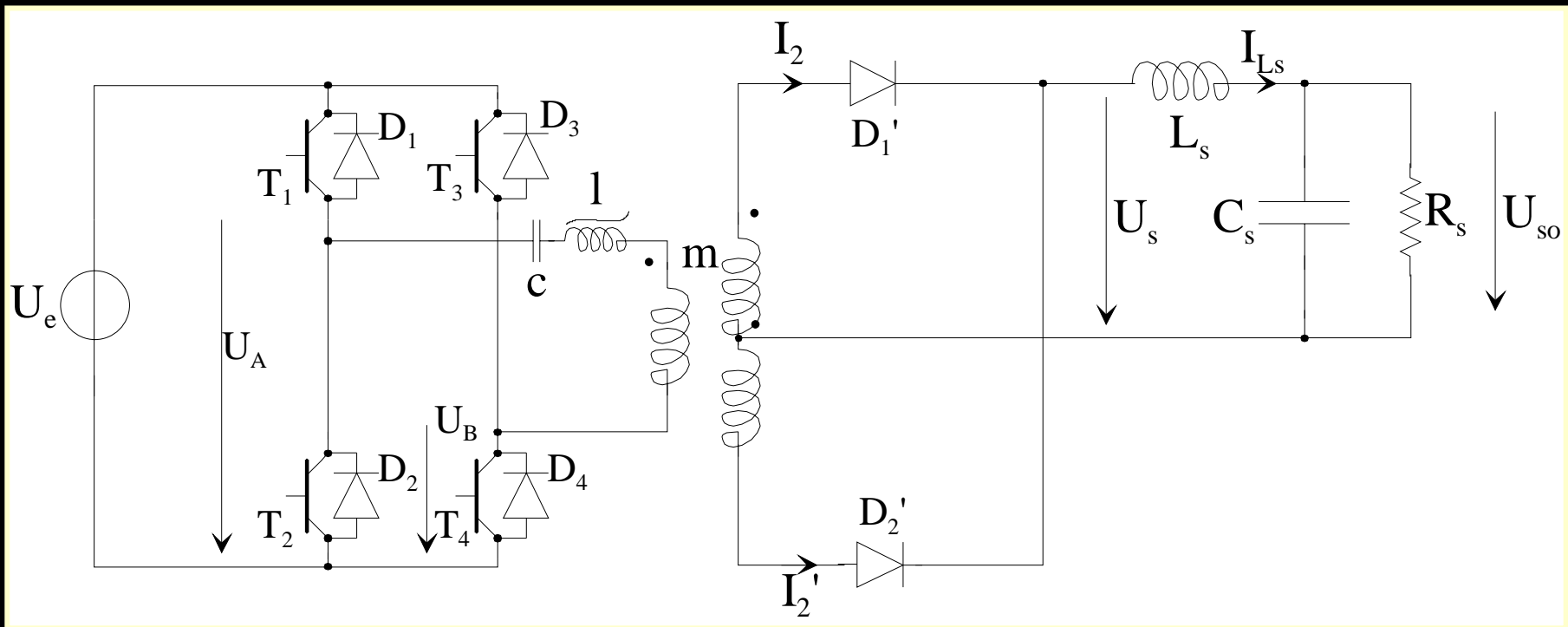

## DC/DC converters with transformers

- DC/AC/DC Converters:
  - H-bridge voltage inverter + diode rectifier:
    - Adding a dc blocking capacitor and a saturable inductor to allow ZCS conditions
  - switching cells  $(T_3, D_3), (T_4, D_4)$  :
    - Each Turn ON of a transistor is made with ZCS and ZVS conditions
    - Each turn OFF of a transistor, capacitors are needed to limit the  $du/dt$
  - switching cells  $(T_1, D_1), (T_2, D_2)$  :
    - Each Turn ON of a transistor is made with ZCS conditions
    - Each turn OFF of a transistor is also made with ZCS conditions

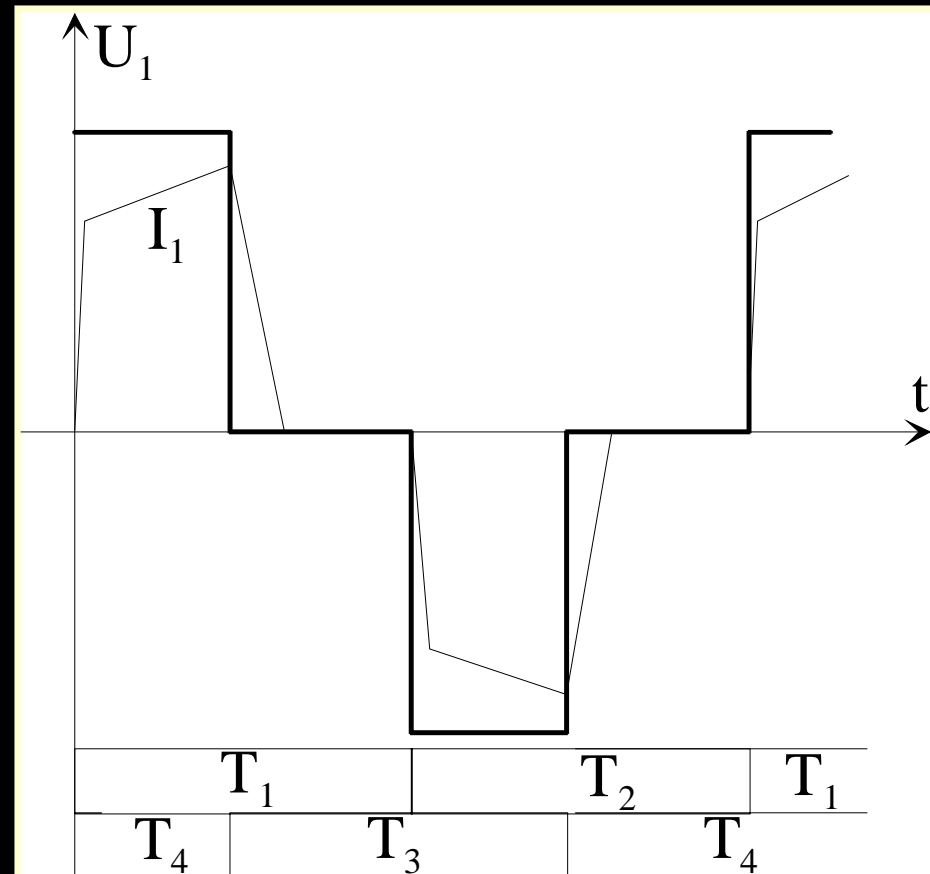



## DC/DC converters with transformers

- DC/AC/DC Converters:
  - H-bridge voltage inverter + diode rectifier:
    - Adding a dc blocking capacitor and a saturable inductor to allow ZCS conditions
      - ⇒ Reduction of switching losses,
      - ⇒ Components such as IGBTs can be used
      - ⇒ High voltage, high power applications.