

# Superconducting magnets for Accelerators

*Martin N Wilson (Rutherford Lab ⇒ Oxford Instruments ⇒ CERN ⇒ consultant)*

## Outline

- why bother with superconductivity?
- properties of superconductors: critical field, temperature & current density
- magnetic fields and how to create them
- load lines, training and how to cure it
- screening currents and the critical state model
- fine filaments, composite wires & cables
- magnetization, field errors & ac losses
- quenching and protection
- hardware
- where to get more info

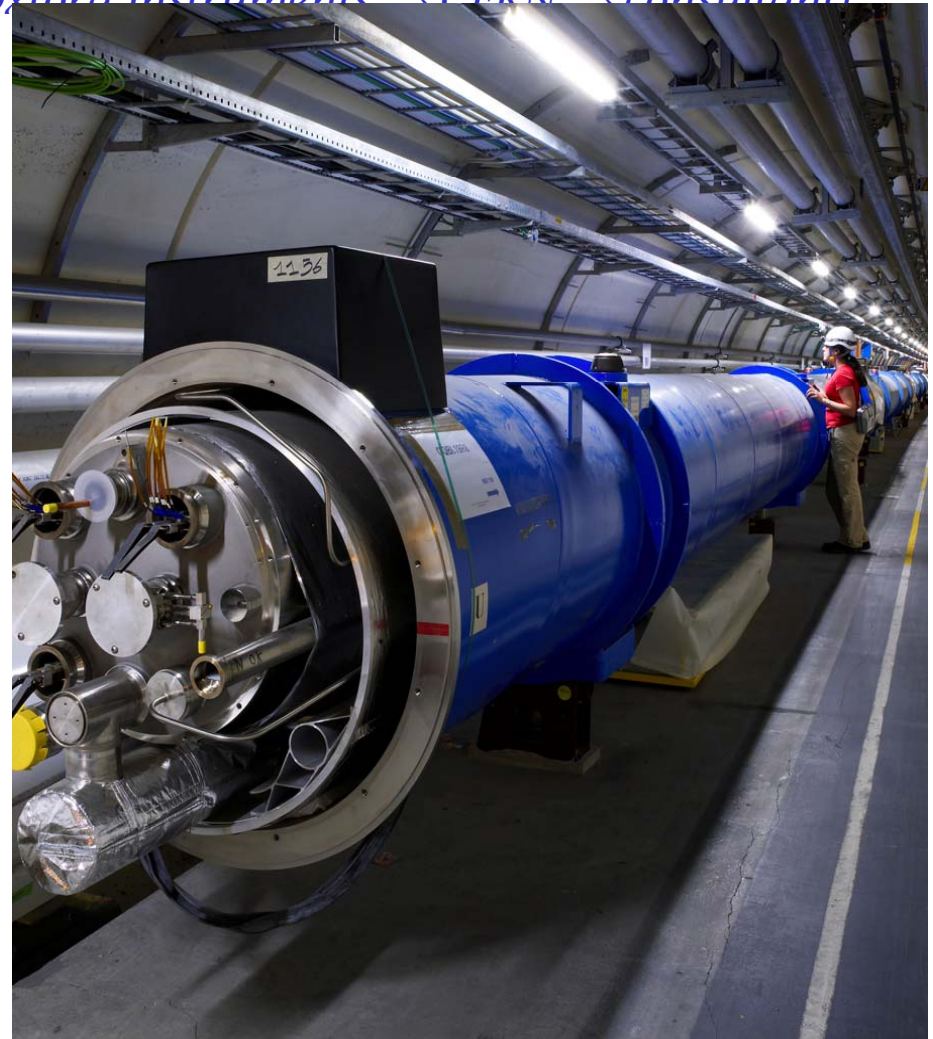

# *Superconducting magnets for Accelerators*

## *Who needs superconductivity anyway?*

### *Abolish Ohm's Law!*

- no power consumption  
(although do need refrigeration power)
- ampere turns are cheap, so don't need iron  $\Rightarrow$  higher fields  
(although often use it for shielding)
- high current density  $\Rightarrow$  compact windings, high gradients

### *Consequences*

- lower power bills
- higher magnetic fields mean reduced bend radius
  - $\Rightarrow$  smaller rings
  - $\Rightarrow$  reduced capital cost
  - $\Rightarrow$  new technical possibilities  
(eg muon collider)
- higher quadrupole gradients
  - $\Rightarrow$  higher luminosity



# The critical surface of niobium titanium

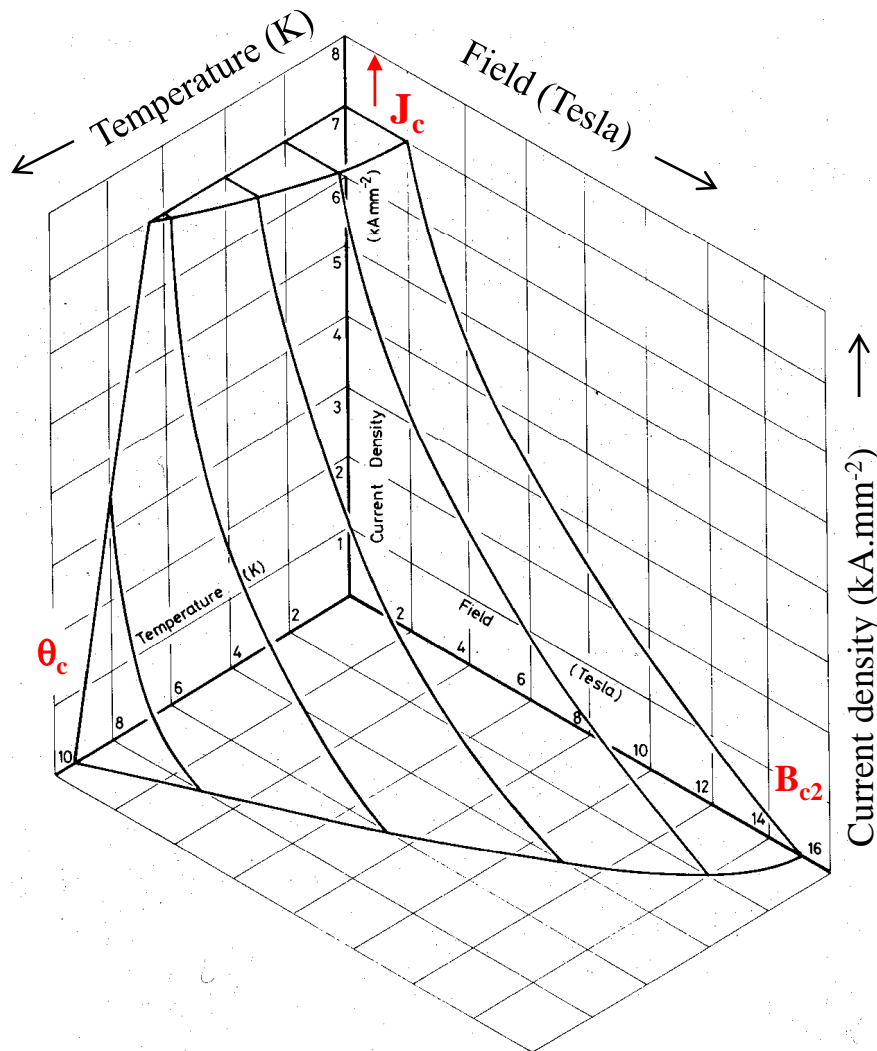

- Niobium titanium **NbTi** is the standard ‘work horse’ of the superconducting magnet business
- it is a ductile alloy
- picture shows the **critical surface**, which is the boundary between superconductivity and normal resistivity in 3 dimensional space
- superconductivity prevails everywhere below the surface, resistance everywhere above it
- we define an upper critical field  $B_{c2}$  (at zero temperature and current) and critical temperature  $\theta_c$  (at zero field and current) which are characteristic of the alloy composition
- critical current density  $J_c(B, \theta)$  depends on processing

# The critical line at 4.2K

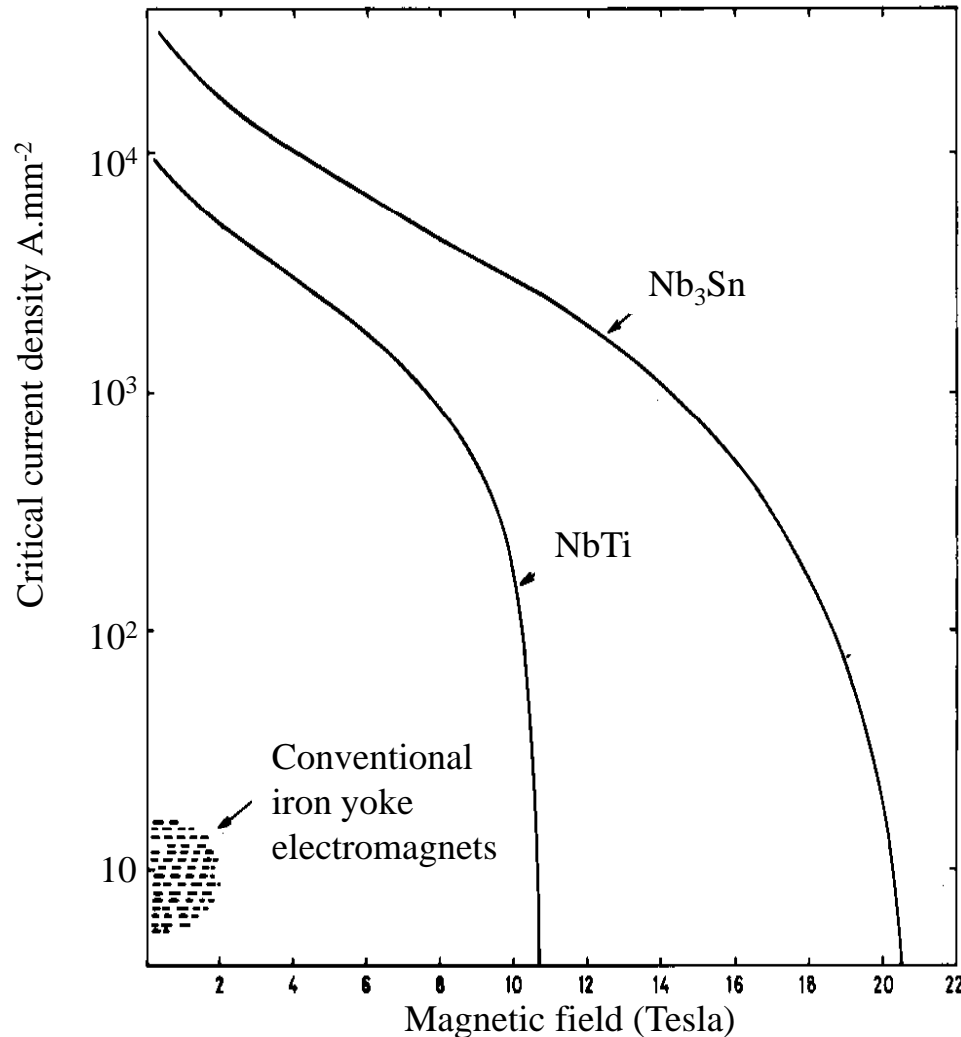

- because magnets usually work in boiling liquid helium, the critical surface is often represented by a curve of current versus field at 4.2K
- niobium tin Nb<sub>3</sub>Sn has a much higher performance in terms of critical current field and temperature than NbTi
- but it is brittle intermetallic compound with poor mechanical properties
- note that both the field and current density of both superconductors are way above the capability of conventional electromagnets

# Critical field & temperature of metallic superconductors

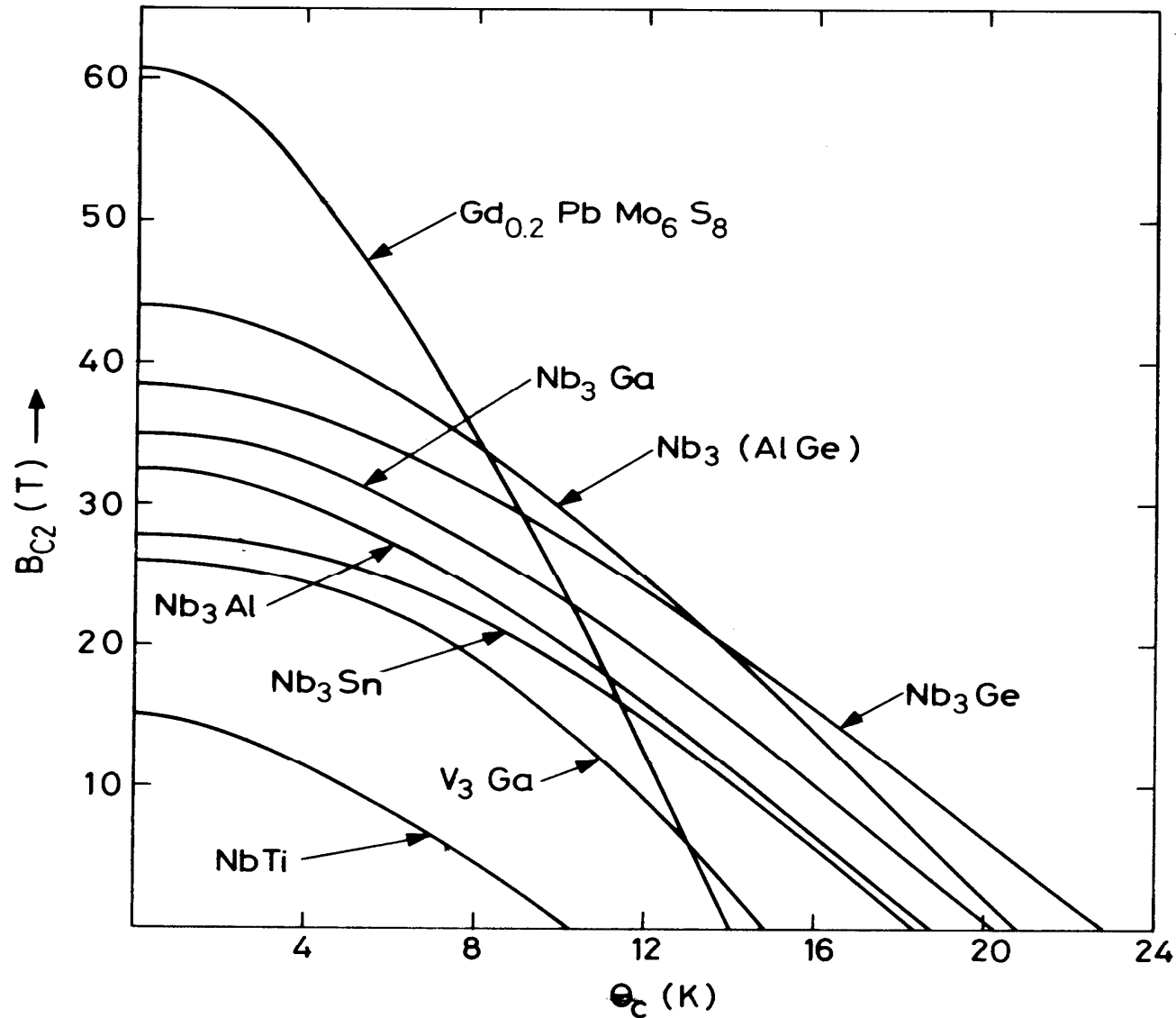

Note: of all the metallic superconductors, only NbTi is ductile.

All the rest are brittle intermetallic compounds

# Critical field & temperature of metallic superconductors

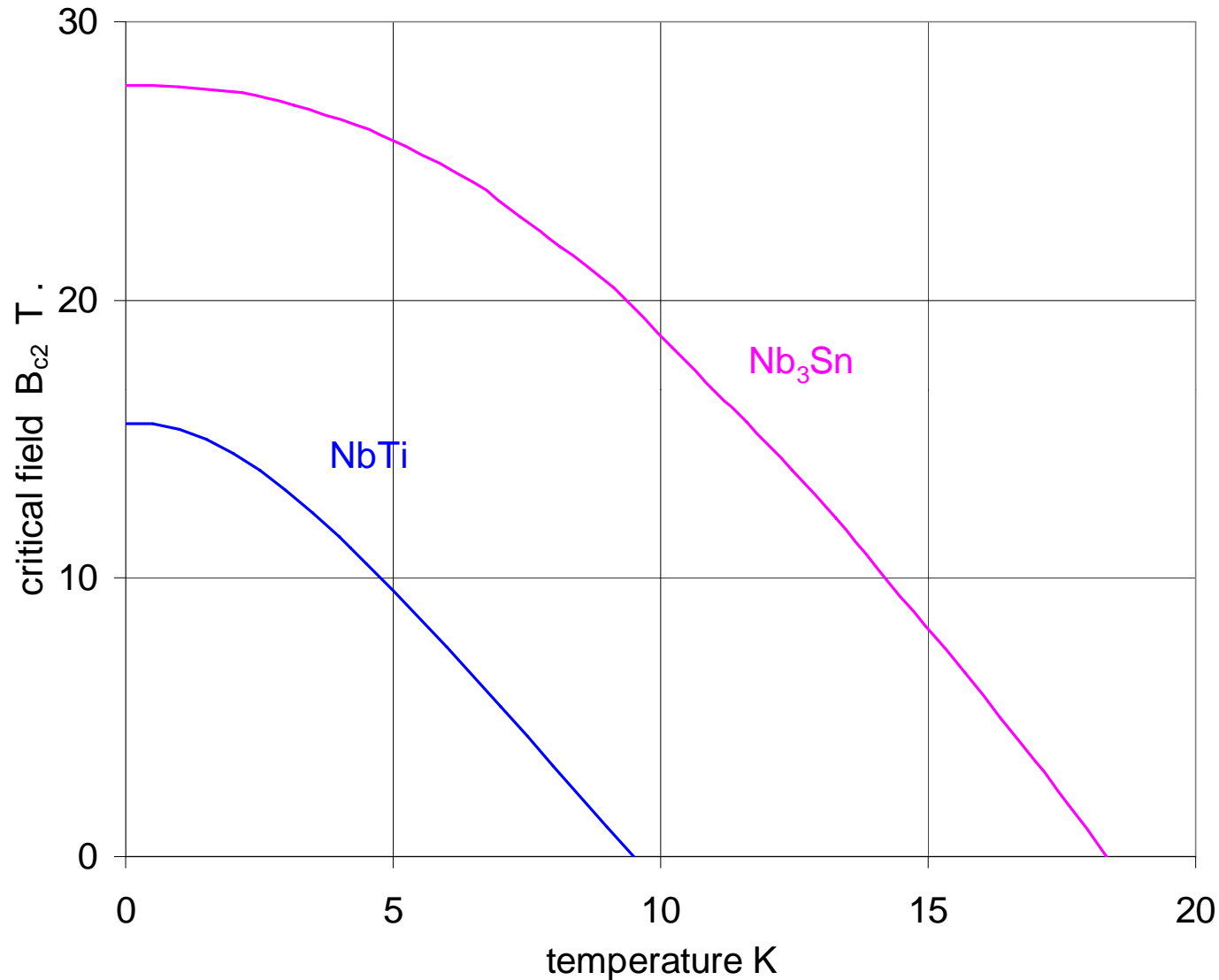

To date, all superconducting accelerators have used NbTi.

Of the intermetallics, only Nb<sub>3</sub>Sn has found significant use in magnets

# High temperature superconductors

1987 Bednortz  
and Muller

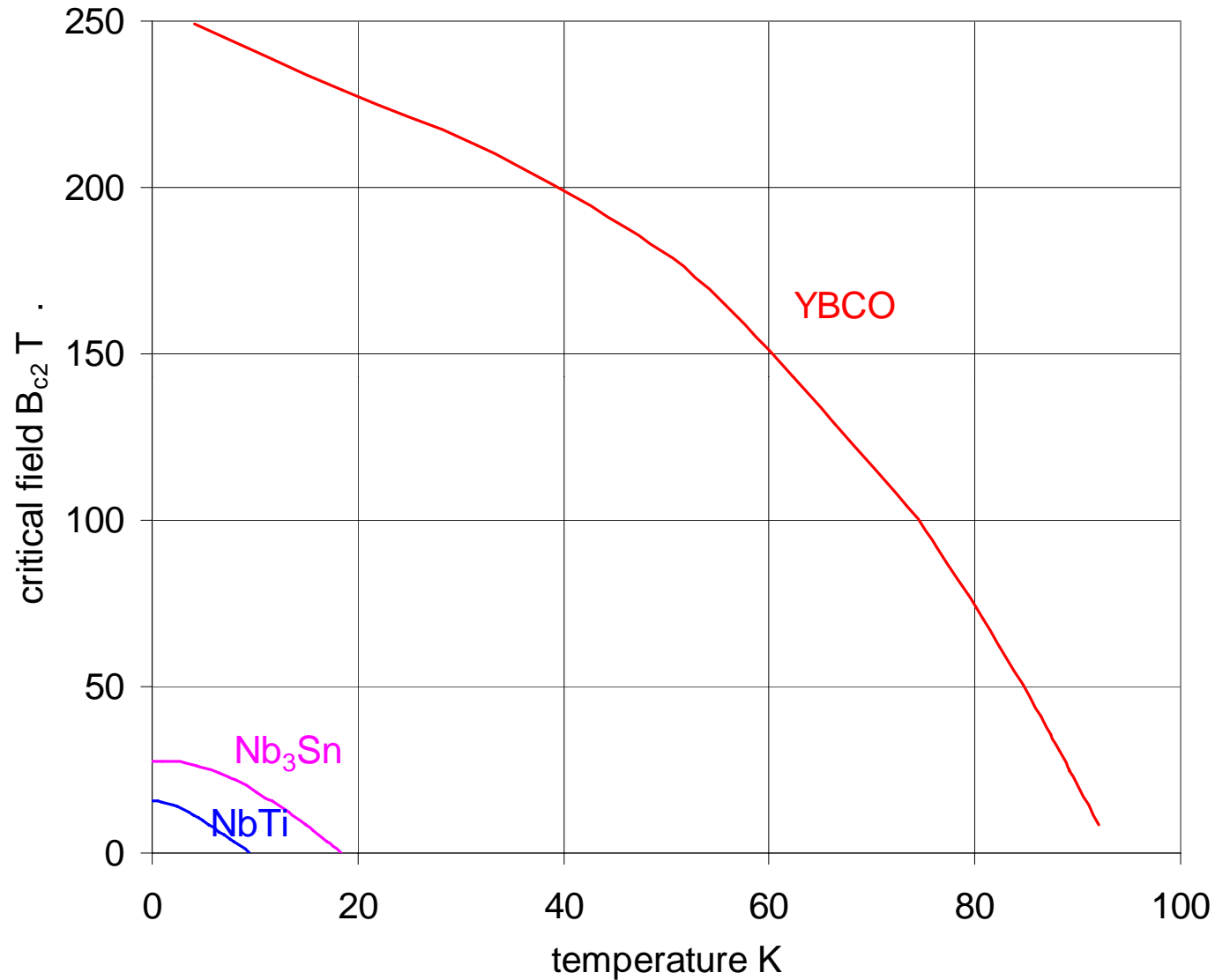

High critical  
temperature also  
brings high  
critical field

Yttrium Barium  
Copper Oxide  
 $YBa_2Cu_3O_7$

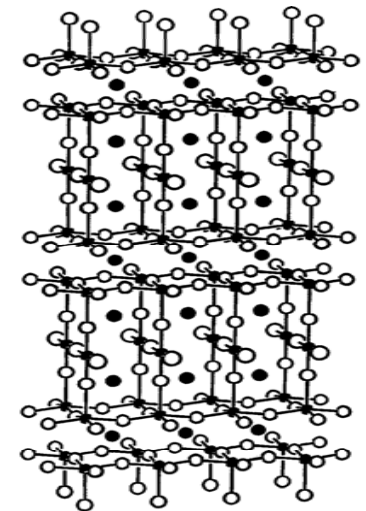



# High temperature superconductors

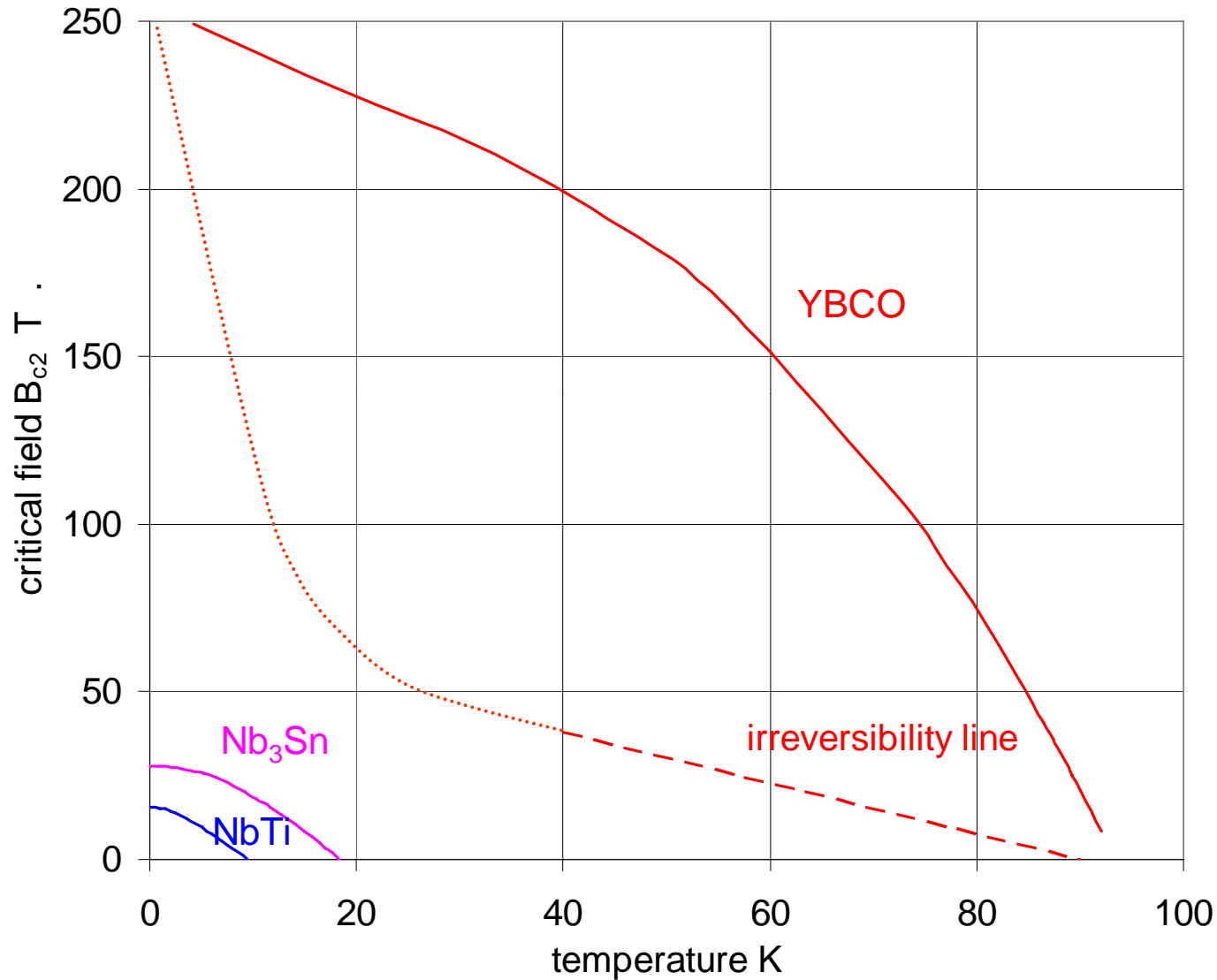

Unfortunately we only get superconducting current carrying below the irreversibility field

Yttrium Barium Copper Oxide  
 $\text{YBa}_2\text{Cu}_3\text{O}_7$

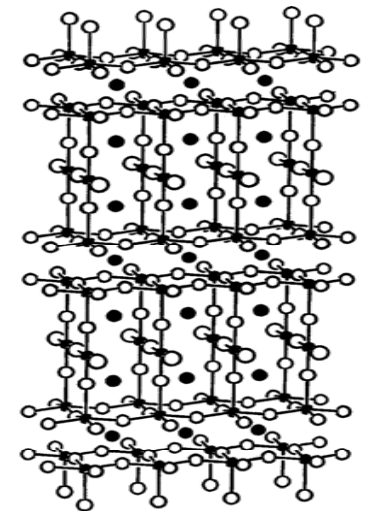



# High temperature superconductors

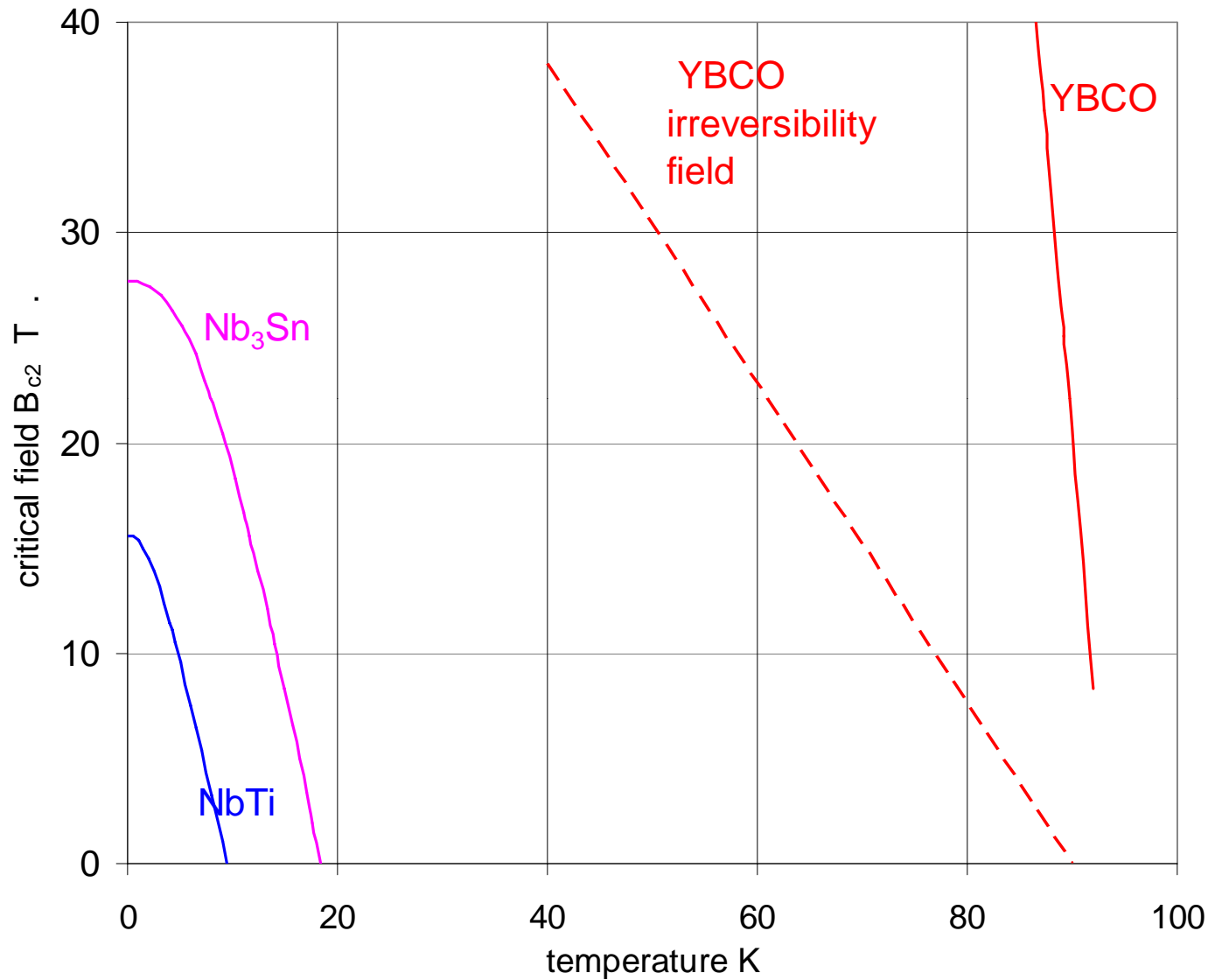

Yttrium Barium  
Copper Oxide  
 $\text{YBa}_2\text{Cu}_3\text{O}_7$

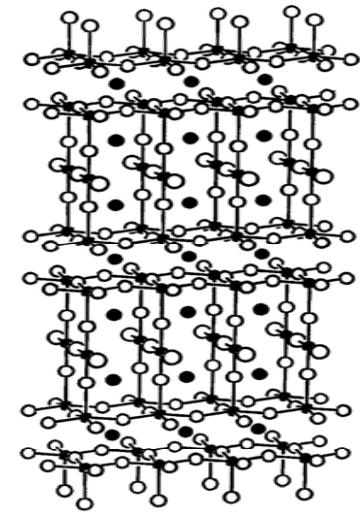

# High temperature superconductors

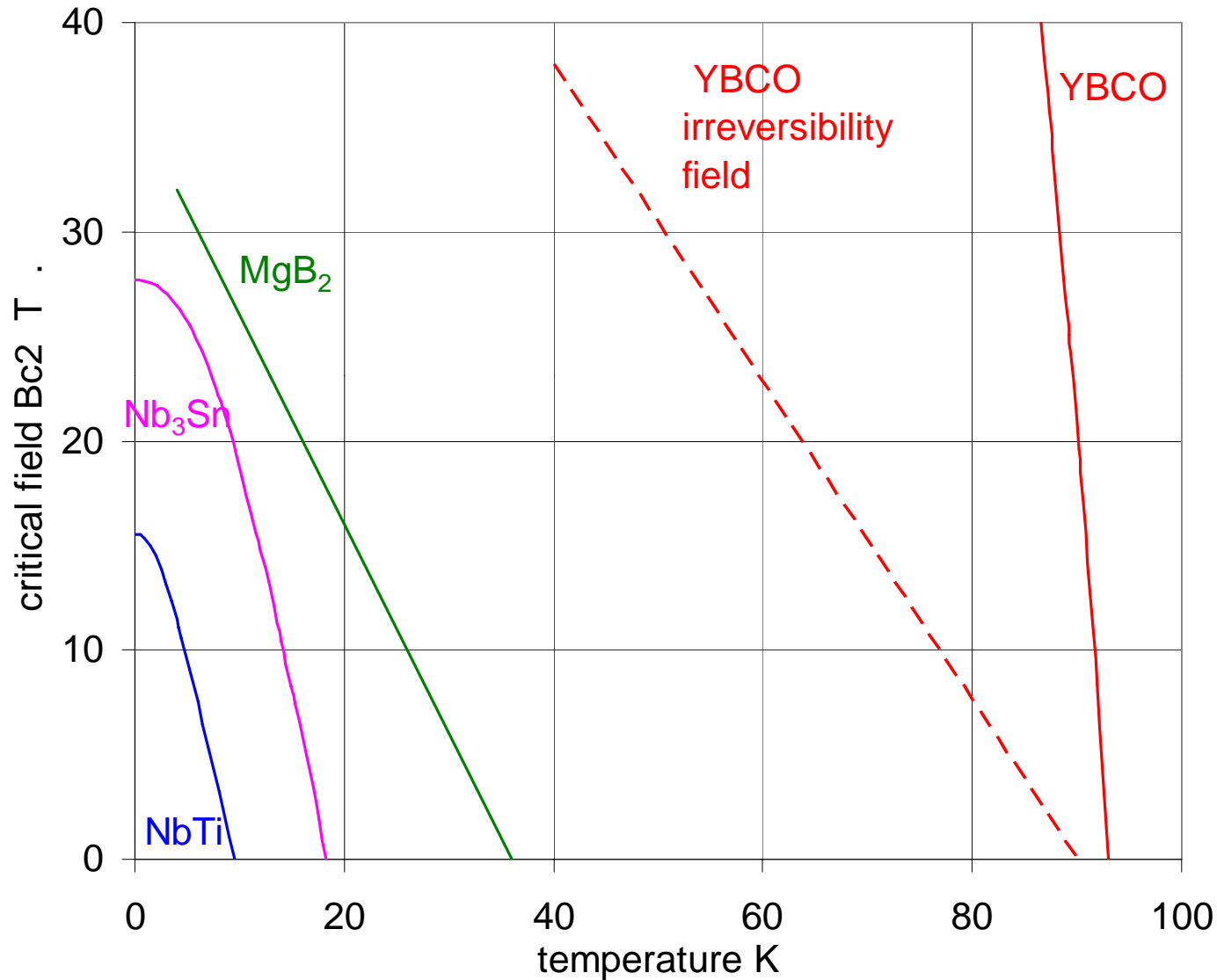

More recently magnesium diboride MgB<sub>2</sub> offers moderately high temperature in a simpler cheaper material

# High temperature superconductors

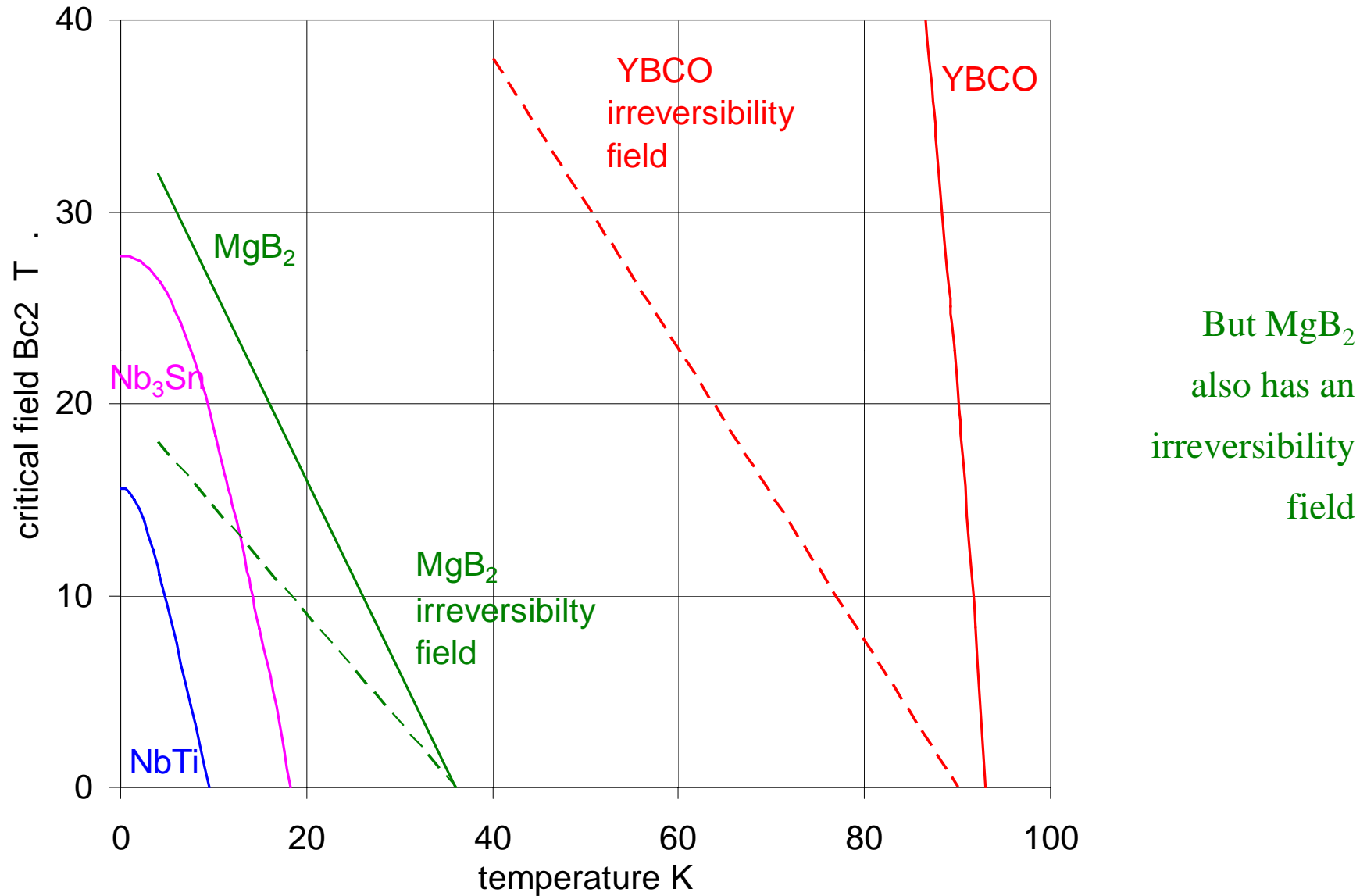

# High temperature superconductors

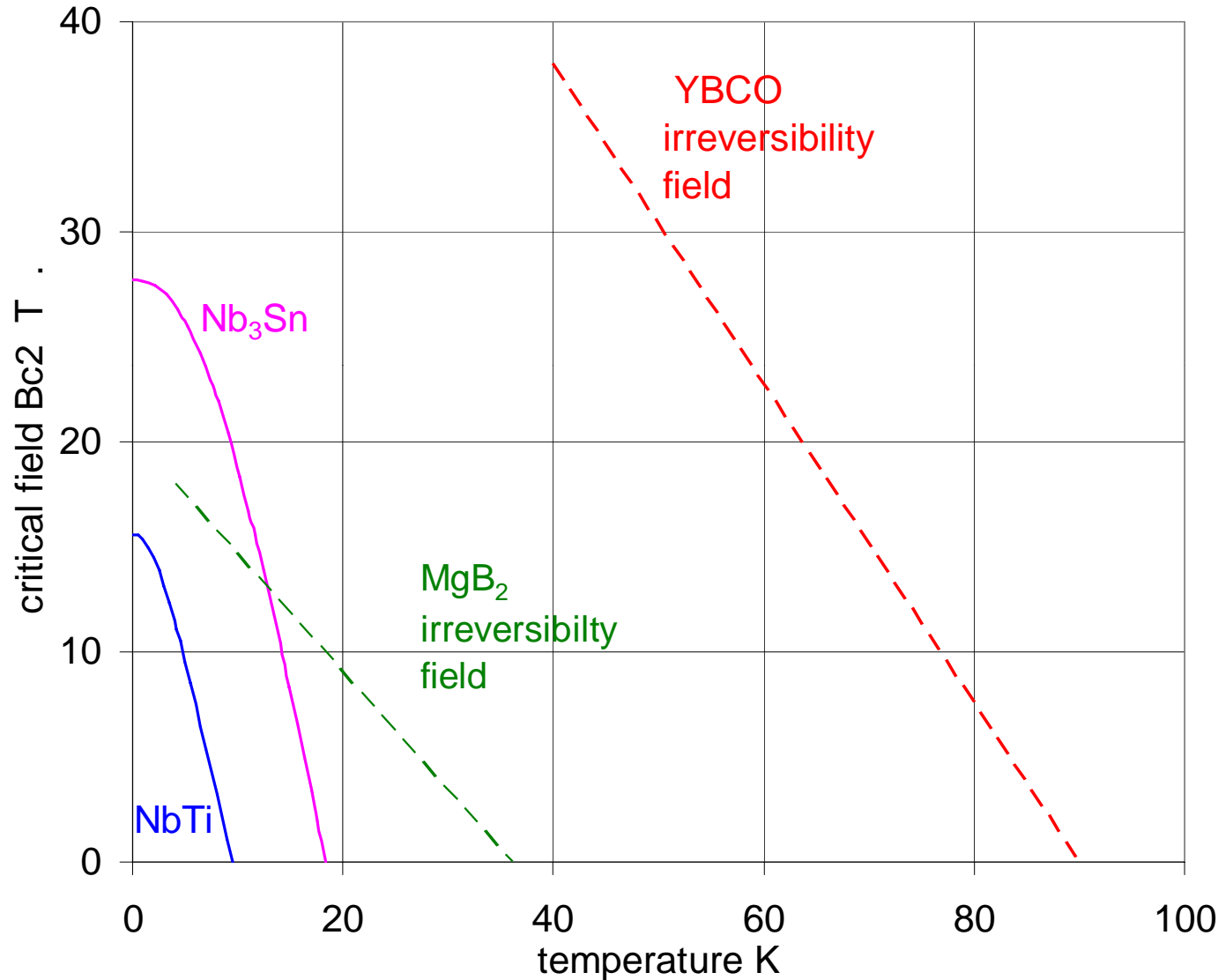

So here's the parameter space for future magnets

Critical current density  $J_c$  depends on skilful processing of the material

# Filamentary composite wires

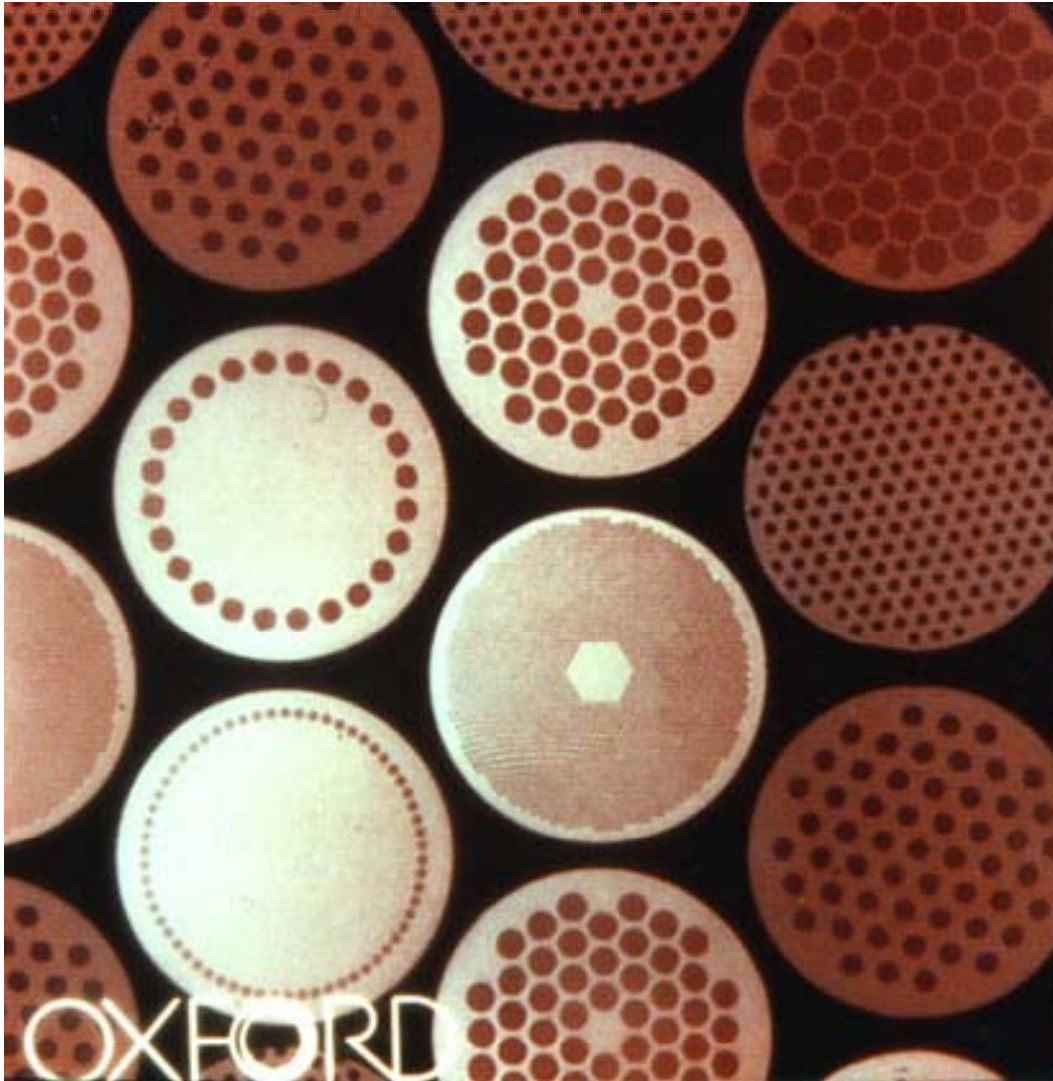

- for reasons that will be described later, superconducting materials are always used in combination with a good normal conductor such as copper
- to ensure intimate mixing between the two, the superconductor is made in the form of fine filaments embedded in a matrix of copper
- typical dimensions are:
  - wire diameter = 0.3 - 1.0mm
  - filament diameter = 5 - 50 $\mu$ m
- for electromagnetic reasons, the composite wires are twisted so that the filaments look like a rope

# Fields and ways to create them: conventional

- iron yoke reduces magnetic reluctance
  - ⇒ reduces ampere turns required
  - ⇒ reduces power consumption
- iron guides and shapes the field

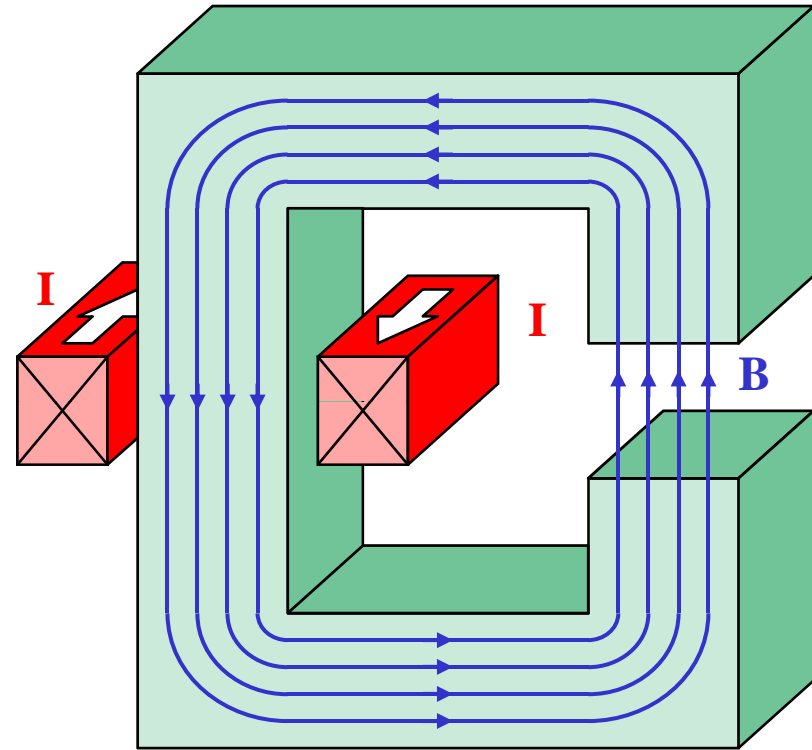

*Iron electromagnet  
– for accelerator, HEP experiment  
transformer, motor, generator, etc*

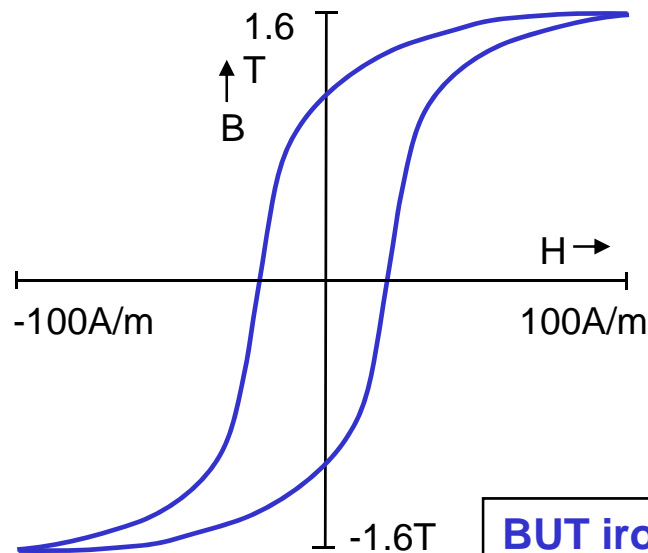



# Fields and ways to create them: superconducting dipoles

simplest winding  
uses racetrack  
coils

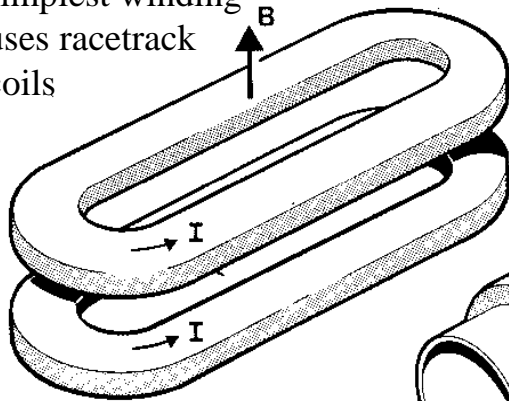

'saddle' coils make  
better field  
shapes

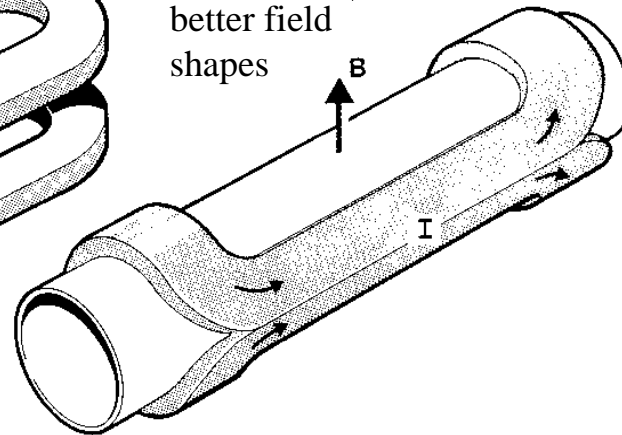

- some iron - but field shape is set mainly by the winding
- used when the long dimension is transverse to the field, eg accelerator magnets
- known as *dipole* magnets (because the iron version has 2 poles)

special winding cross  
sections for good  
uniformity

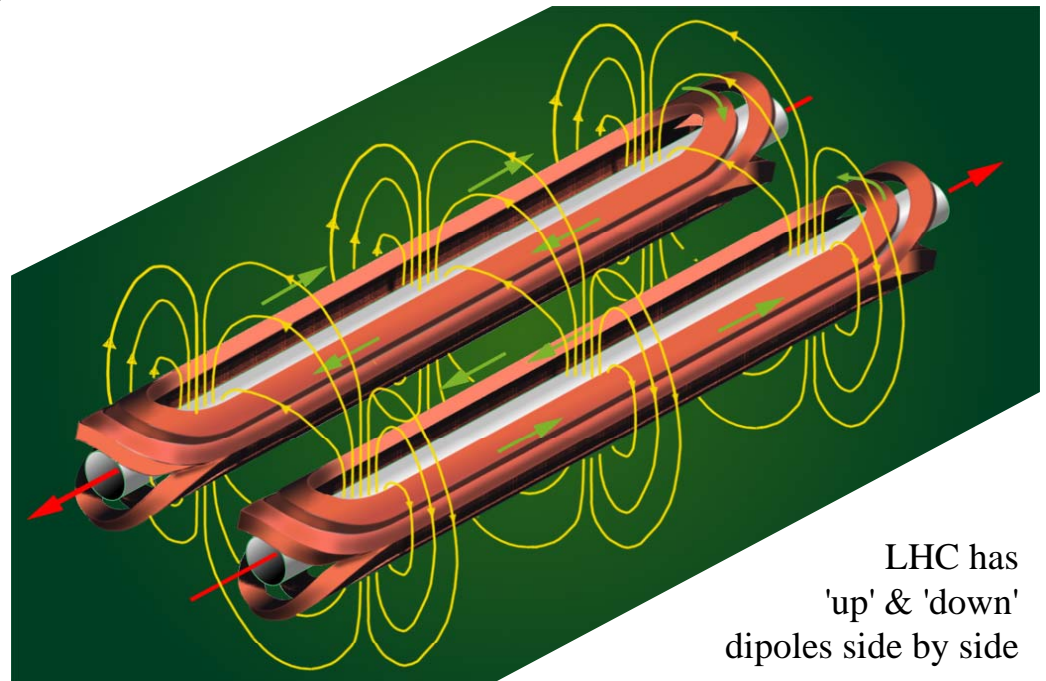
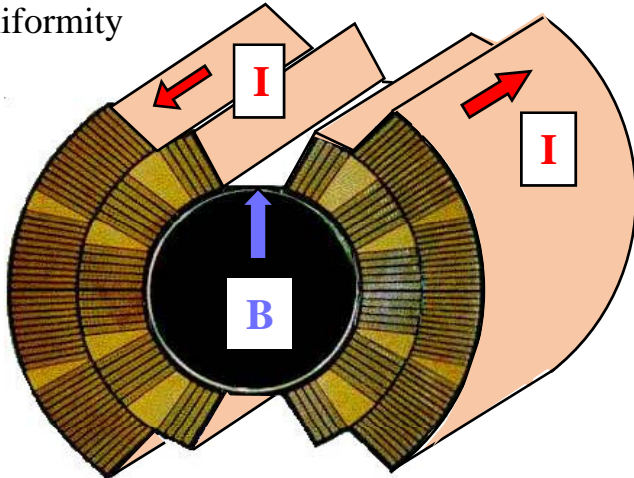

LHC has  
'up' & 'down'  
dipoles side by side



# Dipole field from overlapping cylinders

Ampere's law for the field inside a cylinder carrying uniform current density

$$\oint B \cdot ds = 2\pi r B = \mu_0 I = \mu_0 \pi r^2 J \quad B = \frac{\mu_0 J r}{2}$$

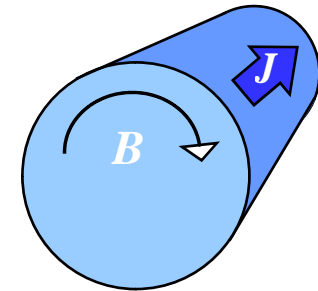

- two cylinders with opposite currents
- push them together
- where they overlap, currents cancel out
- zero current  $\Rightarrow$  the aperture
- fields in the aperture:

$$B_y = \frac{\mu_0 J}{2} (-r_1 \cos \theta_1 + r_2 \cos \theta_2) = \frac{-\mu_0 J t}{2}$$

$$B_x = \frac{\mu_0 J}{2} (-r_1 \sin \theta_1 + r_2 \sin \theta_2) = 0$$

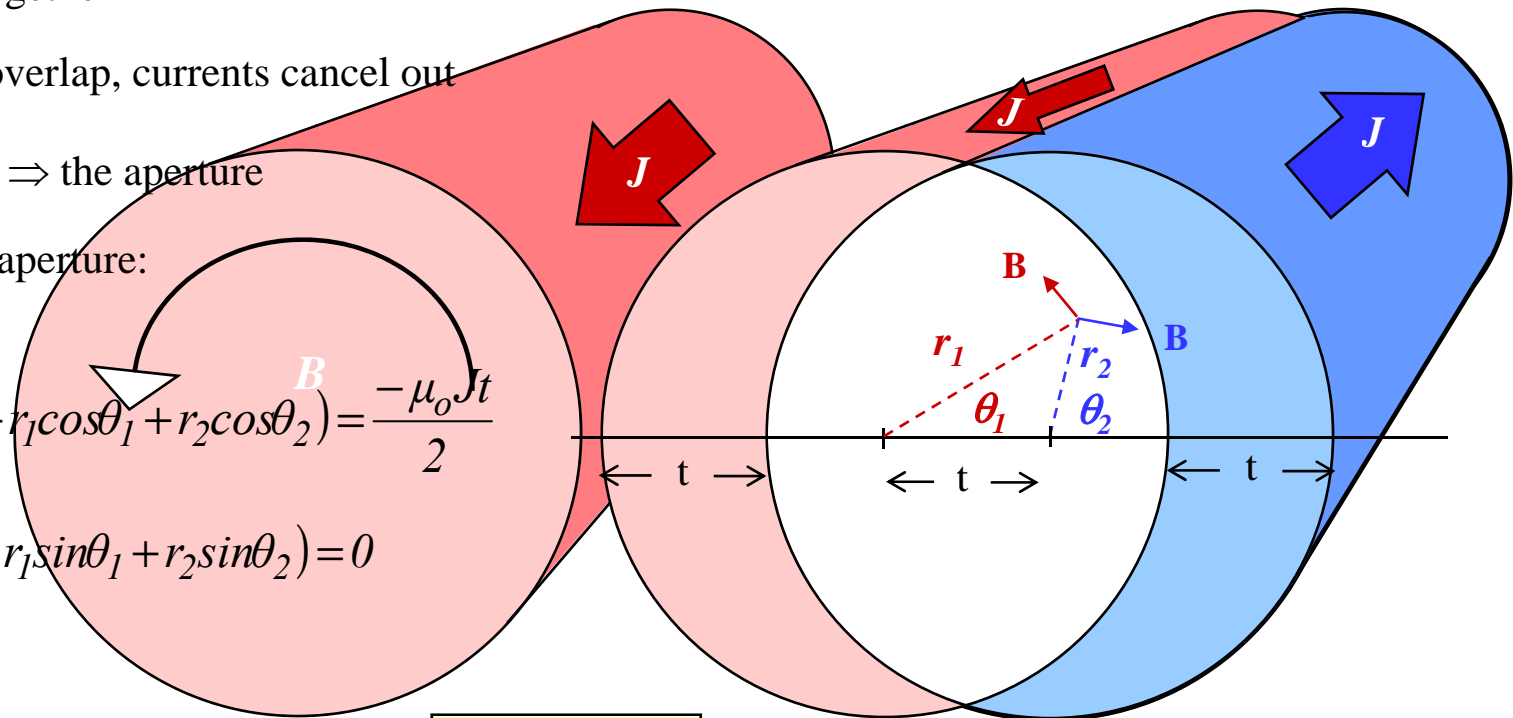

- thus the two overlapping cylinders give a perfect dipole field

$$B_y = \frac{-\mu_0 J_e t}{2}$$

# Dipole Magnets

- made from superconducting cable
- winding must have the right cross section
- also need to shape the end turns

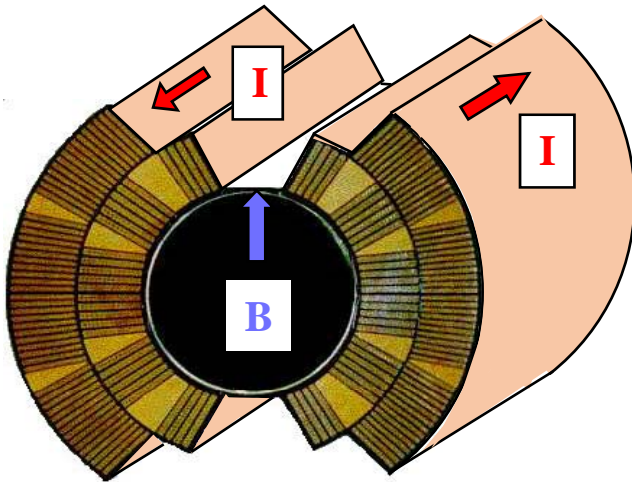



# Fields and ways to create them: superconducting quadrupoles

- gradient fields produce focussing
- quadrupole windings

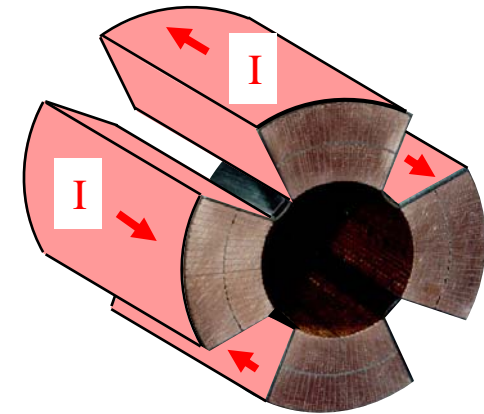
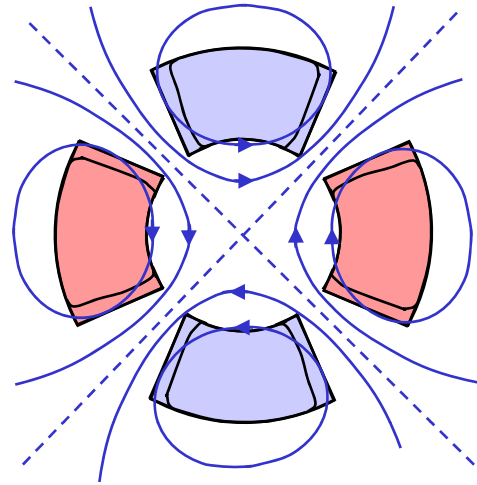
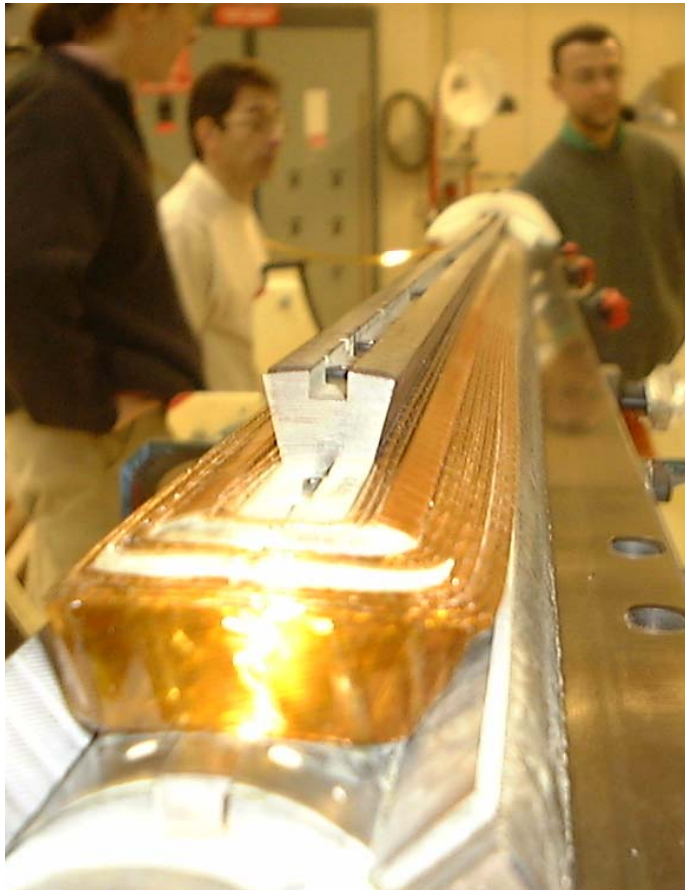

$$B_x = ky$$

$$B_y = kx$$

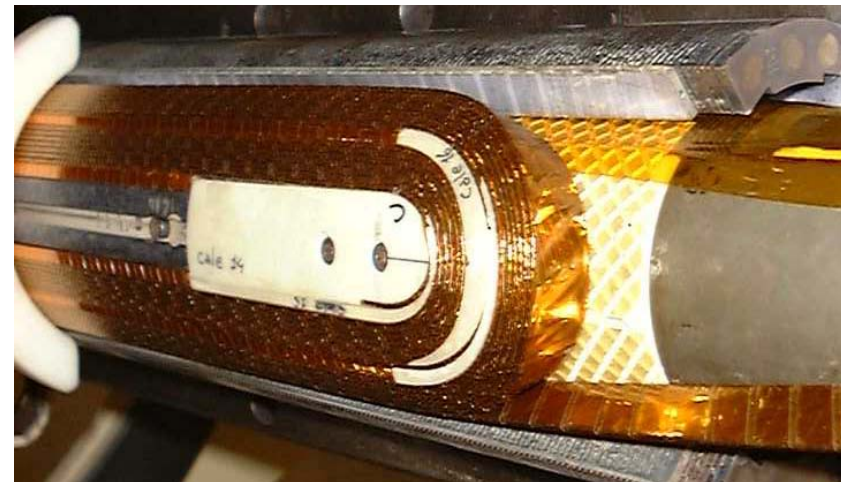

# Critical line and magnet load lines

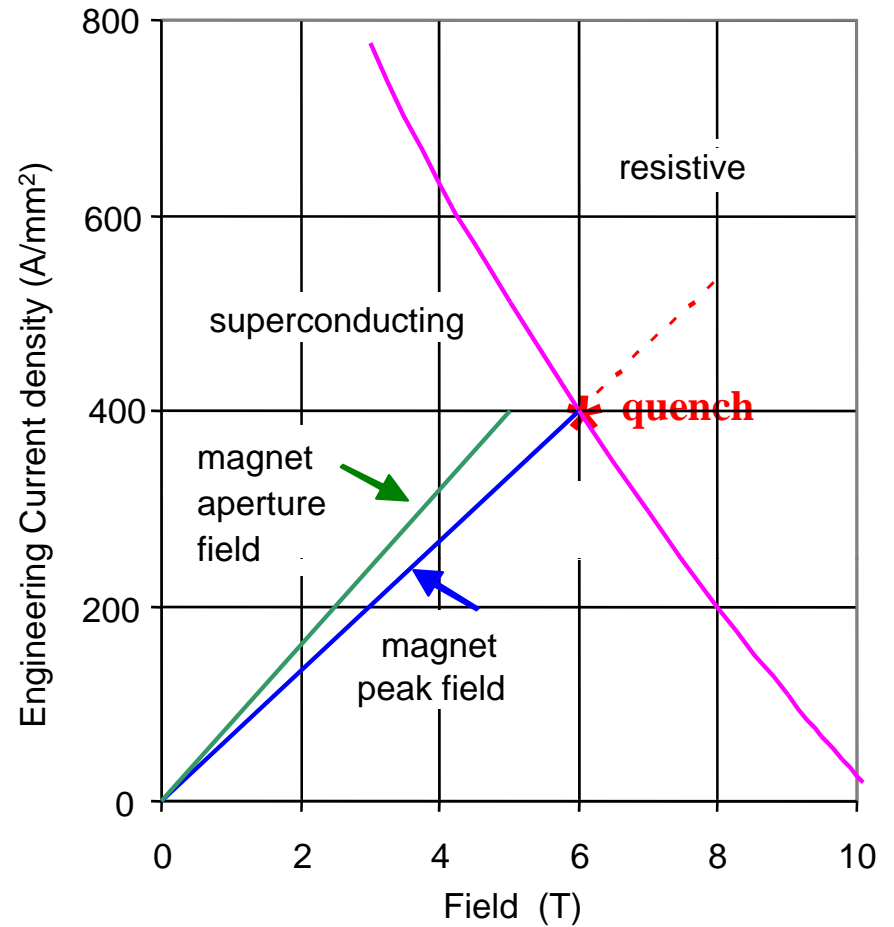
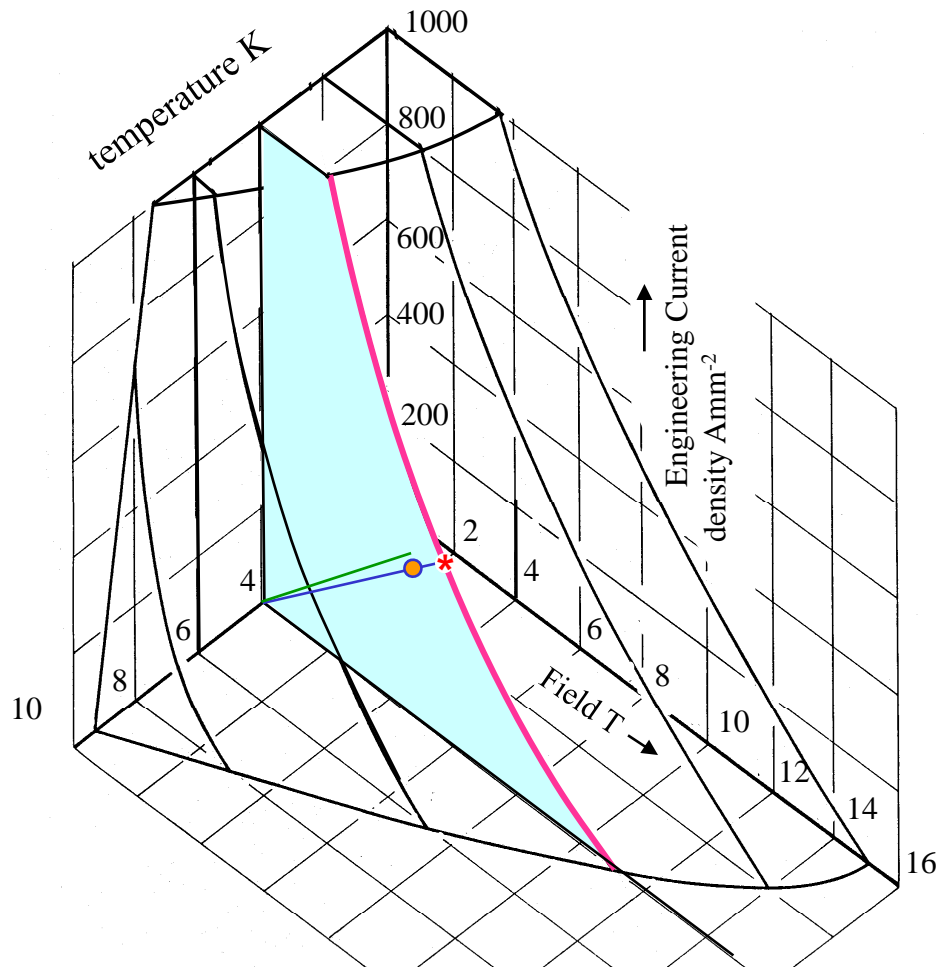

we expect the magnet to go resistive '*quench*' where the peak field load line crosses the critical current line \*

# 'Training' of magnets

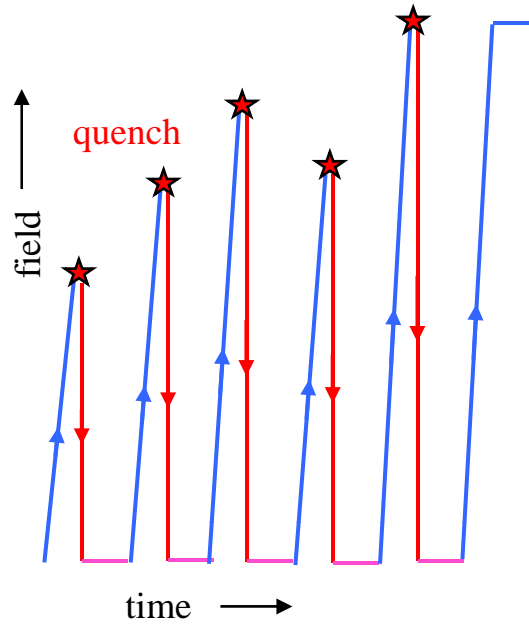

- when the current (and field) of a magnet is ramped up for the first time, it usually 'quenches' (goes resistive) at less than the expected current
- at the next try it does better
- known as **training**

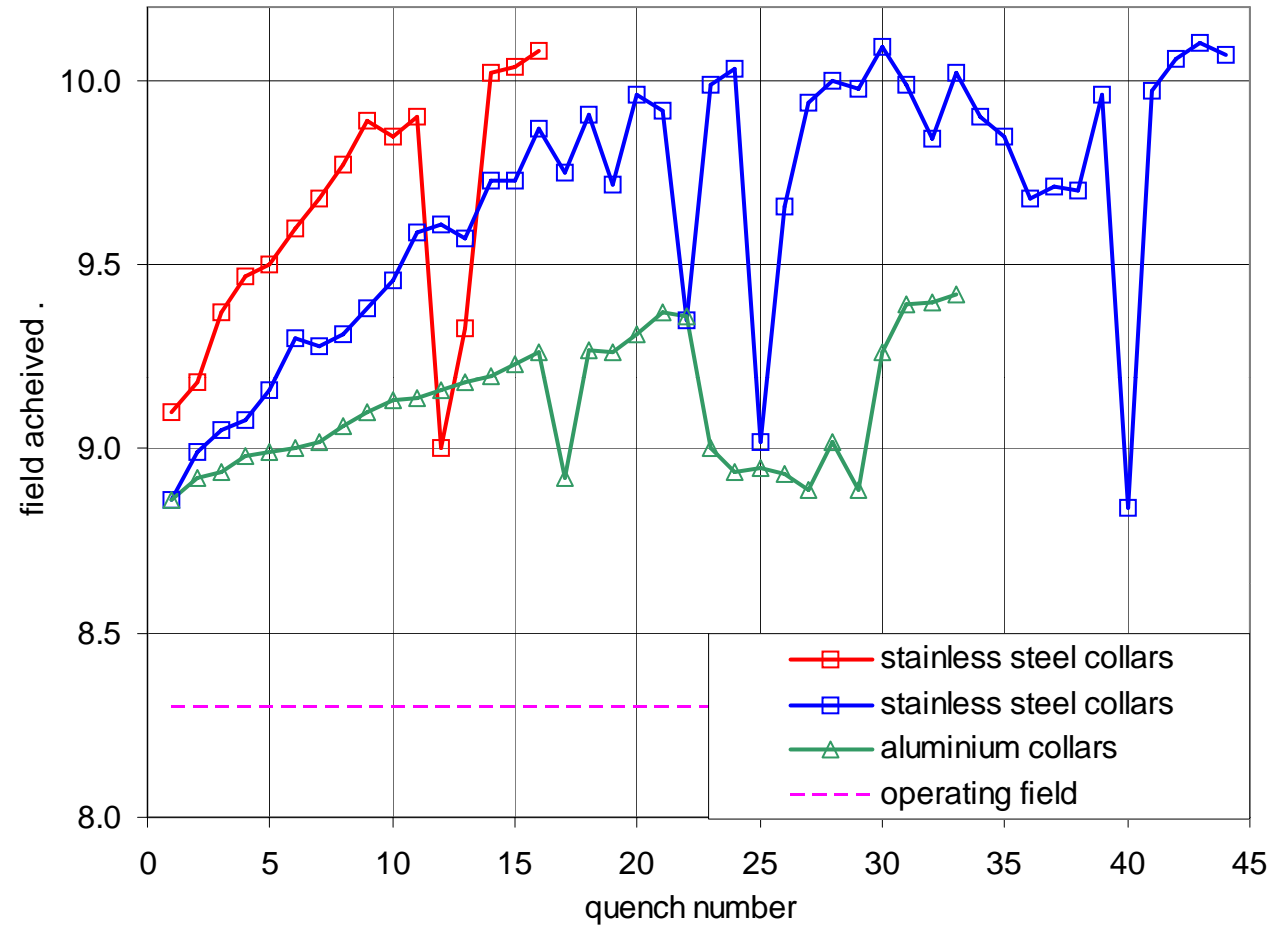

Training of LHC short prototype dipoles (from A. Siemko)

## Causes of training: (1) low specific heat

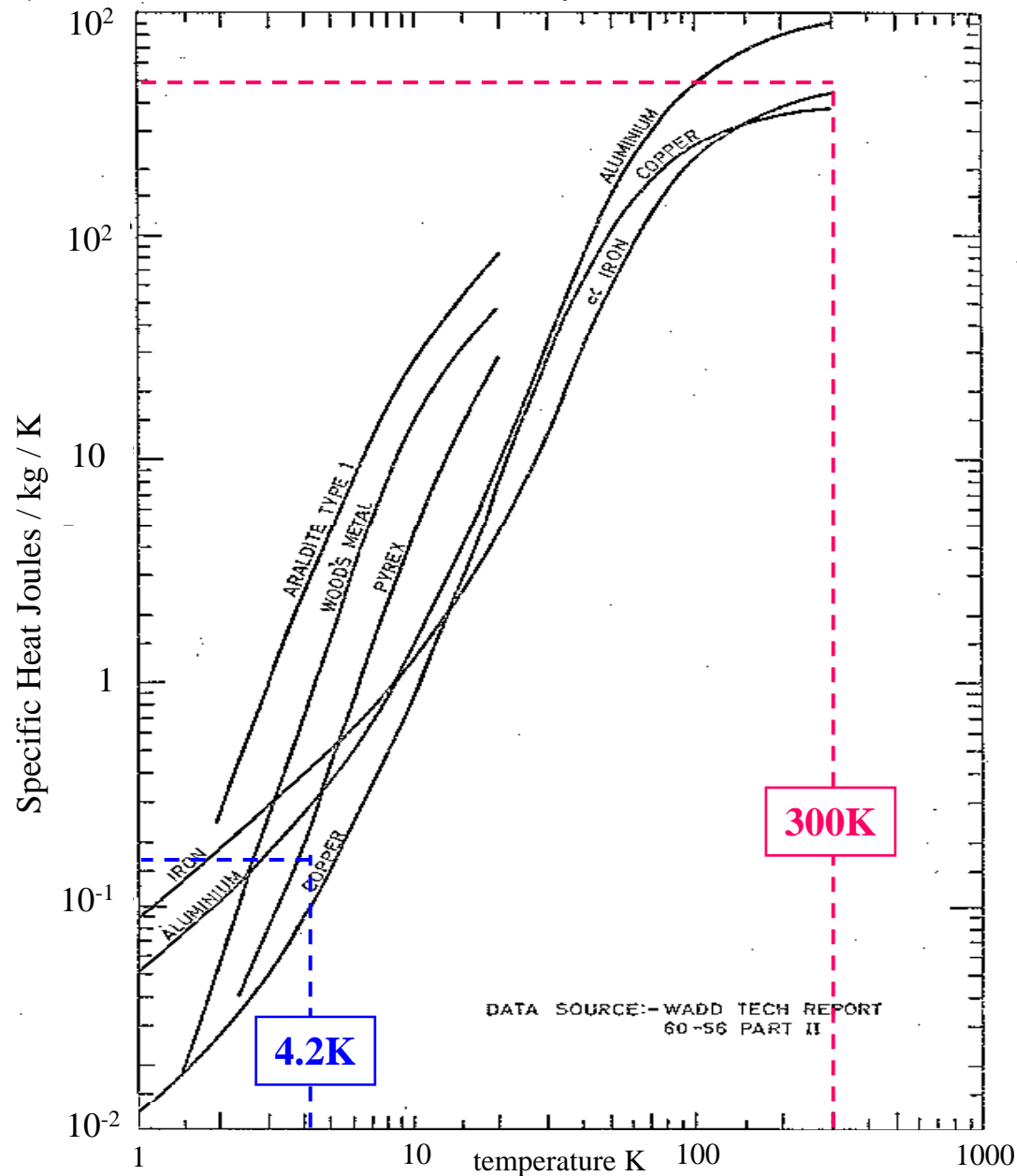

- the specific heat of all substances falls with temperature
- at 4.2K, it is **~2,000 times** less than at room temperature
- a given release of energy within the winding thus produce a temperature rise 2,000 times greater than at room temperature
- the smallest energy release can therefore produce catastrophic effects

## Causes of training: (2) conductor motion

- Big electromagnetic forces in magnets
- Bursting force in LHC dipoles = 320 tonne/m
- Conductors are pushed by the electromagnetic forces.
- Frictional heating if they move

work done per unit length of conductor if it is pushed a distance  $\delta z$

$$W = F. \delta z = B.I. \delta z$$

frictional heating per unit volume

$$Q = B.J. \delta z$$

typical numbers for NbTi:

$$B = 5\text{T} \quad J_{\text{eng}} = 5 \times 10^8 \text{ A.m}^{-2}$$

$$\text{so if } \delta = 10 \mu\text{m}$$

$$\text{then } Q = 2.5 \times 10^4 \text{ J.m}^{-3}$$

Starting from 4.2K  $\theta_{\text{final}} = 7.5\text{K}$

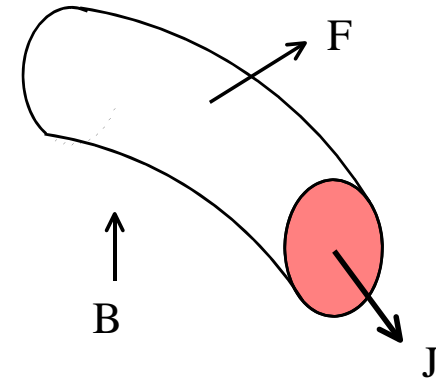

can you  
engineer a  
winding to  
better than  
**10  $\mu\text{m}$ ?**





# Causes of training: (3) resin cracking

- try to stop wire movement by impregnating the winding with epoxy resin
- the resin contracts much more than the metal - so it goes into tension
- it also become brittle at low temperature.

*brittleness + tension  $\Rightarrow$  cracking  $\Rightarrow$  energy release*

## Calculate the stain energy induced in resin by differential thermal contraction

let:  $\sigma$  = tensile stress       $Y$  = Young's modulus  
 $\epsilon$  = differential strain       $\nu$  = Poisson's ratio

thermal contraction of Cu  $\sim 3 \times 10^{-3}$  (room to 4K)

thermal contraction of resin  $\sim 11 \times 10^{-3}$

so  $\epsilon = (11 - 3) \times 10^{-3}$

typically  $Y = 7 \times 10^9$  Pa       $\nu = 1/3$

strain energy       $Q_1 = \frac{\sigma^2}{2Y} = \frac{Y\epsilon^2}{2}$        $Q_1 = 2.5 \times 10^5$  J.m<sup>-3</sup>      (*uniaxial strain*)

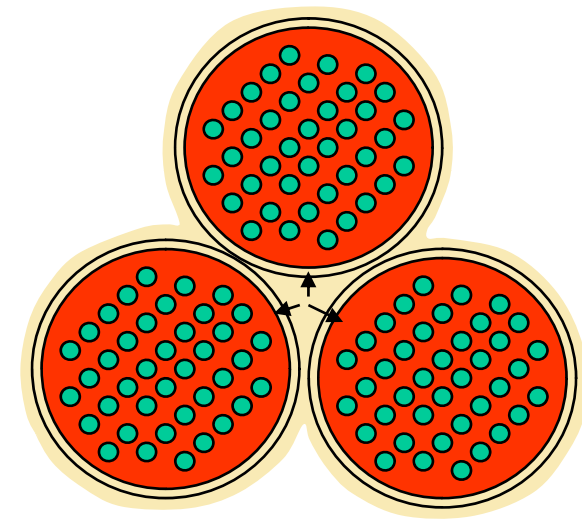

if released adiabatically, raises temperature to       $\theta_{final} = 16K$

# How to reduce training?

## 1) Reduce the disturbances occurring in the magnet winding

- make the winding fit together exactly to reduce movement of conductors under field forces
- pre-compress the winding to reduce movement under field forces
- if using resin, minimize the volume and choose a crack resistant type
- match thermal contractions, eg fill epoxy with mineral or glass fibre

**most accelerator magnets are insulated using a Kapton film with a thin adhesive coating**

## 2) Make the conductor able to withstand disturbances without quenching

- increase the **temperature margin**
- increase the **minimum quench energy**

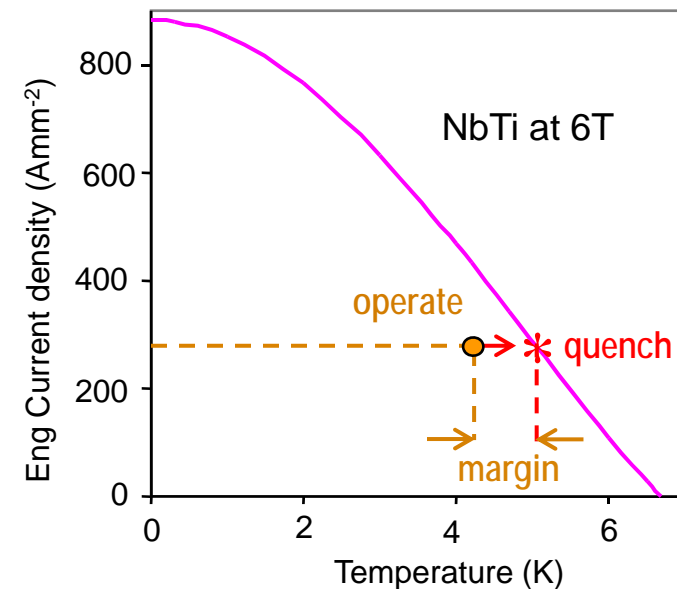
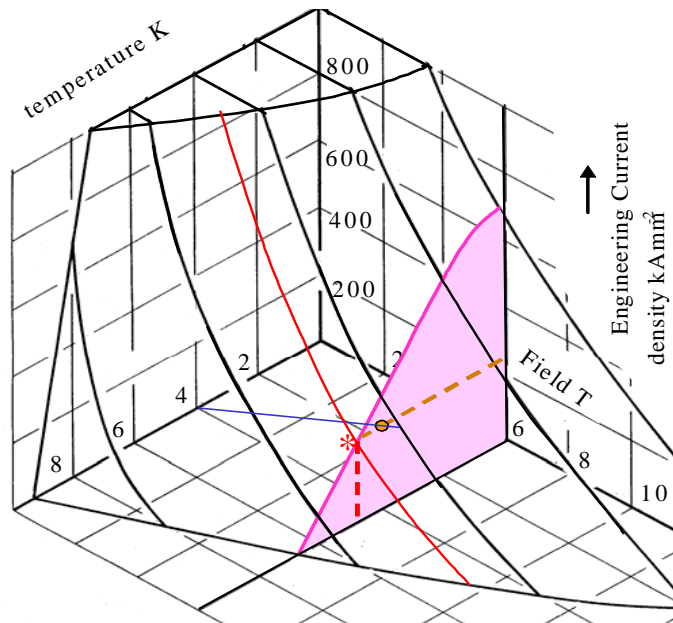

# Minimum quench energy MQE

- MQE is the smallest energy input which quenches the conductor.
- measure it by injecting short (100 $\mu$ s) heat pulses at a point on the conductor.

**large MQE**

$\Rightarrow$  **more stable conductor**  
 $\Rightarrow$  **less training**

**for a large MQE we need:**

- large temperature margin
- large thermal conductivity – need copper
- small resistivity – need copper
- large specific heat – difficult
- good cooling – winding porous to liquid helium coolant

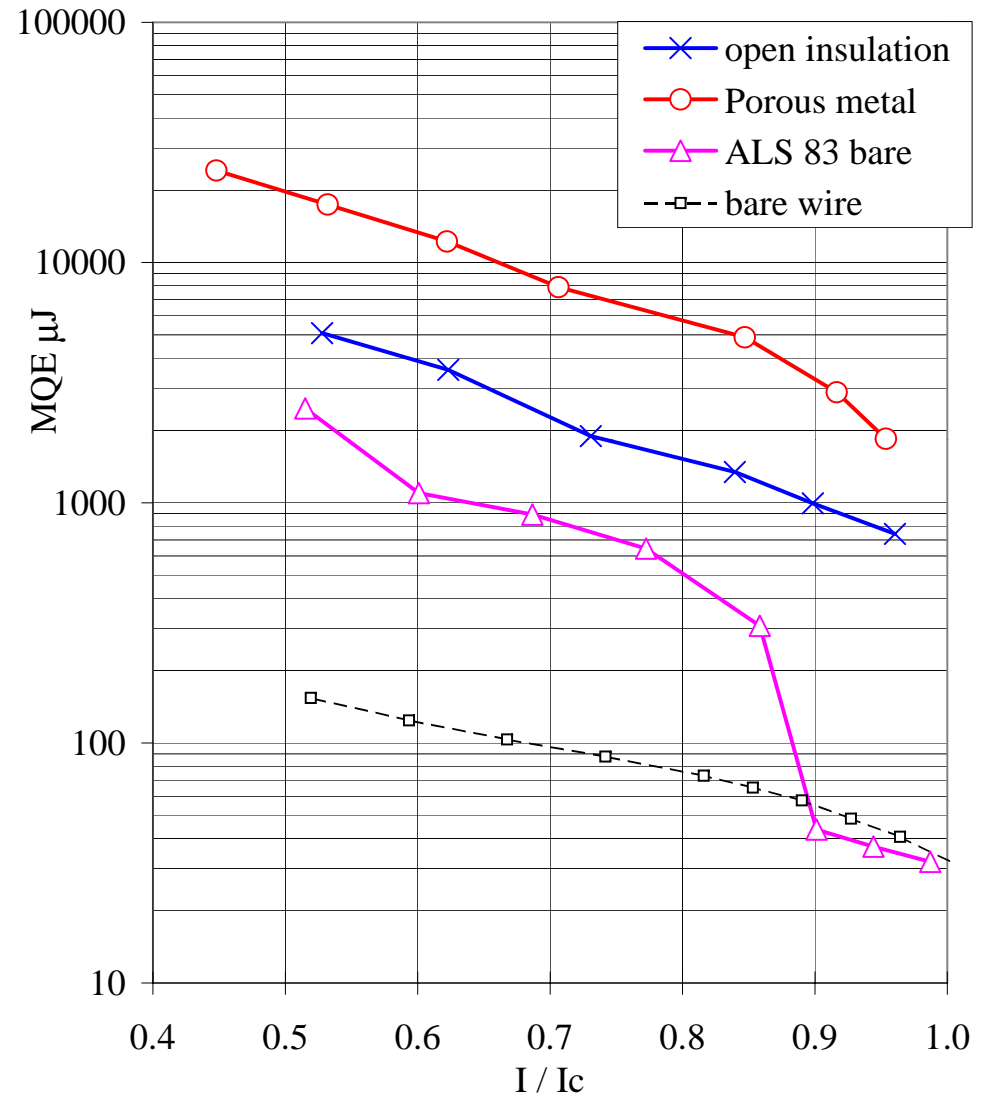

# Persistent screening currents

- when a superconductor is subjected to a changing magnetic field, screening currents are induced to flow
- **screening currents** are in addition to the **transport current**, which comes from the power supply
- they are like eddy currents but, because there is no resistance, they don't decay

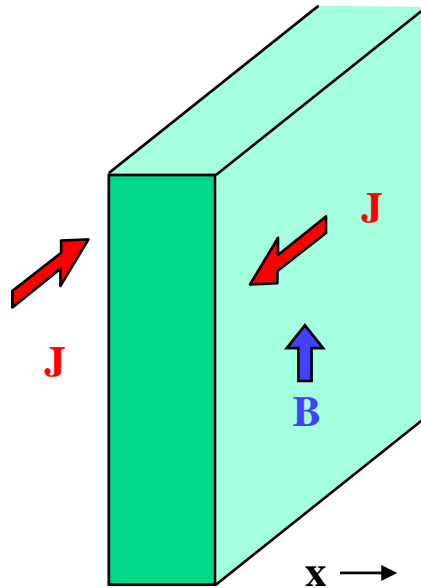

- usual model is a superconducting slab in a changing magnetic field  $B_y$
- assume it's infinitely long in the  $z$  and  $y$  directions - simplifies to a 1 dim problem
- $dB/dt$  induces an electric field  $E$  which causes screening currents to flow at critical current density  $J_c$
- known as the **critical state model** or **Bean model**
- in the 1 dim infinite slab geometry, Maxwell's equation says

$$\frac{\partial B_y}{\partial x} = -\mu_0 J_z = \mu_0 J_c$$

- so uniform  $J_c$  means a constant field gradient inside the superconductor

# The flux penetration process

plot field profile across the slab

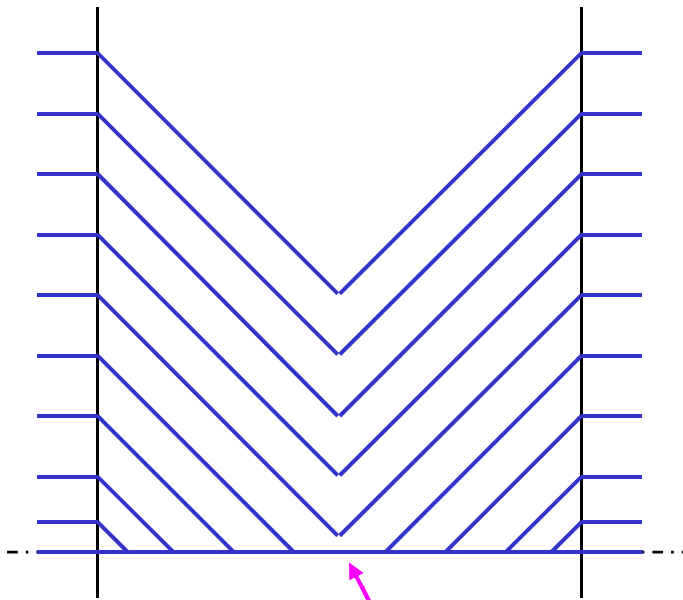

fully penetrated

field increasing from zero

*everywhere current density is  $\pm J_c$  or zero*  
(Critical State or Bean model)

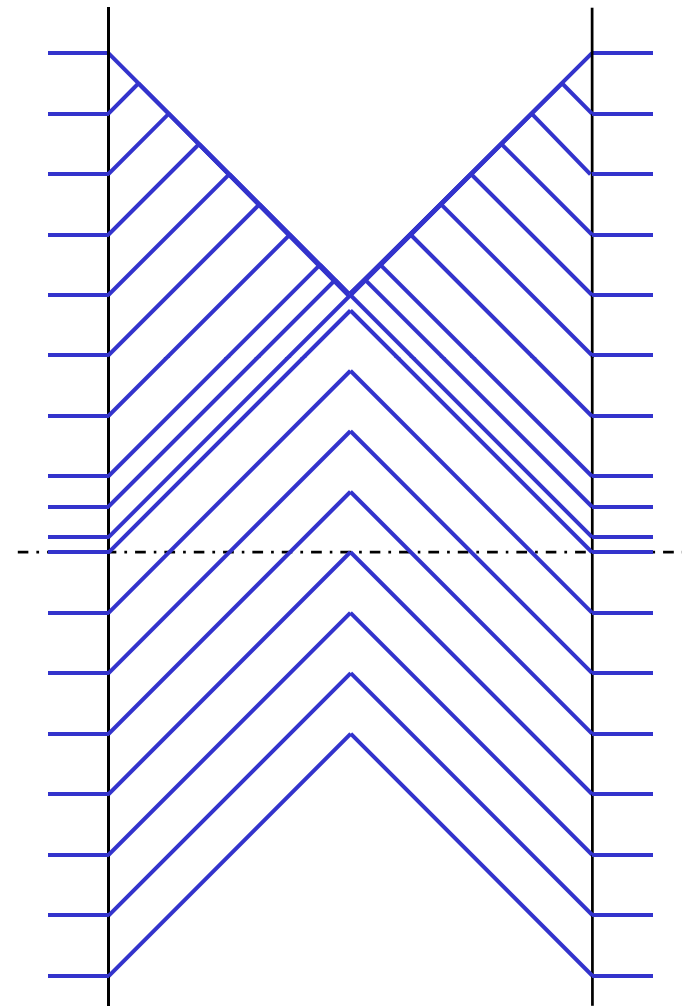

field decreasing through zero

# Magnetization of the Superconductor

When viewed from outside the sample, the persistent currents produce a magnetic moment.

define a magnetization (magnetic moment per unit volume)

$$M = \sum_V \frac{I \cdot A}{V} \quad \text{NB units of } H$$

for a fully penetrated slab

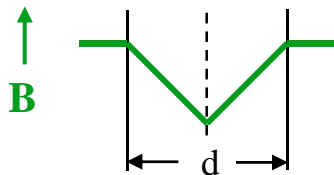

$$M = \frac{1}{a} \int_0^a J_c x dx = \frac{J_c a}{4}$$

for **cylindrical** filaments the inner current boundary is roughly elliptical (controversial)

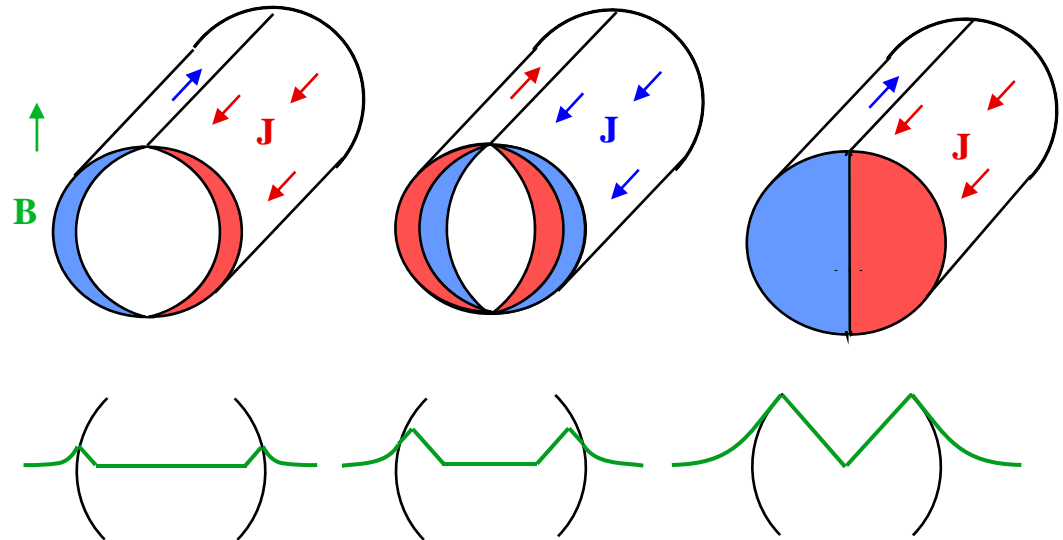

when fully penetrated, the magnetization is

$$M = \frac{2}{3\pi} J_c d_f$$

where  $d_f$  = filament diameter

Note:  $M$  is here defined per unit volume of NbTi filament

# Magnetization of NbTi

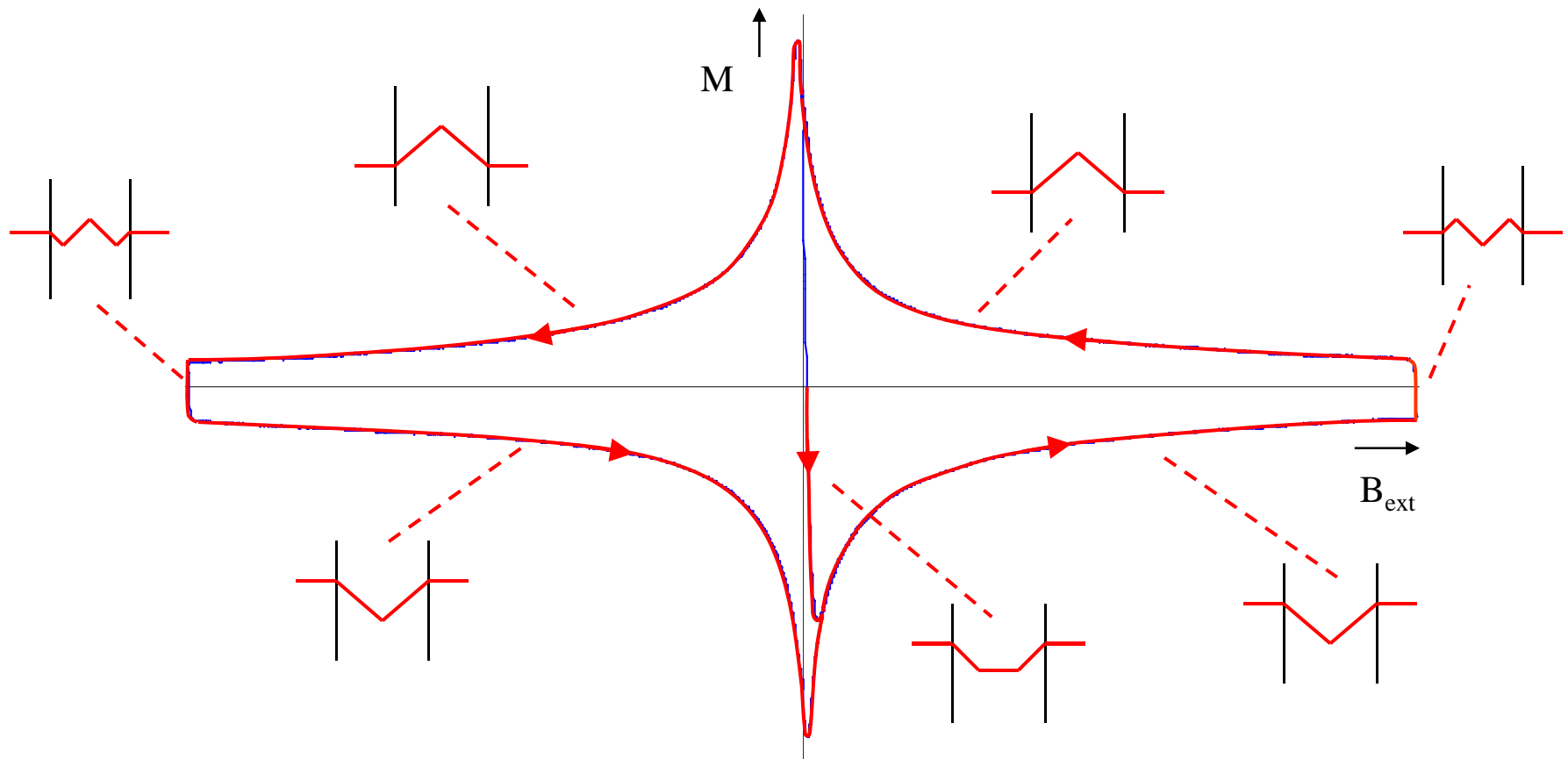



# Coupling between filaments

recap  $M = \frac{2}{3\pi} J_c d_f$

- reduce M by making fine filaments
- for ease of handling, filaments are embedded in a copper matrix

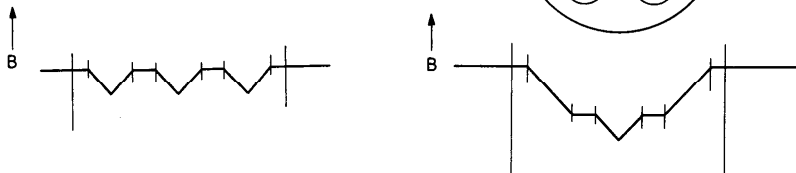
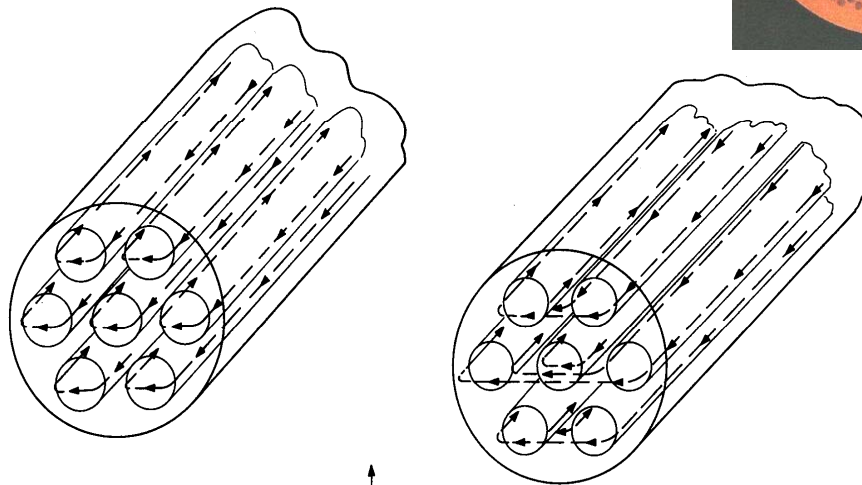
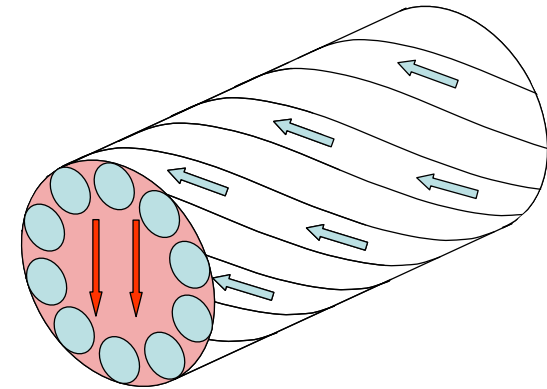
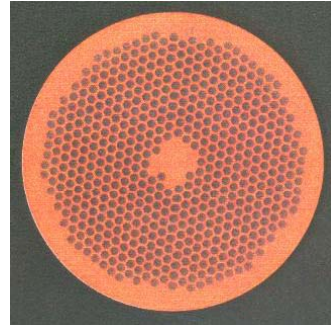

- but in changing fields, the filaments are magnetically coupled
- screening currents go up the left filaments and return down the right

- fortunately the coupling currents may be reduced by twisting the wire
- coupling currents behave like eddy currents and produce an additional magnetization

$$M_e = \frac{dB}{dt} \frac{1}{\rho_t} \left[ \frac{p_w}{2\pi} \right]^2$$

where  $\rho_t$  = resistivity across the copper  
and  $p_w$  = wire twist pitch

# Coupling $\Rightarrow$ rate dependent magnetization

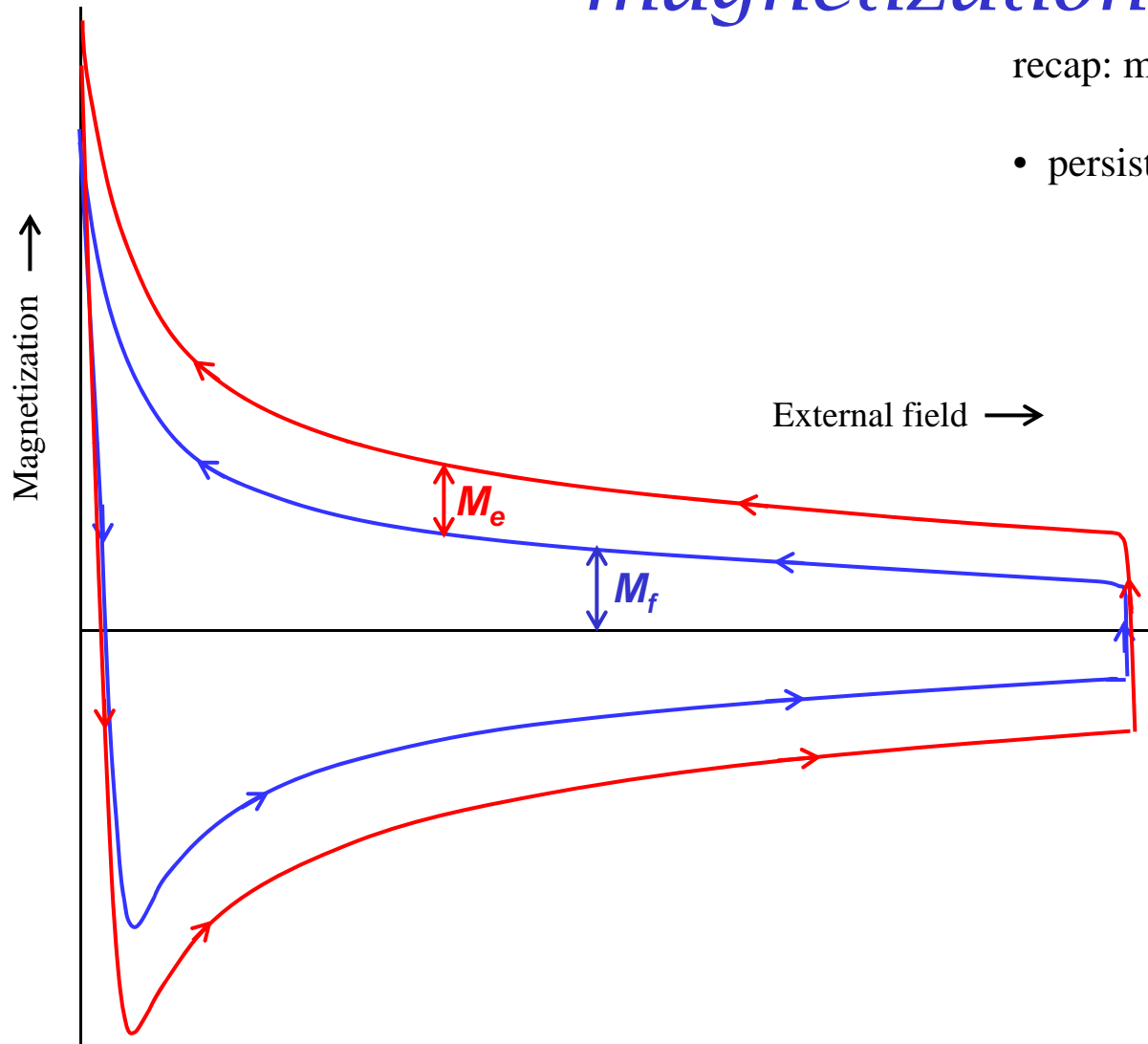

recap: magnetization has two components:

- persistent current in the filaments

$$M_f = \frac{2}{3\pi} J_c(B) d_f$$

**$M_f$  depends on  $B$**

- and eddy current coupling between the filaments

$$M_e = \frac{dB}{dt} \frac{l}{\rho_t} \left[ \frac{p_w}{2\pi} \right]^2$$

**$M_e$  depends on  $dB/dt$**

*Note  $M_f$  defined per unit volume of NbTi filament  
and  $M_e$  per unit volume of wire*

# Magnetization and field errors

Magnetization is important in accelerators because it produces field error. The effect is worst at injection because

- $\Delta B/B$  is greatest
- magnetization, ie  $\Delta B$  is greatest at low field

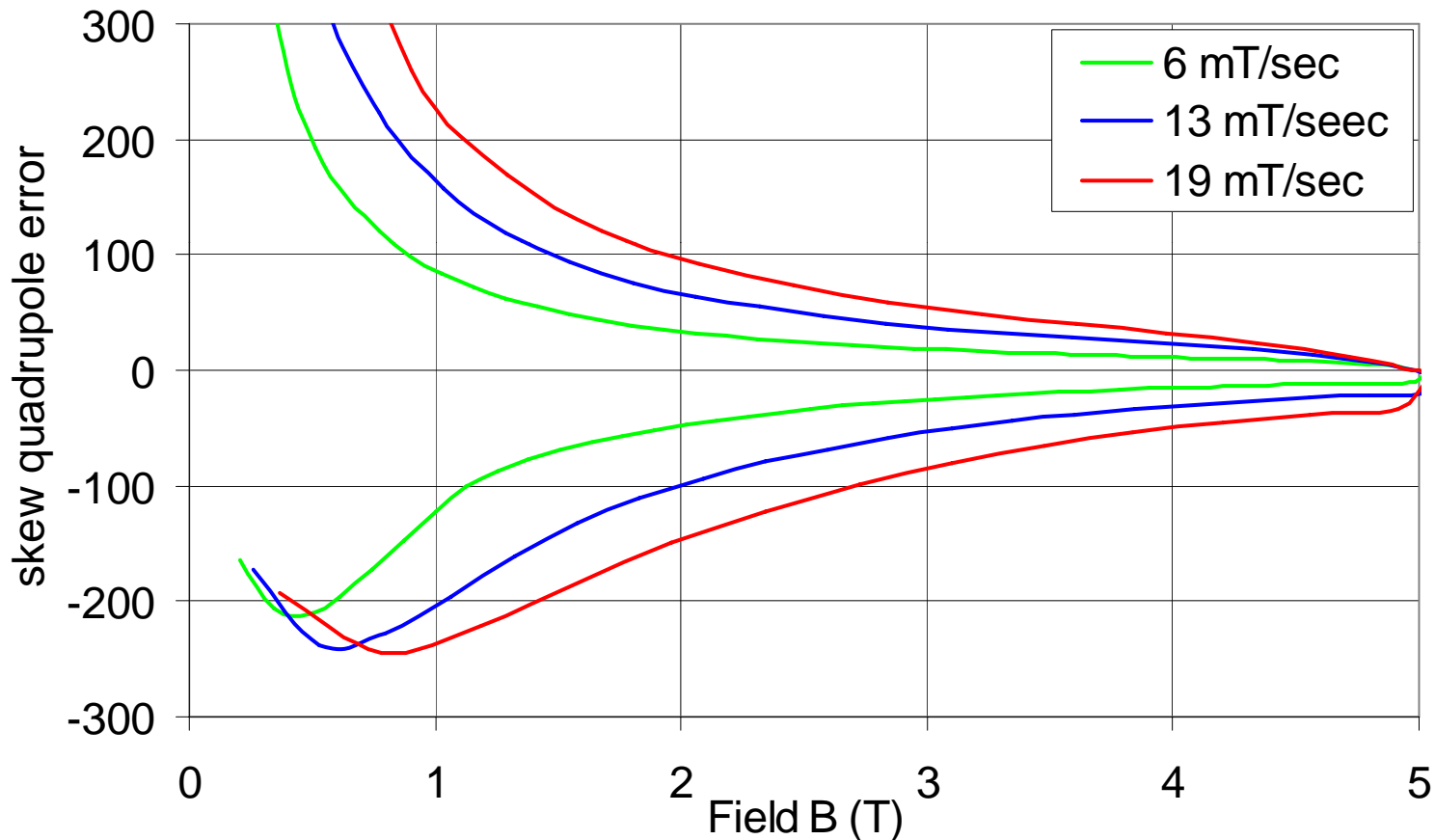

*skew  
quadrupole  
error in  
Nb<sub>3</sub>Sn dipole  
which has  
exceptionally  
large  
coupling  
magnetization  
(University of  
Twente)*

# Synchrotron injection

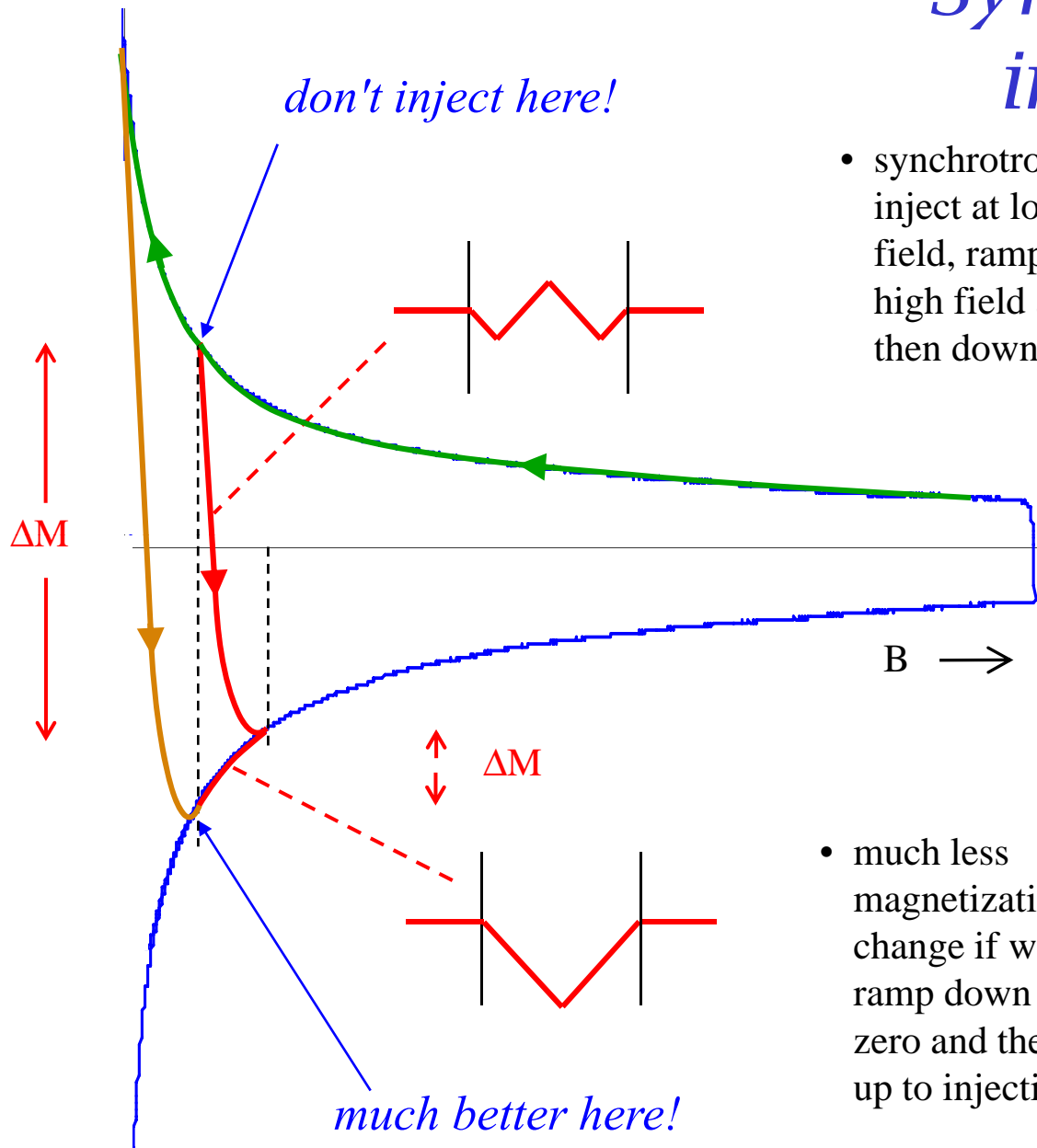

- synchrotrons inject at low field, ramp to high field and then down again

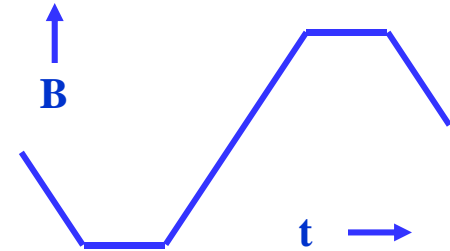

- note how quickly the magnetization changes when we start the ramp up

- much less magnetization change if we ramp down to zero and then up to injection

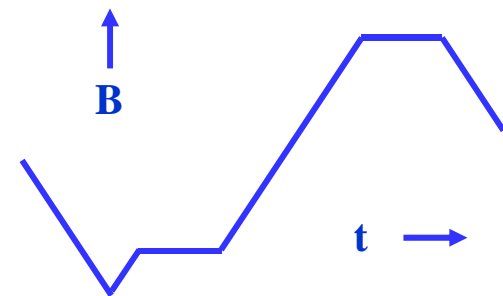

# Why cables?

- for good tracking we connect synchrotron magnets in series
- if stored energy is  $E$ , rise time  $t$  and operating current  $I$ , the charging voltage is

$$E = \frac{1}{2} LI^2 \qquad V = \frac{LI}{t} = \frac{2E}{It}$$

- for a given magnet size and field the stored energy  $E$  is fixed
- so to keep a reasonable voltage  $V$  we need high current
- a composite wire of fine filaments typically has 5,000 to 10,000 filaments, so it carries 250A to 500A
- for 5 to 10kA, we need 20 to 40 wires in parallel - **a cable**



*the RHIC tunnel*



# Rutherford cable

- fully transposed - every strand changes places with every other
- cable insulated by wrapping 2 or 3 layers of Kapton
- gaps may be left to allow penetration of liquid helium
- outer layer is treated with an adhesive layer for bonding to adjacent turns.

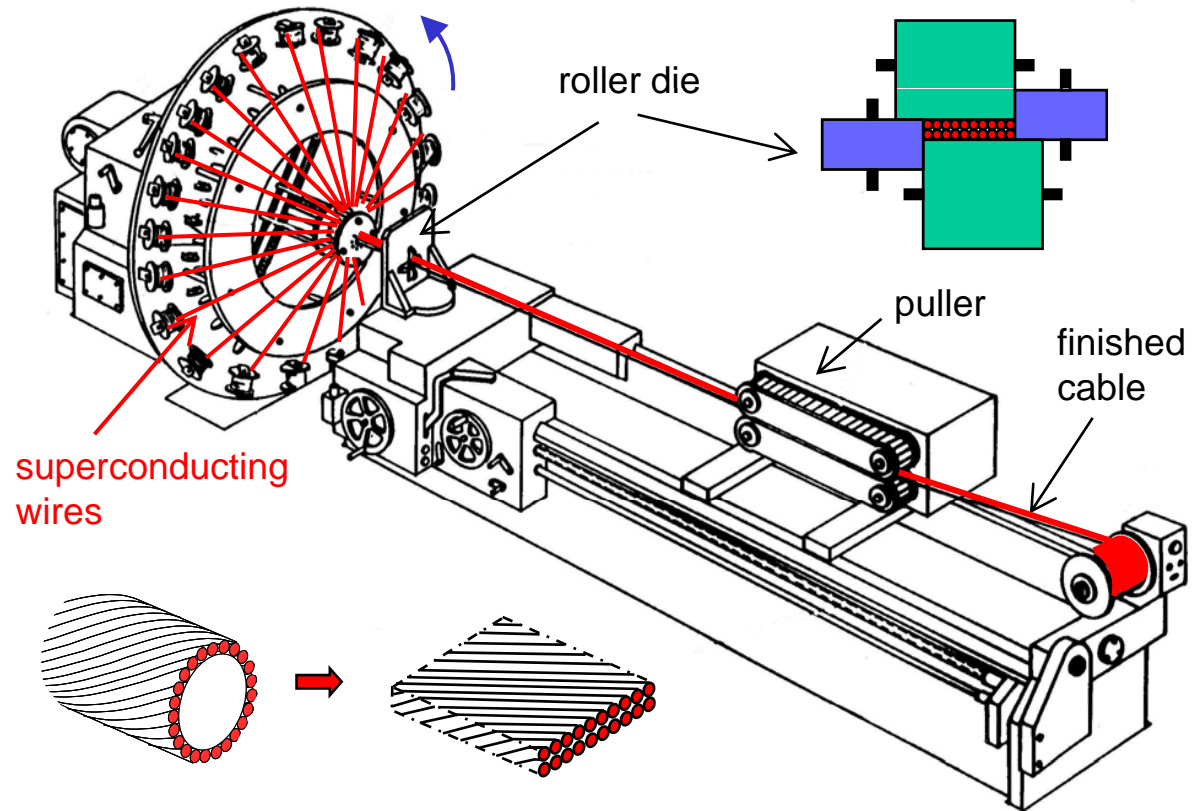
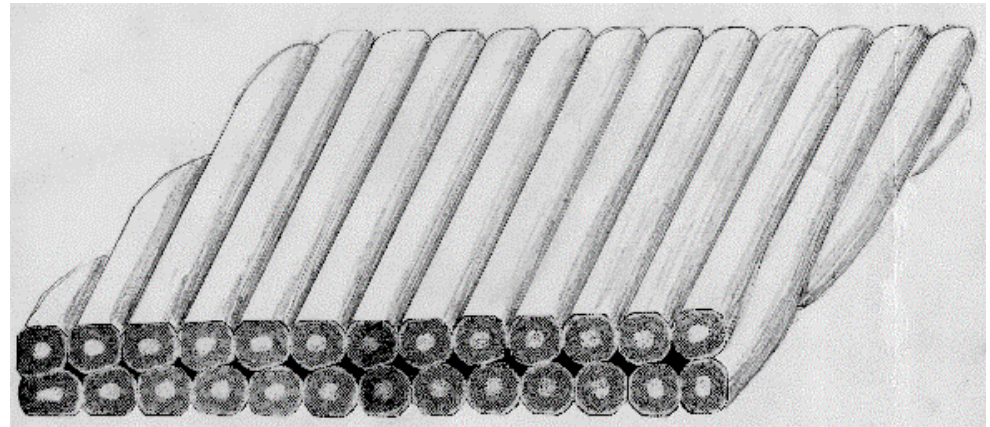
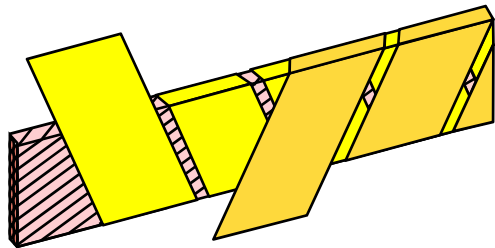

# Coupling in Rutherford cables

- To enable current sharing, we keep some electrical contact between strands of the cable

crossover resistance  $R_c$

adjacent resistance  $R_a$

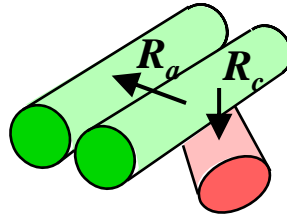

- Changing transverse fields induce coupling currents via the crossover resistance  $R_c$

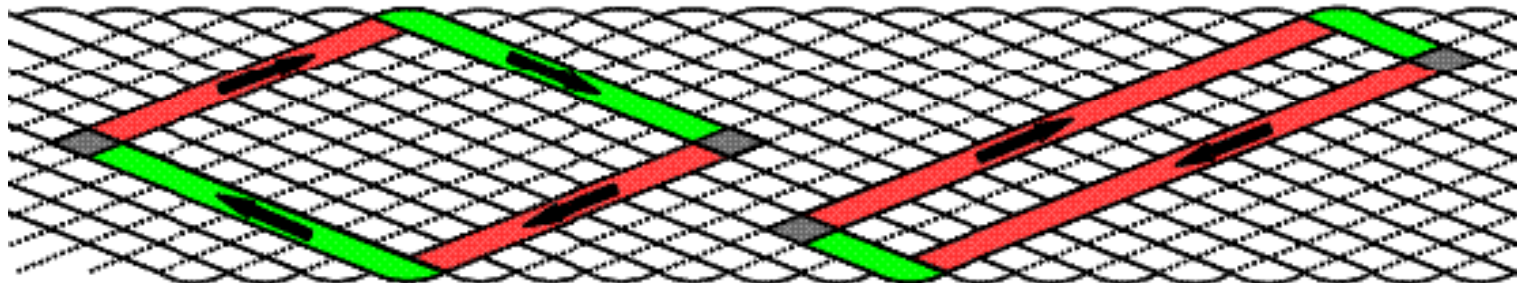
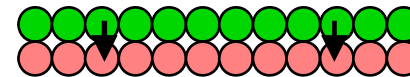

# Cable coupling adds more magnetization

filament magnetization  $M_f$  depends on  $B$

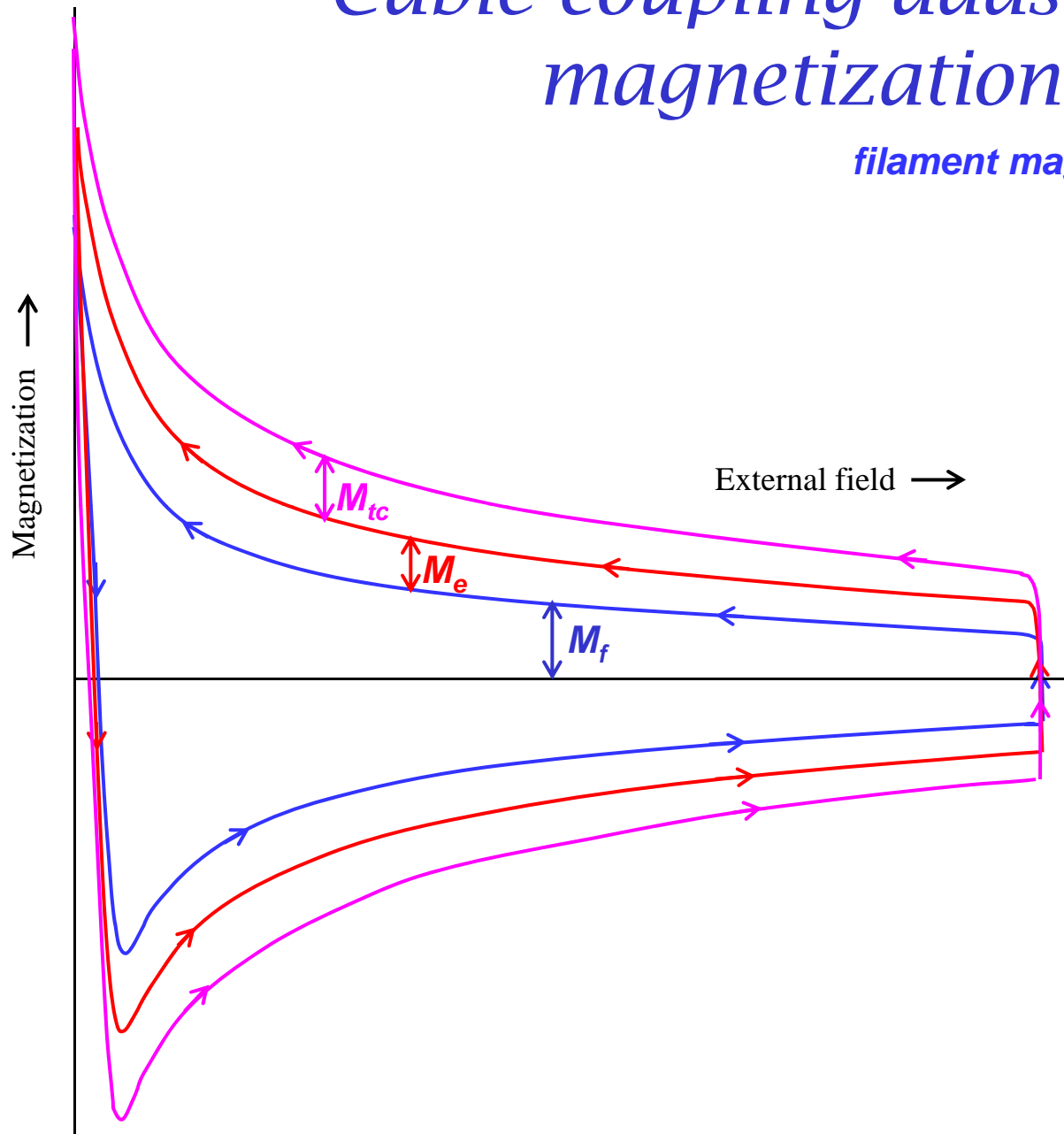

coupling between filaments  $M_e$  depends on  $dB/dt$

coupling between wires in cable depends on  $dB/dt$



# AC losses

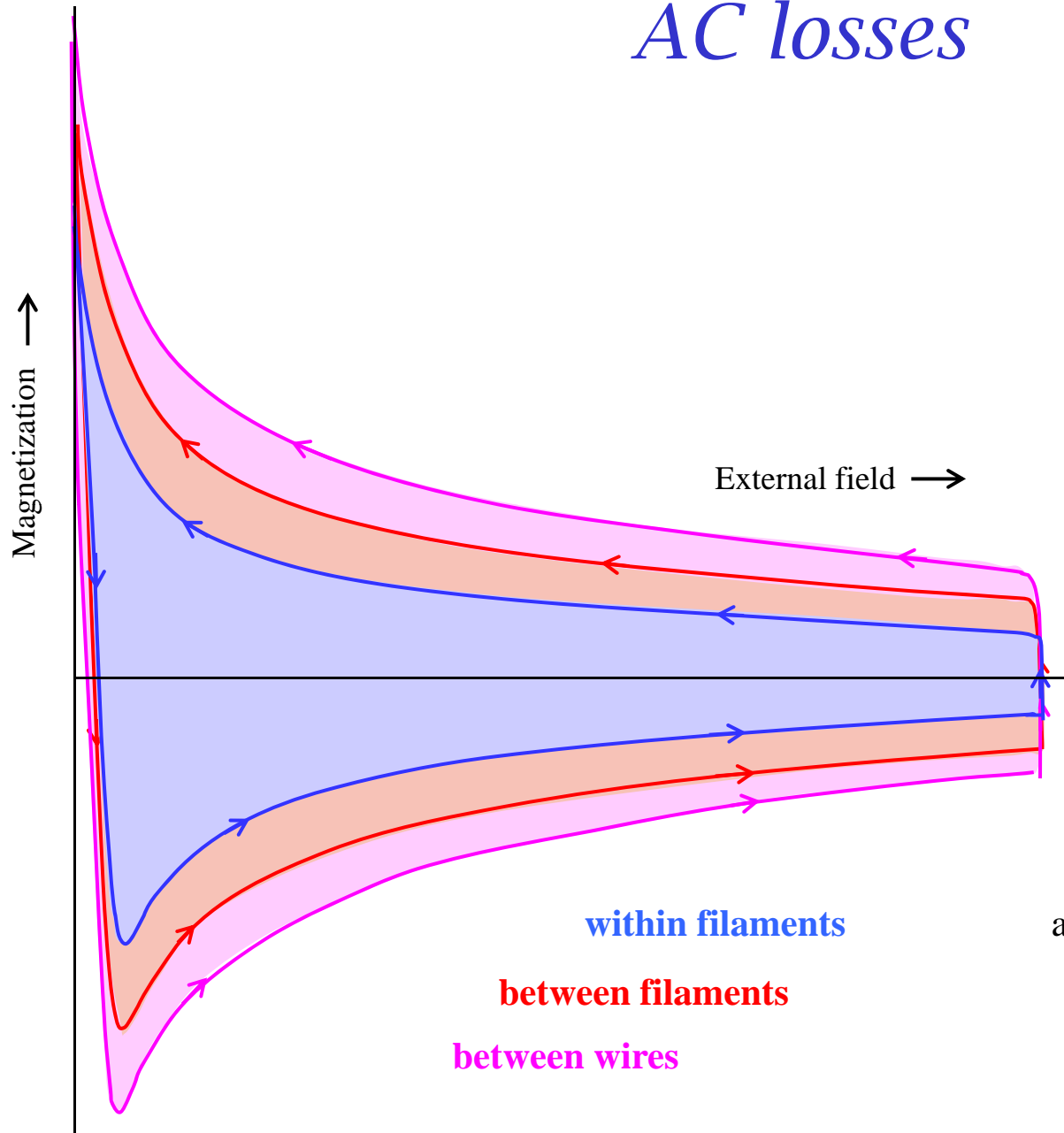

For a magnet material, work done by magnetic field

$$dW = \mu_o HdM$$

around a closed loop

$$W = \int \mu_o HdM$$

- loop comes back to same place
- field energy is same
- so work done is ac loss in material

ac loss is area of hysteresis loop

$$W = \int \mu_o HdM = \int \mu_o MdH$$

# Quenching: magnetic stored energy

**Magnetic energy density**  $E = \frac{B^2}{2\mu_0}$  at 5T  $E = 10^7$  Joule.m<sup>-3</sup> at 10T  $E = 4 \times 10^7$  Joule.m<sup>-3</sup>

**LHC dipole magnet (twin apertures)**  $E = \frac{1}{2}LI^2$   $L = 0.12$ H  $I = 11.5$ kA  $E = 7.8 \times 10^6$  Joules

the magnet weighs 26 tonnes

so the magnetic stored energy is equivalent to the kinetic energy of:-

**26 tonnes travelling at 88km/hr**



coils weigh 830 kg

equivalent to the kinetic energy of:-

**830kg travelling at 495km/hr**

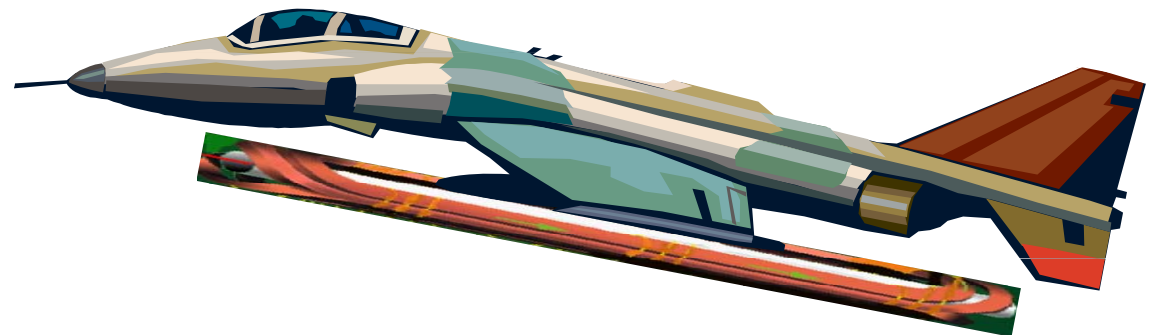

# The quench process

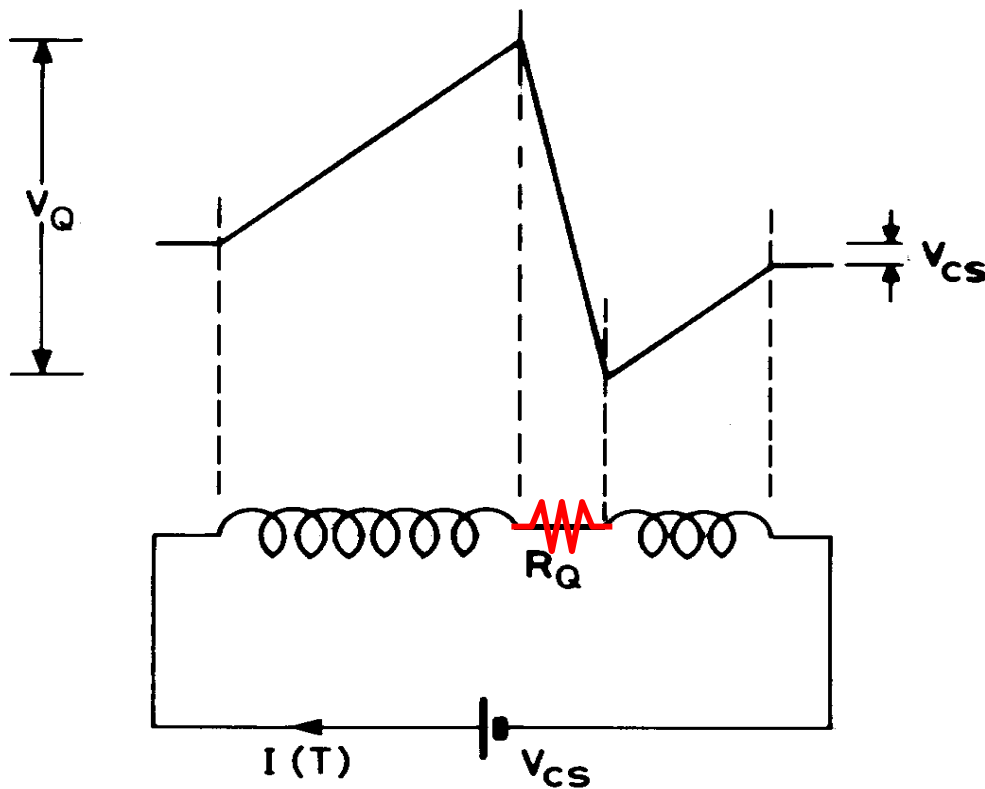

- resistive region starts somewhere in the winding at a **point**  
- **this is the problem!**
- it grows by thermal conduction
- stored energy  $\frac{1}{2}LI^2$  of the magnet is dissipated as heat
- greatest integrated heat dissipation is at point where the quench starts
- internal voltages much greater than terminal voltage ( $= V_{cs}$  current supply)
- maximum temperature may be calculated from the current decay time via the  $U(\theta)$  function (adiabatic approximation)

# The temperature rise function $U(\theta)$

or the 'fuse blowing' calculation  
(adiabatic approximation)

$$J^2(T)\rho(\theta)dT = \gamma C(\theta)d\theta$$

$J(T)$  = overall current density,  
 $T$  = time,  
 $\rho(\theta)$  = overall resistivity,  
 $\gamma$  = density,  $\theta$  = temperature,  
 $C(\theta)$  = specific heat,  
 $T_Q$  = quench decay time.

$$\int_0^\infty J^2(T)dT = \int_{\theta_0}^{\theta_m} \frac{\gamma C(\theta)}{\rho(\theta)} d\theta$$

$$= U(\theta_m)$$

$$J_o^2 T_Q = U(\theta_m)$$

- GSI 001 dipole winding is  
 50% copper, 22% NbTi,  
 16% Kapton and 3% stainless steel

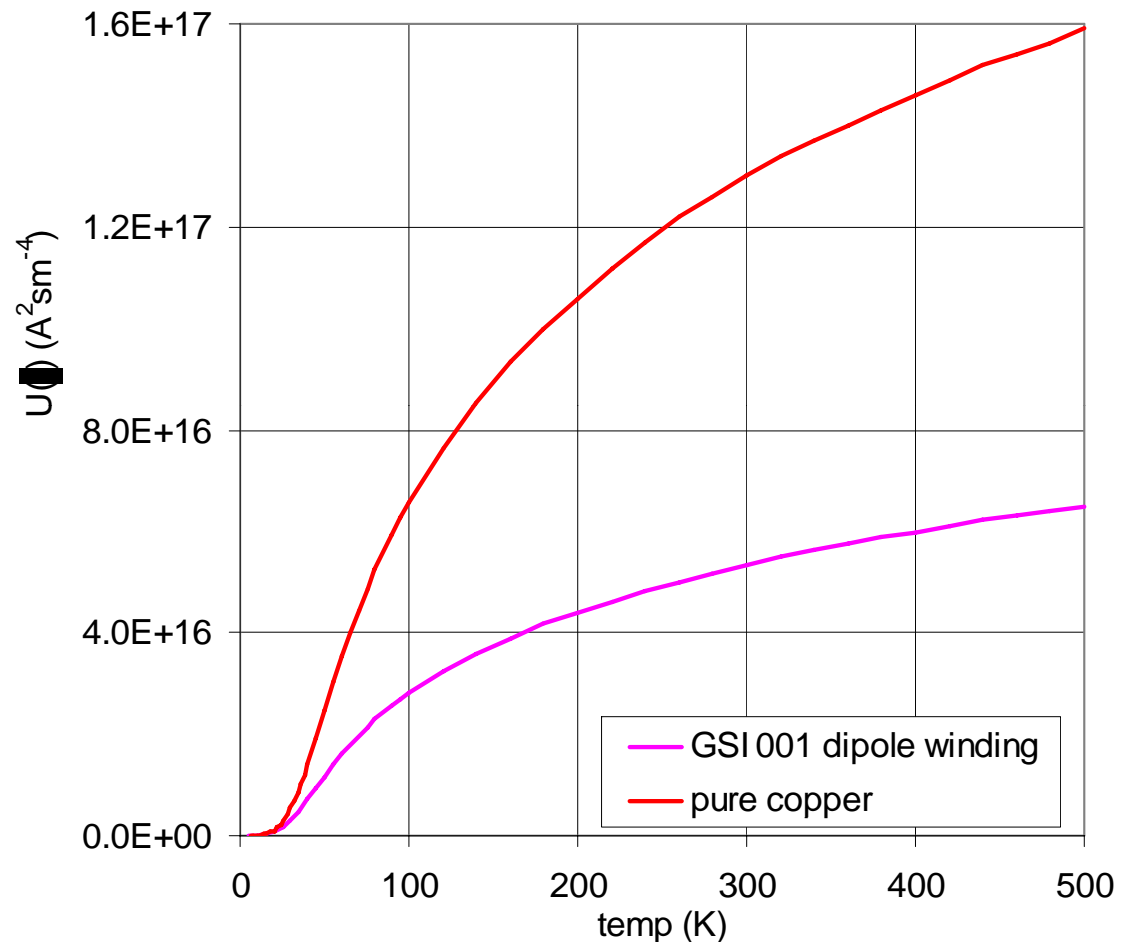

- NB always use **overall** current density

# Measured current decay after a quench

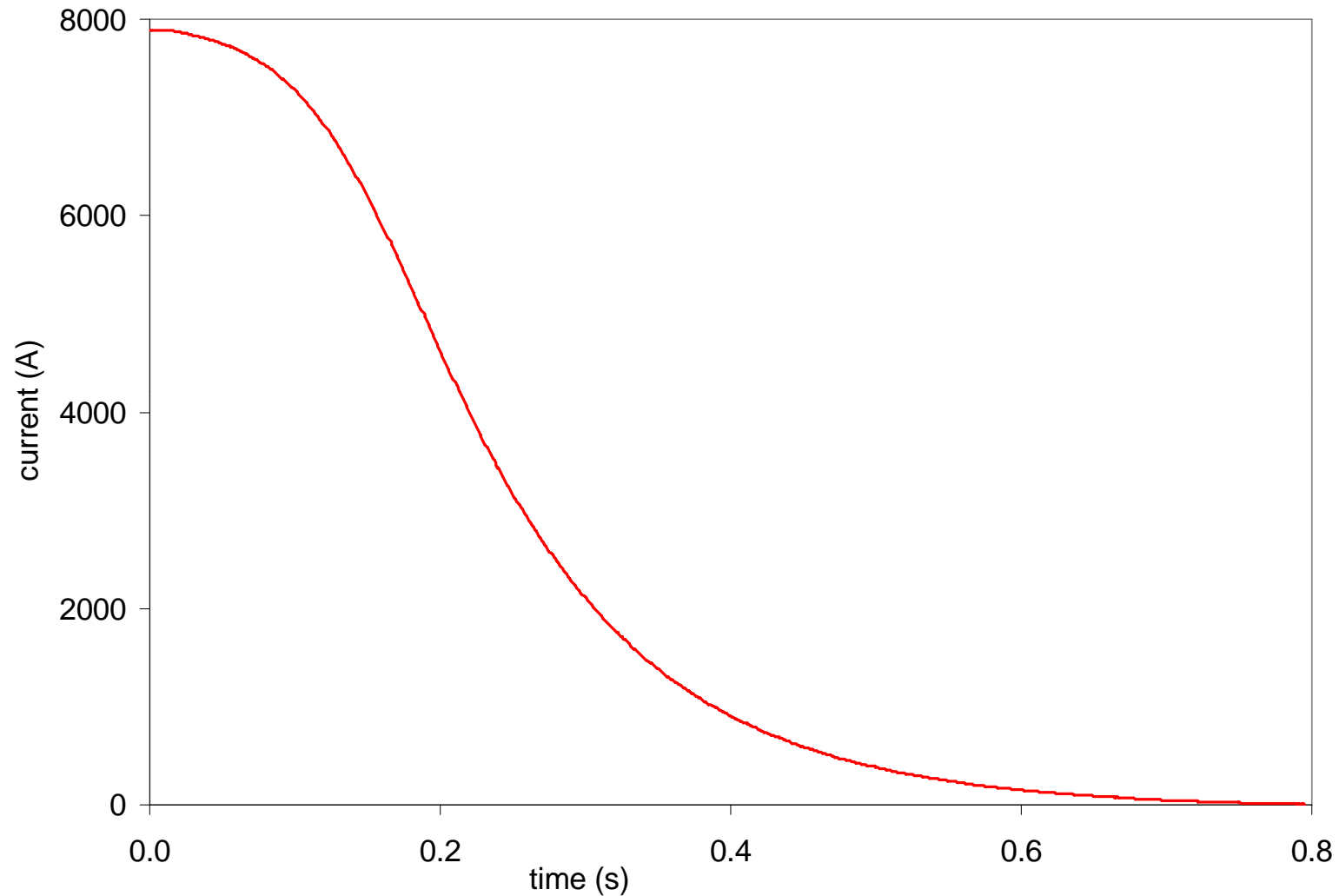

*Dipole GSI001 measured at Brookhaven National Laboratory*

# Calculating the temperature rise from the current decay curve

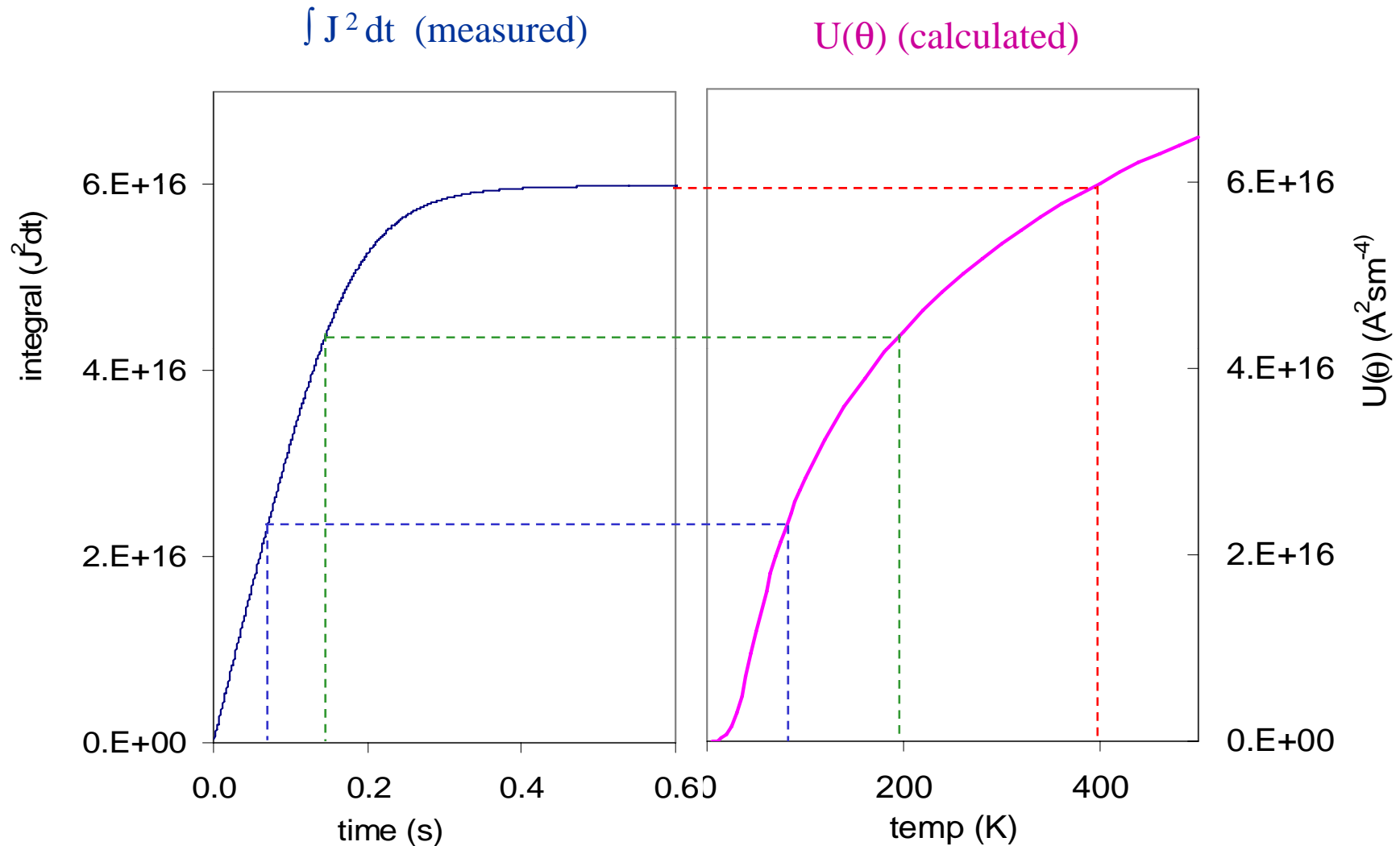

# *Growth of the resistive zone*

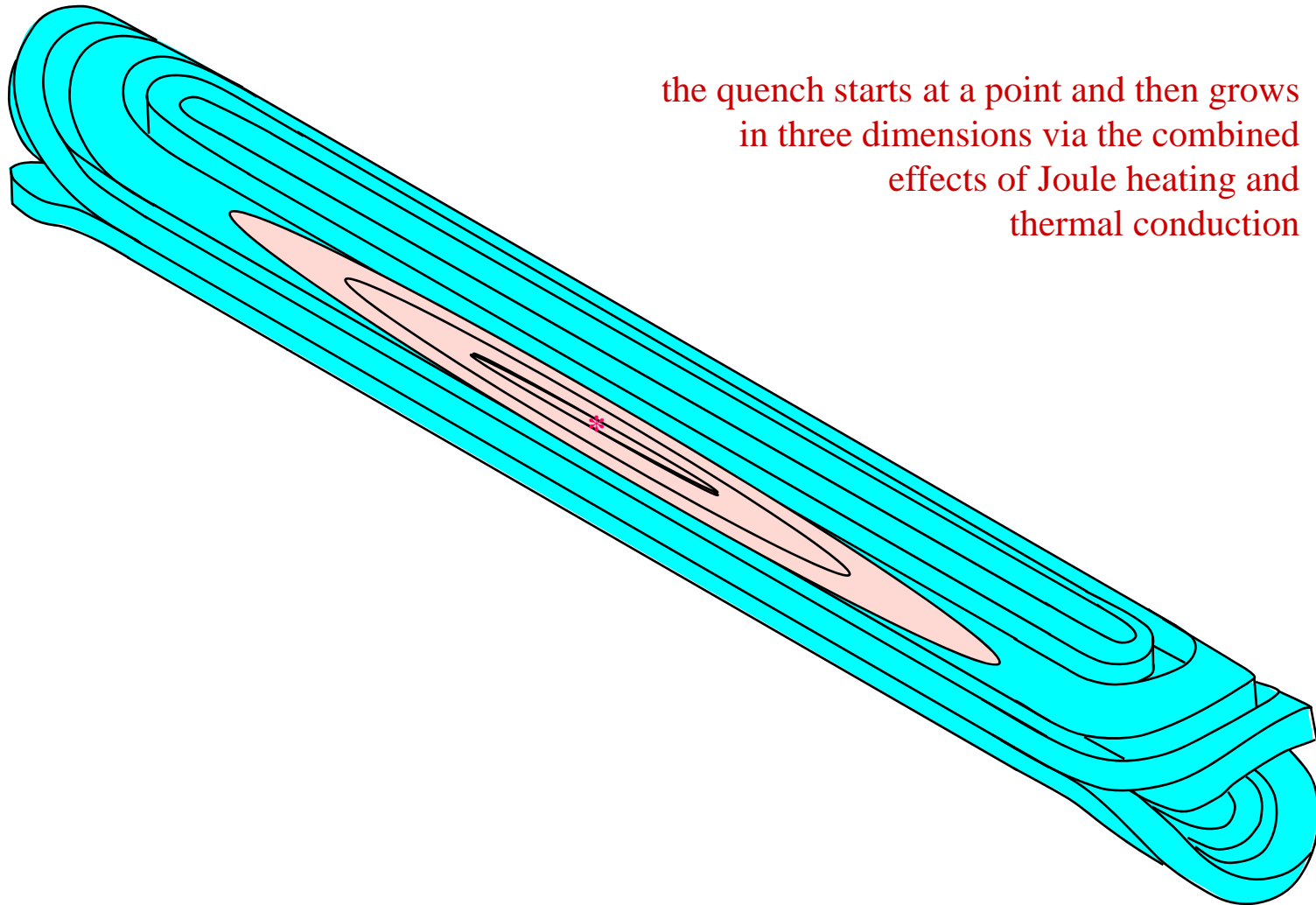

the quench starts at a point and then grows  
in three dimensions via the combined  
effects of Joule heating and  
thermal conduction



# Quench propagation velocity

- resistive zone starts at a point and spreads along the conductor and transverse to it
- the force driving it forward is the heat generation in the resistive zone, together with heat conduction along the wire

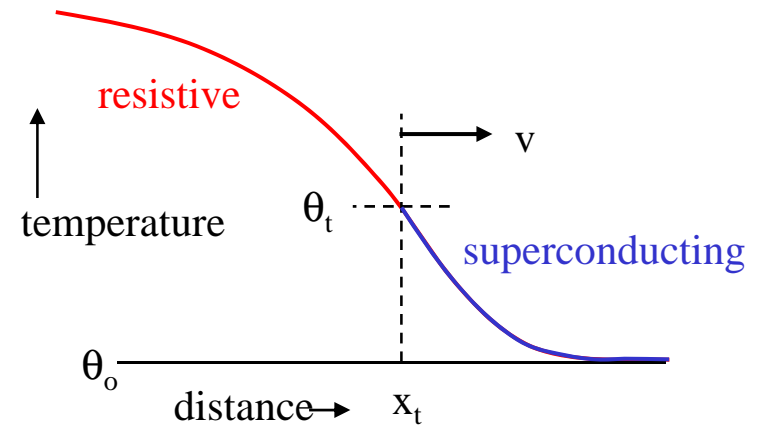

## Along the conductor

$$v_{long} = \frac{J}{\gamma C} \left\{ \frac{\rho k}{\theta_t - \theta_0} \right\}^{\frac{1}{2}}$$

where:  $J$  = engineering current density,  $\gamma$  = density,  $C$  = specific heat,  $\rho$  = resistivity,  $k$  = thermal conductivity,  $\theta_t$  = transition temperature

## Transverse to the conductor

$$\alpha = \frac{v_{trans}}{v_{long}} = \left\{ \frac{k_{trans}}{k_{long}} \right\}^{\frac{1}{2}}$$

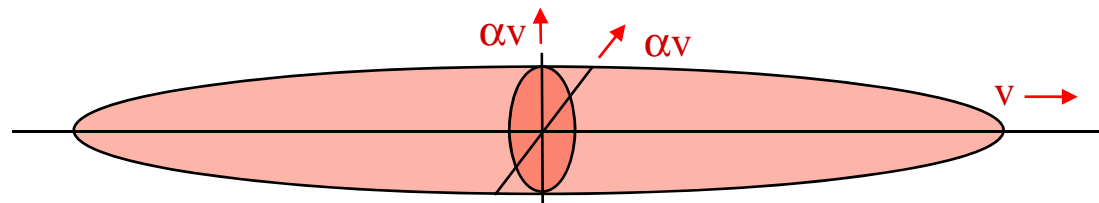

## Typical values

$$v_{ad} = 5 - 20 \text{ ms}^{-1} \quad \alpha = 0.01 - 0.03$$

# Computation of resistance growth and current decay

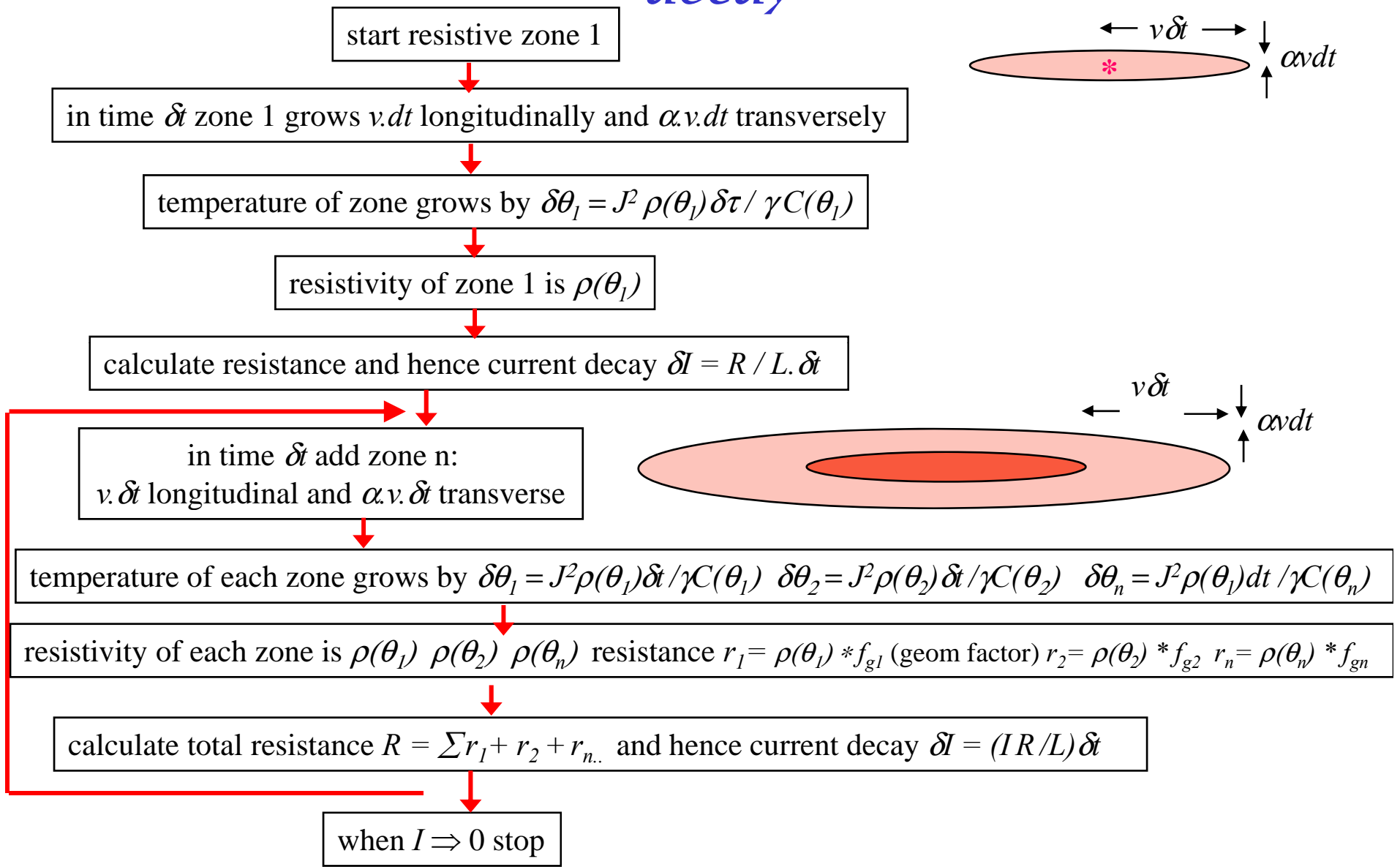

# Methods of quench protection:

## 1) External dump resistor

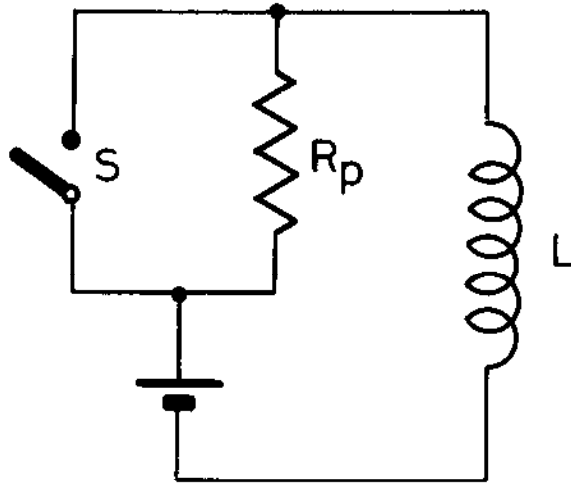

- detect the quench electronically
- open an external circuit breaker
- force the current to decay through the resistor

## 2) Quench back heater

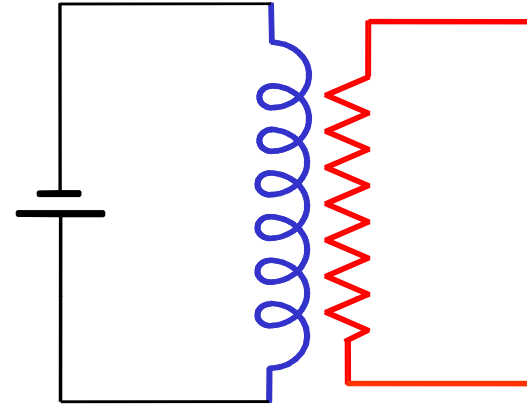

*method most commonly used in accelerator magnets ✓*

- detect the quench electronically
- power a heater in thermal contact with the winding
- this quenches other regions of the magnet, forcing the normal zone to grow more rapidly
  - ⇒ higher resistance
  - ⇒ shorter decay time
  - ⇒ lower temperature rise at the hot spot

# *Winding an LHC dipole*



*photo courtesy of Babcock Noell*



## *Curing press*

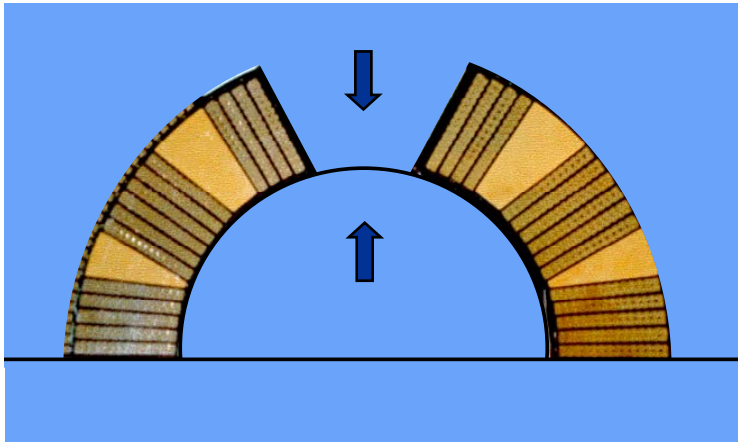

# Collars

How to make an external structure that

- fits tightly round the coil
  - presses it into an accurate shape
  - has low ac losses
  - can be mass produced cheaply
  - ???
- Answer make collars by precision stamping of stainless steel or aluminium alloy plate a few mm thick
- inherited from conventional magnet laminations

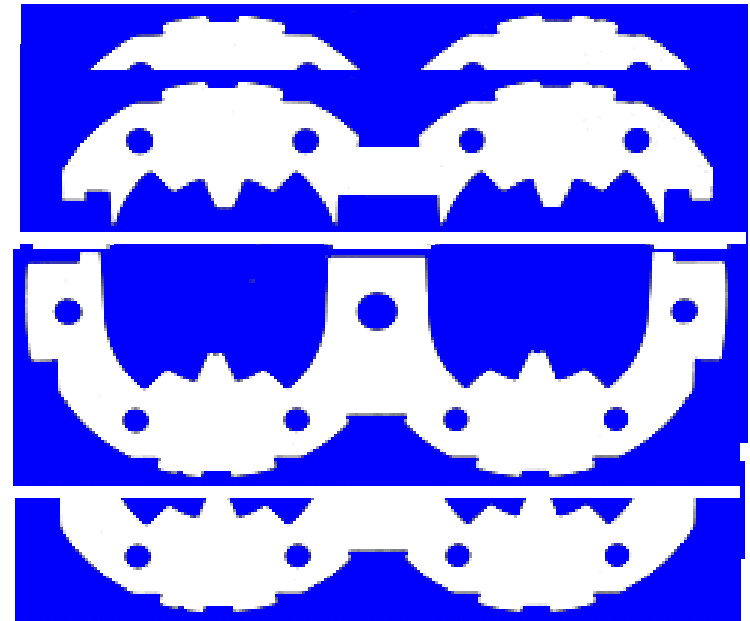

*press collars over coil from above and below*

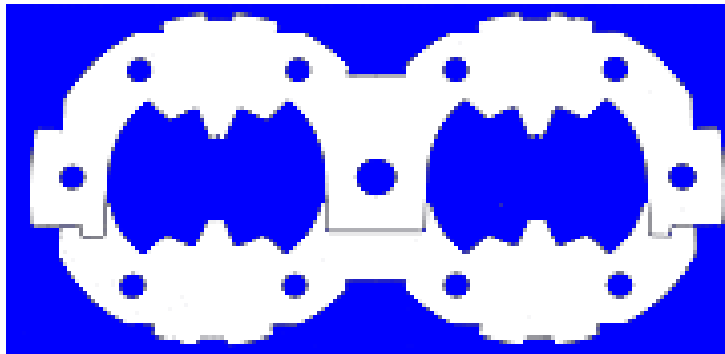

*invert alternate pairs so that they interlock*

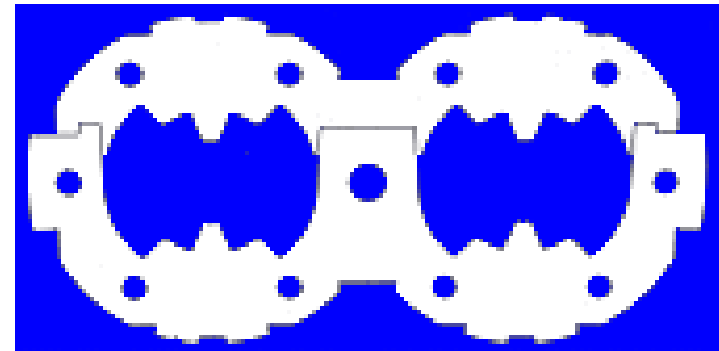

*push steel rods through holes to lock in position*

# Collars and end plate (LHC dipole)

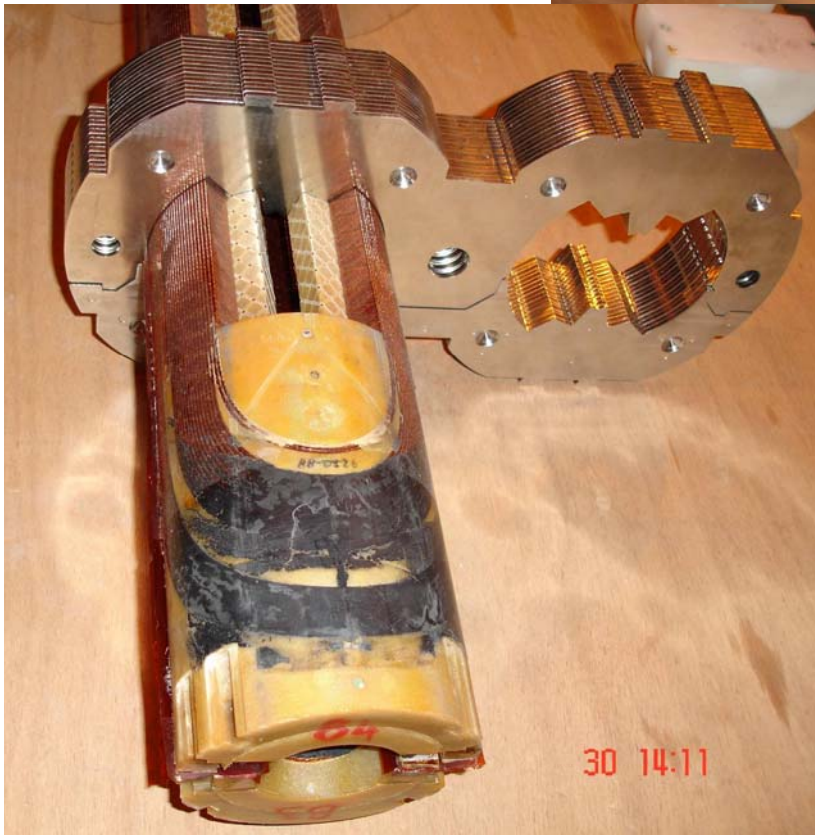



# Adding the iron

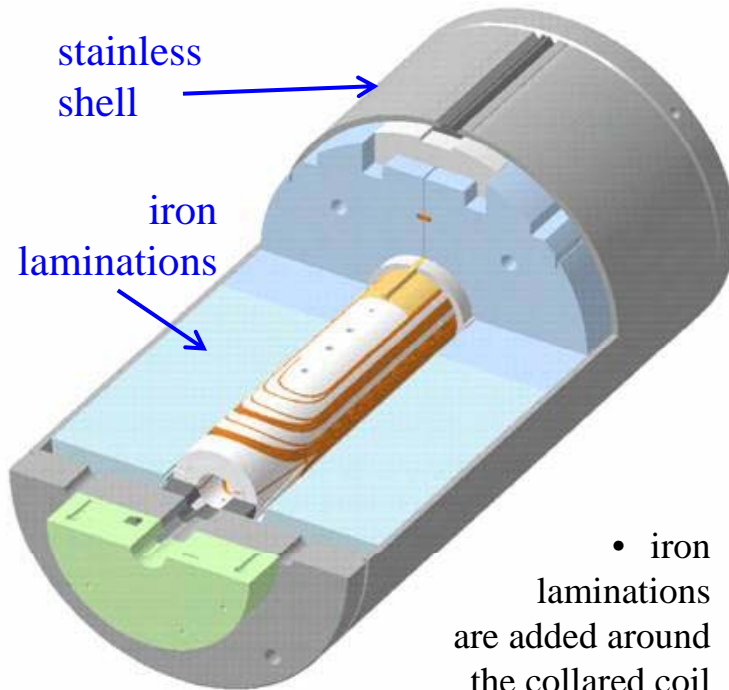

- iron laminations are added around the collared coil

- they are forced into place, again using the collaring press
- remember however that pure iron becomes brittle at low temperature
- the tensile forces are therefore taken by a stainless steel shell which is welded around the iron, while still in the press
- this stainless shell can also serve as the helium vessel

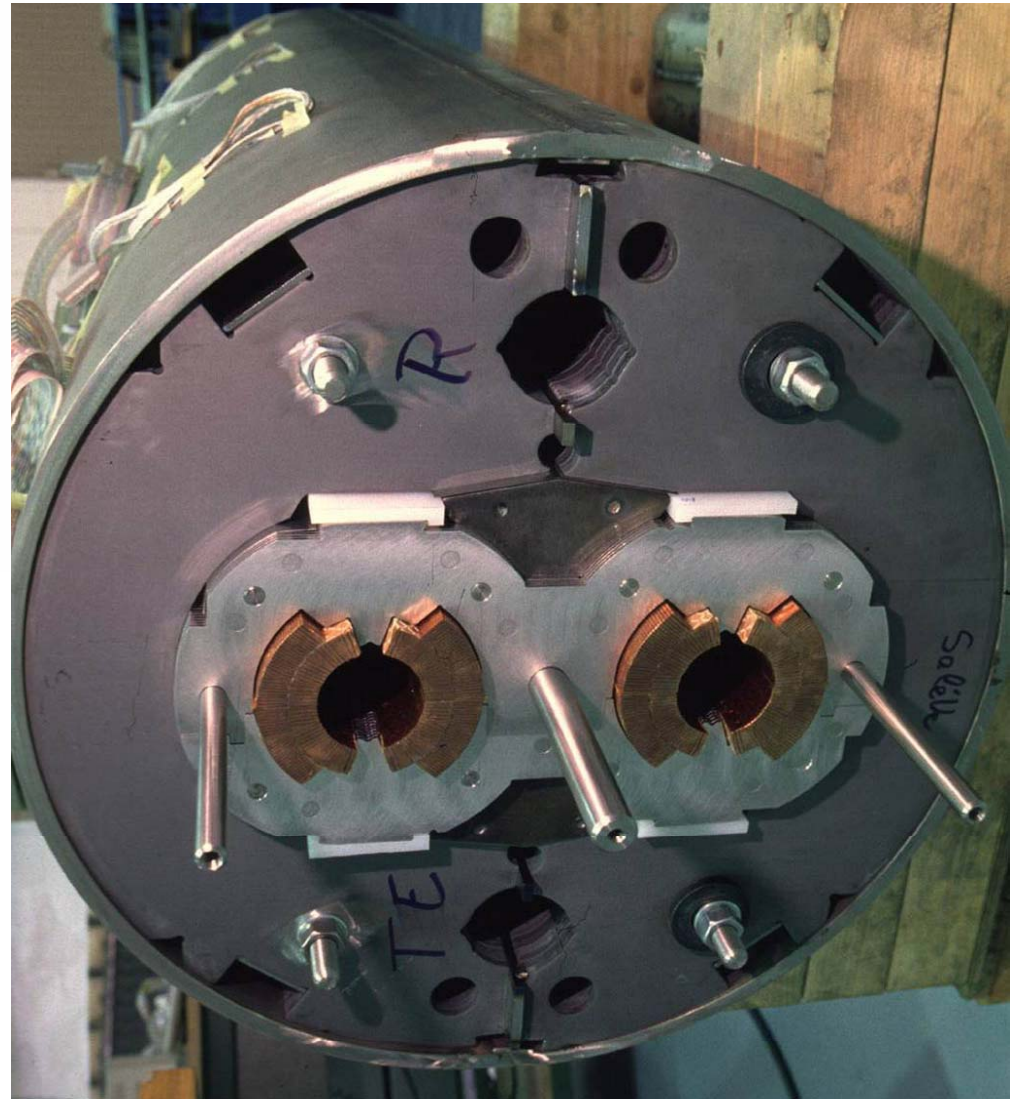

# *Dipole inside its stainless shell*

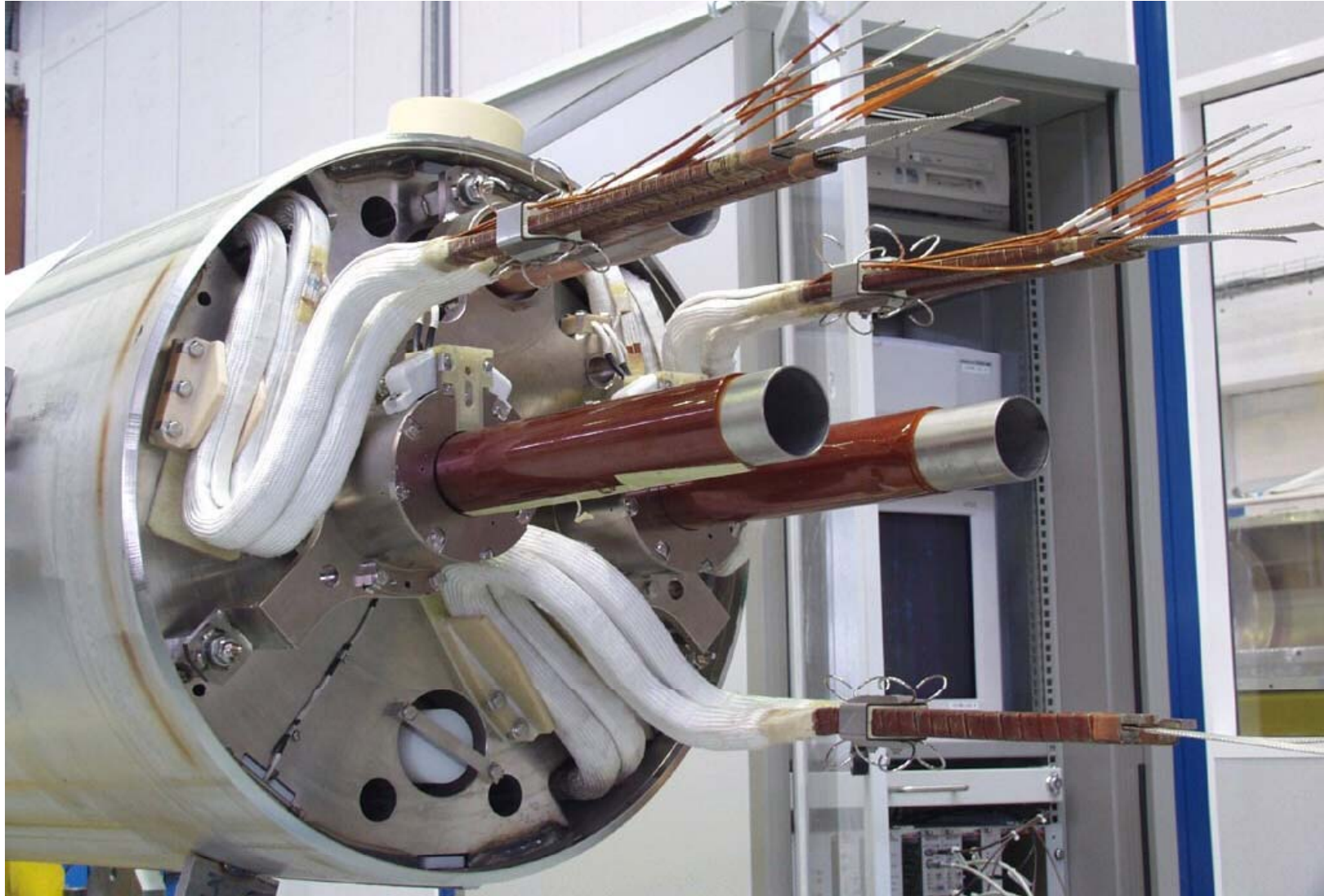



## *Complete magnet in cryostat*

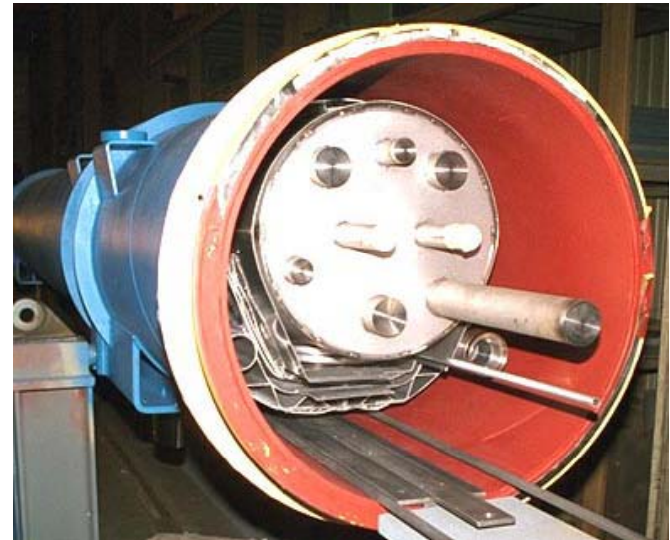

# *Make a lot of Magnets and install in the tunnel*

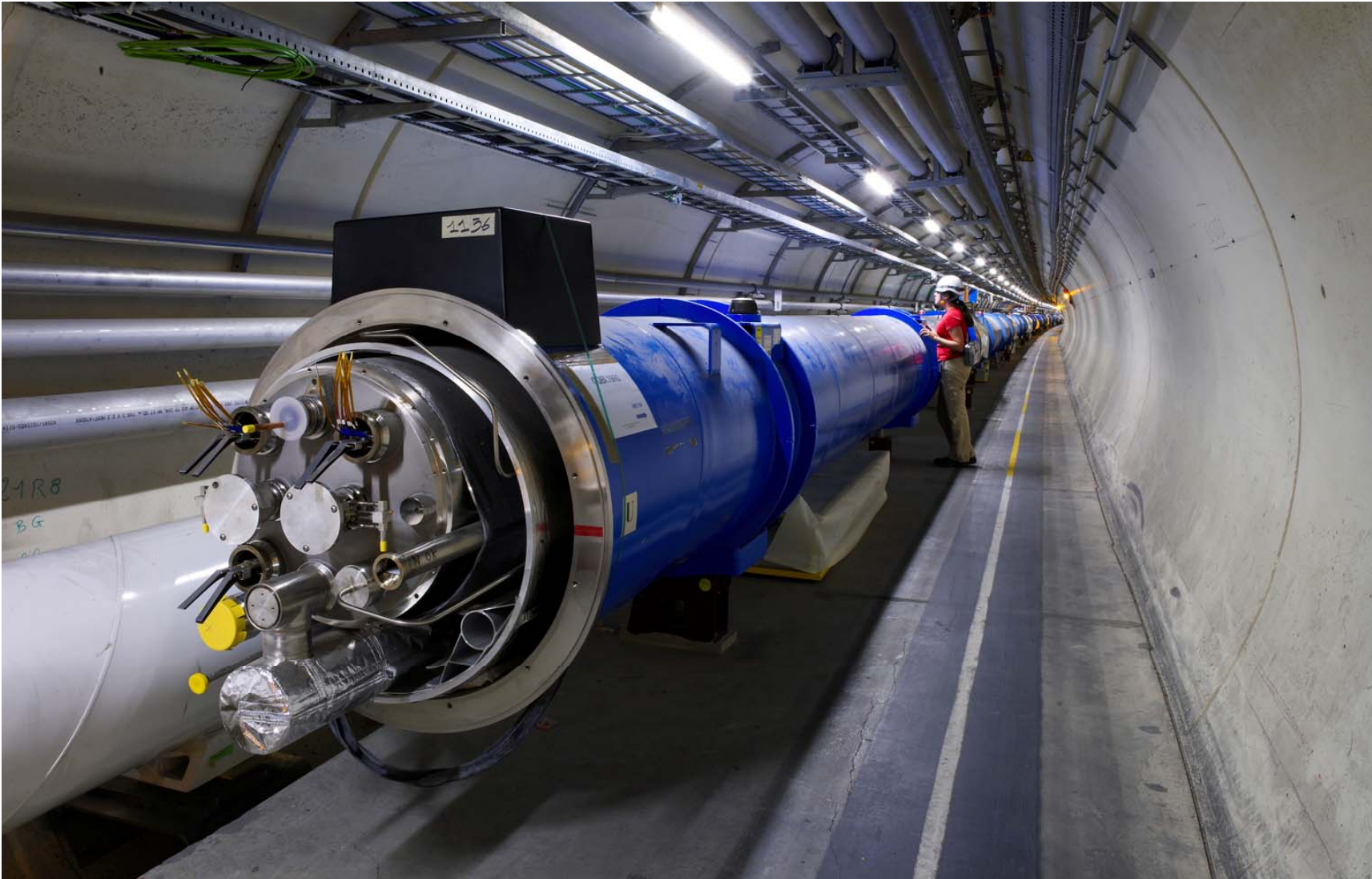

# Concluding remarks

- superconductivity offers higher magnetic fields and field gradients, with less energy dissipation
- NbTi is the most common superconducting material and has been used in all accelerators to date
- superconducting magnets do not use iron to shape the field, so must use special winding shapes
- magnets don't reach their expected current/field first time but show training
  - control training by reducing movement, attention to contraction and increasing MQE
- persistent screening currents produce magnetization of the superconductor which causes field errors and ac loss – need fine  $\sim 5\mu\text{m}$  filaments
- accelerators need high currents, so must use many wires in parallel – a cable
- coupling between filament in wire and between wires in cable increases magnetization
- magnets store large inductive energy which is released at quench as heating – must protect
- magnet manufacturing techniques have been developed to ensure accurate winding shape and minimize conductor movement

customer support: [m-wilson@dsl.pipex.com](mailto:m-wilson@dsl.pipex.com)



# Some useful references

## Superconducting Magnets

- Superconducting Accelerator Magnets: KH Mess, P Schmuser, S Wolf., pub World Scientific, (1996) ISBN 981-02-2790-6
- High Field Superconducting Magnets: FM Asner, pub Oxford University Press (1999) ISBN 0 19 851764 5
- Case Studies in Superconducting Magnets: Y Iwasa, pub Plenum Press, New York (1994), ISBN 0-306-44881-5.
- Superconducting Magnets: MN Wilson, pub Oxford University Press (1983) ISBN 0-019-854805-2
- Proc Applied Superconductivity Conference: pub as IEEE Trans Applied Superconductivity, Mar 93 to 99, and as IEEE Trans Magnetism Mar 75 to 91
- Handbook of Applied Superconductivity ed B Seeber, pub UK Institute Physics 1998
- JUAS lectures on superconducting magnets (and all accelerator topics) <http://juas.in2p3.fr>
- 'Superconducting Accelerator Magnets' DVD available from [mjball@comcast.net](mailto:mjball@comcast.net)

## Superconducting Materials

- Superconductor Science and Technology, published monthly by Institute of Physics (UK).
- Superconductivity of metals and Cuprates, JR Waldram, Institute of Physics Publishing (1996) ISBN 0 85274 337 8
- High Temperature Superconductors: Processing and Science, A Bourdillon and NX Tan Bourdillon, Academic Press, ISBN 0 12 117680 0

## Materials Mechanical

- Materials at Low Temperature: Ed RP Reed & AF Clark, pub Am. Soc. Metals 1983. ISBN 0-87170-146-4
- Handbook on Materials for Superconducting Machinery pub Batelle Columbus Laboratories 1977.
- Nonmetallic materials and composites at low temperatures: Ed AF Clark, RP Reed, G Hartwig pub Plenum
- Nonmetallic materials and composites at low temperatures 2, Ed G Hartwig, D Evans, pub Plenum 1982
- Austenitic Steels at low temperatures Editors R.P.Reed and T.Horiuchi, pub Plenum 1983

## Cryogenics

- Helium Cryogenics, Van Sciver SW, pub Plenum 86 ISBN 0-0306-42335-9
- Cryogenic Engineering, Hands BA, pub Academic Press 86 ISBN 0-012-322991-X
- Cryogenics: published monthly by Butterworths
- Cryogenie: Ses Applications en Supraconductivite, pub IIR 177 Boulevard Malesherbes F5017 Paris France
- Handbook of Cryogenic Engineering, ed JG Weisand, Taylor & Francis 1998 ISBN 1-56032-332-9
- Cryogenic Systems, RF Barron, Oxford Science Publications ISBN 0-19-503567-4



# Materials data web sites and software

[www.cryogenics.nist.gov](http://www.cryogenics.nist.gov) (free) thermal conductivity, specific heat, and thermal expansion of solids, have been empirically fitted and the equation parameters

[www.cpia.jhu.edu](http://www.cpia.jhu.edu) (charged) plots and automated data-look-up using the NIST equations

[www.cryodata.com](http://www.cryodata.com) (charged) cryogenic properties of about 100 materials.

[www.jahm.com](http://www.jahm.com) (charged) temperature dependent properties of about 1000 materials, many at cryogenic temperatures).

[www.matweb.com](http://www.matweb.com) (free) room-temperature data for 10 to 20 properties of about 24,000 materials

*thanks to Jack Ekin of NIST for this information*

[materialdatabase.magnet.fsu.edu](http://materialdatabase.magnet.fsu.edu) (free) structural materials at low temperature

[www.nist.gov/chemistry/fluid/](http://www.nist.gov/chemistry/fluid/) costs \$200 runs as dll from Excel, calculates thermophysical properties of fluids from the triple point upwards

**Software Products from [www.cryodata.com](http://www.cryodata.com)**  
**GASPAK**

properties of pure fluids from the triple point to high temperatures.

**HEPAK**

properties of helium including superfluid above 0.8 K, up to 1500 K.

**STEAMPAK**

properties of water from the triple point to 2000 K and 200 MPa.

**METALPAK, CPPACK, EXPAK**

reference properties of metals and other solids, 1 - 300 K.

**CRYOCOMP**

properties and thermal design calculations for solid materials, 1 - 300 K.

**SUPERMAGNET**

four unique engineering design codes for superconducting magnet systems.

**KRYOM**

numerical modelling calculations on radiation-shielded cryogenic enclosures.