

Emittance History (LHC-Design)

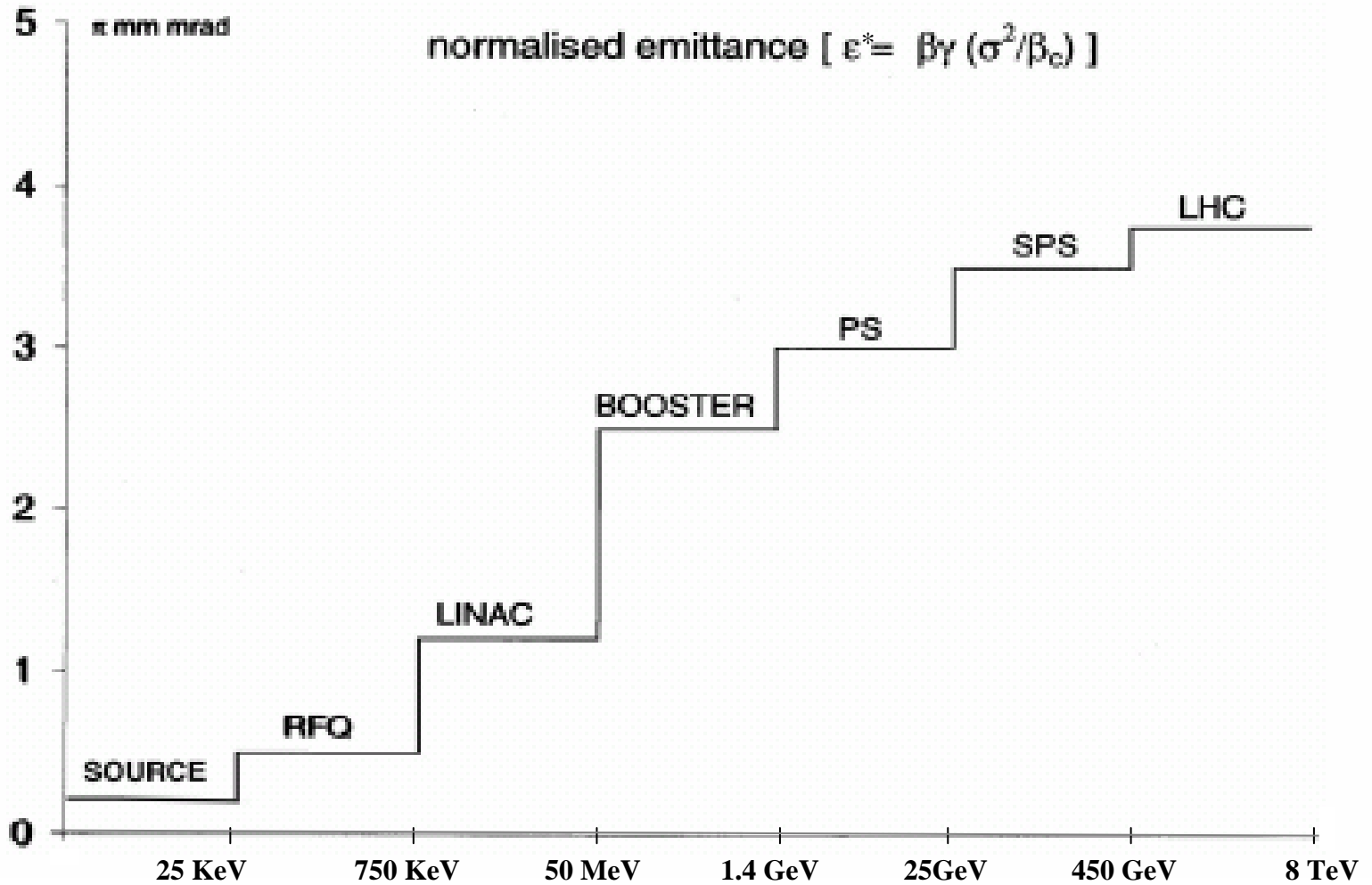

Sources of Emittance Growth

Dieter Möhl

Menu

- **Overview**
- **Definition of emittance , filamentation**
- **Mismatch at transfer**
- **Scattering on a foil**
- **Scattering on residual gas**
- **Intra-beam scattering**
- **Power supply noise and ripple**
- **Crossing resonances, instabilities**
- **Conclusions**



Emittance Definition

Betatron equation (linear!): $x(s)'' + K(s)x(s) = 0$

Solution for particle "i":

$$x = A_i \sqrt{\beta} \cos(\psi + \delta_i)$$

$$x' = -A_i \sqrt{1/\beta} \{ \alpha \cos(\psi + \delta_i) + \sin(\psi + \delta_i) \}$$

$$\psi(t) = \int ds / \beta(s)$$

$$\alpha = -\frac{1}{2} \beta', \quad \gamma = (1 + \alpha^2) / \beta$$

or :

$$x = A_i \sqrt{\beta} \cos(\psi + \delta_i)$$

$$p_x = \alpha x + \beta x' = -A_i \sqrt{\beta} \sin(\psi + \delta_i)$$



Single Particle (x x')-Phase-Space Trajectory

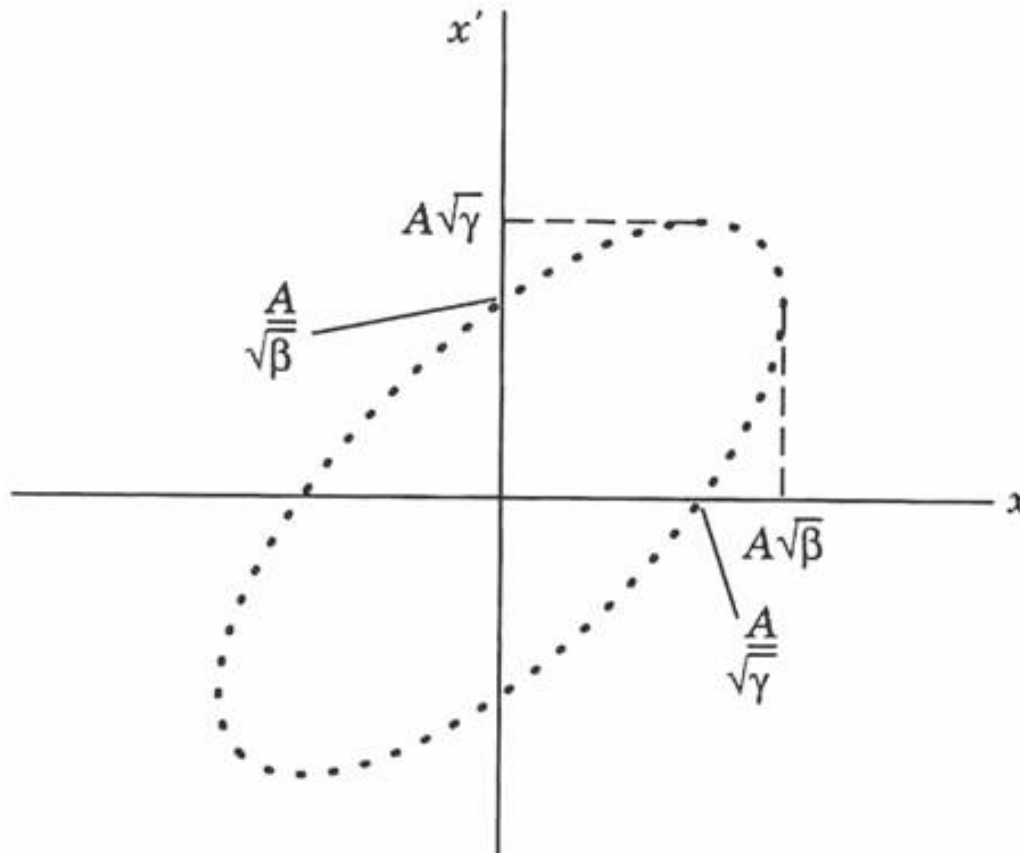

Area of ellipse: $\pi x_{\max}^2 / \beta = \pi x_{\max}^{\prime 2} \gamma$: ‘single particle emittance’
(also called : Courant&Snyder –invariant)

Change of phase space trajectories along a beam channel

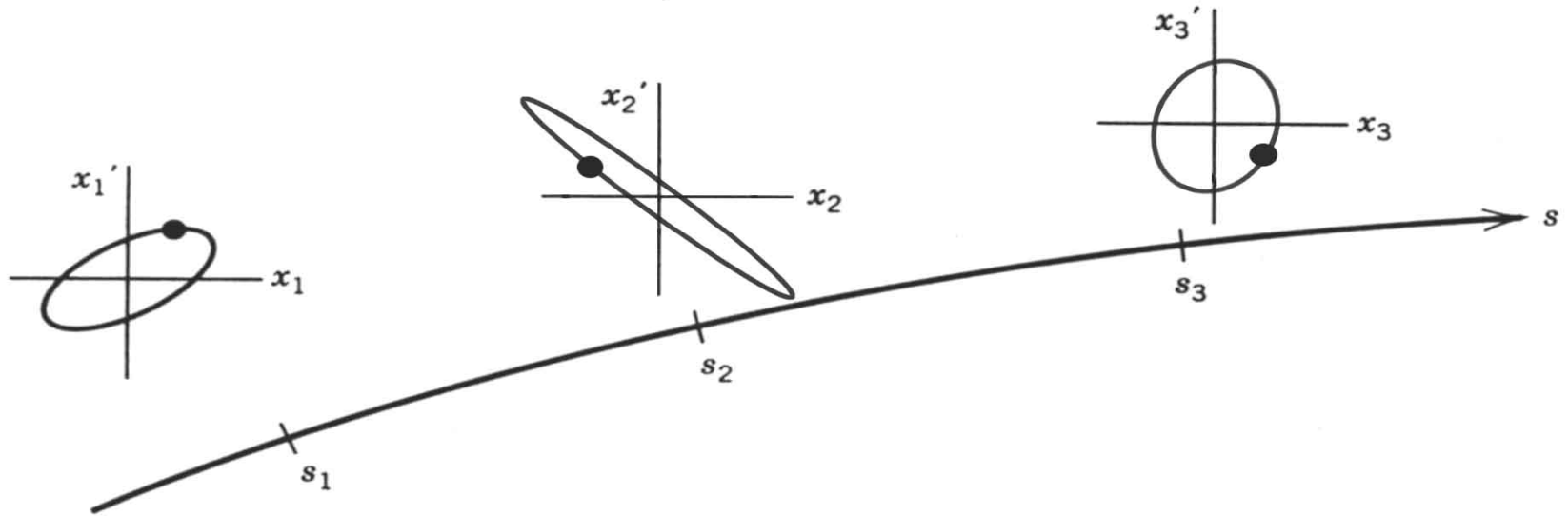

As the beta function changes along the channel (line, ring...) the ellipse pattern strongly varies. But the area of the ellipses is the same (as a consequence of Liouville's theorem) .

Single particle trajectory in normalized (circular) phase-space

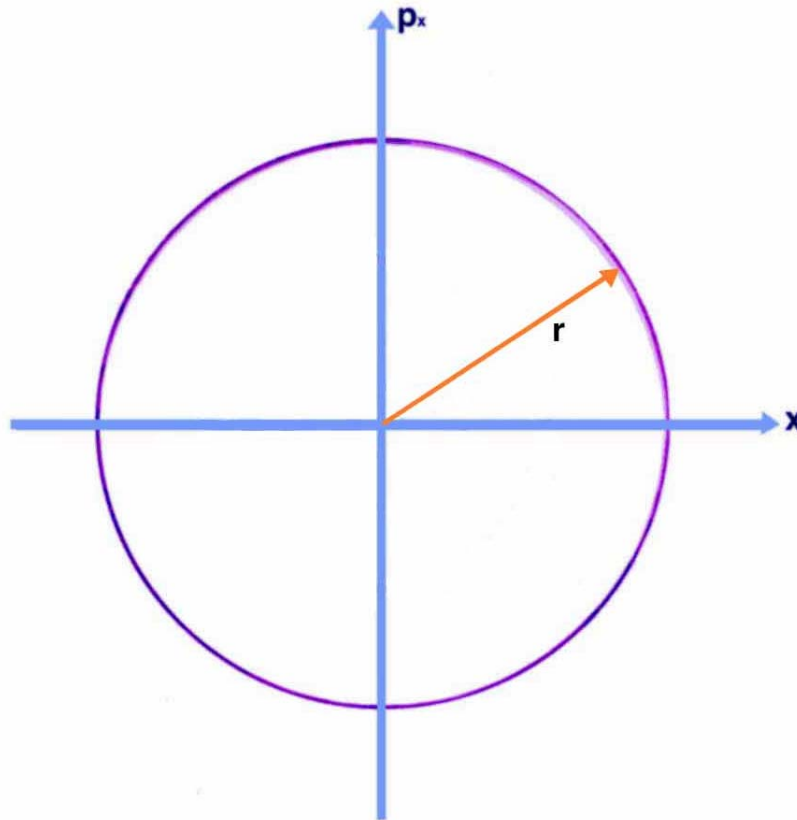

Area of circle: ‘single particle emittance’

Many particle trajectories and projected density

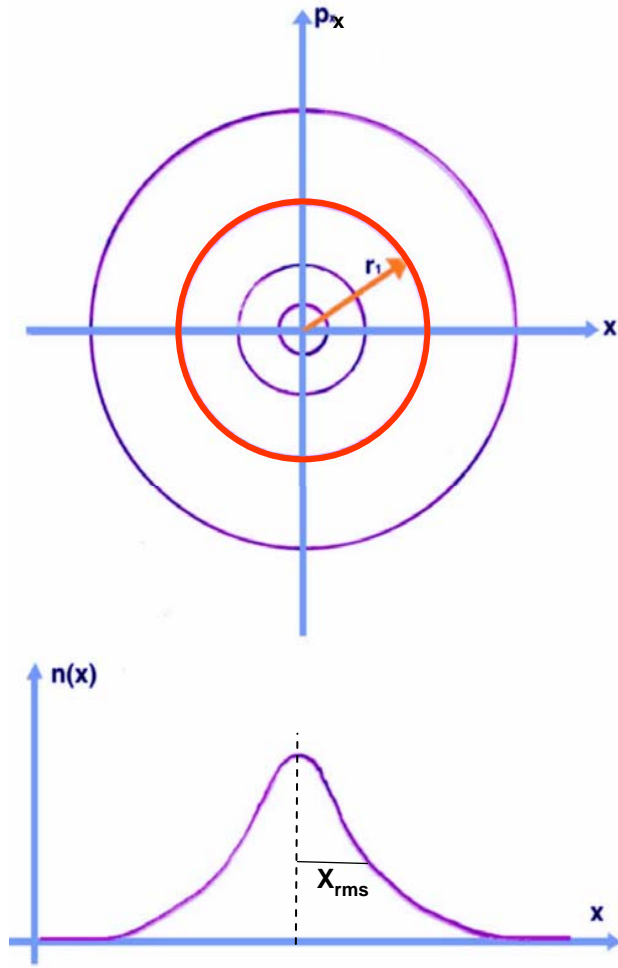

Beam emittance =
“average” of ϵ_i over all beam particles

“geometrical emittance”: area of the circle that contains a given fraction (F) of the particles

“rms emittance”: area of the circle with radius $\sigma_x = X_{rms}$

Two beam emittance definitions

Definition referring to the a fixed fraction of particles:

The beam emittance ($\varepsilon_{\%}$) is the area of the circle in (x, p_x) space that contains the motion of a given fraction (F) of the particles. Usually one refers to $F = 39\%$ or 86% or 95%

$\varepsilon_{\%}$ is (sometimes) called: “geometrical emittance”

Definition referring to the standard deviation of the projected distribution:

Let σ_x be the standard deviation of the particle density projected on the x-axis (i.e. the "rms beam size" as measured e.g. on a profile detector). Then the emittance ($\varepsilon_{k\sigma}$) is defined as the area in (x, p_x) space with radius $k\sigma_x$. Usually one chooses $k=1$ or 2 or 2.5 .

$\varepsilon_{k\sigma} = (k\sigma)^2/\beta$ is called “ ‘k’-rms emittance “



Filamentation

Nonlinearity of betatron oscillation causes a dependence of frequency on amplitude ---> particles go around in phase space at (slightly) different speed. Over sufficiently long time a mismatched beam 'smears out' and the larger phase space becomes filled out.

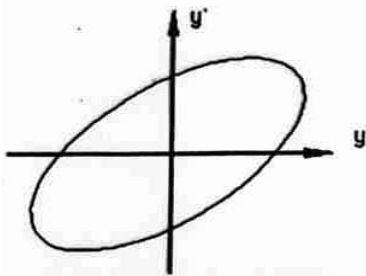

(a) Form of matched ellipse

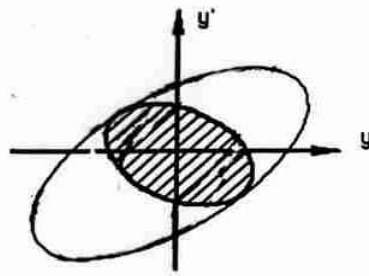

(b) Unmatched beam

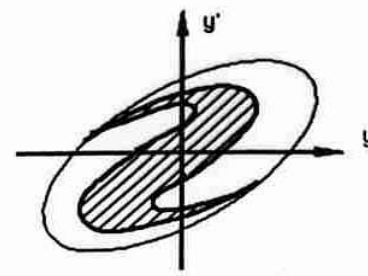

(c) Filamenting beam

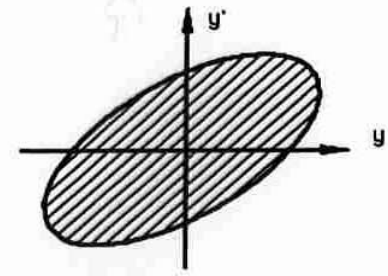

(d) Fully filamented beam

**Filamentation = Randomisation of betatron phases in a mismatched beam
---> emittance dilution (apparent blow up)**

Simulation of filamentation after injection error

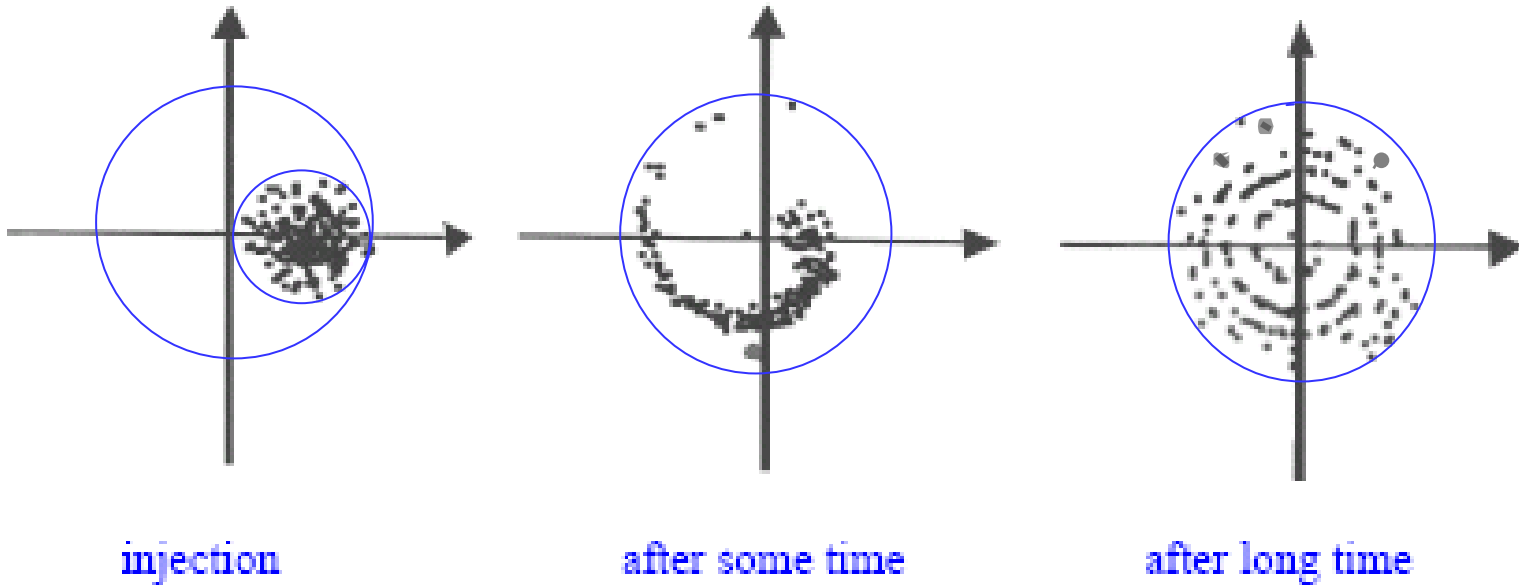

Injection error

Suppose the beam is injected with displacement Δx and angular error $\Delta x'$ into an otherwise matched phase space.

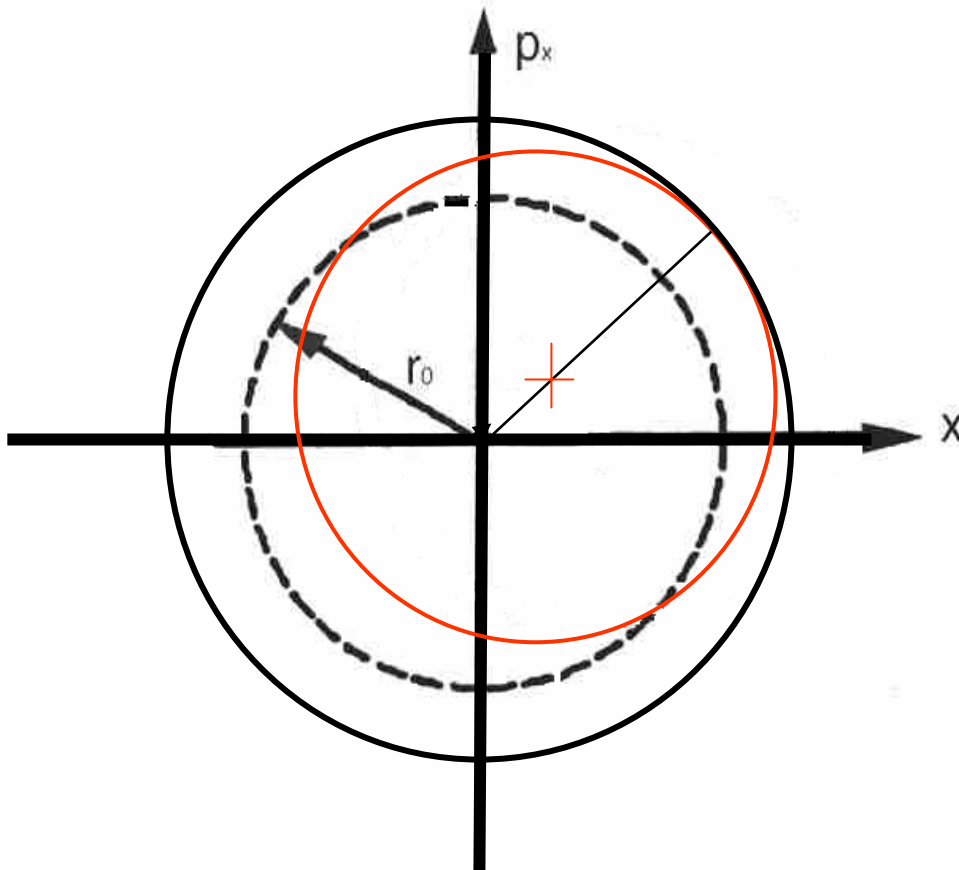

Circumscribed circle, radius
 $r_0 + \Delta r$

Injection error

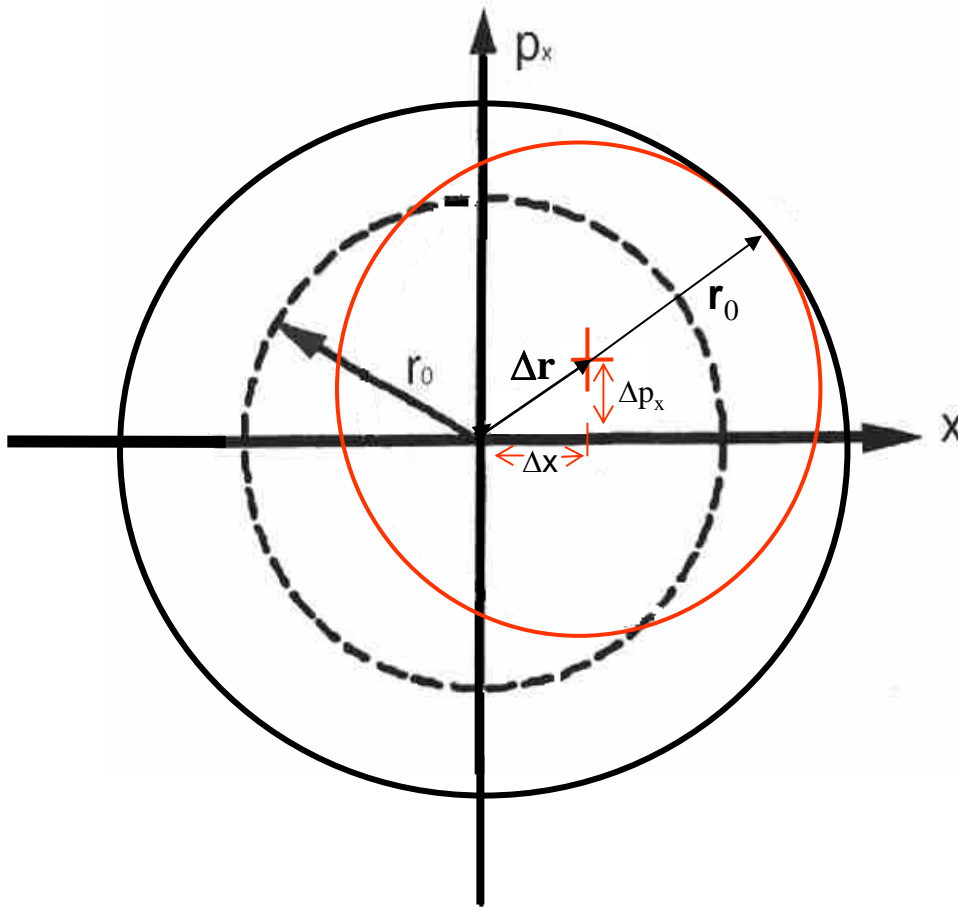

$$r_0 \rightarrow r_0 + \Delta r$$

The emittance containing the given fraction of particles increases to:

$$\varepsilon_{\%} \rightarrow \varepsilon_{\%} (1 + \Delta r / r_0)^2$$

Note that

$$\Delta r = \{ \Delta x^2 + (\beta \Delta x' + \alpha \Delta x)^2 \}^{1/2}$$

Injection error, increase of rms-emittance

Assume (again) the beam is injected with an error $\{ \Delta x, \Delta p_x \}$

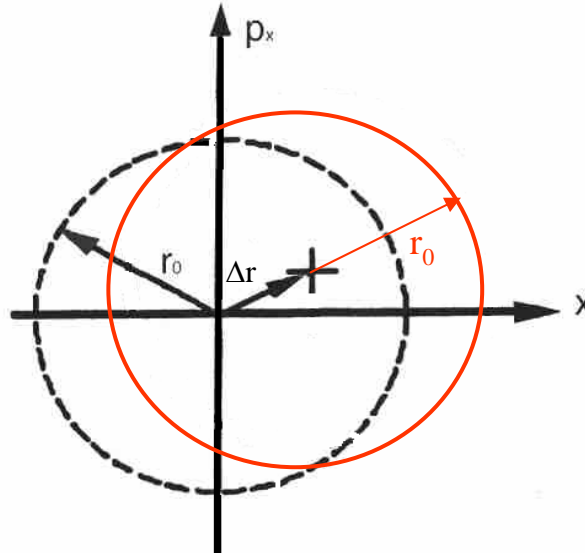

By geometrical arguments one finds that after filamentation the beam has the new

$$\sigma^2 = \sigma_0^2 + 1/2 \Delta r^2$$

$$\varepsilon_{k\sigma} \rightarrow \varepsilon_{k\sigma} \left\{ 1 + 1/2 (\Delta r^2 / \sigma_{x0}^2) \right\}$$

Distribution after filamentation of an injection error

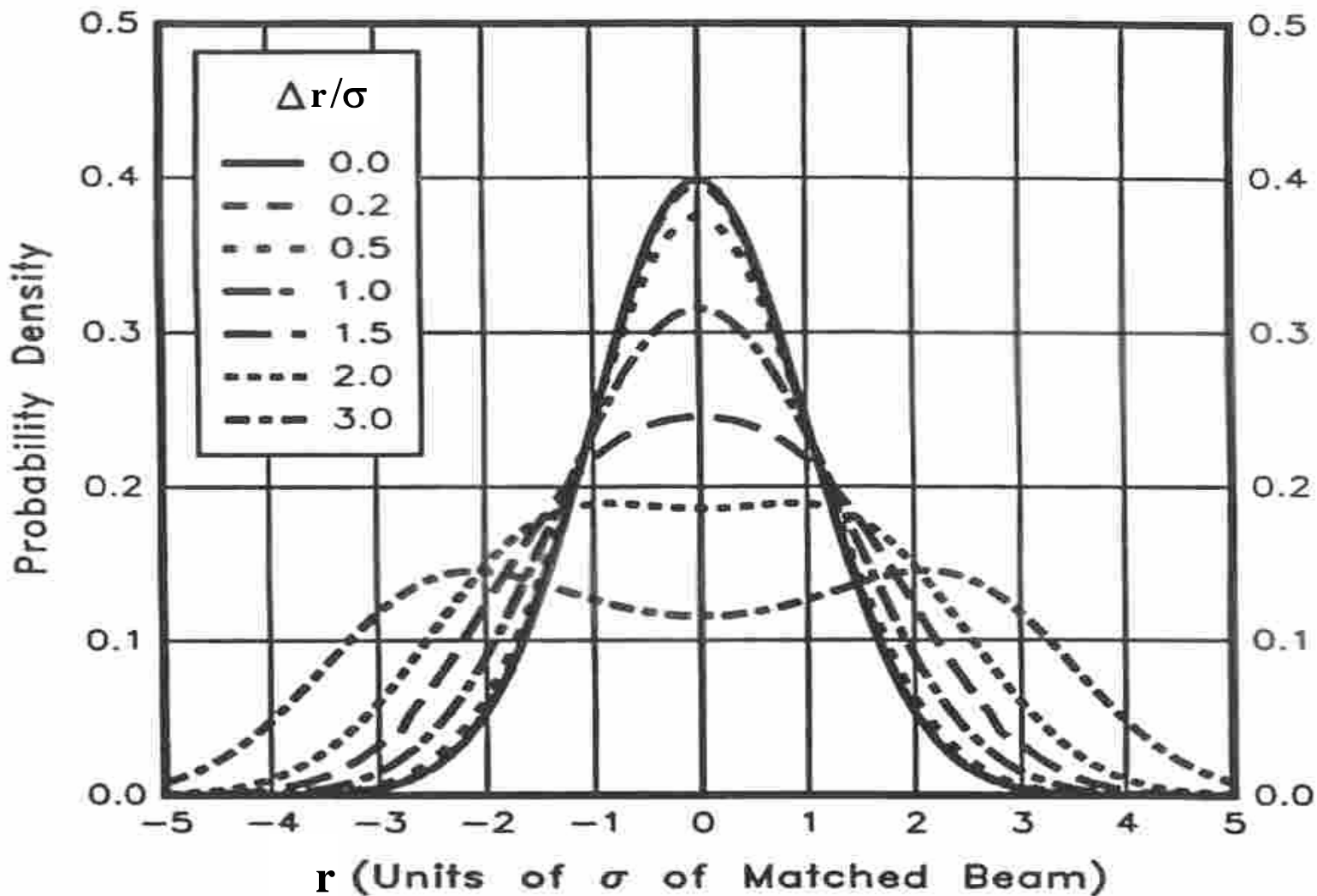

Large steering error, situation after filamentation

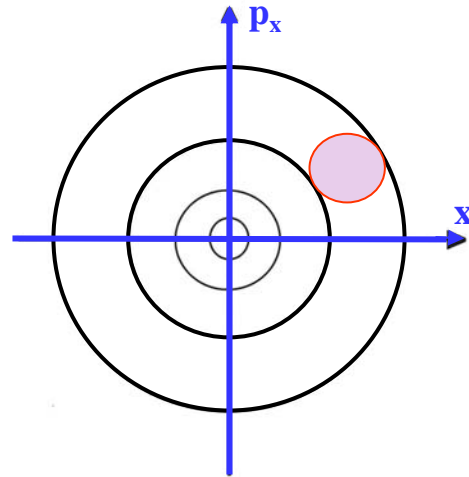

The beam injected with large steering error ‘smears out’ over the annular region. The resulting projected distribution is ‘double humped’.

Steering error, antidotes

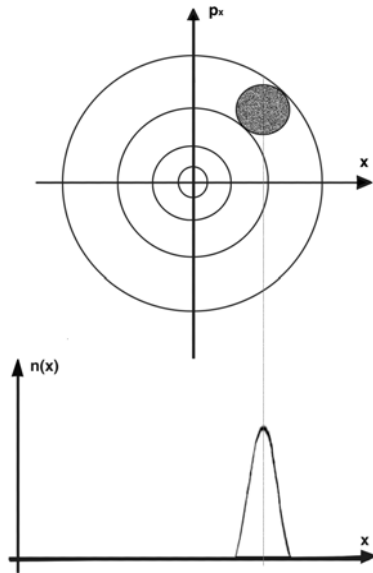

(1)

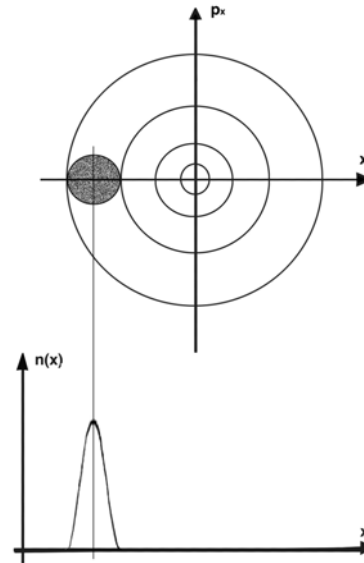

(2)

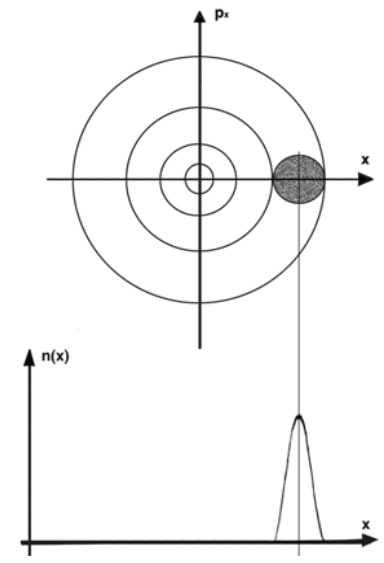

(3)

The error can be damped by a feedback system (if filamentation is slow)

Momentum error

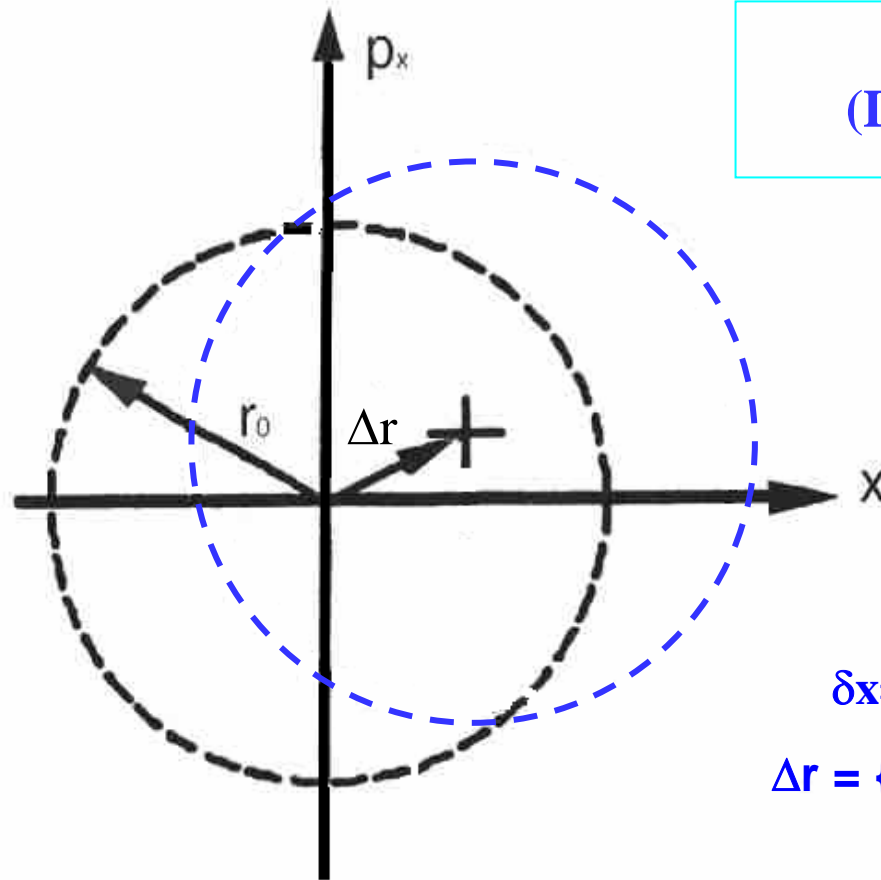

assumed
 $(D, D')_{\text{line}} = (D, D')_{\text{ring}} !$

$$\delta x = D \delta p/p, \quad \delta x' = D' \delta p/p$$

$$\Delta r = \{ \delta x^2 + (\beta \delta x' + \alpha \delta x)^2 \}^{1/2}$$

$$\Delta r = \{ D^2 + (\beta D' + \alpha D)^2 \}^{1/2} \delta p/p,$$

Dispersion function error ($D_{\text{ring}}=D_{\text{line}}+\Delta D$)

Without loss of generality assume that the machine has zero and the line has finite D ; in the general case we just can substitute $D \rightarrow \Delta D$). The β and β' -functions are matched. Then for any particle

$$x = r \cos(\Psi) + D \Delta p/p, \quad p_x = r \sin(\Psi) + (\beta D' + \alpha D) \Delta p/p$$

For any $\Delta p/p$ the phases are uniformly distributed around the off momentum orbit with its centre displaced by $\Delta r = \{ D^2 + (\beta D' + \alpha D)^2 \}^{1/2} \Delta p/p$

$$2 \sigma^2 = \langle x^2 + p_x^2 \rangle = \langle r^2 + \{ D^2 + (\beta D' + \alpha D)^2 \} (\Delta p/p)^2 \rangle$$

After filamentation when phases are uniformly distributed around $\Delta r=0$

$$\sigma^2 = \sigma_0^2 + 1/2 \{ D^2 + (\beta D' + \alpha D)^2 \} (\sigma_p/p)^2$$

$$\varepsilon_{k\sigma} \rightarrow \varepsilon_{k\sigma} \{ 1 + 1/2 \{ (\Delta D)^2 + (\beta \Delta D' + \alpha \Delta D)^2 \} (\sigma_p/p)^2 / \sigma_0^2 \}$$

Focussing error (mismatch) at transfer

Suppose the line (β, β') - functions differ from the ring ones . Normalising the ring phase space to circles, the trajectories of the mismatched injected beam are ellipses (area $\sim a*b$). Particles contained in a given ellipse fill, after filamentation, the circumscribed circle of the ring phase space with an area increase (major/minor axis)

$$\epsilon_{\%} \rightarrow \epsilon_{\%} (b/a)$$

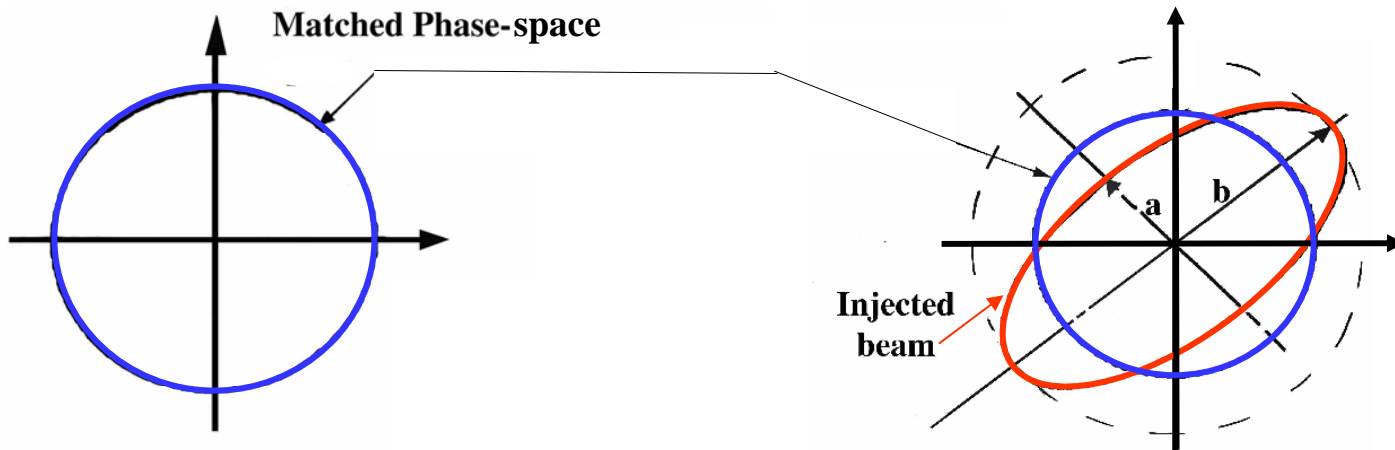

This can be expressed as

$$\epsilon_{\%} \rightarrow \epsilon_{\%} \left(F + \sqrt{F^2 - 1} \right) \quad \text{where } F = \frac{1}{2} \left(\frac{\beta_l}{\beta_r} + \frac{\beta_r}{\beta_l} + \left(\frac{\alpha_r}{\beta_r} - \frac{\alpha_l}{\beta_l} \right)^2 \beta_r \beta_l \right)$$

Focussing error at transfer, increase of r.m.s emittance

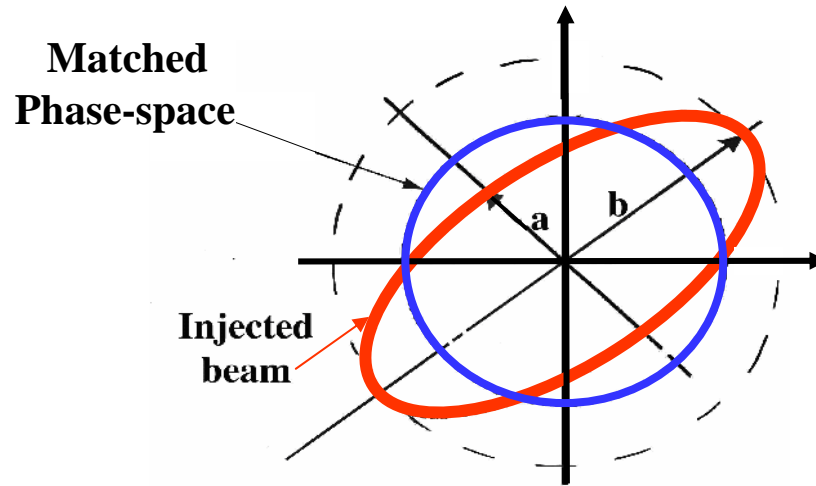

The increase in r.m.s. emittance can be shown to be

$$\varepsilon_{k\sigma} \rightarrow \varepsilon_{k\sigma} \frac{(b/a + a/b)}{2}$$

Or equivalently

$$\varepsilon_{k\sigma} \rightarrow \varepsilon_{k\sigma} F$$

Matching conditions, recapitulation

At transfer from one machine to the next one has to match

6 quantities for each transverse plane:

- Beam position
- Beam angle

- Beta function
- Derivative of beta function

- Dispersion
- Derivative of dispersion

In addition the energy has to be adjusted correctly



Recapitulation and example

	Steering error ($\Delta r^2/\beta\varepsilon = 0.1$)	Mismatch ($F=1.1$)
<p style="text-align: center;"><u>Blow up $\varepsilon_{\%}/\varepsilon_{\%,0}$ of geometrical emittance</u></p> <p style="text-align: center;">general</p> <p style="text-align: center;">example</p>	$\left(1 + \sqrt{\frac{\Delta r^2}{\beta_x \varepsilon_{\%}}} \right)^2$ <p>1.73</p>	$\left(F + \sqrt{F^2 - 1} \right)$ <p>1.56</p>
<p style="text-align: center;"><u>Blow up $\varepsilon_{rms}/\varepsilon_{rms,0}$ of rms-emittance</u></p> <p style="text-align: center;">general</p> <p style="text-align: center;">example</p>	$\left(1 + \frac{1}{2} \frac{\Delta r^2}{\beta_x \varepsilon_{rms}} \right)$ <p>1.05</p>	<p>F</p> <p>1.1</p>

$$\Delta r = \sqrt{(\Delta x)^2 + (\alpha_x \Delta x + \beta_x \Delta x')^2}$$

$$F = \frac{1}{2} \left(\frac{\beta_l}{\beta_r} + \frac{\beta_r}{\beta_l} + \left(\frac{\alpha_r}{\beta_r} - \frac{\alpha_l}{\beta_l} \right)^2 \beta_r \beta_l \right)$$



Mismatch due to nonlinearity (space-charge)

Nonlinearity distorts the phase space (example given in the picture).
Space-charge introduces linear and nonlinear detuning. Even if the linear term is compensated, matching to the nonlinear pattern is difficult.
---> blow up at injection into space-charge limited machines

Phase space in the presence
of a 3-rd order nonlinearity.
Innermost trajectory of the
stable area are normalized
to circular shape

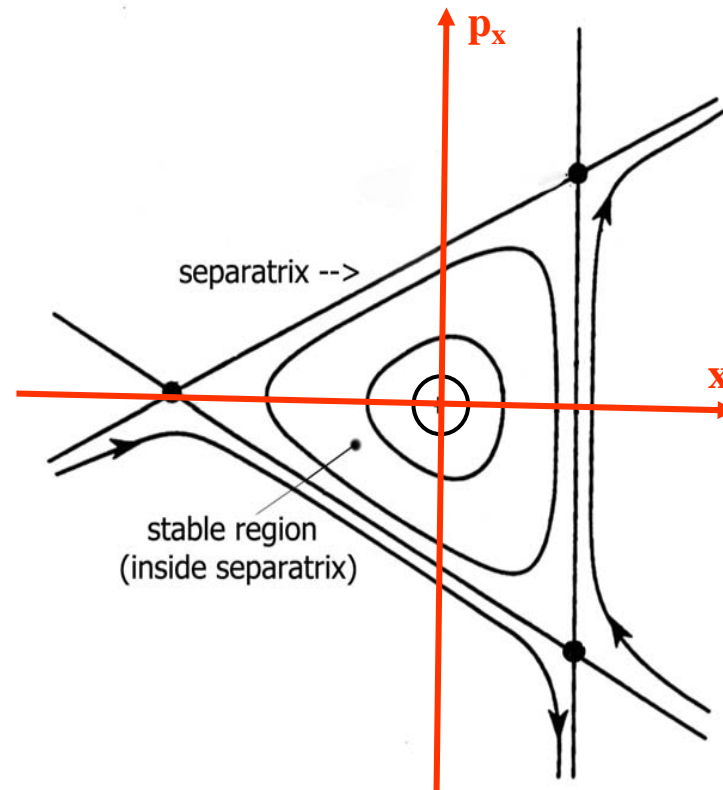

Emittance History (LHC-Design)

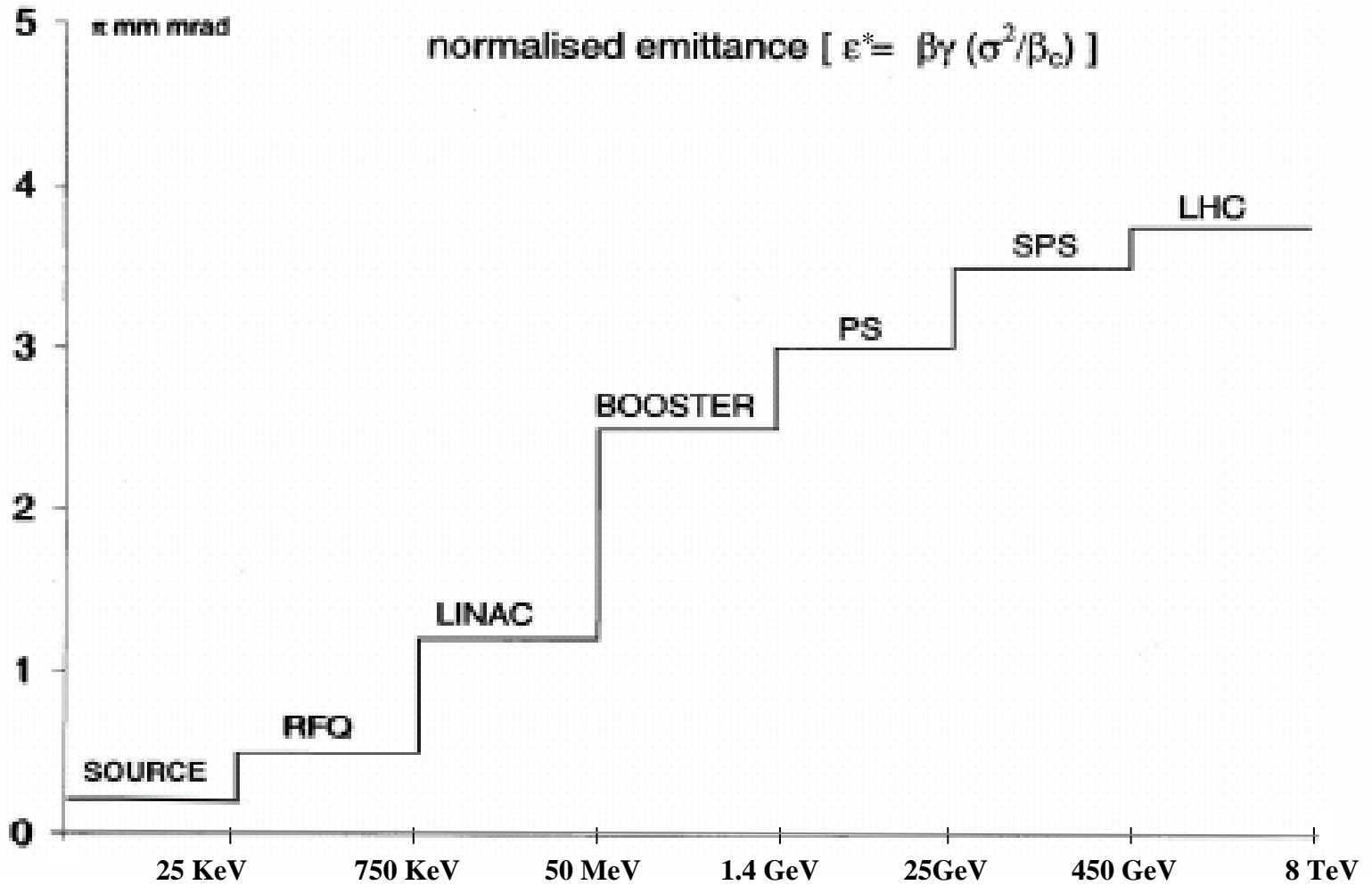

Transition through a foil

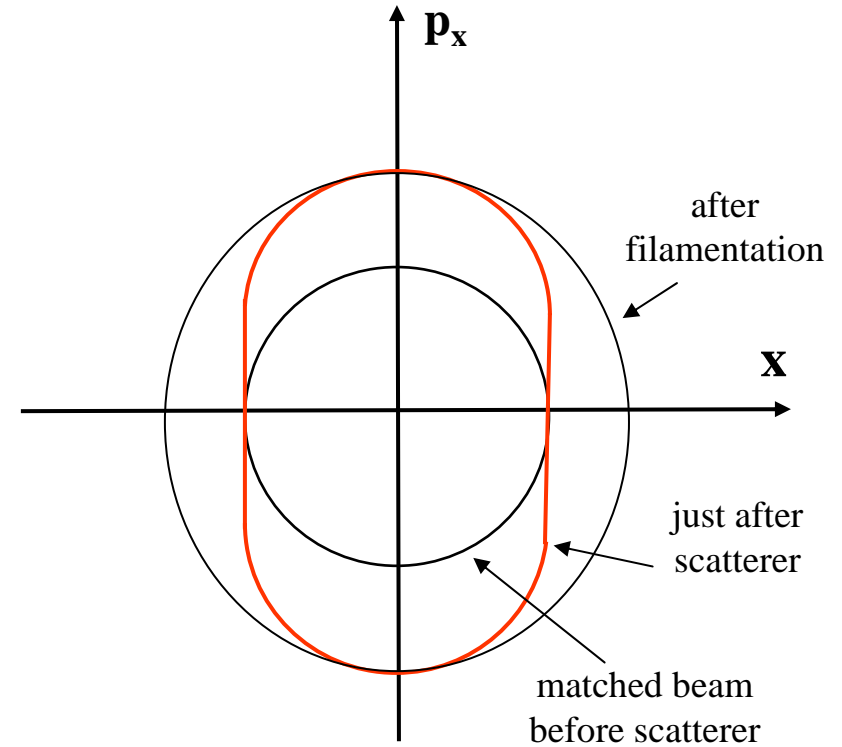
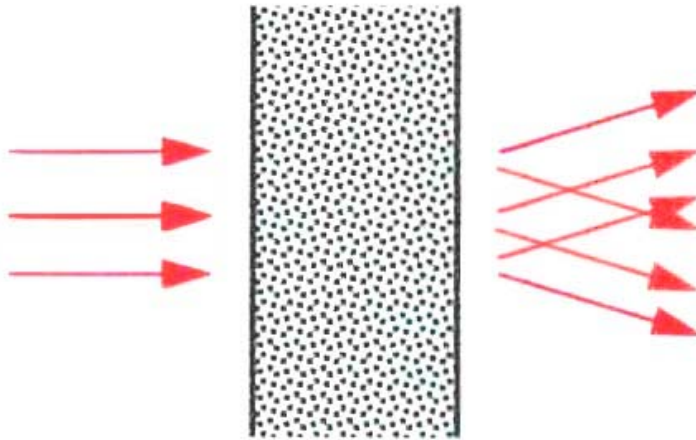

$$\theta_{rms} = \frac{14 \text{ MeV}/c}{p\beta} q \sqrt{\frac{L}{L_{rad}}}$$

$$\Delta\epsilon_{\sigma} = \frac{1}{2} \theta_{rms}^2 \beta_x$$

Multiple Coulomb scattering on the residual gas

This is treated in many papers of which I find the one by W. Hardt (CERN ISR-300/GS/68-11) especially instructive. We can use our previous results immediately **by taking the residual gas atmosphere as a "thin distributed scatterer"**.

For Nitrogen (N₂) at pressure P the radiation length is $L_{rad} \approx 330 \text{ m} / (P/760 \text{ torr})$ and the thickness traversed by the beam in time t is $L = \beta c t$. Then from the scattering blow up (Eq. of the previous slide) we get the blow-up of the σ -emittance (Hardt's formula) as

$$\Delta \varepsilon_{\sigma} \approx 0.14 \frac{q^2}{A^2} \bar{\beta}_x \frac{P}{\beta^3 \gamma^2} t$$

For an atmosphere with different gases of partial pressures P_i we can define the N₂ equivalent P for multiple Coulomb scattering as $P_{N2equ} = \sum P_i (L_{rad,N2} / L_{rad,i})$

For a synchrotron one has to integrate $d(\Delta \varepsilon \beta \gamma) = 0.14 \frac{q^2}{A^2} \bar{\beta}_x \frac{P}{\beta^2 \gamma} dt$ over the acceleration cycle to get the blow up of the normalised emittance.



Hardt's classical internal paper (ISR-300/GS/68-11)

EUROPEAN ORGANIZATION FOR NUCLEAR RESEARCH

ISR-300/GS/68-11

A FEW SIMPLE EXPRESSIONS FOR CHECKING VACUUM REQUIREMENTS
IN A PROTON SYNCHROTRON

by

W. Hardt

Geneva - 14 March, 1968



Influence of the residual gas, orders of magnitude

In **LEAR** the vacuum pressure (N₂ equivalent for scattering) is of the order of **P=10⁻¹² torr**.
Then: $L_{\text{rad}} = 2.3 \cdot 10^{17} \text{ m}$ (about 25 light years).

At **p=100 MeV/c** ($\beta \approx 0.1$) an rms scattering angle of $\theta_{\text{rms}} = 5 \cdot 10^{-3} \text{ rad}$ for (anti)protons is reached after a path length $L = 1.3 \cdot 10^{-5} \times L_{\text{rad}} = 3 \cdot 10^{12} \text{ m}$ (about 2.7 light hours).

With the speed $\beta c = 3 \cdot 10^7 \text{ m/s}$ the beam traverses this distance in $\approx 27 \text{ h}$ (\approx one day).
With the circumference of $C \approx 80 \text{ m}$ this corresponds to about $4 \cdot 10^{10}$ revolutions.
(Note: earth made about $5 \cdot 10^9$ revolutions around sun since birth of solar system!!!)

For an average **beta function of 10 m**, the rms scattering angle of $5 \cdot 10^{-3} \text{ rad}$ corresponds to an increase of the 1σ -emittance by $\Delta\varepsilon_{1\sigma} = 125 \pi \text{ mm mrad}$.

With an acceptance of $125 \pi \text{ mm mrad}$ 60 % of a Gaussian beam would be lost in 27 h.

Note: At 10^{-12} torr one has $3.3 \cdot 10^4 \text{ molecules/cm}^3$. Typical Lear beam: $10 \cdot 10^4 \text{ pbar/cm}^3$



Intra-beam scattering

Small angle (multiple) Coulomb scattering between beam particles can lead to blow up.
In the collisions, energy transfer: longitudinal \leftrightarrow horizontal \leftrightarrow vertical occurs.

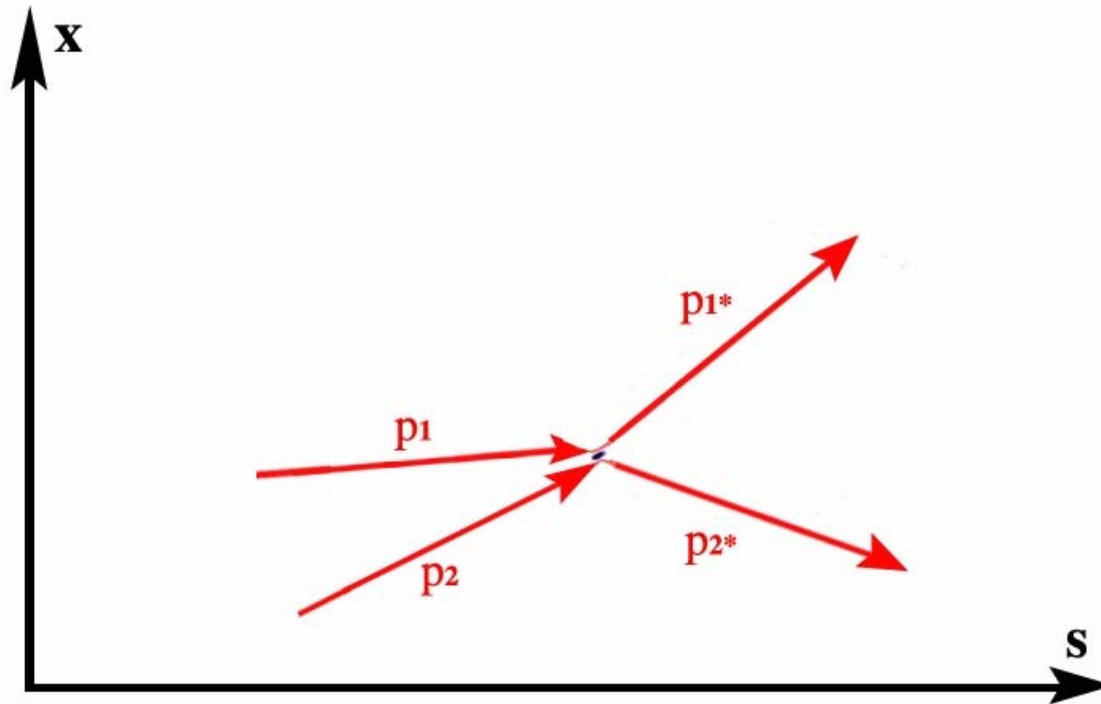

Outline of the calculation

(due to A. Piwinski, 1974 and 1979)

- Transform the momenta of the two colliding particle into their c.m.-system.
- Calculate the change of the momenta using the Rutherford cross-section.
- Transform the changed momenta back into the laboratory system.
- Calculate the change of the emittances due to the change of momenta at the given location of the collision.
- Take the average over all possible scattering angles (impact parameters from the size of the nucleus to the beam radius) and the collision probability (from the beam density)
- Assume a ‘Gaussian beam’ (in all three planes). Take the average over momenta and transverse position of the particles at the given location on the ring circumference.
- Finally calculate the average around the circumference (taking the lattice function of the ring into account) to determine the change per turn.



Particularities of IBS.

- In any strong focussing lattice the sum of the emittances always grows (also below transition because of the ‘friction’ due to the derivatives of the lattice functions).
 - The increase of the 6-dimensional phase space volume can be explained by transfer of energy from the common longitudinal motion into transverse energy spread.
 - There can be strong transfer of emittance and theoretically even reduction in one at the expense of fast growth in another plane (in practise the reduction in one plane has not been observed).
-
- For constant lattice functions (weak focussing) and below transition energy, the sum of the three emittances is constant (the beam behaves like a ‘gas. in a box’). Above transition the sum of the emittances always grows (due to the negative mass effect, i.e. particles ‘being pushed go around slower’).



Particularities of IBS, scaling.

The exact IBS growth rates have to be calculated by computer codes. The basic scaling *at high energy* is given by:

$$1/\tau_0 \propto \frac{N_b \frac{q^4}{A^2}}{\varepsilon_x^* \varepsilon_y^* \varepsilon_s^*}$$

where $\varepsilon_{x,y}^* = \beta\gamma\sigma_{x,y}^2/\beta_{x,y}$, $\varepsilon_s^* = \beta\gamma\sigma_s\sigma_{\Delta p/p}(E_0/c)$ are the normalized emittances

One notes

- Strong dependence on ion charge : q^4/A^2 ($\propto q^2$ for fully stripped)
- Linear dependence on (normalized) phase space density:
 $N_b/(\varepsilon_x^* \varepsilon_y^* \varepsilon_s^*)$
- Weak dependence on energy



Examples

Beam	LHC Protons	LHC Lead 82+	LEIR Lead 54+
Energy/nucleon	7 TeV	2.7 TeV	4.2 MeV
Particles/bunch	$1.15 \cdot 10^{11}$	$7.0 \cdot 10^7$	$1.2 \cdot 10^9$
Transverse 1σ emittance, norm. $\varepsilon \cdot \beta \gamma$ [π mm mr]	3.75	1.5	1
Rms bunch length [m]	± 0.075	± 0.079	± 39 (coasting)
Rms momentum spread [10^{-3}]	± 0.11	± 0.11	± 0.5
IBS growth time (shortest)	61 h	7.7 h	2 sec.



Resonance crossing

Dangerous, low order resonances are usually avoided by choosing an appropriate working point (Q_x, Q_y). However high order resonances may be touched and traversed due to small, unavoidable or programmed tune changes. For a rapid traversal of a resonance nQ=integer the emittance increase (after filamentation and for small Δε/ε) is :

$$\Delta \varepsilon_{\sigma} / \varepsilon_{\sigma} \approx \frac{\pi \Delta e}{n \sqrt{\Delta Q_t}} \approx \left(\frac{0.1}{n} \right)_{\text{typically}}$$

(n: order, Δe (~10⁻⁴) : width of the resonance, ΔQ_t (~10⁻⁵): tune change per turn).

Hence only few transitions can be tolerated. For repeated random crossings the amplitude growth is multiplied by the square root of the number crossings.

For slow tune variation, particles can be trapped in resonance ‘bands’ which move them outwards, eventually even to the aperture limit.

-----> **A very high ‘stability’ of the tune is essential**



Power supply noise

Noise in the bending fields lead to a ripple of the origin of the phase space portraits. Noise in the focussing fields leads to wiggling trajectories. Both effects produce emittance diffusion.

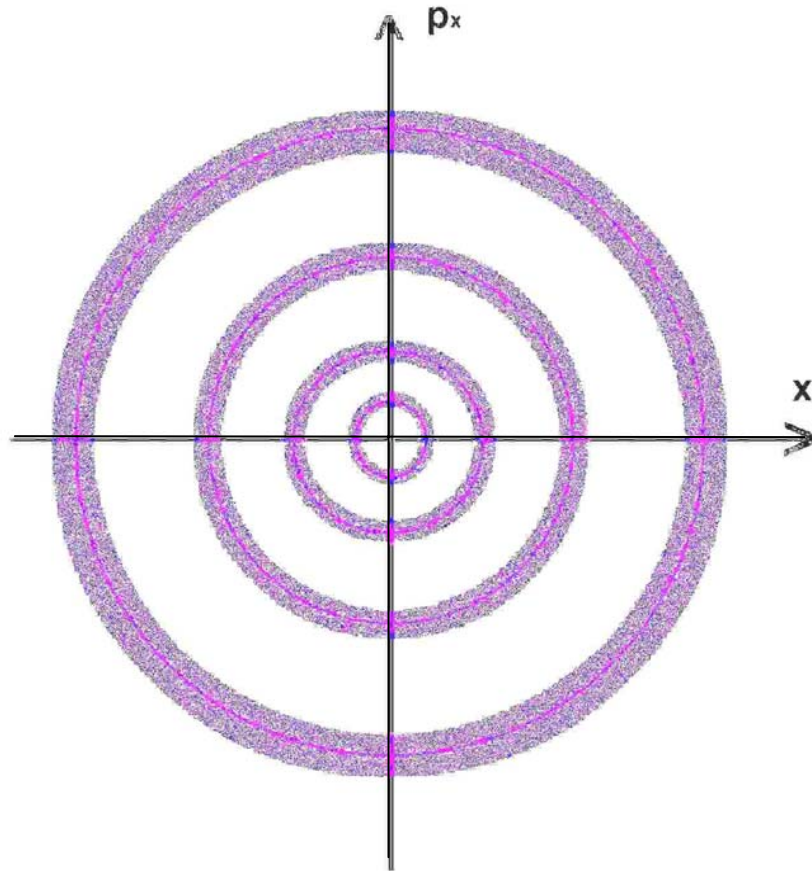
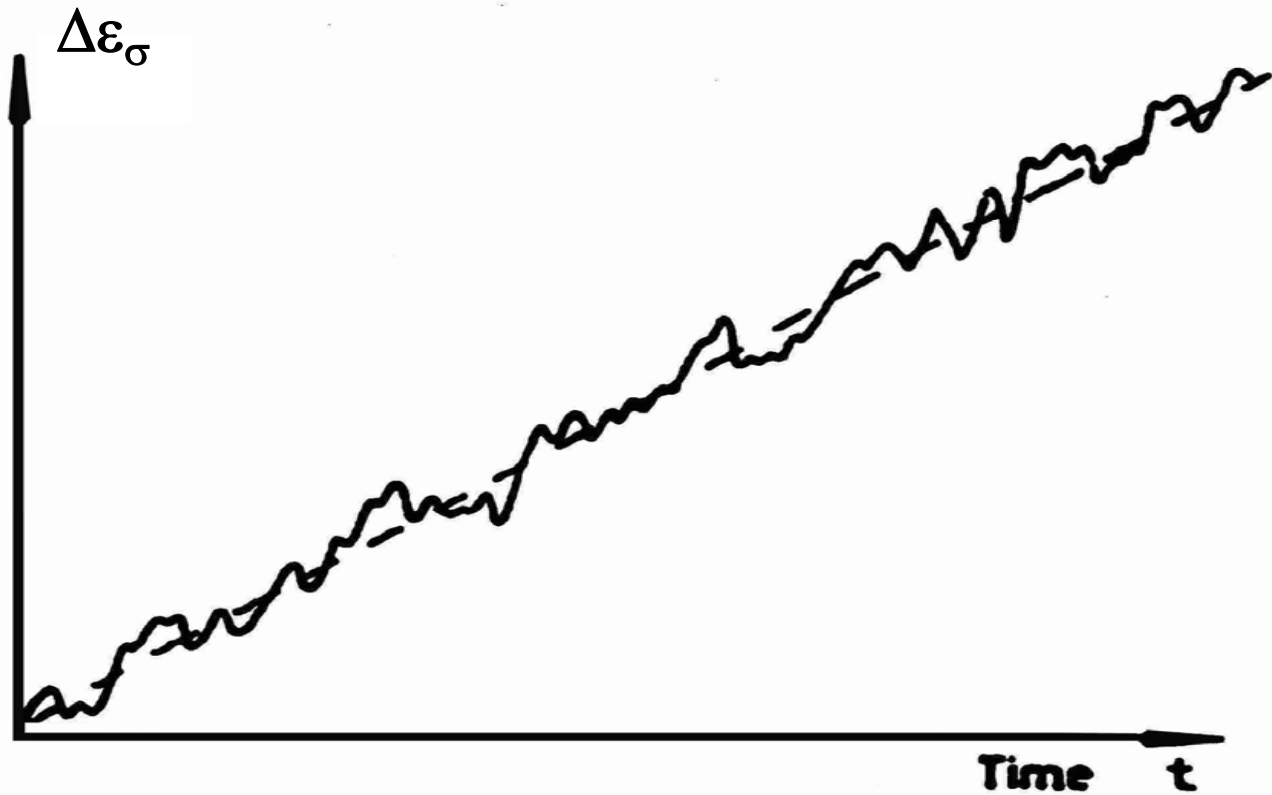

Figure:
Fussy trajectories due
to noise in focussing or
bending fields

Noise, frequency components

Noise components with frequencies near the betatron sidebands $(m \pm Q)f_{\text{rev}}$ lead to a linear emittance increase $\Delta\varepsilon(t)$;
here $m=0, 1, 2, \dots$; often the $(m-Q)$ component with $m \sim Q$ has the dominant effect.



Hereward and Johnson's (yellow) report on noise (CERN/60-38)

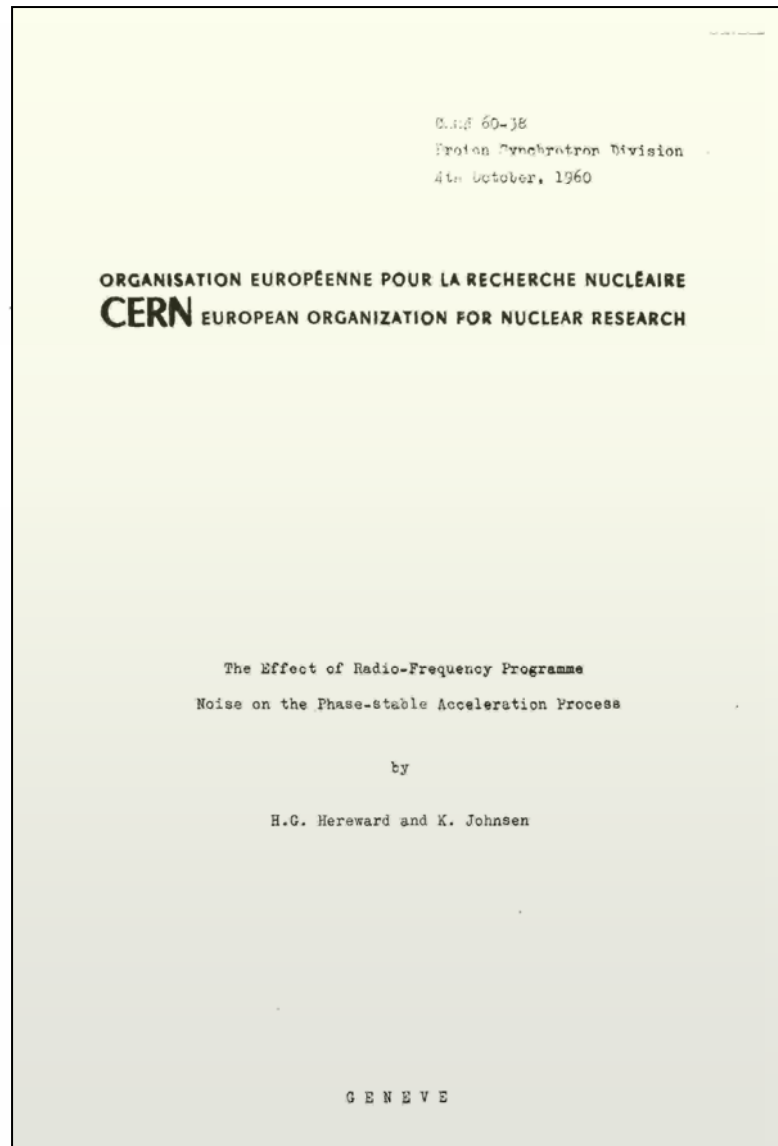

Conclusion

- **Emittance (i.e. beam density) preservation is a major concern in the design of modern accelerators and colliders.**
- **There is a great number of ‘single particle’ and ‘collective’ effects which have to be perfectly controlled to avoid excessive ‘beam heating’.**
- **Beam cooling (to be treated in Danared’s lecture) can be used to fight growth and even lead to very small equilibrium emittances. These result from the balance between the cooling and (many of) the heating mechanisms mentioned.**



Phase space position of a particle at different turns

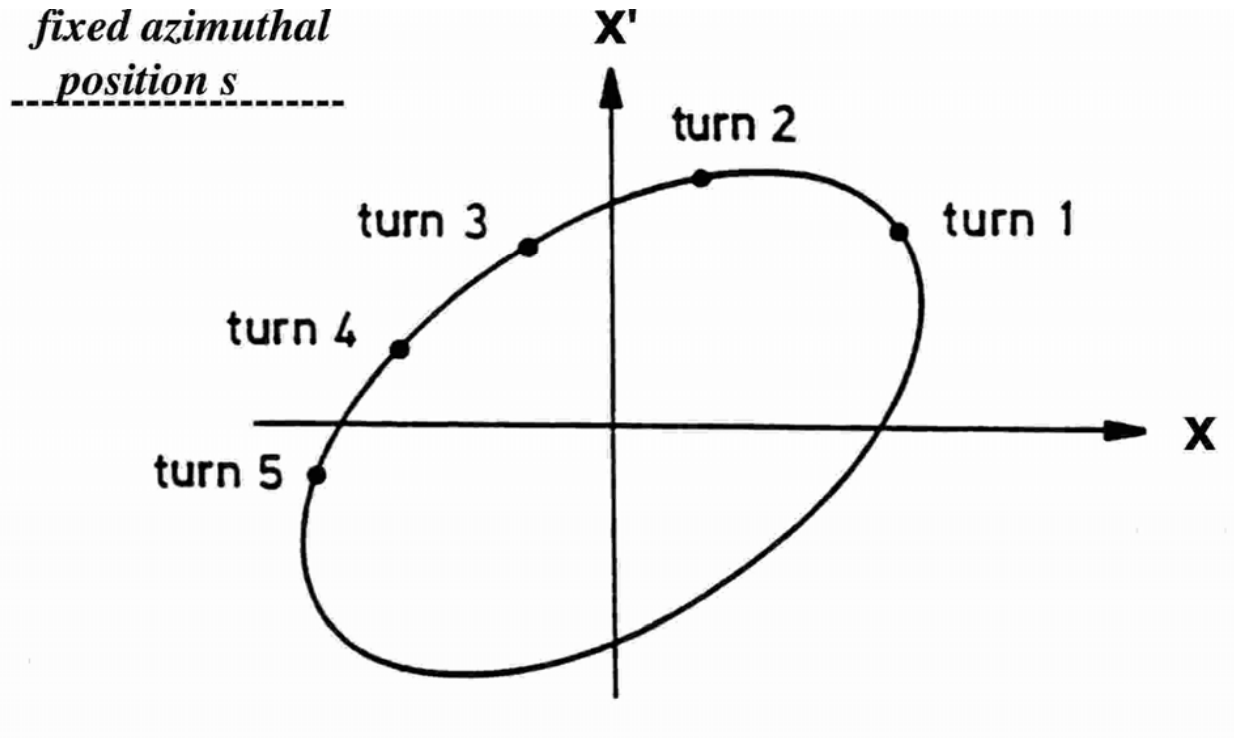

Observed turn by turn at a fixed azimuthal position (s), the coordinates of a particle trace the ellipse. During each revolution the phase ψ advances by $2\pi Q$

Trajectory of particles with different phases and amplitudes

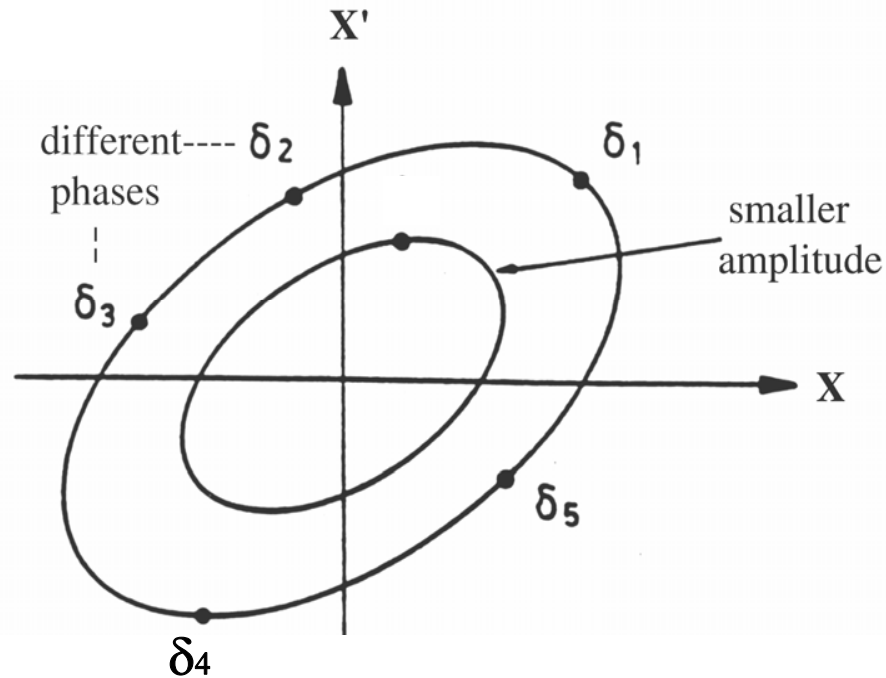

Viewed at fixed azimuth and time the phase space coordinates of particles with different initial phases trace the ellipse. Particles with different amplitude lie on different concentric ellipses.

Momentum error, dispersion error

Assume a beam is injected with a **momentum error** $\delta p/p$.
If the dispersion D of the transfer **line matches the dispersion of the ring** *and* the beam is centred around its displaced ($\delta x = D\delta p/p$, $\delta x' = D'\delta p/p$) off-momentum **orbit, then perfect matching** will prevail. If however the beam is injected onto the centre of the aperture, it has a position error

$$\Delta r = \{ D^2 + (\beta D' + \alpha D)^2 \}^{1/2} \delta p/p,$$

and our previous formulae can be used

