

Introduction to Power Converters

Neil Marks,

STFC/Cockcroft Institute/U. of Liverpool,

Daresbury Laboratory,

Warrington WA4 4AD,

U.K.

n.marks@dl.ac.uk

Contents

1. Basic elements of power supplies.

2. D.C. supplies:

- i) simple rectification with diodes;**
- ii) phase controlled rectifiers;**
- iii) ‘other’ conventional d.c. systems;**
- iv) switch mode systems.**

2. Cycling converters:

- i) accelerator requirements** **– energy storage;**
– waveform criteria;
- ii) slow cycling systems;**
- iii) fast cycling systems;**
- iv) switch-mode systems with capacitor storage.**

1 - Basic components.

Generic structure of a 'Power Converter':

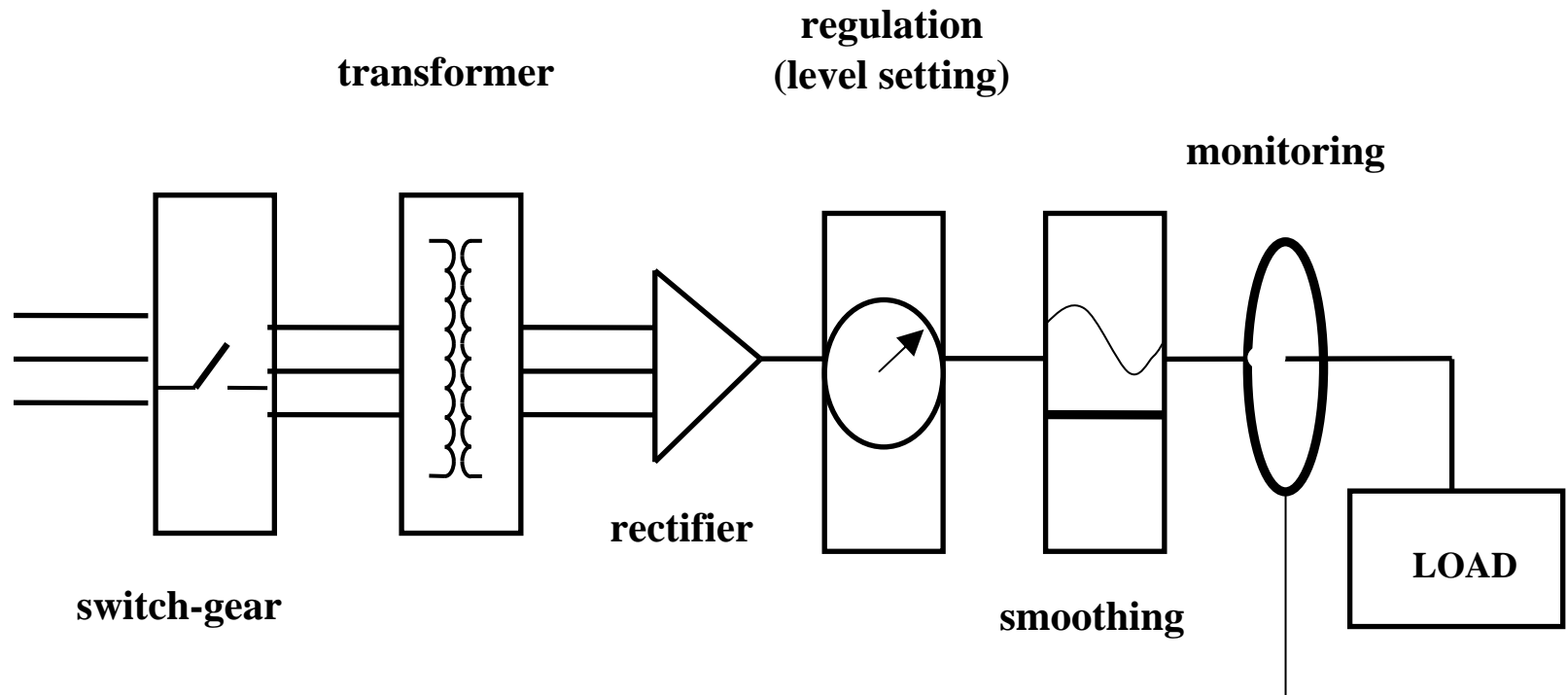

Basic components (cont.)

i) switch-gear:

- on/off;
- protection against over-current/over-voltage/earth leakage etc.

ii) transformer:

- changes voltage – ie matches impedance level;
- provides essential galvanic isolation load to supply;
- three phase or (sometimes 6 or 12 phase);

iii) rectifier/ switch (power electronics):

- used in both d.c. and a.c. supplies;
- number of different types – see slides 6, 7, 8;

Basic components (cont.)

iv) regulation:

- level setting;
- stabilisation with high gain servo system;
- strongly linked with ‘rectifier’ [item iii) above];

v) smoothing:

- using either a passive or active filter;

vi) monitoring:

- for feed-back signal for servo-system;
- for monitoring in control room;
- for fault detection.

Switches - diode

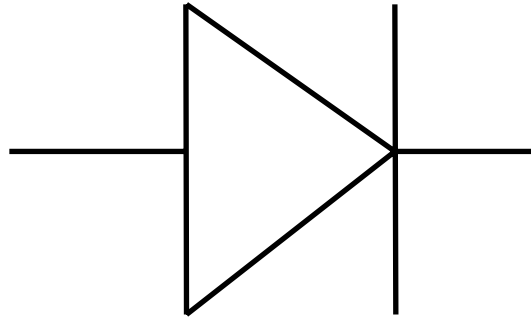

- conducts in forward direction only;
- modern power devices can conduct in $\sim 1 \mu\text{s}$;
- has voltage drop of ($< 1 \text{ V}$) when conducting;
- hence, dissipates power whilst conducting;
- ratings up to many 100s A (average), kVs peak reverse volts.

Switches - thyristor

- Withstands forward and reverse volts until the 'gate' receives a pulse of current;
- then conducts in the forward direction;
- conducts until current drops to zero and reverses (for a short time to 'clear' carriers);
- after 'recovery time', again withstands forward voltage;
- switches on in $\sim 5 \mu\text{s}$ (depends on size) – as the forward voltage drops, it dissipates power as current rises;
- therefore dI/dt limited during early conduction;
- available with many 100s A average, kVs forward and reverse volts.

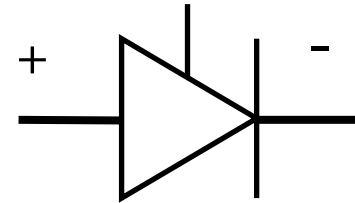

Switches – i.g.b.t. s

The insulated gate bi-polar transistor (i.g.b.t.):

- gate controls conduction, switching the device **on** and **off**;
- far faster than thyristor, can operate at 10s of kHz;
- is a transistor, so will **not** take reverse voltage (usually a built-in reverse diode);
- dissipates significant power during switching;
- is available at ~ 2 kV forward, 100s A average.

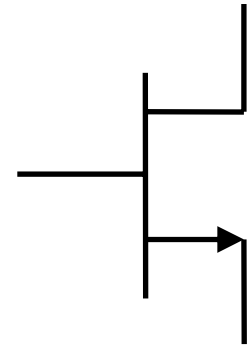

2. DC Supplies

A single phase full-wave rectifier:

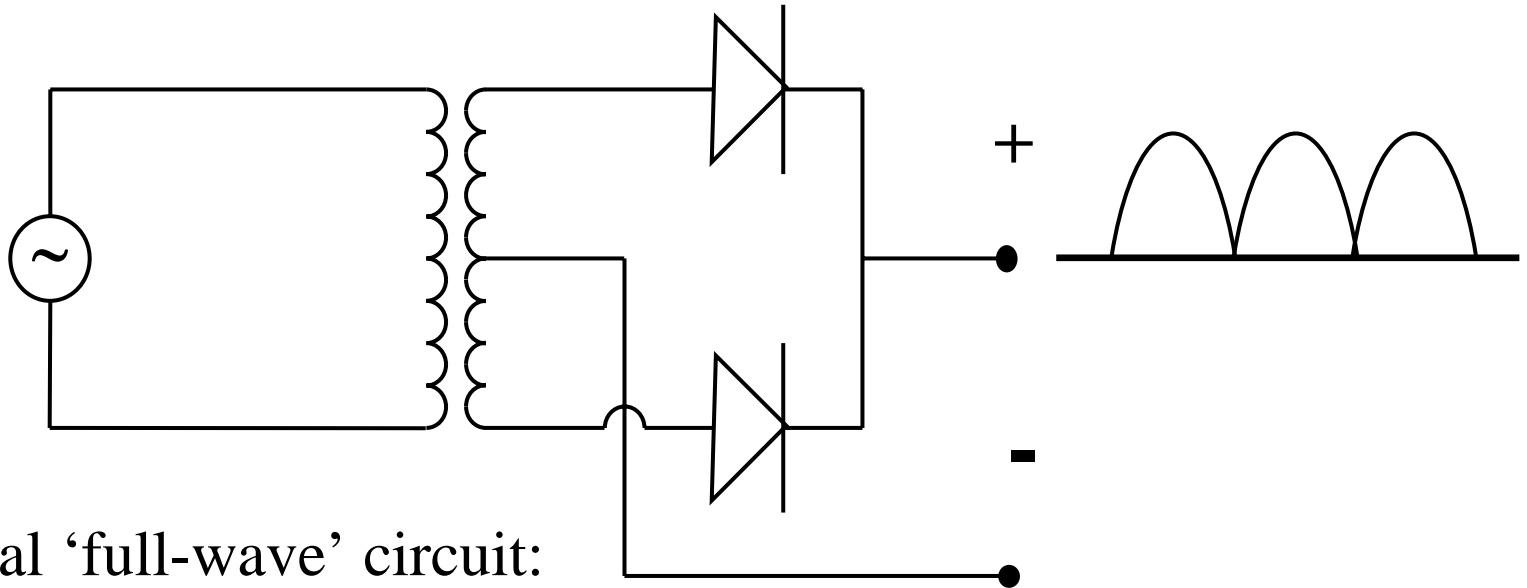

Classical 'full-wave' circuit:

- uncontrolled – no amplitude variation or control;
- large ripple – large capacitor smoothing necessary;
- only suitable for small loads.

DC – a 3 phase diode rectifier

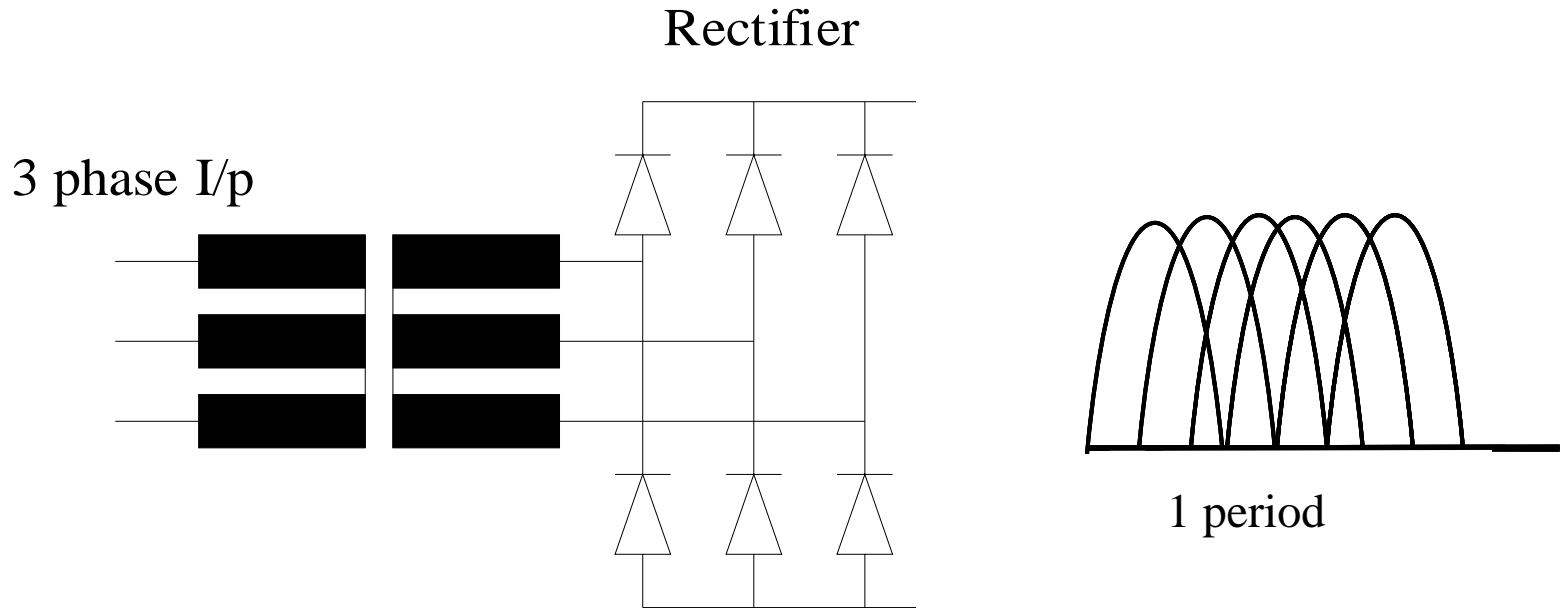

Three phase, six pulse system:

- no amplitude control;
- much lower ripple ($\sim 12\%$ 6th harmonic – 300 Hz) but low-pass filters still needed.

Thyristor phase control

Replace diodes with thyristors - amplitude of the d.c. is controlled by retarding the conduction phase:

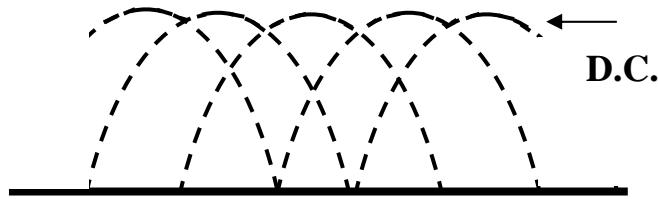

Full conduction – like diode

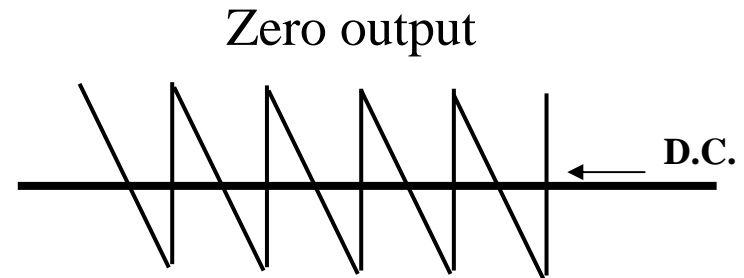

Zero output

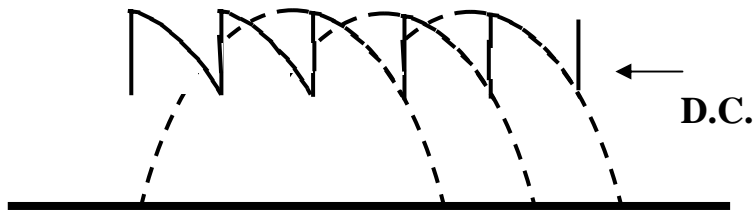

Half conduction

negative output – ‘inversion’ (but current must still be positive).

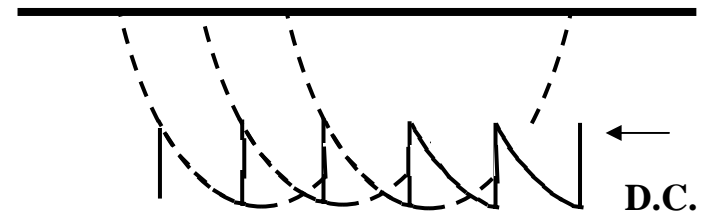

Full 12 pulse phase controlled circuit.

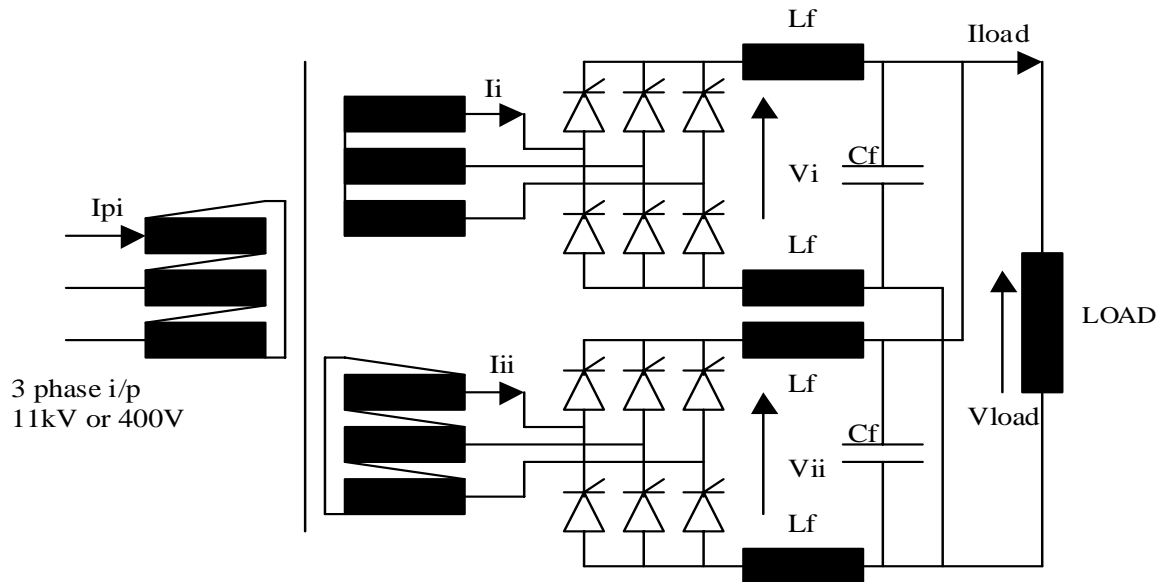

- like all thyristor rectifiers, is ‘line commutated’;
- produces 600 Hz ripple (~ 6%)
- but smoothing filters still needed.

The thyristor rectifier.

The ‘standard’ circuit until recently:

- gave good precision (better than $1:10^3$);
- inversion protects circuit and load during faults;
- has bad power factor with large phase angles (V and I out of phase in ac supply) ;
- injected harmonic contamination into load **and** 50 Hz a.c. distribution system at large phase angles.

Example of other (obsolete) systems.

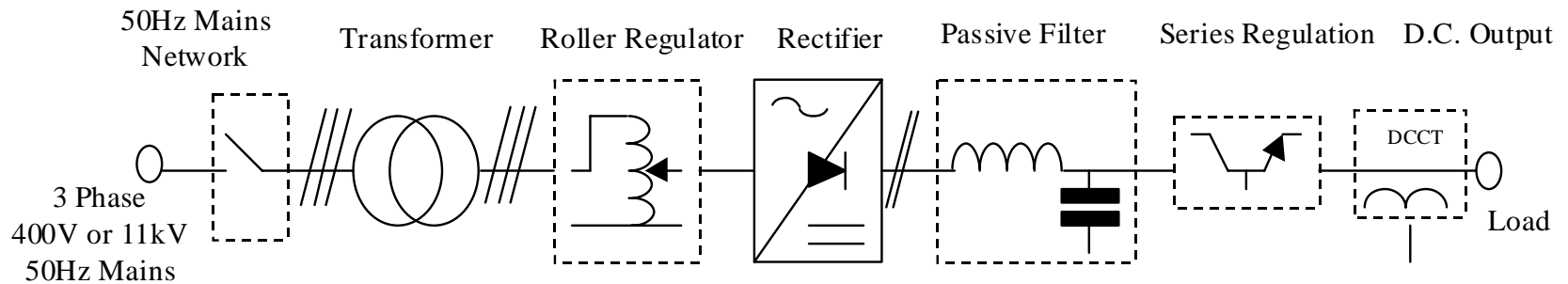

This circuit uses:

- a variable transformer for changing level (very slow);
- diode rectification;
- a series regulator for precision (class A transistors !);
- good power factor and low harmonic injection into supply and load.

Modern 'switch-mode' system.

The i.g.b.t. allows a new, revolutionary system to be used: the '**switch-mode**' power supply:

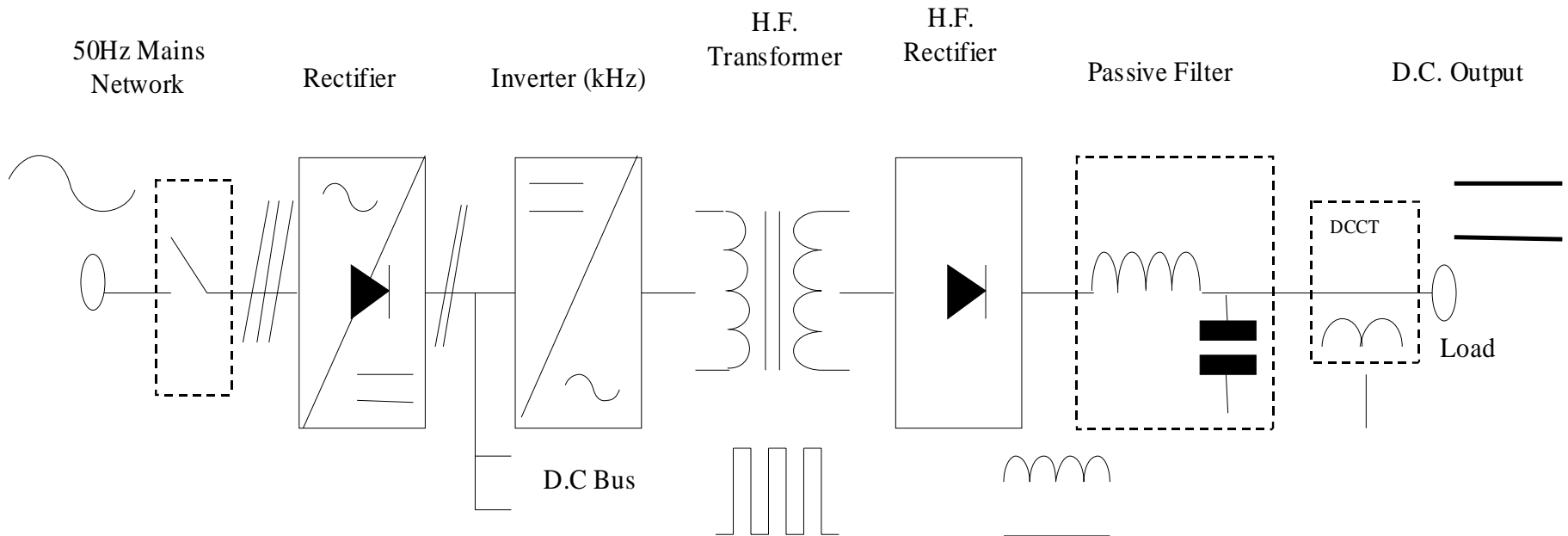

Mode of operation

Stages of power conversion:

- incoming a.c. is rectified with diodes to give ‘raw’ d.c.;
- the d.c. is ‘chopped’ at high frequency (> 10 kHz) by an inverter using i.g.b.t.s;
- a.c. is transformed to required level (transformer is much smaller, cheaper at high frequency);
- transformed a.c. is rectified – diodes;
- filtered (filter is much smaller at 10 kHz);
- regulation is by feed-back to the inverter (much faster, therefore greater stability and faster protection);
- response and protection is very fast.

Inverter

The inverter is the heart of the switch-mode supply:

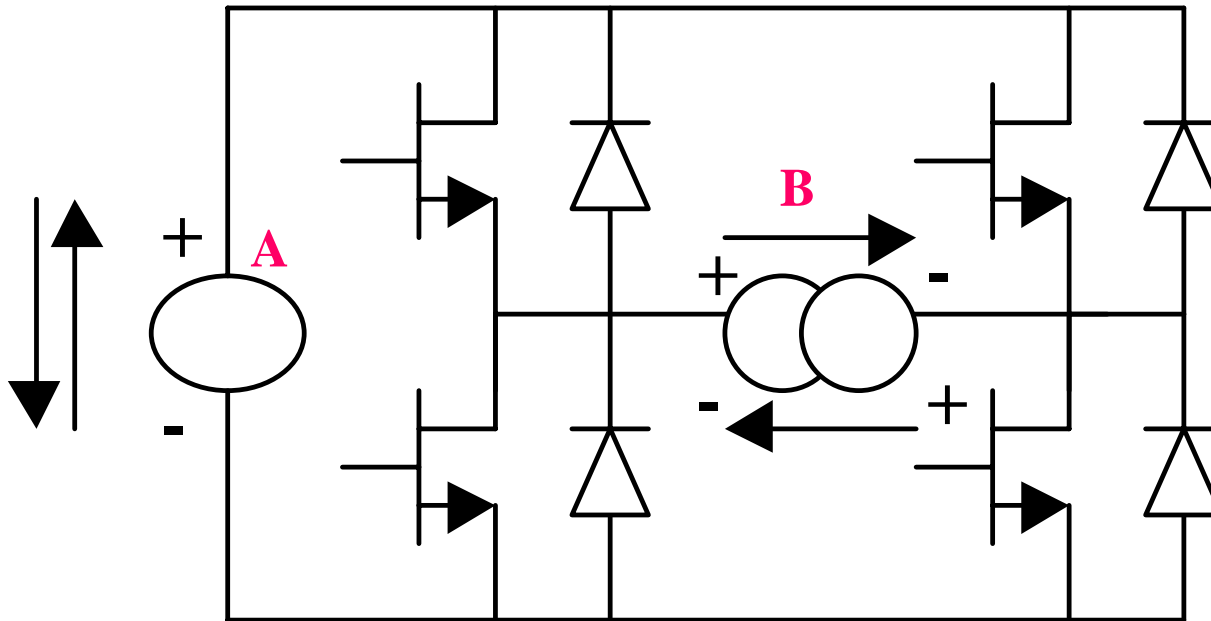

The i.g.b.t. s provide full switching flexibility – switching on or off according to external control protocols.

Point A: direct voltage source; current can be bidirectional (eg, inductive load, capacitive source).

Point B: voltage square wave, bidirectional current.

3. Cycling converters.

What do we need? – will ‘ordinary’ A.C. do?

The required magnetic field (magnet current) is unidirectional – acceleration low to high energy: - so ‘normal’ a.c. is inappropriate:

- only $\frac{1}{4}$ cycle used;
- excess rms current;
- high a.c. losses;
- high gradient at injection.

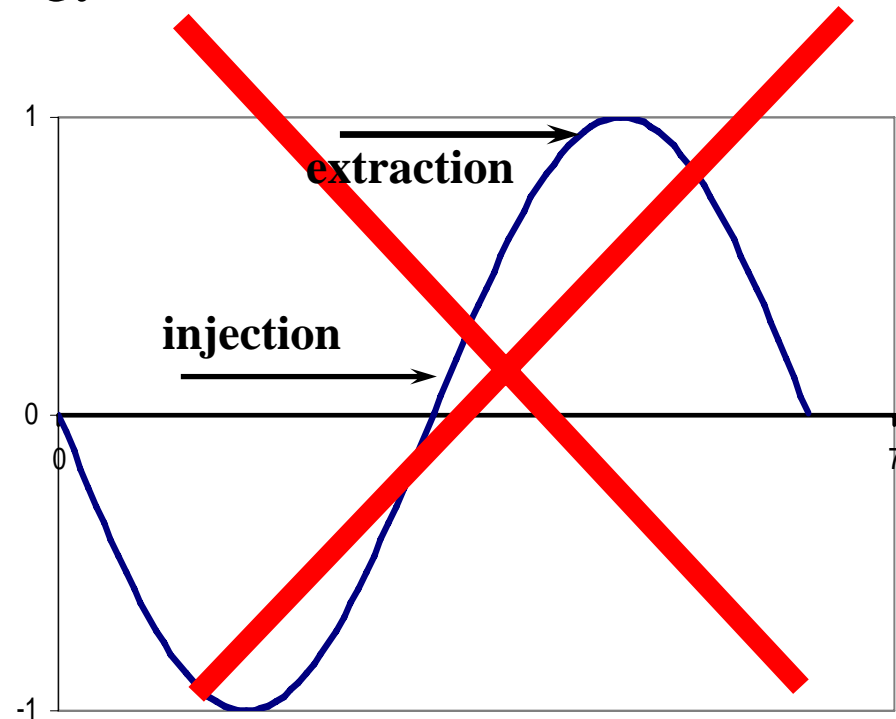

Nature of the Magnet Load

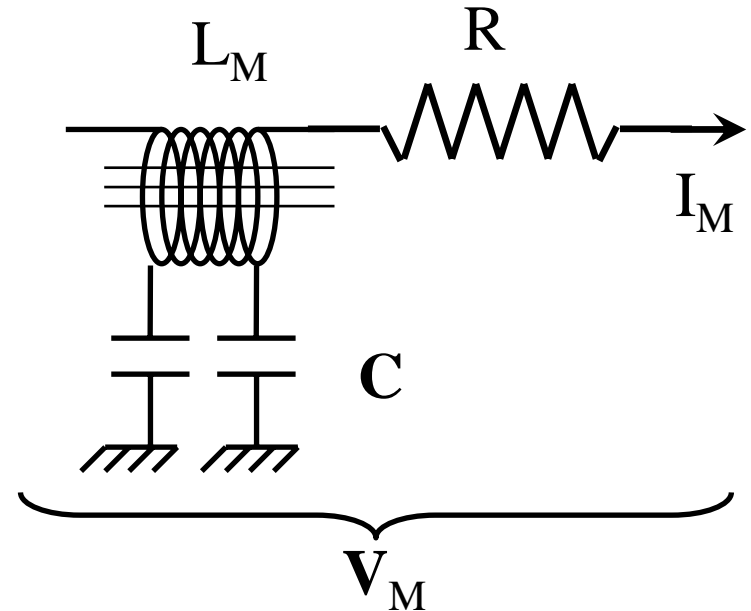
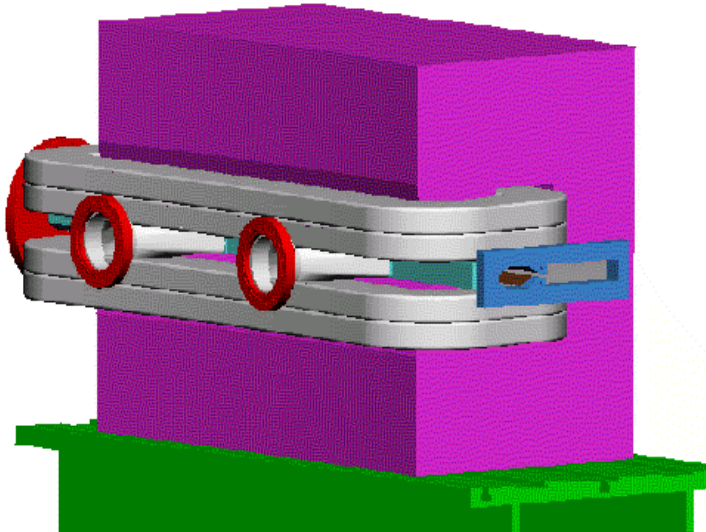

Magnet current:

I_M ;

Magnet voltage:

V_M

Series inductance:

L_M ;

Series resistance:

R ;

Distributed capacitance to earth

C .

'Reactive' Power and Energy

voltage: $V_M = R I_M + L (d I_M/dt);$

'power': $V_M I_M = R (I_M)^2 + L I_M(d I_M/dt);$

stored energy: $E_M = 1/2 L_M (I_M)^2;$

$$d E_M /dt = L (I_M) (d I_M/dt);$$

so $V_M I_M = R (I_M)^2 + d E_M /dt;$

resistive power loss; reactive' power – alternates between +ve and -ve as field rises and falls;

The challenge of the cyclic power converter is to provide and control the positive and negative flow of energy - energy storage is required.

Waveform criteria – eddy currents.

Generated by alternating magnetic field cutting a conducting surface:

eddy current in vac. vessel & magnet; $\propto \partial B/\partial t$;

eddy currents produce:

- negative dipole field - reduces main field magnitude;
- sextupole field – affects chromaticity/resonances;

eddy effects proportional $(1/B)(dB/dt)$ – critical at injection.

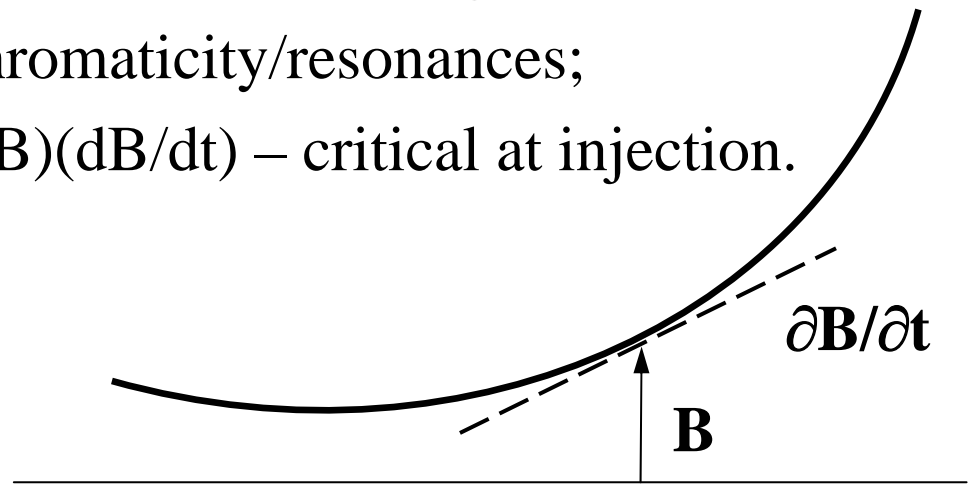

Waveform criteria – discontinuous operation

Circulating beam in a storage ring slowly decay with time – very inconvenient for experimental users.

Solution – ‘**top up mode**’ operation by the booster synchrotron – beam is only accelerated and injected once every n booster cycles, to maintain constant current in the main ring.

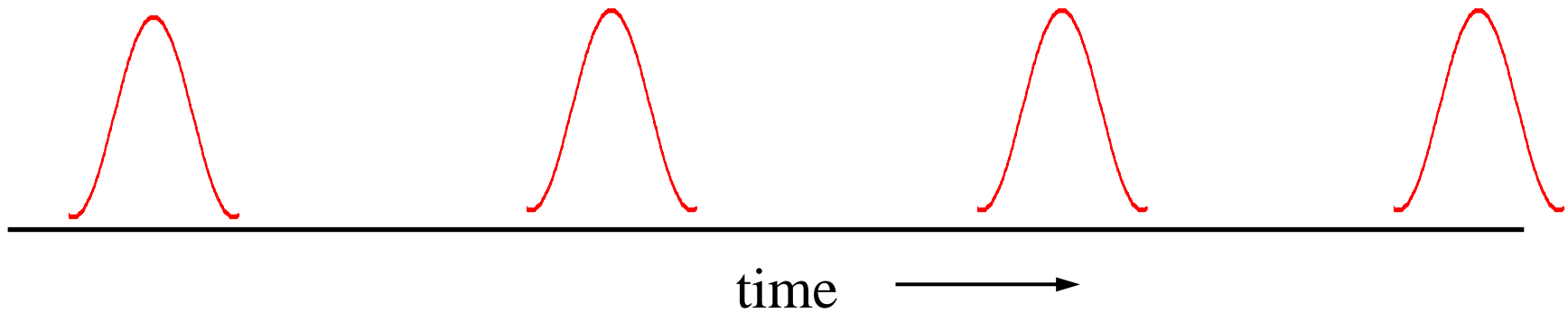

Fast and slow cycling accelerators.

‘Slow cycling’:

- repetition rate 0.1 to 1 Hz (typically 0.3 Hz);
- large proton accelerators;

‘Fast cycling’:

- repetition rate 10 to 50 Hz;
- combined function electron accelerators (1950s and 60s) and high current medium energy proton accelerators;

‘Medium cycling’:

- repetition rate 0.1 to 5 Hz;
- separated function electron accelerators;

Example 1 – the CERN SPS

A slow cycling synchrotron.

Dipole power supply parameters (744 magnets):

- peak proton energy 450 GeV;
- cycle time (fixed target) 8.94 secs;
- peak current 5.75 kA;
- peak dI/dt 1.9 kA/s;
- magnet resistance 3.25 Ω ;
- magnet inductance 6.6 H;
- magnet stored energy 109 MJ;

SPS Current waveform

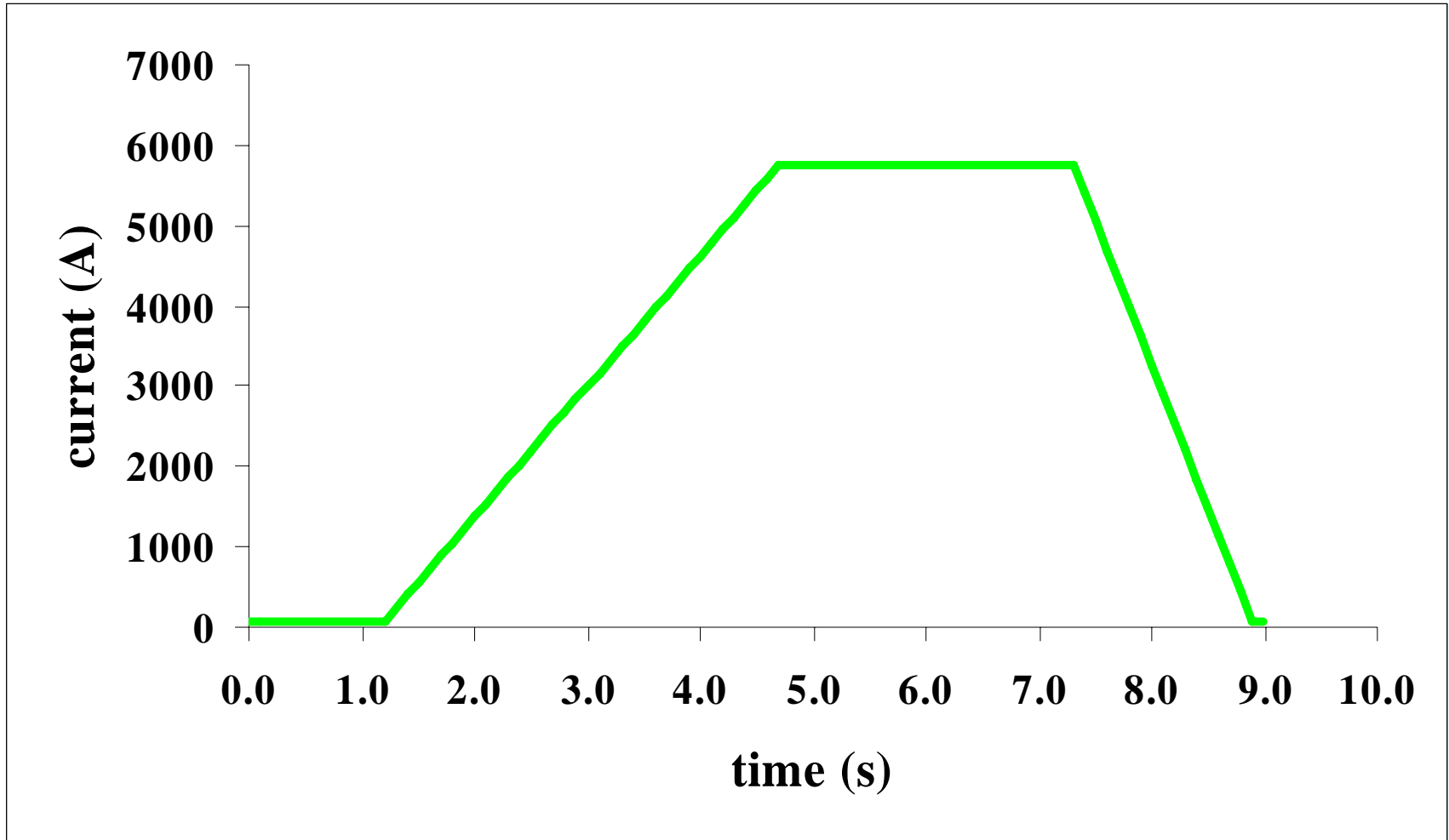

SPS Voltage waveforms

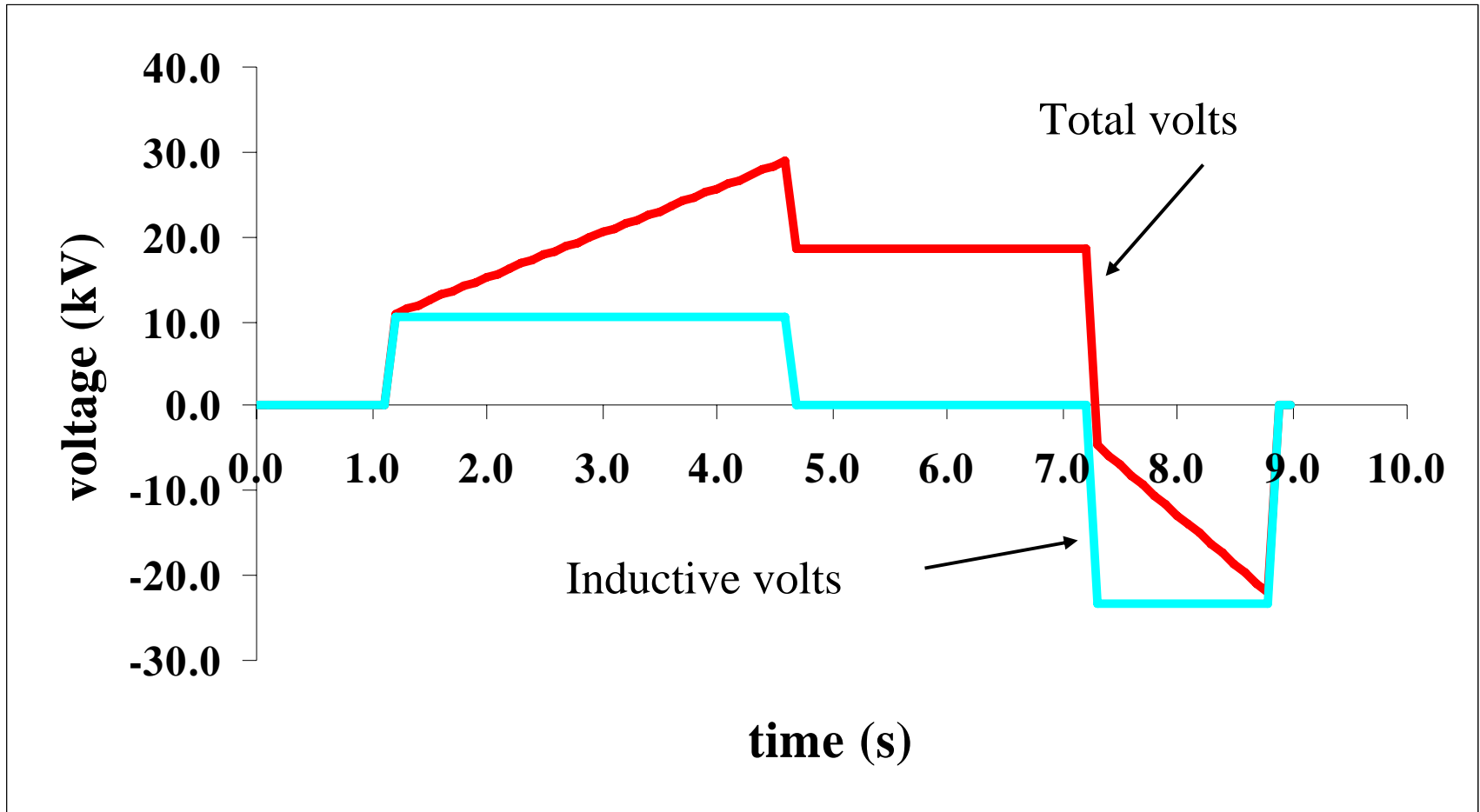

SPS Magnet Power

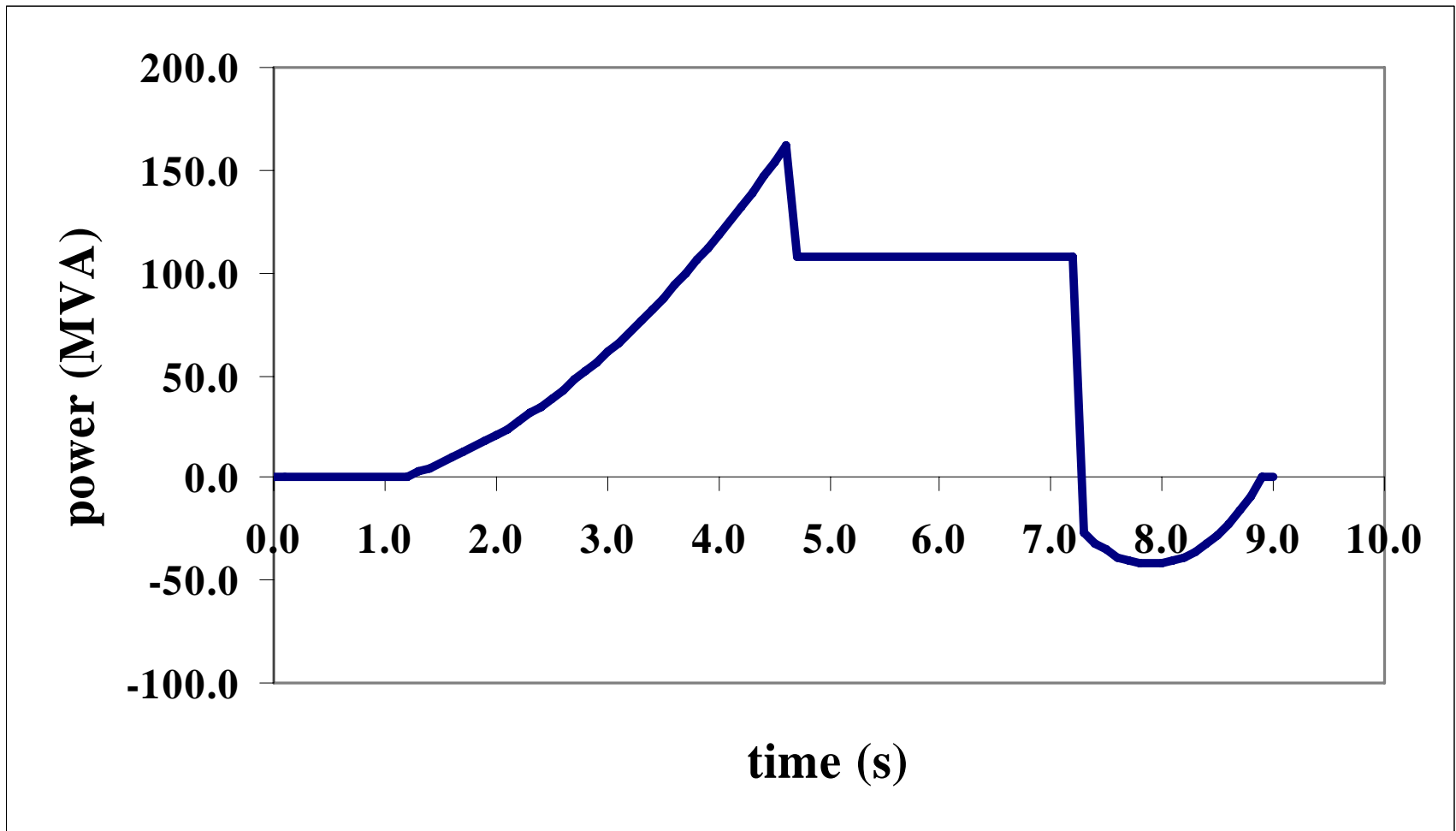

Example 2 – NINA (D.L.)

A fast cycling synchrotron

magnet power supply parameters;

- peak electron energy 5.0 GeV;
- cycle time 20 msec;
- cycle frequency 50 Hz
- peak current 1362 A;
- magnet resistance 900 m Ω ;
- magnet inductance 654 mH;
- magnet stored energy 606 kJ;

NINA Current waveform

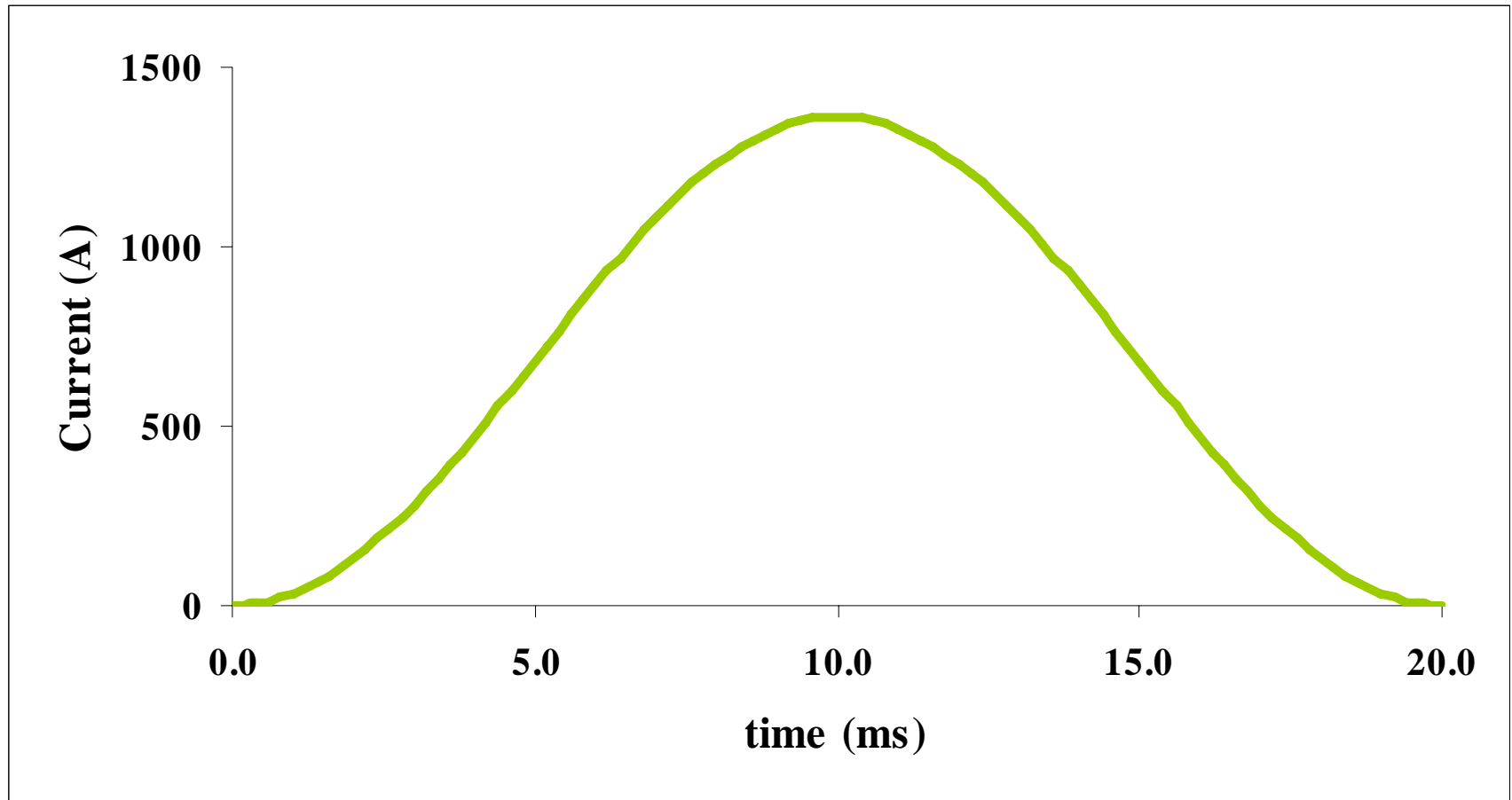

NINA Voltage waveform

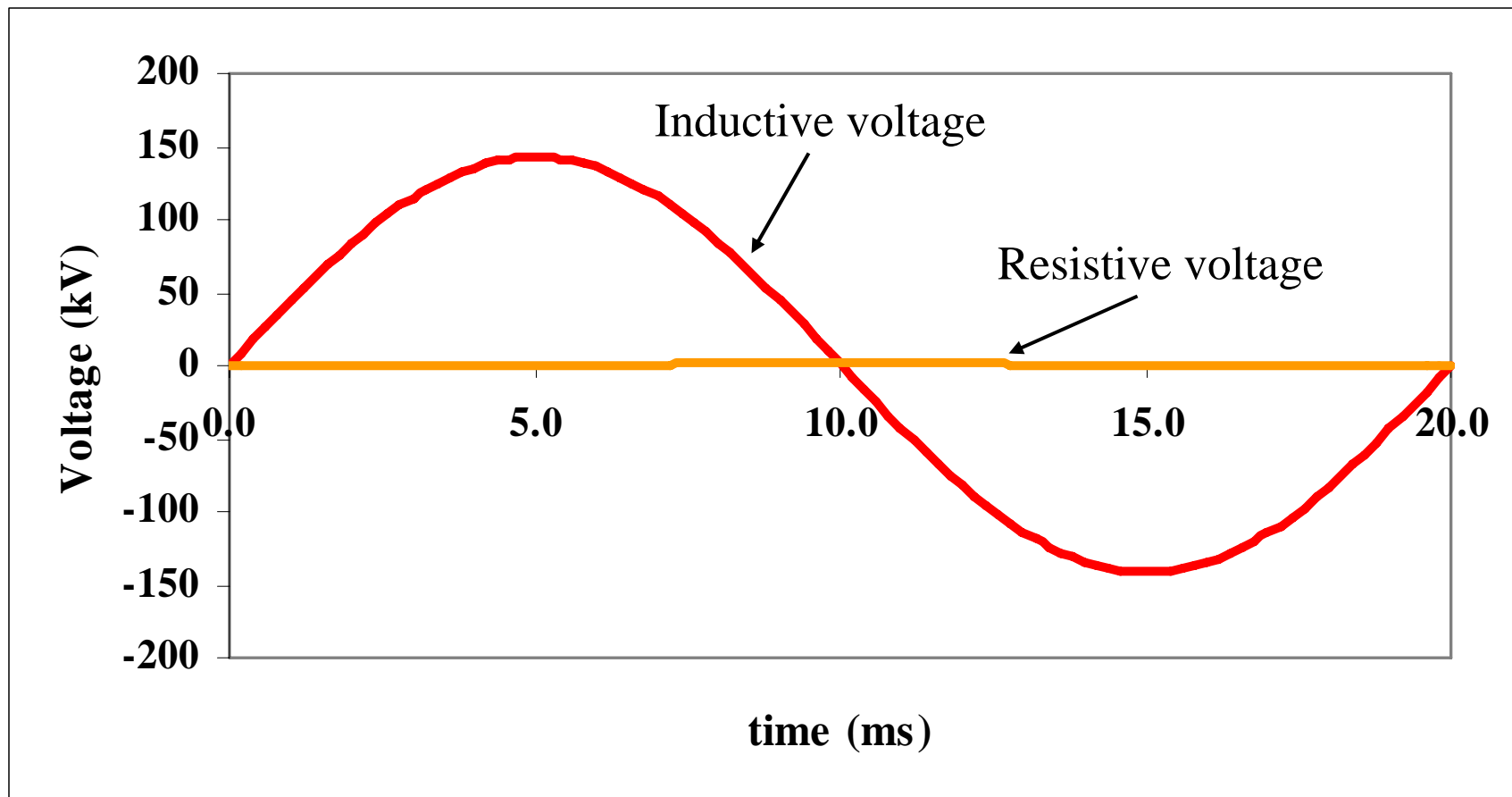

NINA Power waveform

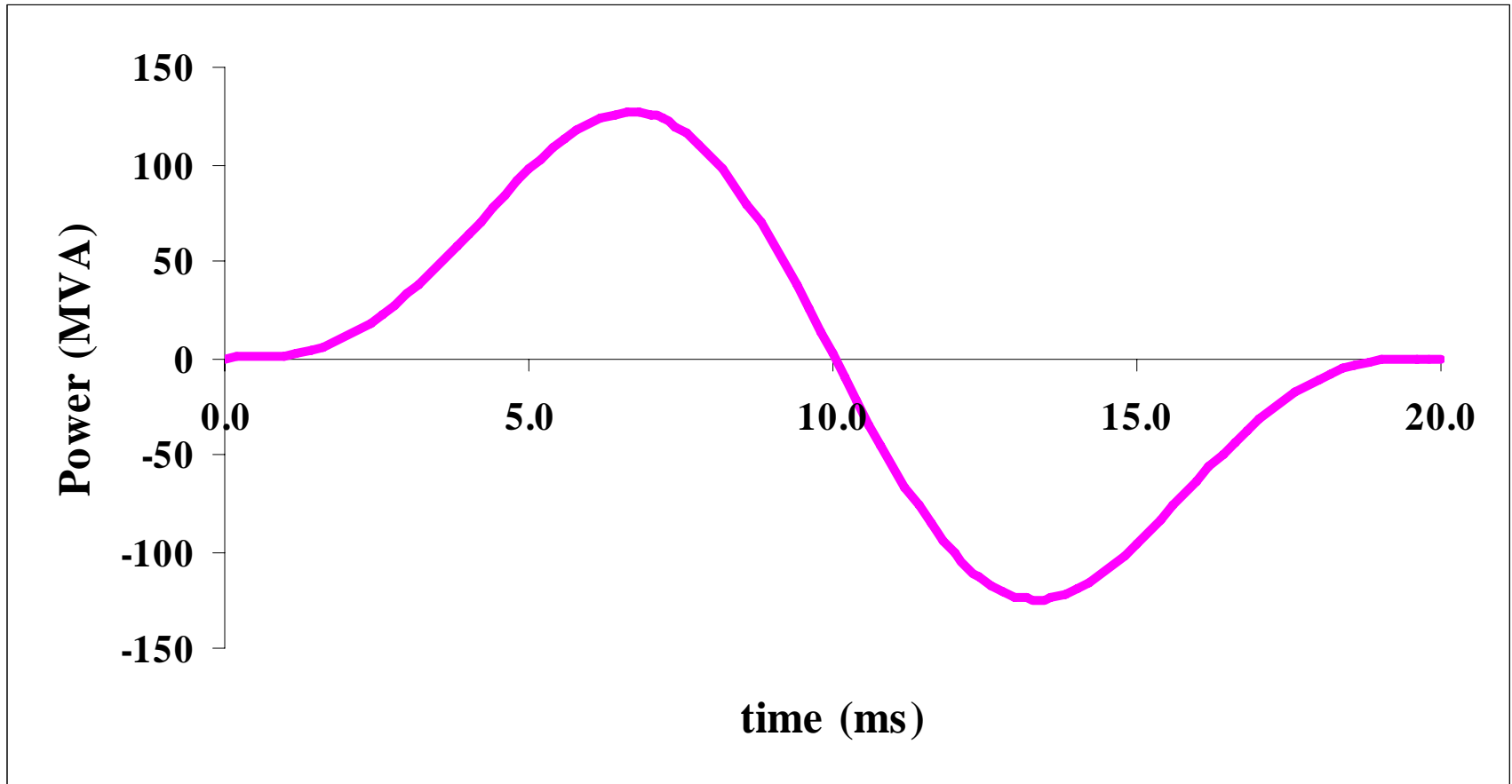

Cycling converter requirements

Summing up - a power converter system needs to provide:

- a unidirectional alternating waveform;
- accurate control of waveform amplitude;
- accurate control of waveform timing;
- storage of magnetic energy during low field;
- if possible, **waveform control**;
- if needed (and possible) discontinuous operation for ‘top up mode’.

'Slow Cycling' Mechanical Storage

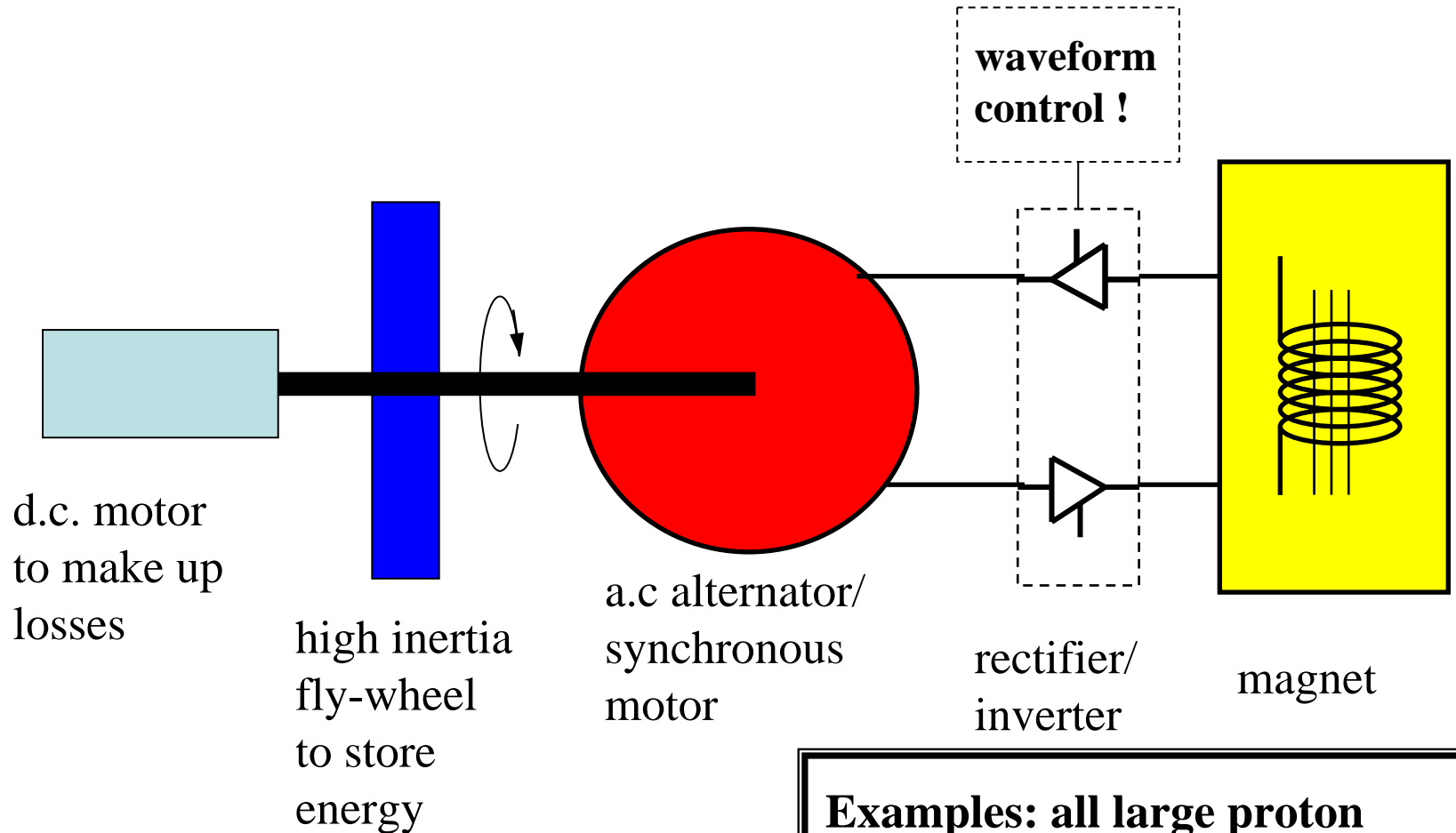

Examples: all large proton accelerators built in 1950/60s.

'Nimrod'

The alternator,
fly-wheel
and d.c. motor

of the 7 GeV
weak-focusing
synchrotron,
NIMROD

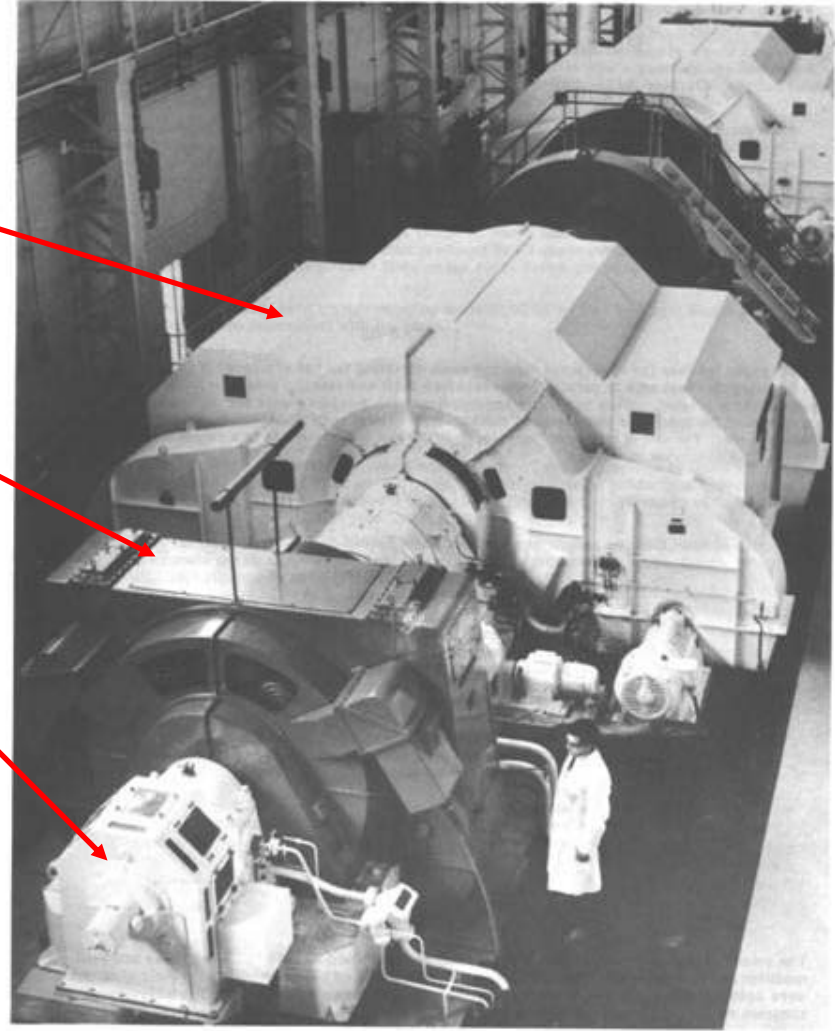

‘Slow cycling’ direct connection to supply network

National supply networks have large stored (inductive) energy; with the correct interface, this can be utilised to provide and receive back the reactive power of a large accelerator.

Compliance with supply authority regulations must minimise:

- voltage ripple at feeder;
- phase disturbances;
- frequency fluctuations over the network.

A ‘rigid’ high voltage line in is necessary.

Example - Dipole supply for the SPS

14 converter modules (each 2 sets of 12 pulse phase controlled thyristor rectifiers) supply the ring dipoles in series; waveform control!

Each module is connected to its own 18 kV feeder, which are directly fed from the 400 kV French network.

Saturable reactor/capacitor parallel circuits limit voltage fluctuations.

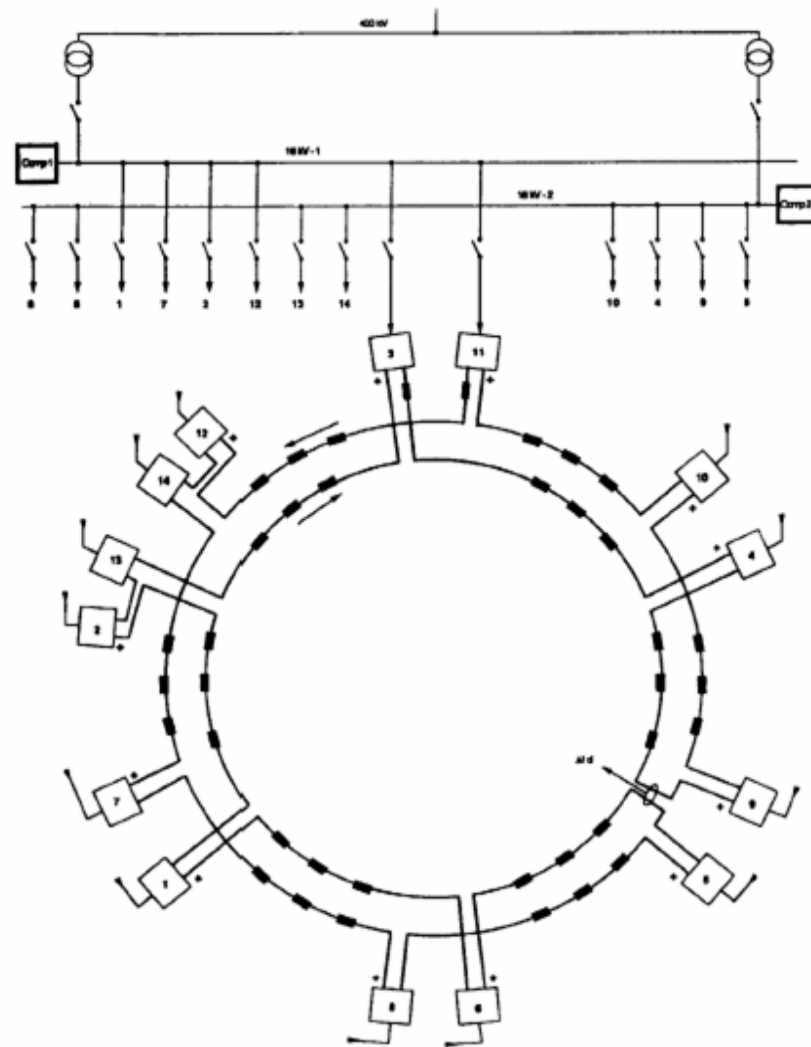

Medium & fast cycling inductive storage.

Fast and medium cycling accelerators (mainly electron synchrotrons) developed in 1960/70s used inductive energy storage:

inductive storage was roughly half the cost per kJ of capacitative storage.

The ‘standard circuit’ was developed at Princeton-Pen accelerator – the ‘White Circuit’.

White Circuit – single cell.

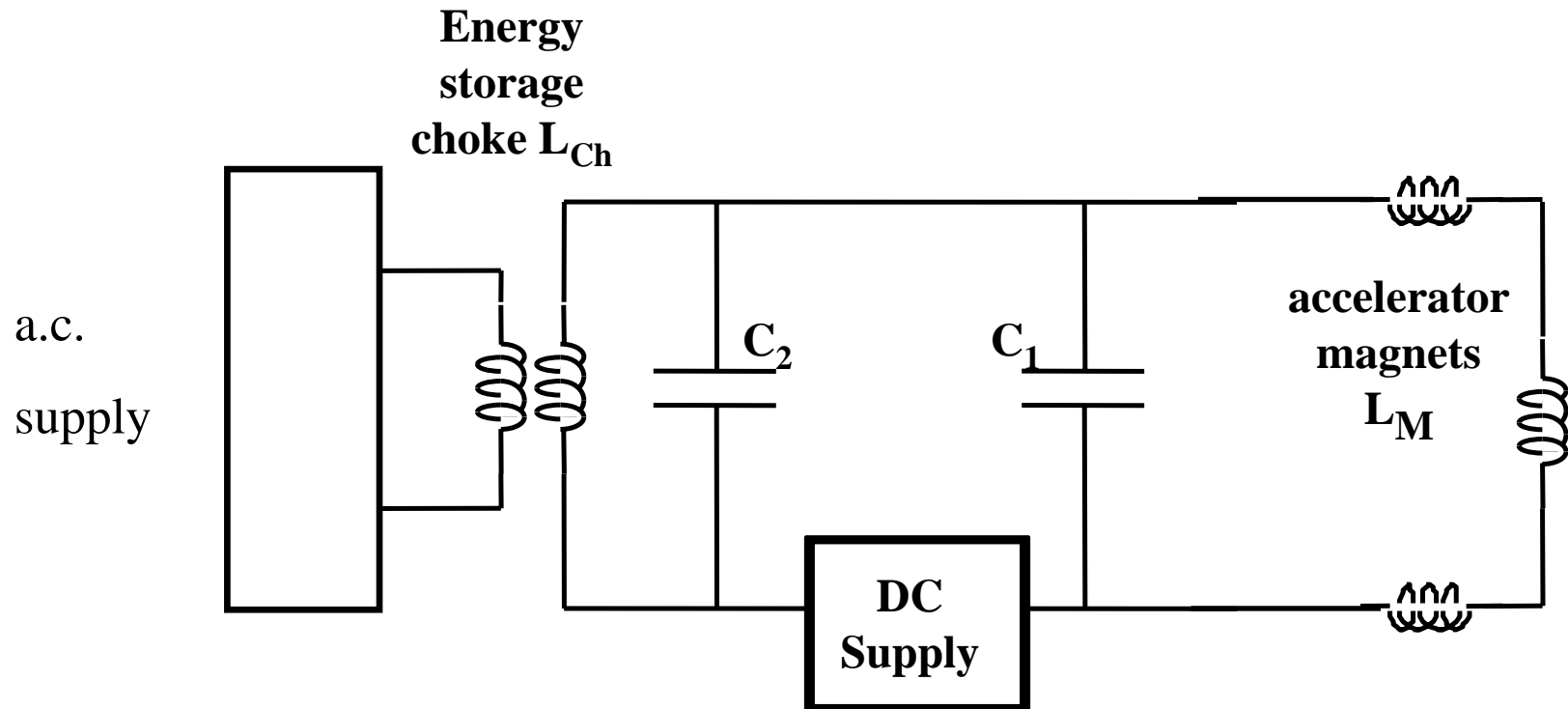

Examples: Boosters for ESRF, SRS; (medium to fast cycling 'small' synchrotrons).

White circuit (cont.)

Single cell circuit:

- magnets are all in series (L_M);
- circuit oscillation frequency ω ;
- C_1 resonates magnet in parallel: $C_1 = \omega^2/L_M$;
- C_2 resonates energy storage choke: $C_2 = \omega^2/L_{Ch}$;
- energy storage choke has a primary winding closely coupled to the main winding;
- only small ac present in d.c. source;
- no d.c. present in a.c source;
- **NO WAVEFORM CONTROL.**

White Circuit magnet waveform

Magnet current is biased sin wave – amplitude of I_{AC} and I_{DC} independently controlled.

Usually fully
biased,
so $I_{DC} \sim I_{AC}$

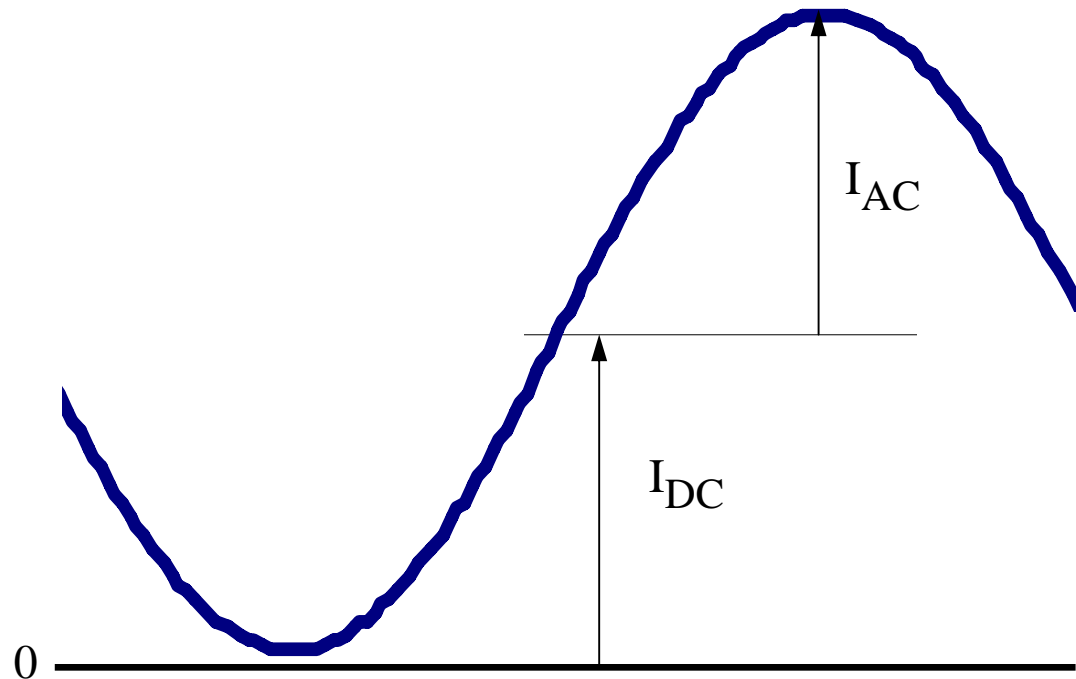

Multi-cell White Circuit (NINA, DESY & others)

For high voltage circuits, the magnets are segmented into a number of separate groups.

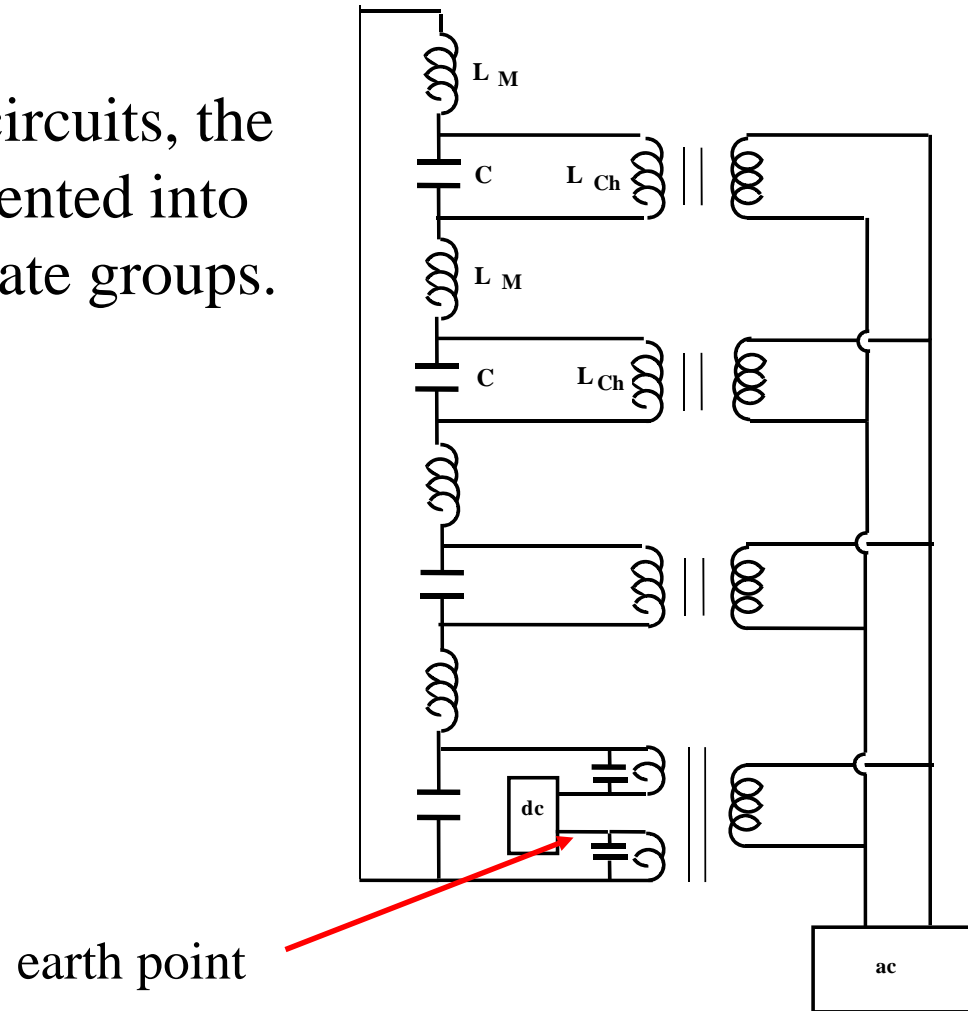

Multi-cell White circuit (cont.)

Benefits for an 'n' section circuit

- magnets are still in series for current continuity;
- voltage across each section is only $1/n$ of total;
- maximum voltage to earth is only $1/2n$ of total;
- choke has to be split into n sections;
- d.c. is at centre of one split section (earth point);
- a.c. is connected through a paralleled primary;
- the paralleled primary **must** be close coupled to secondary to balance voltages in the circuit;
- **still NO waveform control.**

Modern Capacitative Storage

Technical and economic developments in electrolytic capacitors manufacture now result in capacitative storage being lower cost than inductive energy storage (providing voltage reversal is not needed).

Also semi-conductor technology now allows the use of fully controlled devices (i.g.b.t. s) giving waveform control at medium current and voltages.

Medium sized synchrotrons with cycling times of 1 to 5 Hz can now take advantage of these developments for cheaper and dynamically controllable power magnet converters –

WAVEFORM CONTROL!

Example: Swiss Light Source Booster dipole circuit.

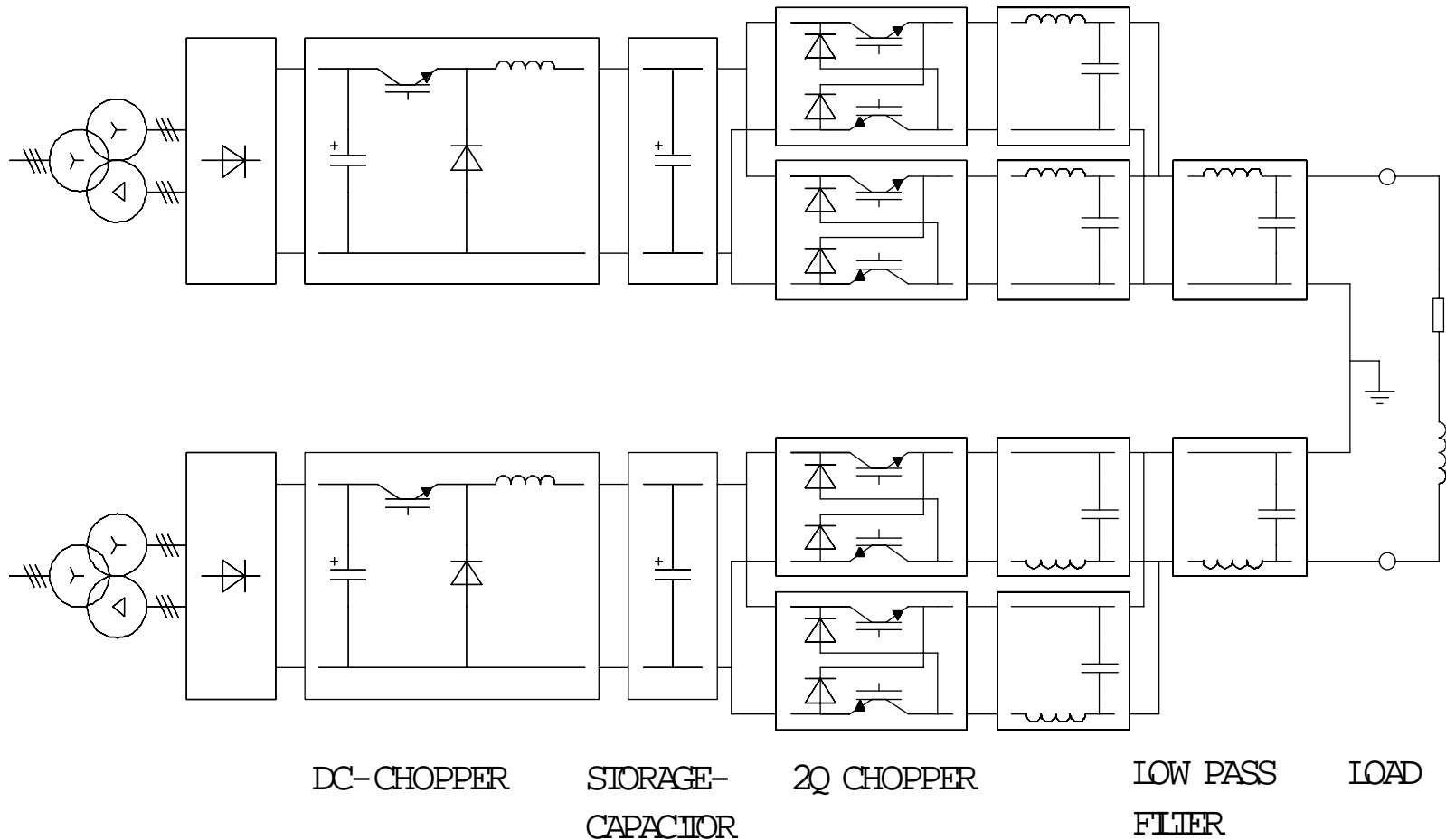

acknowledgment :Irminger, Horvat, Jenni, Boksberger, SLS

SLS Booster parameters

Combined function dipoles	48 BD 45 BF	
Resistance	600	m Ω
Inductance	80	mH
Max current	950	A
Stored energy	28	kJ
Cycling frequency	3	Hz

acknowledgment :Irminger, Horvat, Jenni, Boksberger, SLS

SLS Booster Waveforms

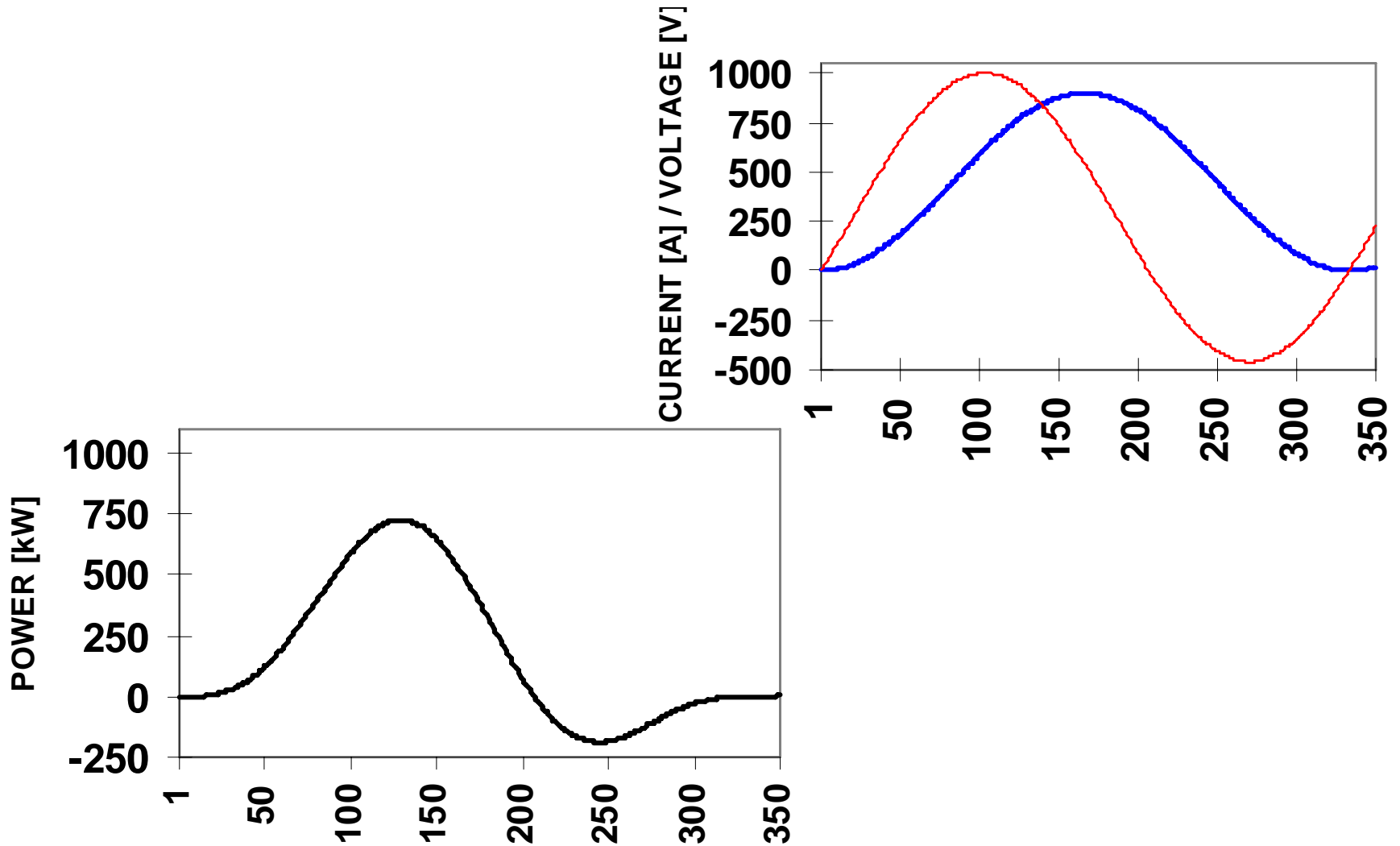

SLS Booster Waveforms

The storage capacitor only discharges a fraction of its stored energy during each acceleration cycle:

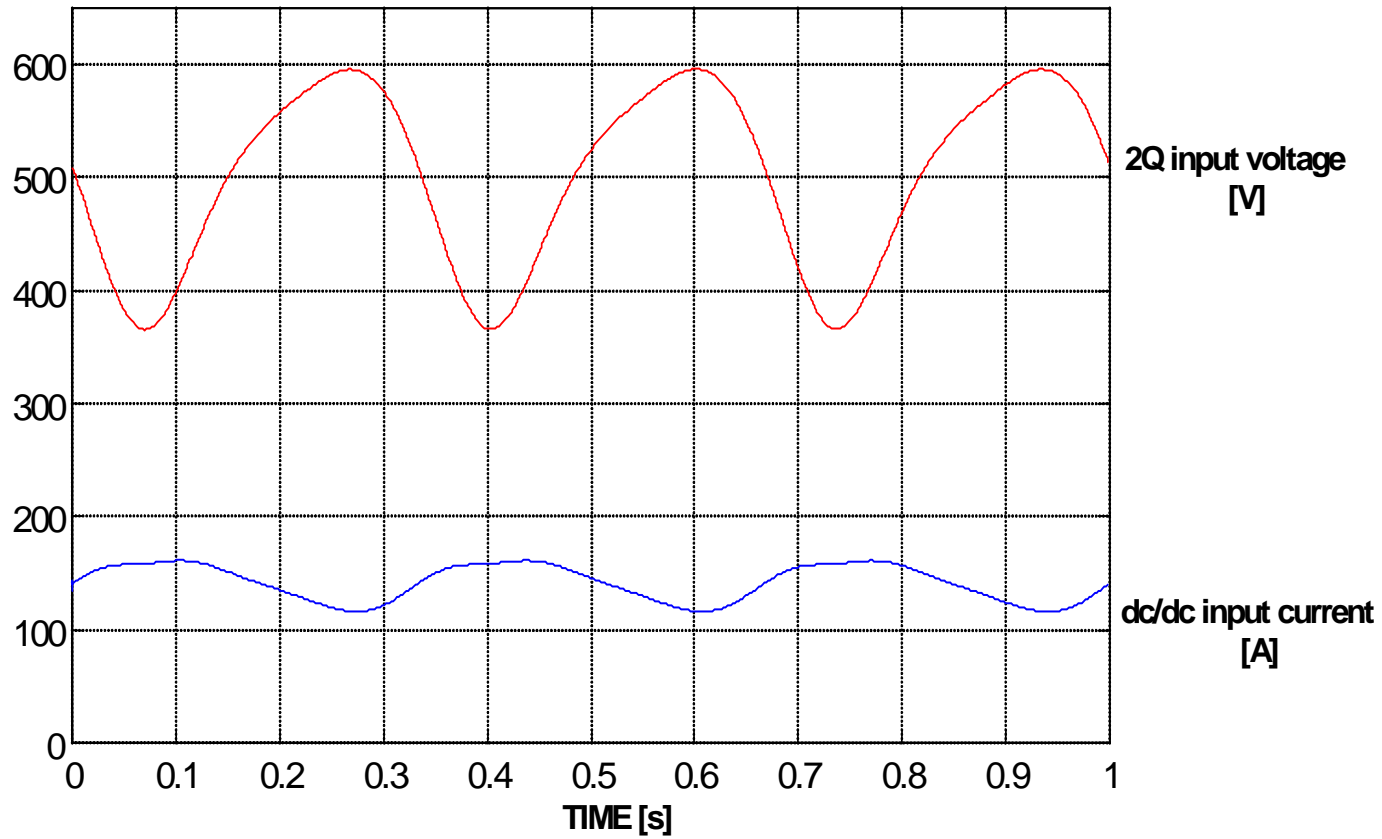

Assessment of switch-mode circuit

Comparison with the White Circuit:

- the s.m.circuit does not need a costly energy storage choke with increased power losses;
- within limits of rated current and voltage, the s.m.c. provides flexibility of output waveform;
- after switch on, the s.m.c. requires less than one second to stabilise (valuable in ‘top up mode’).

However:

- the current and voltages possible in switched circuits are restricted by component ratings.

Diamond Booster parameters for SLS type circuit

Parameter	low turns	high turns	
Number of turns per dipole:	16	20	
Peak current:	1271	1016	A
Total RMS current (for fully biased sine-wave):	778	622	A
Conductor cross section:	195	156	mm ²
Total ohmic loss:	188	188	kW
Inductance all dipoles in series:	0.091	0.142	H
Peak stored energy all dipoles:	73.3	73.3	kJ
Cycling frequency:	5	5	Hz
Peak reactive alternating volts across circuit:	1.81	2.26	kV

Note: the higher operating frequency; the 16 or 20 turn options were considered to adjust to the current/voltage ratings available from capacitors and semi-conductors; the low turns option was chosen and is now operational.

Delay-line mode of resonance

Most often seen in cycling circuits (high field disturbances produce disturbance at next injection); but can be present in any system.

Stray capacitance to earth makes the inductive magnet string a delay line. Travelling and standing waves (current and voltage) on the series magnet string: **different current in dipoles at different positions!**

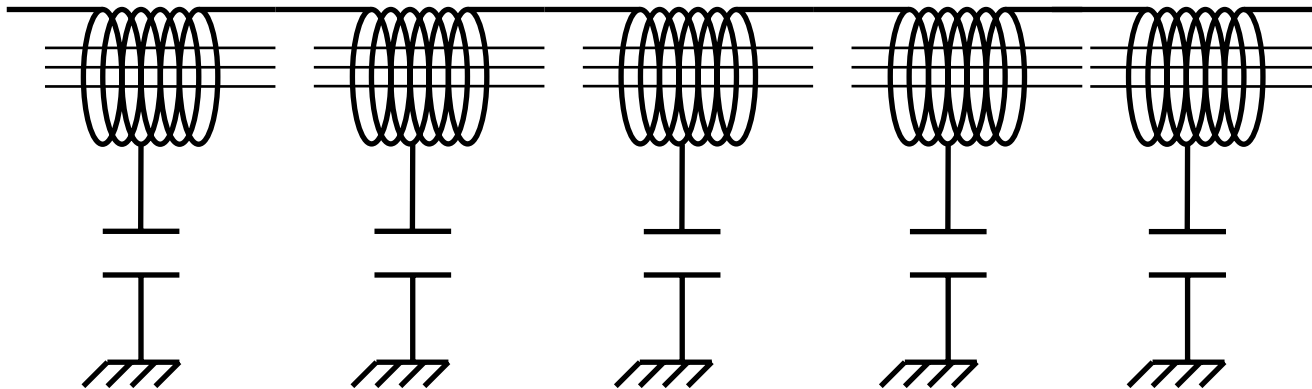

Standing waves on magnets series

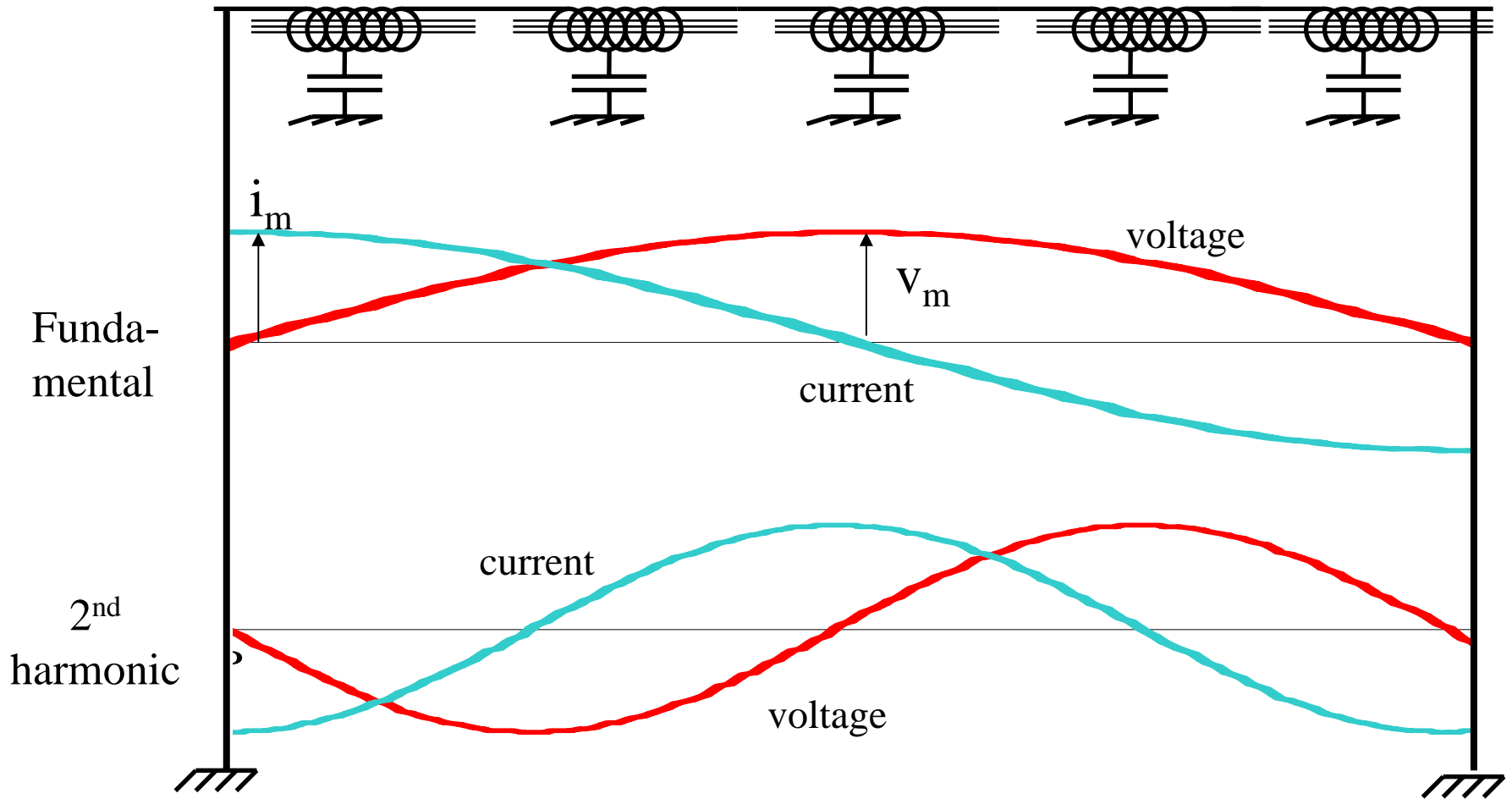

Delay-line mode equations

L_M is total magnet inductance;

C is total stray capacitance;

Then:

surge impedance:

$$Z = v_m/i_m = \sqrt{(L_M/C)};$$

transmission time:

$$\tau = \sqrt{(L_M C)};$$

fundamental frequency:

$$\omega_1 = 1/\{ 2 \sqrt{(L_M C)} \}$$

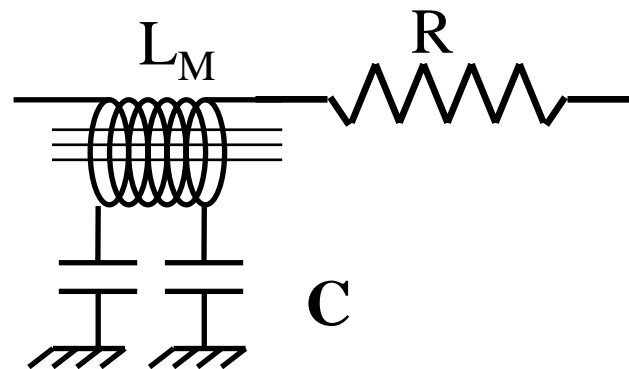

Excitation of d.l.m.r.

The mode will only be excited if rapid voltage-to-earth excursions are induced locally at high energy in the magnet chain ('beam-bumps'); the next injection is then compromised:

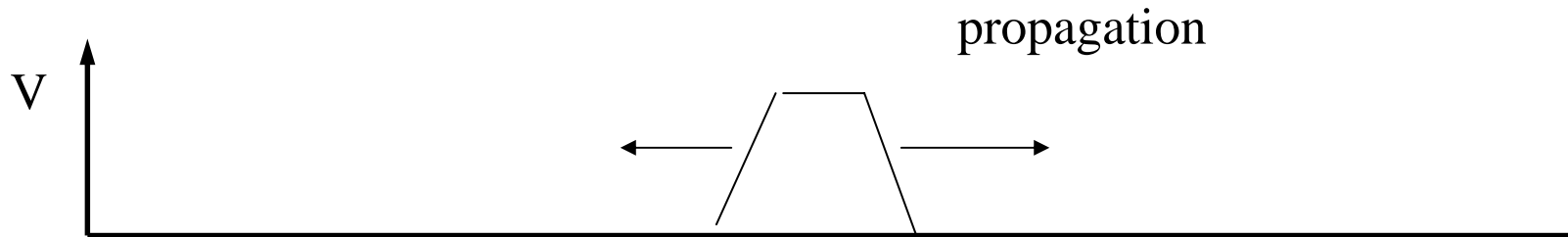

- keep stray capacitance as low as possible;
- avoid local disturbances in magnet ring;
- solutions (damping loops) are possible.