

# LONGITUDINAL DYNAMICS

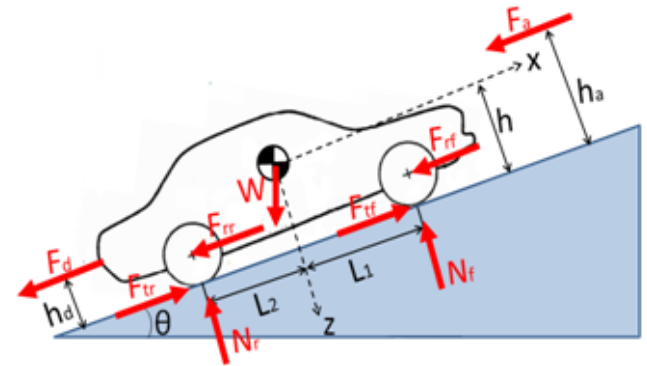

Frank Tecker  
CERN, BE-OP



Basics of Accelerator Science and Technology at CERN  
Chavannes de Bogis, 6-10 February 2017

# Summary of the 2 lectures:

- Acceleration methods
- Accelerating structures
- Linac: Phase Stability + Energy-Phase oscillations
- Circular accelerators: Cyclotron / Synchrotron
- Dispersion Effects in Synchrotron
- Stability and Longitudinal Phase Space Motion
- Injection Matching
- RF manipulations in the PS

## Two more related lectures:

- Linacs - Alessandra Lombardi
- RF Systems - myself

# The CERN Accelerator Complex

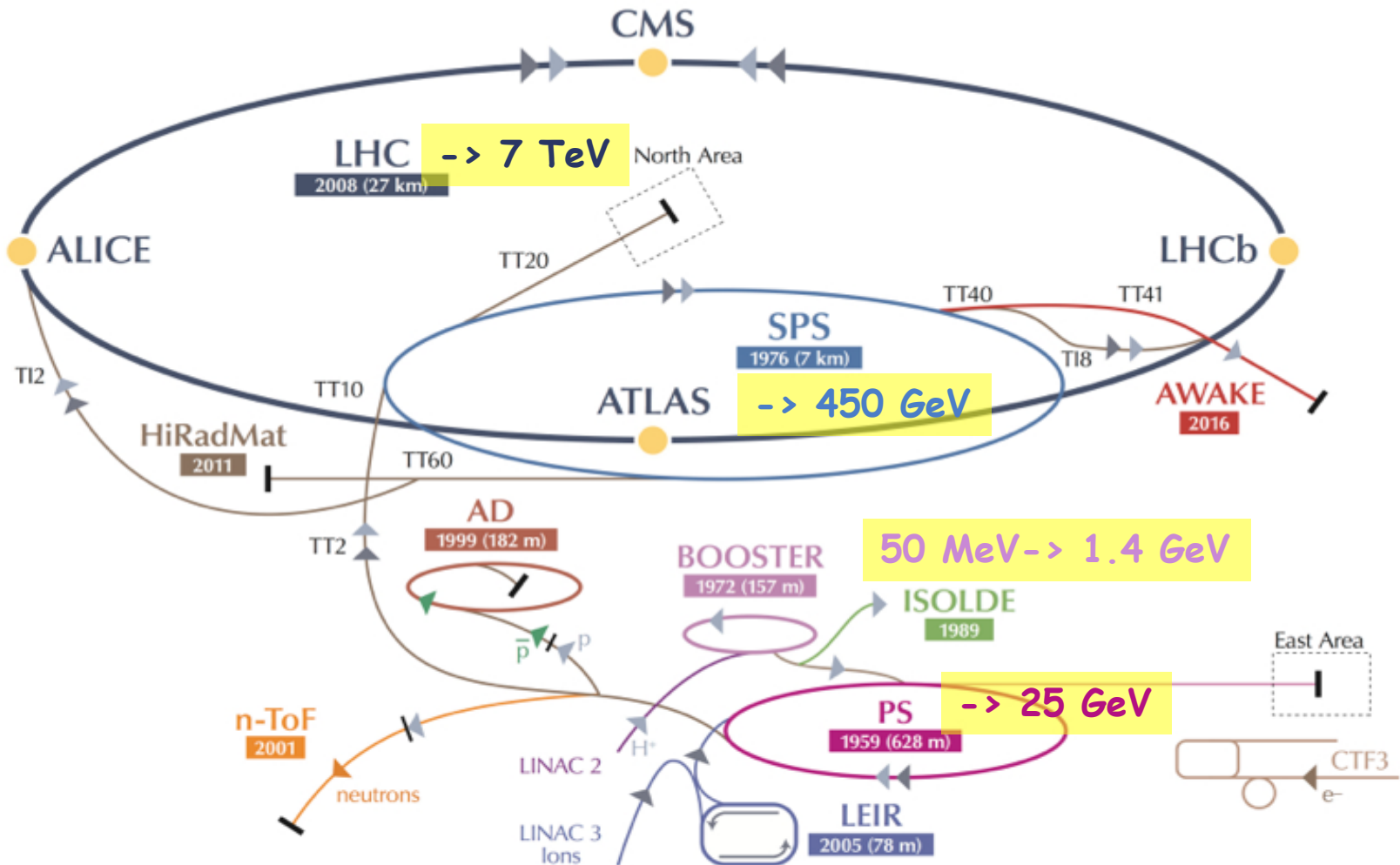

▶ p (proton)    ▶ ion    ▶ neutrons    ▶  $\bar{p}$  (antiproton)    ▶ electron    ▶  $\leftrightarrow$  proton/antiproton conversion

# Particle types and acceleration

The accelerating system will depend upon the **evolution** of the **particle velocity** along the system

- **electrons** reach a **constant velocity** at relatively low energy
- heavy particles reach a constant velocity only at very high energy  
-> we need different types of resonators,  
optimized for different velocities

Particle rest mass:

**electron** 0.511 MeV

**proton** 938 MeV

**<sup>239</sup>U** ~220000MeV

Relativistic  
gamma factor:

$$\gamma = \frac{E}{E_0} = \frac{m}{m_0}$$

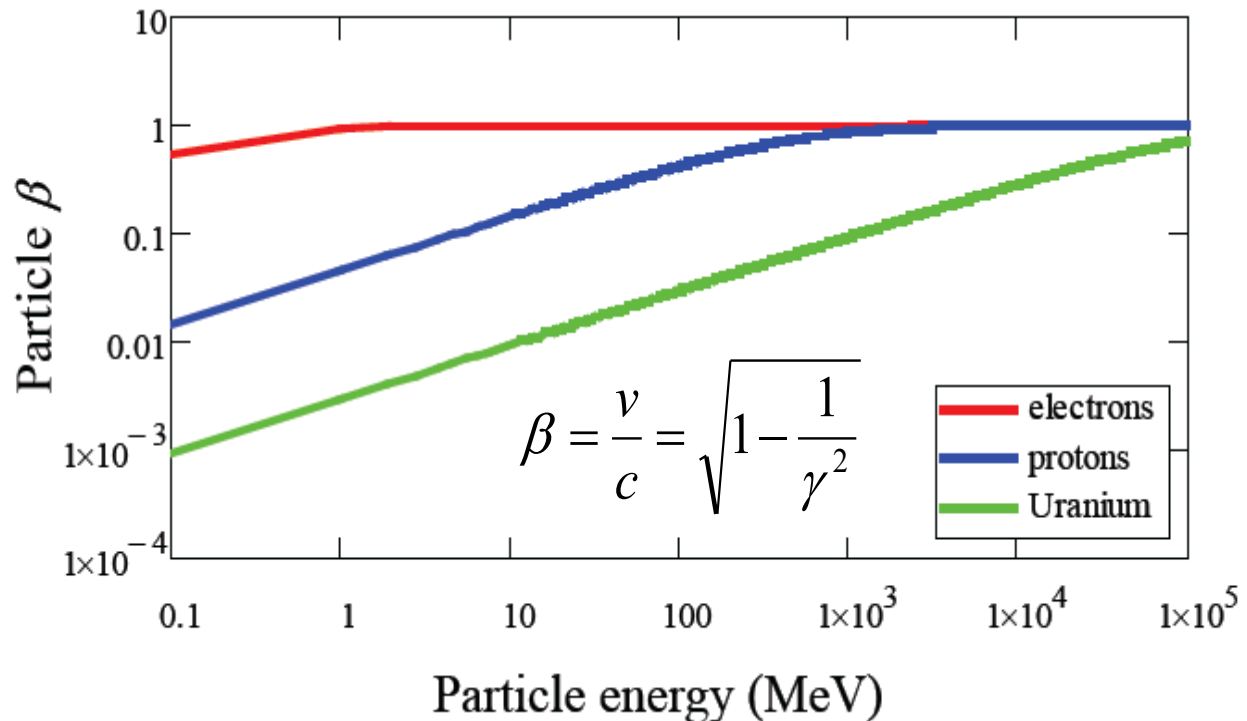



# Velocity, Energy and Momentum

normalized velocity  $\beta = \frac{v}{c} = \sqrt{1 - \frac{1}{\gamma^2}}$

=> electrons almost reach the speed of light very quickly (few MeV range)

total energy  
rest energy

$$E = \gamma m_0 c^2$$

$$\gamma = \frac{E}{E_0} = \frac{m}{m_0} = \frac{1}{\sqrt{1 - \frac{v^2}{c^2}}} = \frac{1}{\sqrt{1 - \beta^2}}$$

Momentum  $p = mv = \frac{E}{c^2} \beta c = \beta \frac{E}{c} = \beta \gamma m_0 c$

=> Magnetic field needs to follow the momentum increase

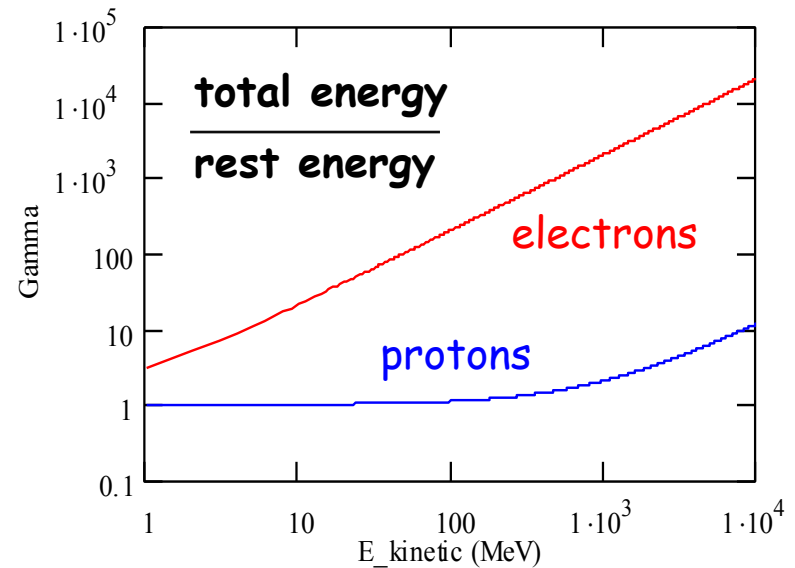
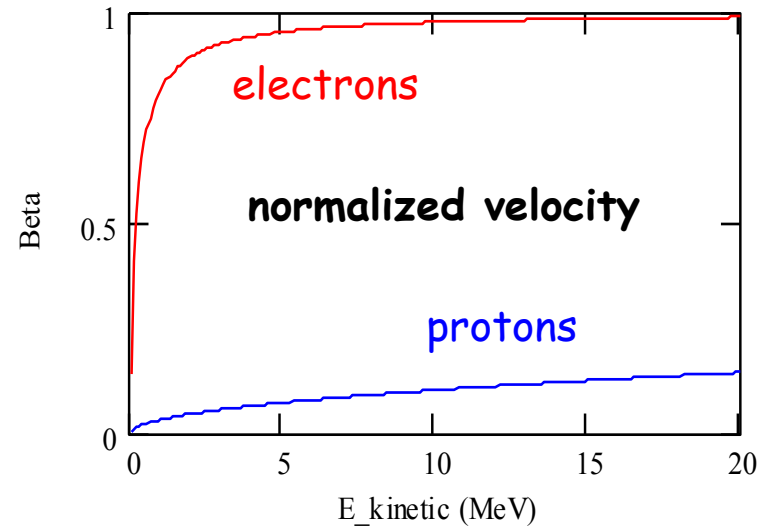

# Acceleration: May the force be with you



To accelerate, we need a **force in the direction of motion!**

Newton-Lorentz Force  
on a charged particle:

$$\vec{F} = \frac{d\vec{p}}{dt} = e \left( \vec{E} + \vec{v} \times \vec{B} \right)$$

2<sup>nd</sup> term always perpendicular  
to motion => **no acceleration**

Hence, it is necessary to have an **electric field E**  
(preferably) **along the direction of the initial momentum (z)**,  
which changes the momentum of the particle.

$$\frac{dp}{dt} = eE_z$$

The 2<sup>nd</sup> term - larger at high velocities - is used for:

- **BENDING**: generated by a magnetic field perpendicular to the plane of the  
particle trajectory. The bending radius  $\rho$  obeys to the relation :

$$\frac{p}{e} = B\rho$$

in practical units:  $B \rho [\text{Tm}] \approx \frac{p [\text{GeV}/c]}{0.3}$

- **FOCUSING**: the bending effect is used to bring the particles trajectory  
closer to the axis, hence to increase the beam density.

# Energy Gain

The acceleration increases the **momentum**, providing **kinetic energy** to the charged particles.

In relativistic dynamics, total **energy**  $E$  and **momentum**  $p$  are **linked by**

$$E^2 = E_0^2 + p^2 c^2 \quad (E = E_0 + W) \quad W \text{ kinetic energy}$$

Hence:  $dE = v dp$   $(2E dE = 2c^2 p dp \Leftrightarrow dE = c^2 mv / E dp = v dp)$

The rate of **energy gain per unit length** of acceleration (along  $z$ ) is then:

$$\frac{dE}{dz} = v \frac{dp}{dz} = \frac{dp}{dt} = eE_z$$

and the kinetic **energy gained** from the field along the  $z$  path is:

$$dW = dE = eE_z dz \quad \rightarrow \quad W = e \int E_z dz = eV$$

where  $V$  is just a potential.

# Unit of Energy

Today's accelerators and future projects work/aim at the **TeV energy** range.

LHC: 7 TeV -> 14 TeV

CLIC: 3 TeV

HE/VHE-LHC: 33/100 TeV

In fact, this energy unit comes from acceleration:

**1 eV (electron Volt)** is the energy that 1 elementary charge  $e$  (like one electron or proton) gains when it is accelerated in a potential (voltage) difference of 1 Volt.

**Basic Unit: eV (electron Volt)**

keV = 1000 eV =  $10^3$  eV

MeV =  $10^6$  eV

GeV =  $10^9$  eV

TeV =  $10^{12}$  eV

LHC = ~450 Million km of batteries!!!  
3x distance Earth-Sun

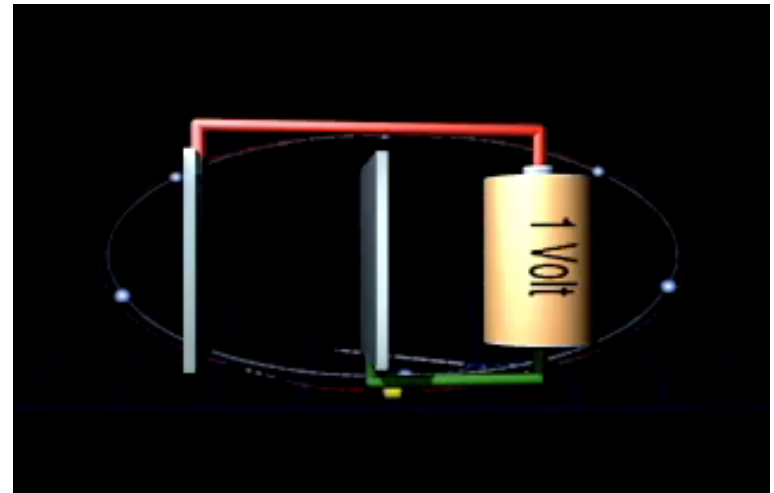

# Electrostatic Acceleration

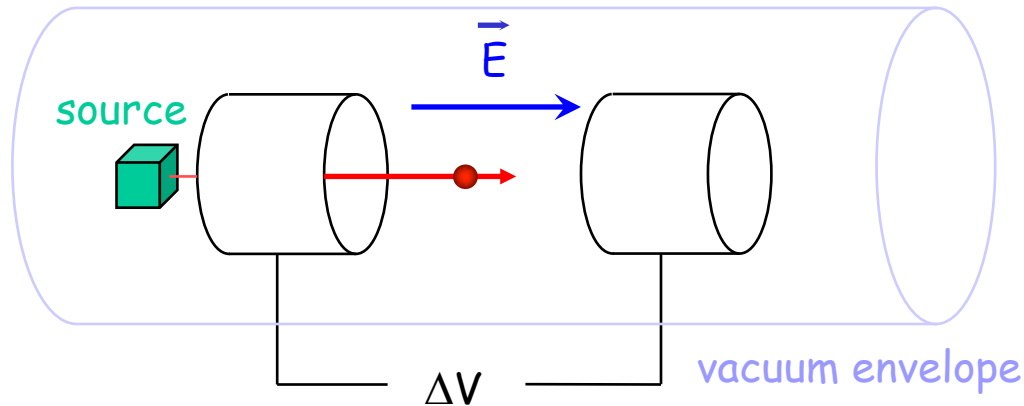

## Electrostatic Field:

$$\text{Force: } \vec{F} = \frac{d\vec{p}}{dt} = e \vec{E}$$

$$\text{Energy gain: } W = e \Delta V$$

used for first stage of acceleration:  
particle sources, electron guns,  
x-ray tubes

Limitation: **insulation problems**  
maximum high voltage ( $\sim 10$  MV)

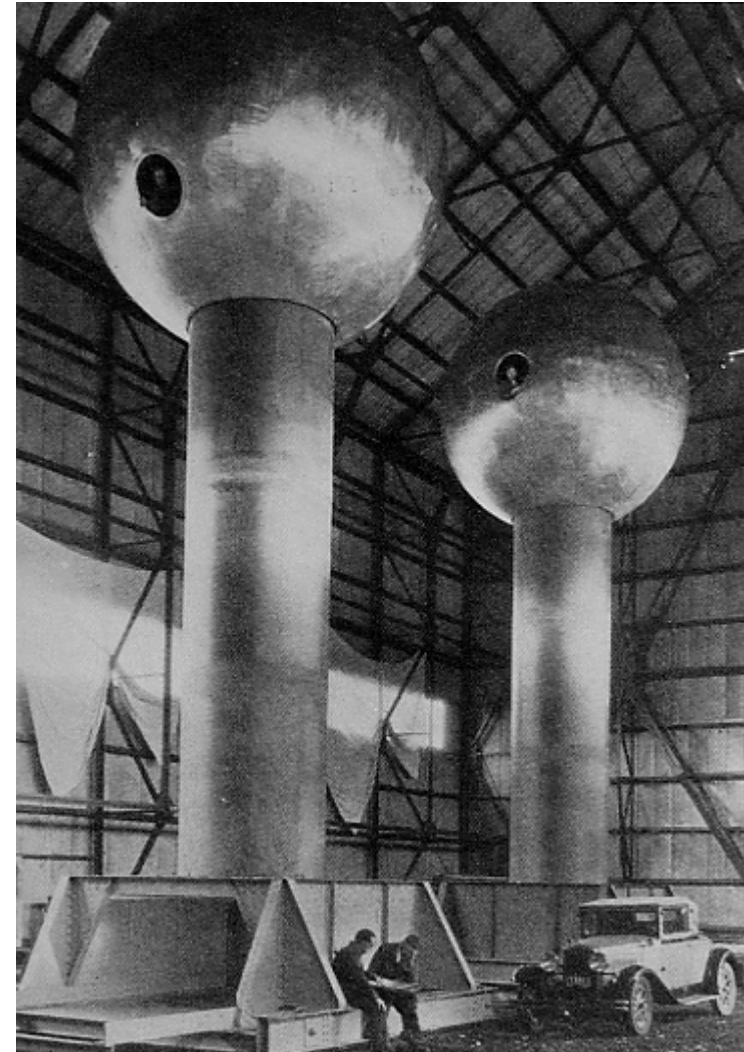

Van-de-Graaf generator at MIT

# Methods of Acceleration: Time varying fields

Electrostatic field is limited by insulation problems, the magnetic field does not accelerate at all.

Circular machine: DC acceleration impossible since  $\oint \vec{E} \cdot d\vec{s} = 0$

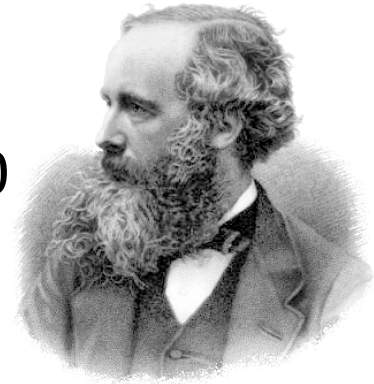

From Maxwell's Equations:  $\vec{E} = -\vec{\nabla}\phi - \frac{\partial \vec{A}}{\partial t}$

$$\vec{B} = \mu\vec{H} = \vec{\nabla} \times \vec{A} \quad \text{or} \quad \nabla \times \vec{E} = -\frac{\partial \vec{B}}{\partial t}$$

The electric field is derived from a scalar potential  $\phi$  and a vector potential  $A$   
The **time variation of the magnetic field  $H$  generates an electric field  $E$**

The **solution**: => **time varying electric fields**

- Induction
- RF frequency fields

$$\oint \vec{E} \cdot d\vec{s} = - \iint \frac{\partial \vec{B}}{\partial t} \cdot d\vec{A}$$

Consequence: We can **only** accelerate **bunched beam**!

# Acceleration by Induction: The Betatron

It is based on the principle of a **transformer**:

- **primary side**: large electromagnet    - **secondary side**: electron beam.

The ramping magnetic field is used to guide particles on a circular trajectory as well as for acceleration.

Limited by saturation in iron (~300 MeV e-)

Used in industry and medicine, as they are compact accelerators for electrons



Donald Kerst with the first betatron, invented at the University of Illinois in 1940

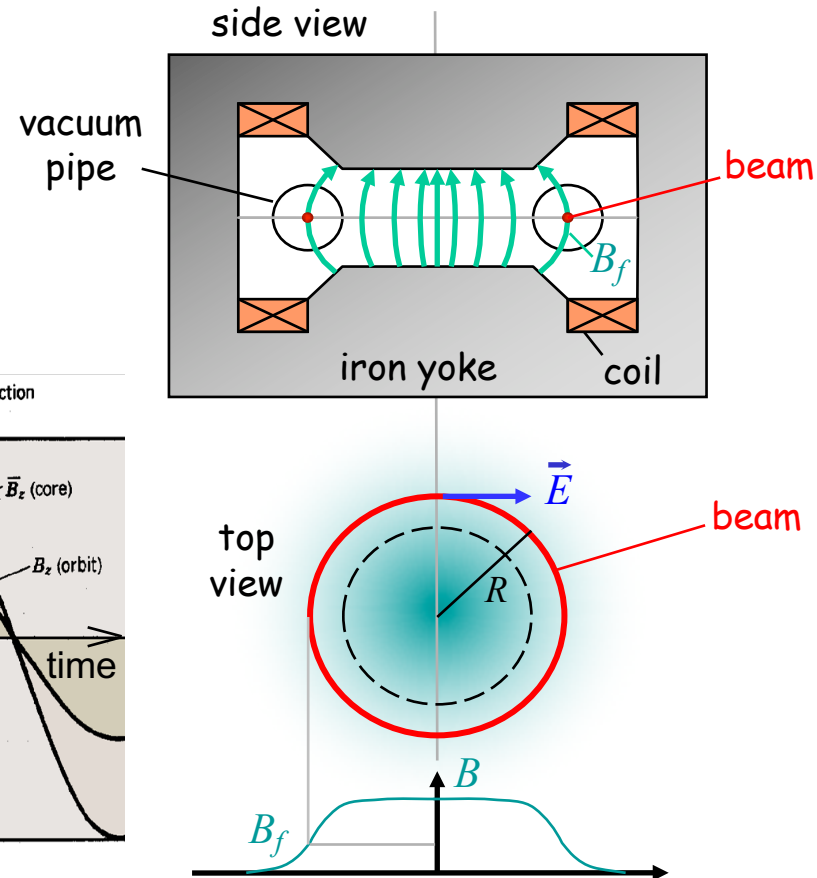
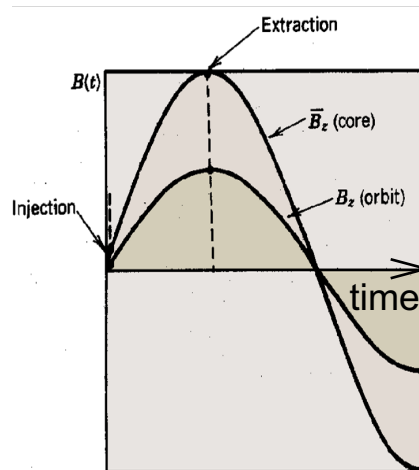



# Radio-Frequency (RF) Acceleration

Electrostatic acceleration limited by isolation possibilities => use **RF** fields

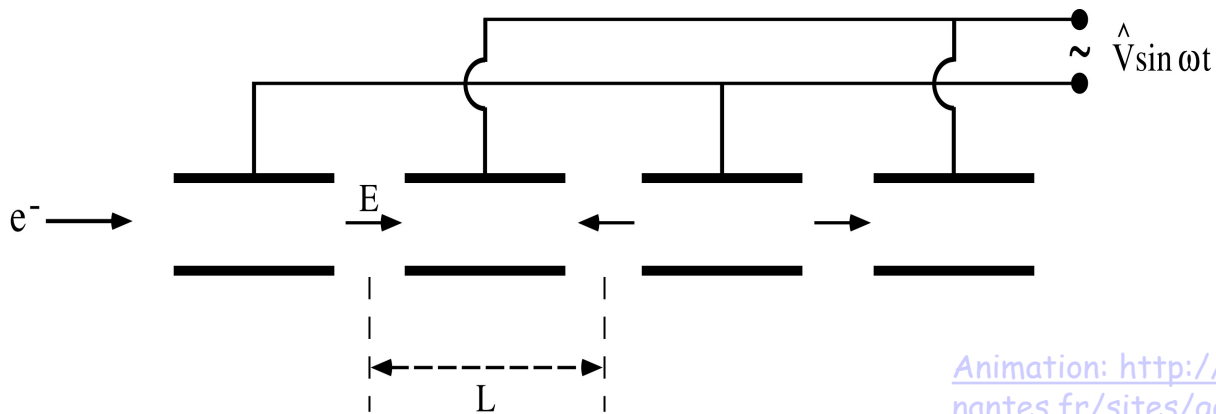

Widerøe-type structure

Animation: [http://www.sciences.univ-nantes.fr/sites/genevieve\\_tulloue/Meca/Charges/linac.html](http://www.sciences.univ-nantes.fr/sites/genevieve_tulloue/Meca/Charges/linac.html)

Cylindrical electrodes (**drift tubes**) separated by gaps and fed by a **RF generator**, as shown above, lead to an alternating electric field polarity

Synchronism condition  $\longrightarrow L = v T/2$

$v$  = particle velocity  
 $T$  = RF period

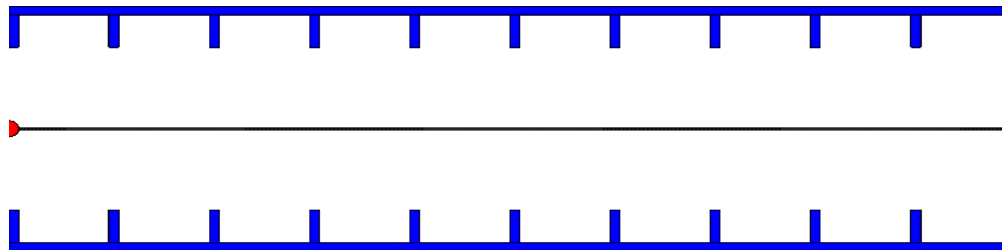

Similar for standing wave cavity as shown (with  $v \approx c$ )



# Resonant RF Cavities

- Considering RF acceleration, it is obvious that when particles get high velocities the drift spaces get longer and one loses on the efficiency.  
=> The solution consists of using a **higher operating frequency**.
- The **power lost** by radiation, due to circulating currents on the electrodes, is **proportional to the RF frequency**.  
=> The solution consists of **enclosing the system in a cavity** which resonant frequency matches the RF generator frequency.

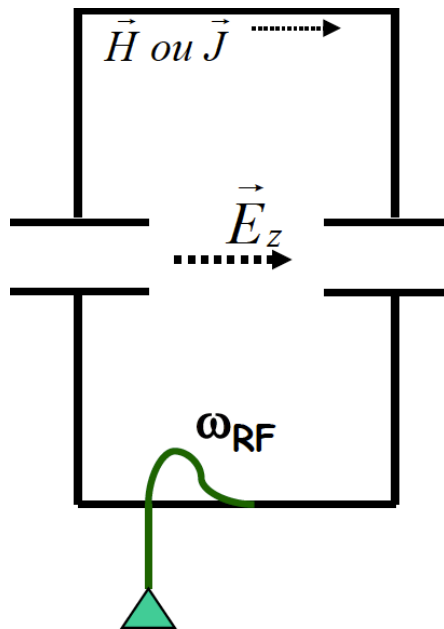

- The electromagnetic power is now constrained in the resonant volume
- Each such cavity can be independently powered from the RF generator
- Note however that joule losses will occur in the cavity walls (unless made of superconducting materials)

# Some RF Cavity Examples

$L = vT/2$  ( $\pi$  mode)

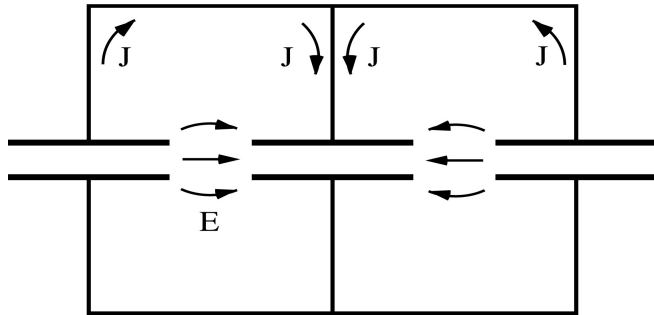

$L = vT$  ( $2\pi$  mode)

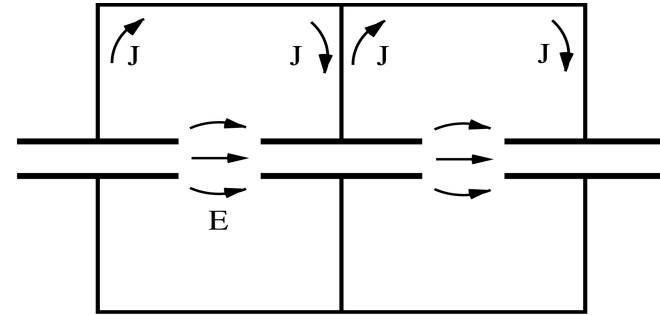

Single Gap More in RF Systems

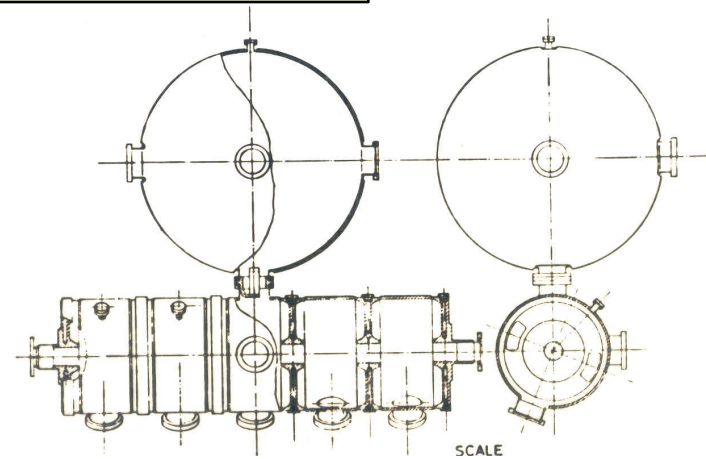
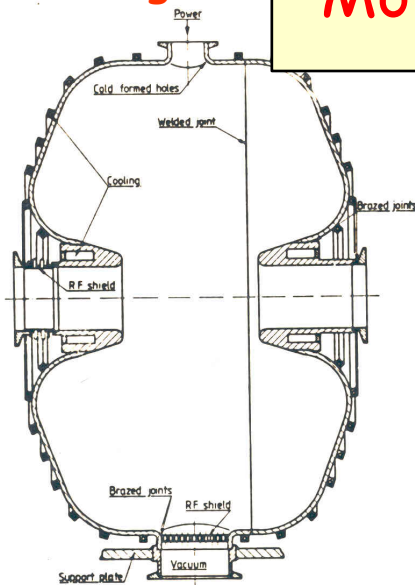

# RF acceleration: Alvarez Structure

$g$

Used for protons, ions (50 - 200 MeV,  $f \sim 200$  MHz)

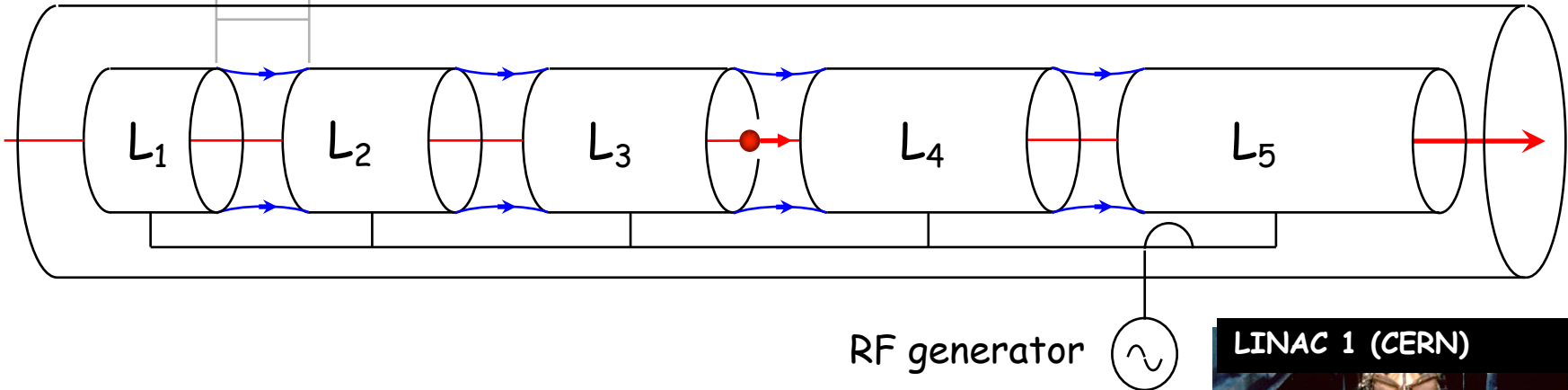

Synchronism condition ( $g \ll L$ )



$$L = v_s T_{RF} = \beta_s \lambda_{RF}$$

$$\omega_{RF} = 2\pi \frac{v_s}{L}$$

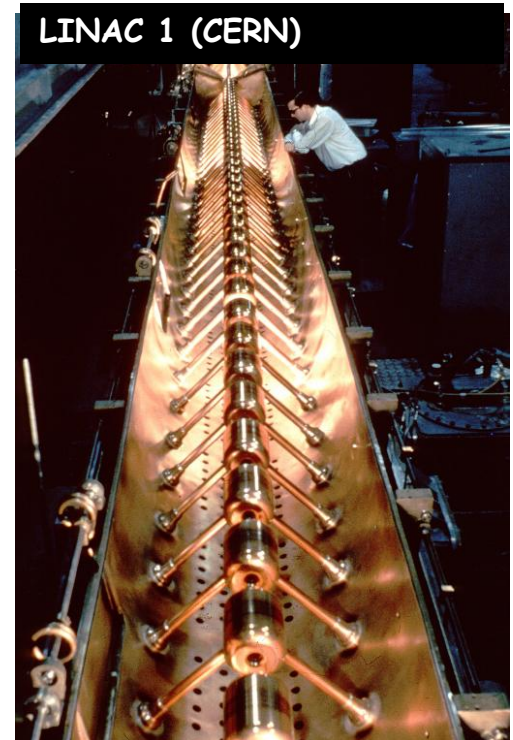

# Summary: Relativity + Energy Gain

**Newton-Lorentz Force**  $\vec{F} = \frac{d\vec{p}}{dt} = e \left( \vec{E} + \vec{v} \times \vec{B} \right)$

2<sup>nd</sup> term always perpendicular to motion => no acceleration

## Relativistic Dynamics

$$\beta = \frac{v}{c} = \sqrt{1 - \frac{1}{\gamma^2}} \quad \gamma = \frac{E}{E_0} = \frac{m}{m_0} = \frac{1}{\sqrt{1 - \beta^2}}$$

$$p = mv = \frac{E}{c^2} \beta c = \beta \frac{E}{c} = \beta \gamma m_0 c$$

$$E^2 = E_0^2 + p^2 c^2 \quad \longrightarrow \quad dE = v dp$$

$$\frac{dE}{dz} = v \frac{dp}{dz} = \frac{dp}{dt} = e E_z$$

$$dE = dW = e E_z dz \quad \rightarrow \quad W = e \int E_z dz$$

## RF Acceleration

$$E_z = \hat{E}_z \sin \omega_{RF} t = \hat{E}_z \sin \phi(t)$$

$$\int \hat{E}_z dz = \hat{V}$$

$$W = e \hat{V} \sin \phi$$

**(neglecting transit time factor)**

The field will change during the passage of the particle through the cavity  
=> effective energy gain is lower

# Common Phase Conventions

1. For **circular accelerators**, the origin of time is taken at the **zero crossing** of the RF voltage with positive slope
2. For **linear accelerators**, the origin of time is taken at the positive **crest** of the RF voltage

Time  $t=0$  chosen such that:

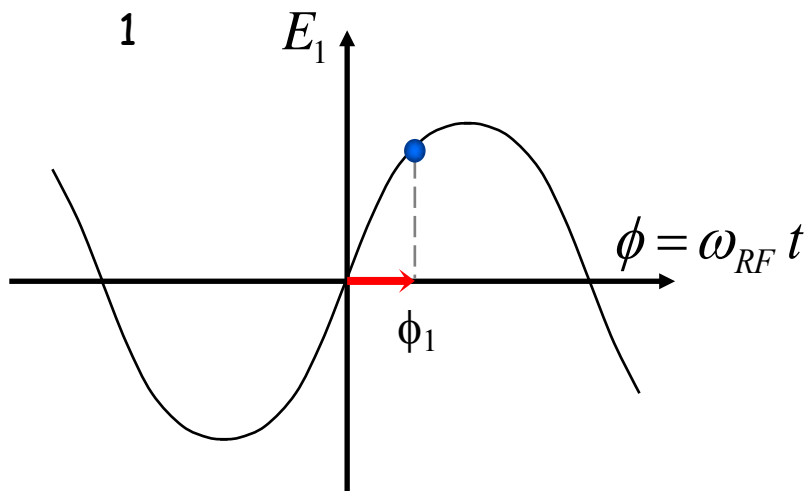

$$E_1(t) = E_0 \sin(\omega_{RF} t)$$

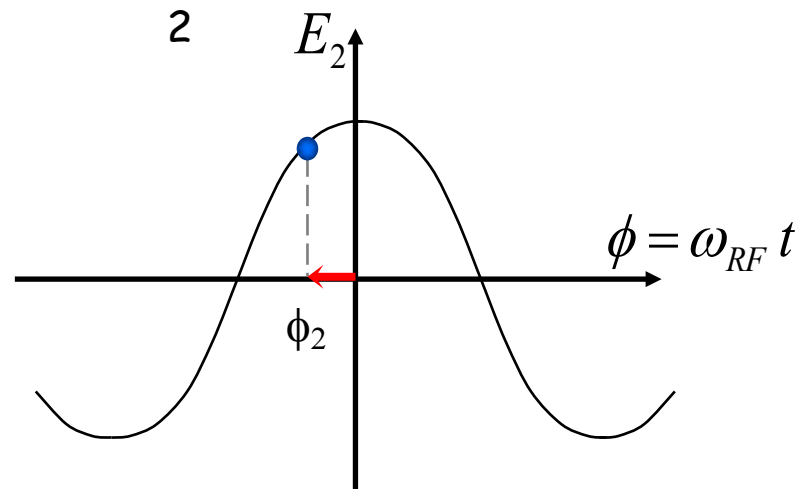

$$E_2(t) = E_0 \cos(\omega_{RF} t)$$

3. I will stick to **convention 1** in the following to avoid confusion

# Principle of Phase Stability (Linac)

Let's consider a succession of accelerating gaps, operating in the  $2\pi$  mode, for which the synchronism condition is fulfilled for a phase  $\Phi_s$ .

$eV_s = e\hat{V} \sin \Phi_s$  is the energy gain in one gap for the particle to reach the next gap with the same RF phase:  $P_1, P_2, \dots$  are fixed points.

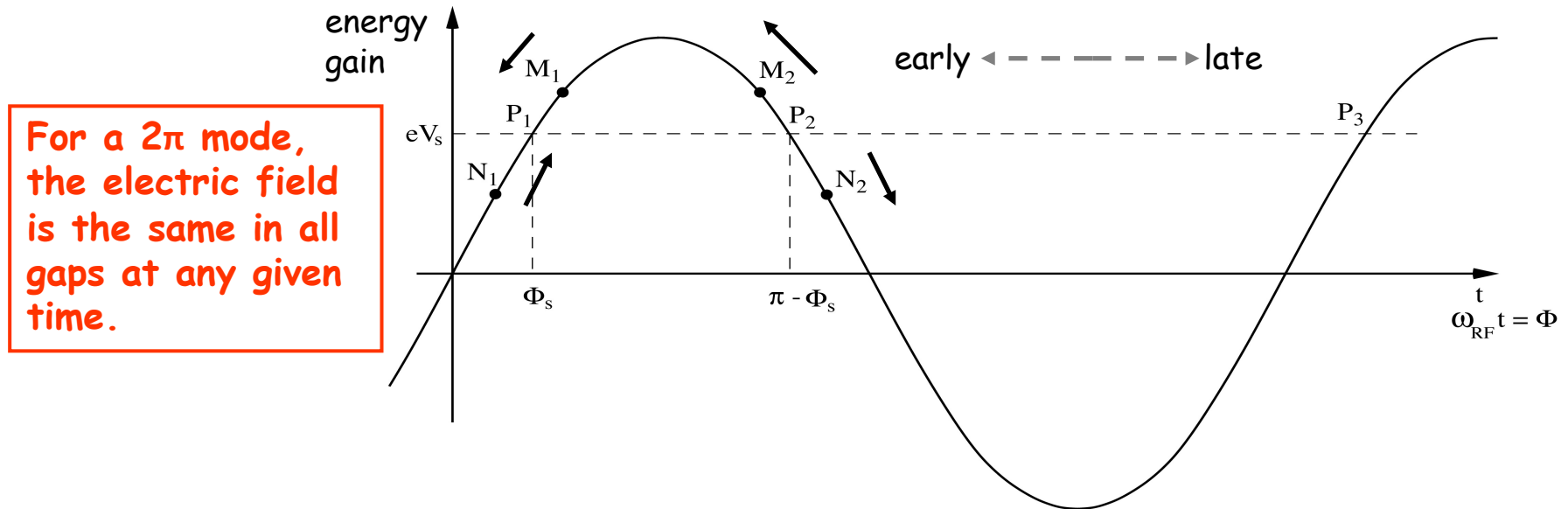

For a  $2\pi$  mode, the electric field is the same in all gaps at any given time.

If an **energy increase** is transferred into a **velocity increase**  $\Rightarrow$

$M_1$  &  $N_1$  will move towards  $P_1$   $\Rightarrow$  **stable**

$M_2$  &  $N_2$  will go away from  $P_2$   $\Rightarrow$  **unstable**

(Highly relativistic particles have no significant velocity change)

# A Consequence of Phase Stability

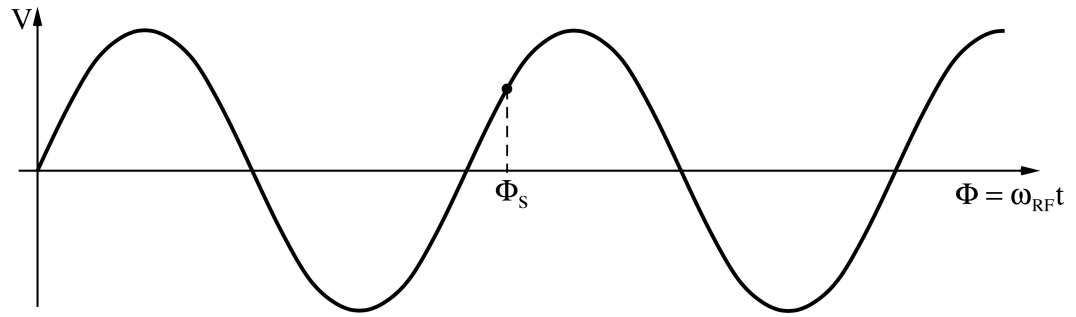
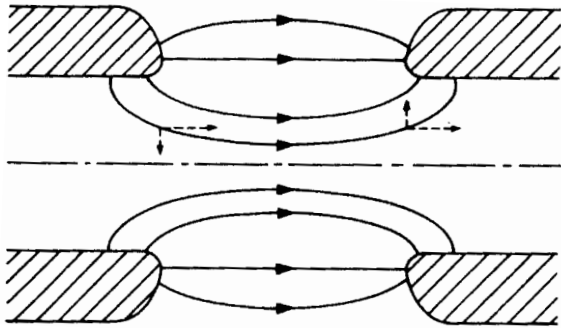

The divergence of the field is zero according to Maxwell :

$$\nabla \vec{E} = 0 \Rightarrow \frac{\partial E_x}{\partial x} + \frac{\partial E_z}{\partial z} = 0 \Rightarrow \frac{\partial E_x}{\partial x} = - \frac{\partial E_z}{\partial z}$$

Transverse fields

- **focusing** at the **entrance** and
- **defocusing** at the **exit** of the cavity.

Electrostatic case: Energy gain inside the cavity leads to focusing

RF case:

**Field increases during passage => transverse defocusing!**

**External focusing (solenoid, quadrupole) is then necessary**

# Energy-phase Oscillations (Small Amplitude) (1)

- Rate of **energy gain** for the **synchronous particle**:

$$\frac{dE_s}{dz} = \frac{dp_s}{dt} = eE_0 \sin \phi_s$$

- Rate of **energy gain** for a **non-synchronous particle**, expressed in **reduced variables**,  $w = W - W_s = E - E_s$  and  $\varphi = \phi - \phi_s$  :

$$\frac{dw}{dz} = eE_0 [\sin(\phi_s + \varphi) - \sin \phi_s] \approx eE_0 \cos \phi_s \cdot \varphi \quad (\text{small } \varphi)$$

- Rate of change of the **phase** with respect to the synchronous one:

$$\frac{d\varphi}{dz} = \omega_{RF} \left( \frac{dt}{dz} - \left( \frac{dt}{dz} \right)_s \right) = \omega_{RF} \left( \frac{1}{v} - \frac{1}{v_s} \right) \approx -\frac{\omega_{RF}}{v_s^2} (v - v_s)$$

Leads finally to:

$$\frac{d\varphi}{dz} = -\frac{\omega_{RF}}{m_0 v_s^3 \gamma_s^3} w$$



# Energy-phase Oscillations (Small Amplitude) (2)

Combining the two 1<sup>st</sup> order equations into a 2<sup>nd</sup> order equation gives the equation of a **harmonic oscillator**:

$$\frac{d^2 \phi}{dz^2} + \Omega_s^2 \phi = 0$$

with

$$\Omega_s^2 = \frac{eE_0 \omega_{RF} \cos \phi_s}{m_0 v_s^3 \gamma_s^3}$$

Slower for higher energy!

Stable harmonic oscillations imply:

$$\Omega_s^2 > 0 \quad \text{and real}$$

hence:  $\cos \phi_s > 0$

And since acceleration also means:

$$\sin \phi_s > 0$$

You finally get the result for the **stable phase range**:

$$0 < \phi_s < \frac{\pi}{2}$$

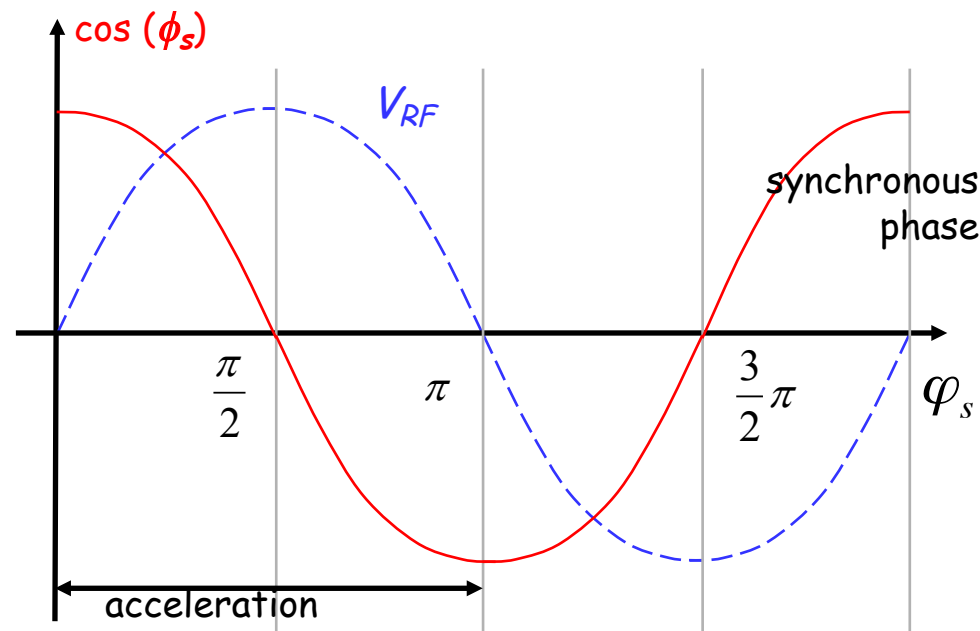

# Longitudinal phase space

The **energy - phase oscillations** can be drawn in **phase space**:

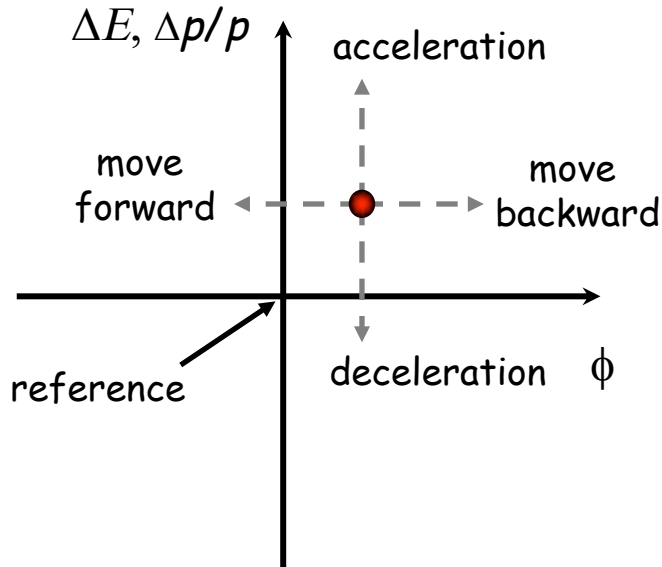

The particle trajectory in the phase space ( $\Delta p/p, \phi$ ) describes its longitudinal motion.

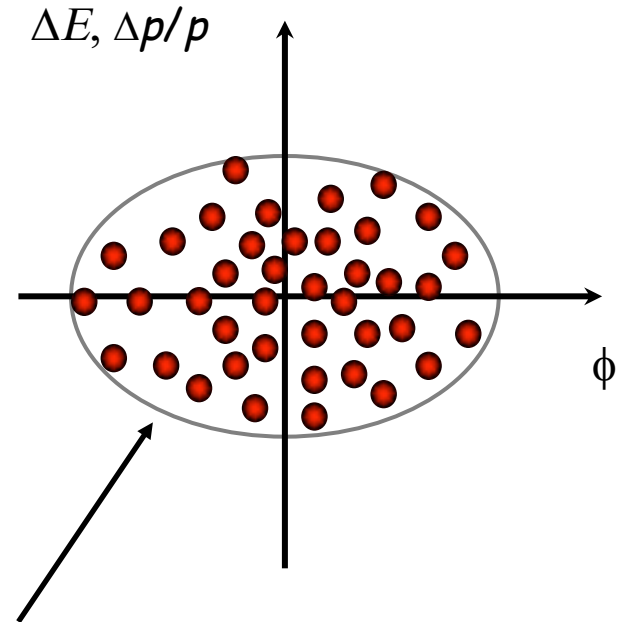

Emittance: phase space area including all the particles

NB: if the emittance contour correspond to a possible orbit in phase space, its shape does not change with time (matched beam)

## Summary up to here...

- **Acceleration by electric fields**, static fields limited  
=> time-varying fields
- **Synchronous condition** needs to be fulfilled for acceleration
- Particles perform **oscillation** around synchronous phase
- visualize oscillations in phase space
  
- Electrons are quickly relativistic, speed does not change  
use traveling wave structures for acceleration
- Protons and ions need changing structure geometry

# Circular accelerators

Cyclotron  
Synchrotron

## Circular accelerators: Cyclotron



Courtesy: EdukiteLearning, <https://youtu.be/cNnNM2ZqIsc>

# Circular accelerators: Cyclotron

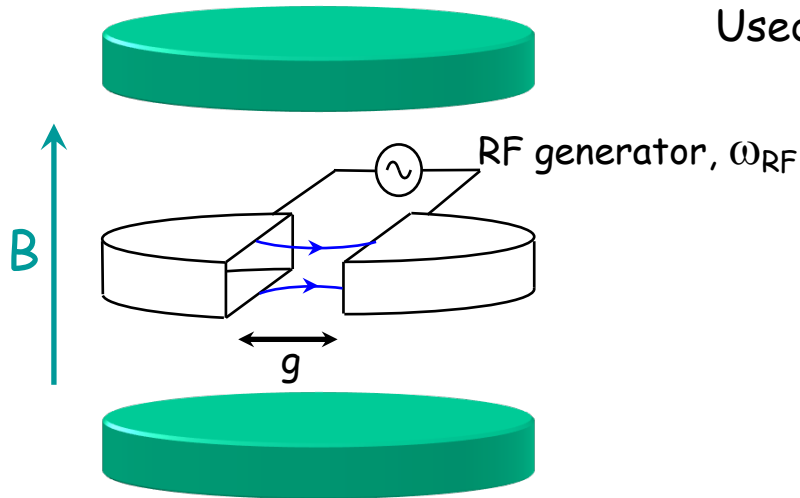

Synchronism condition



$$\omega_s = \omega_{RF}$$

$$2\pi \rho = v_s T_{RF}$$

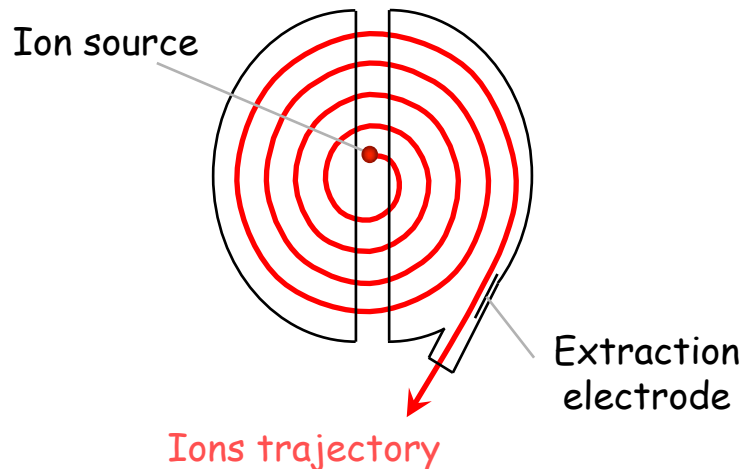

Cyclotron frequency  $\omega = \frac{q B}{m_0 \gamma}$

1.  $\gamma$  increases with the energy  
 $\Rightarrow$  no exact synchronism
2. if  $v \ll c \Rightarrow \gamma \cong 1$

[Cyclotron Animation](#)

Animation: [http://www.sciences.univ-nantes.fr/sites/genevieve\\_tulloue/Meca/Charges/cyclotron.html](http://www.sciences.univ-nantes.fr/sites/genevieve_tulloue/Meca/Charges/cyclotron.html)

## Circular accelerators: Cyclotron



Courtesy Berkeley Lab,  
<https://www.youtube.com/watch?v=cutKuFxeXmQ>

CAS@CERN, 6-10 February 2017

# Cyclotron / Synchrocyclotron



TRIUMF 520 MeV cyclotron

Vancouver - Canada



CERN 600 MeV synchrocyclotron

**Synchrocyclotron:** Same as cyclotron, except a modulation of  $\omega_{RF}$

$B$  = constant

$\gamma \omega_{RF}$  = constant

$\omega_{RF}$  decreases with time

The condition:

$$\omega_s(t) = \omega_{RF}(t) = \frac{q B}{m_0 \gamma(t)}$$

Allows to go beyond the non-relativistic energies



# Circular accelerators: The Synchrotron

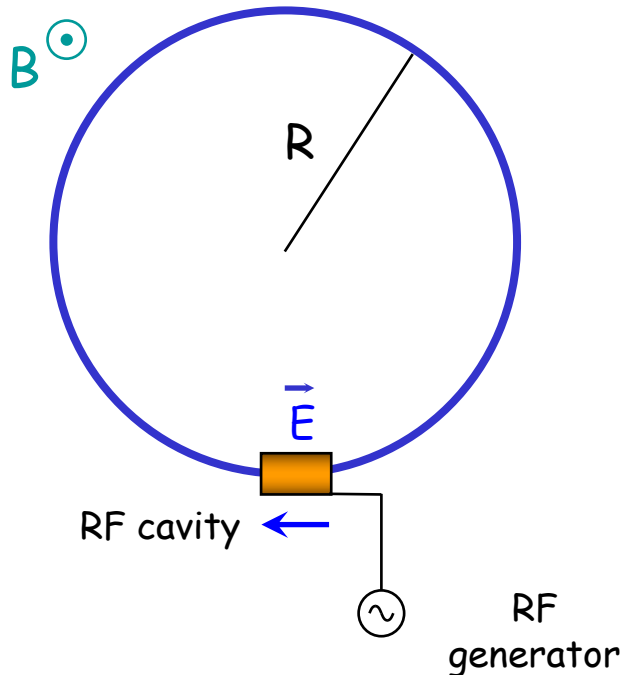

1. **Constant orbit** during acceleration
2. To keep particles on the closed orbit,  **$B$  should increase** with time
3.  **$\omega$  and  $\omega_{RF}$  increase** with energy

RF frequency can be multiple of revolution frequency

$$\omega_{RF} = h\omega$$

Synchronism condition



$$T_s = h T_{RF}$$

$$\frac{2\pi R}{v_s} = h T_{RF}$$

$h$  integer,  
**harmonic number:**  
 number of RF cycles  
 per revolution

# Circular accelerators: The Synchrotron

LEAR (CERN)  
Low Energy Antiproton Ring

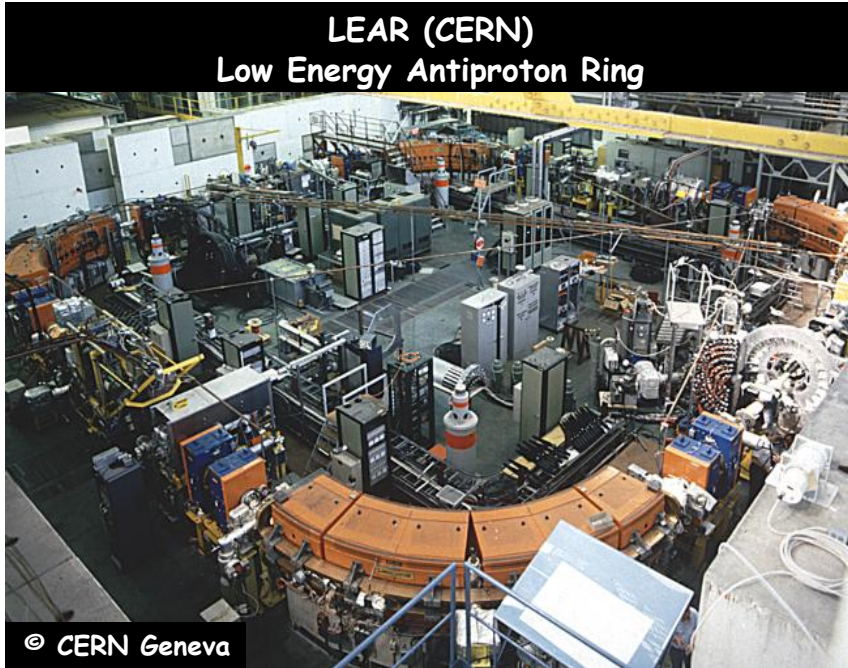

© CERN Geneva

EPA (CERN)  
Electron Positron Accumulator

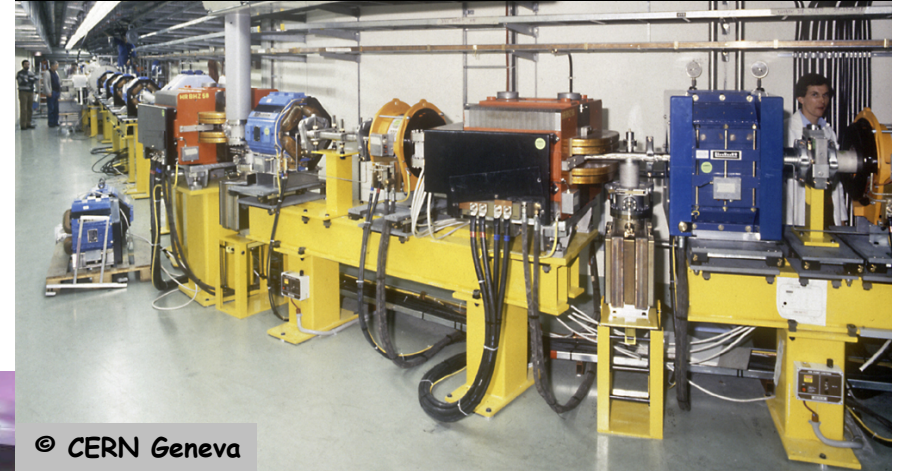

© CERN Geneva

Examples of different  
proton and electron  
synchrotrons at CERN

+ LHC (of course!)

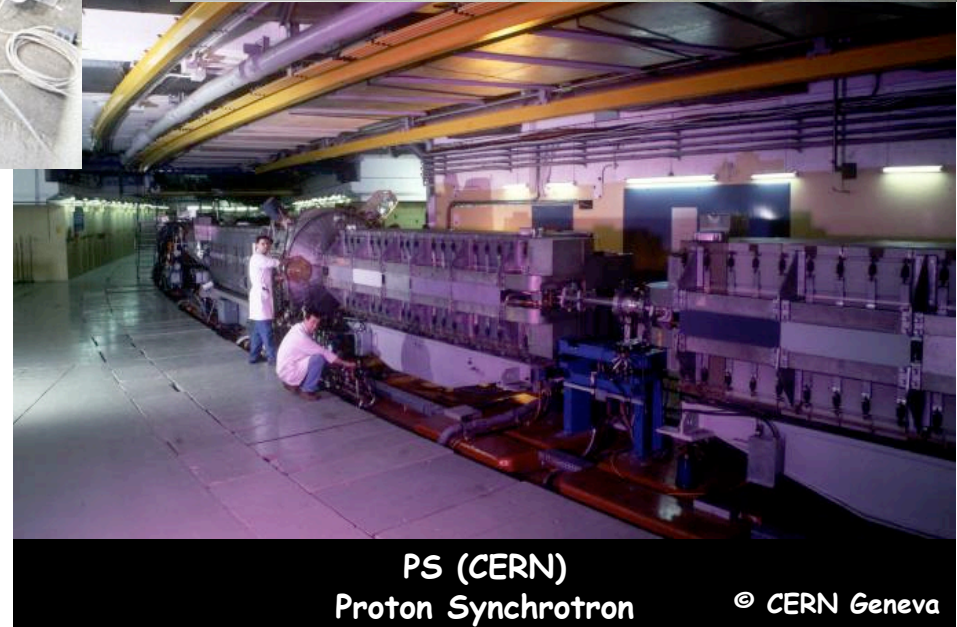

PS (CERN)  
Proton Synchrotron

© CERN Geneva

# The Synchrotron

The **synchrotron** is a synchronous accelerator since there is a **synchronous RF phase** for which the energy gain **fits** the **increase of the magnetic field** at each turn. That implies the following operating conditions:

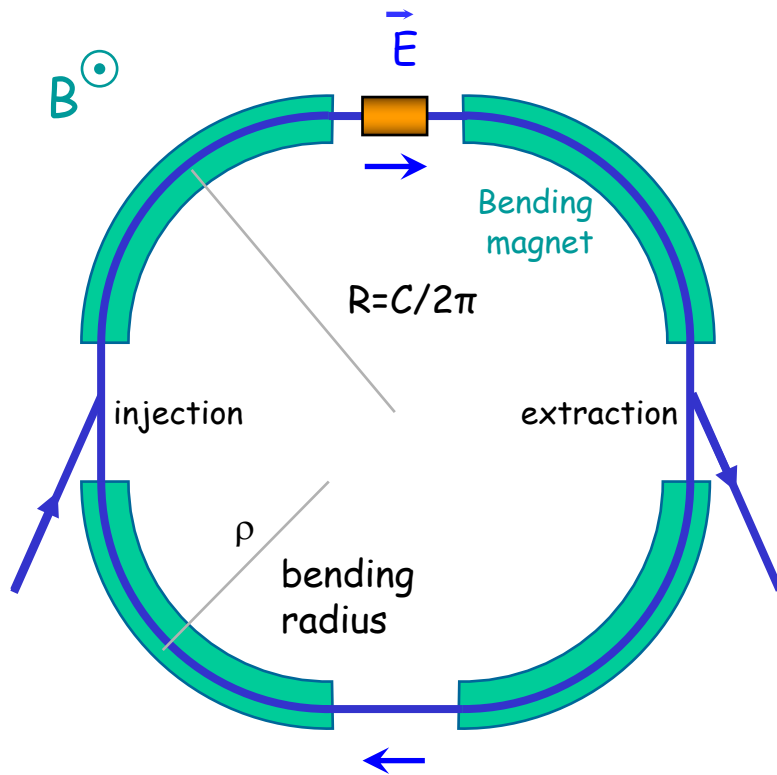

$$eV \sin \phi \longrightarrow \text{Energy gain per turn}$$

$$\phi = \phi_s = cte \longrightarrow \text{Synchronous particle}$$

$$\omega_{RF} = h\omega \longrightarrow \text{RF synchronism (h - harmonic number)}$$

$$\rho = cte \quad R = cte \longrightarrow \text{Constant orbit}$$

$$B\rho = P/e \Rightarrow B \longrightarrow \text{Variable magnetic field}$$

If  $v \approx c$ ,  $\omega$  hence  $\omega_{RF}$  remain constant (ultra-relativistic  $e^-$ )

# The Synchrotron - LHC Operation Cycle

The magnetic **field** (dipole current) is **increased during the acceleration**.

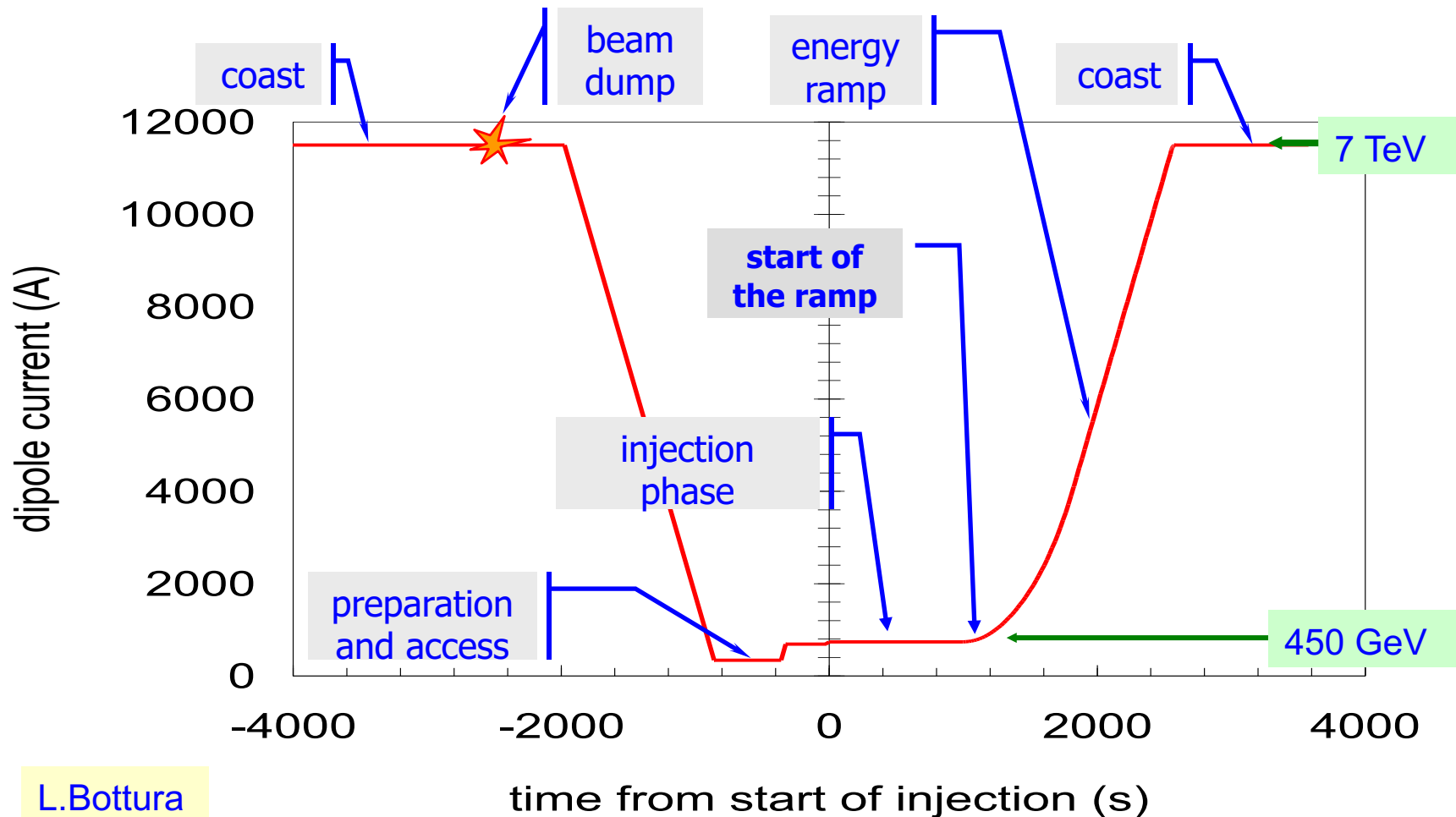

L.Bottura

# The Synchrotron - Energy ramping

Energy ramping by increasing the B field (frequency has to follow  $\nu$ ):

$$p = eB\rho \quad \Rightarrow \quad \frac{dp}{dt} = e\rho \dot{B} \quad \Rightarrow \quad (\Delta p)_{turn} = e\rho \dot{B} T_r = \frac{2\pi e\rho R \dot{B}}{\nu}$$

Since:  $E^2 = E_0^2 + p^2 c^2 \quad \Rightarrow \quad \Delta E = \nu \Delta p$

$$(\Delta E)_{turn} = (\Delta W)_s = 2\pi e\rho R \dot{B} = e\hat{V} \sin\phi_s$$

Stable phase  $\phi_s$  changes during energy ramping

$$\sin \phi_s = 2\pi \rho R \frac{\dot{B}}{\hat{V}_{RF}} \quad \Rightarrow \quad \phi_s = \arcsin\left(2\pi \rho R \frac{\dot{B}}{\hat{V}_{RF}}\right)$$

- The number of **stable synchronous particles** is equal to the **harmonic number h**. They are equally spaced along the circumference.
- Each synchronous particle satisfies the relation  $p=eB\rho$ . They have the nominal energy and follow the nominal trajectory.

# The Synchrotron - Frequency change

During the energy ramping, the RF frequency increases to follow the increase of the revolution frequency :

$$\omega = \frac{\omega_{RF}}{h} = \omega(B, R_s)$$

Hence: 
$$\frac{f_{RF}(t)}{h} = \frac{v(t)}{2\pi R_s} = \frac{1}{2\pi} \frac{ec^2}{E_s(t)} \frac{\rho}{R_s} B(t) \quad (\text{using } p(t) = eB(t)\rho, \quad E = mc^2)$$

Since  $E^2 = (m_0c^2)^2 + p^2c^2$  the RF frequency must follow the variation of the B field with the law

$$\frac{f_{RF}(t)}{h} = \frac{c}{2\pi R_s} \left\{ \frac{B(t)^2}{(m_0c^2 / ec\rho)^2 + B(t)^2} \right\}^{1/2}$$

This asymptotically tends towards  $f_r \rightarrow \frac{c}{2\pi R_s}$  when B becomes large compared to  $m_0c^2 / (ec\rho)$  which corresponds to  $v \rightarrow c$



# Dispersion Effects in a Synchrotron

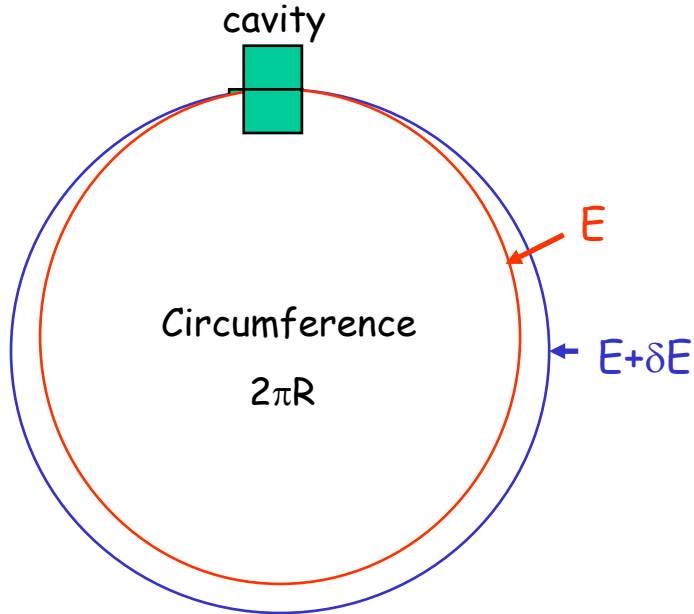

If a particle is slightly shifted in momentum it will have a different orbit and the orbit length is different.

The "momentum compaction factor" is defined as:

$$\alpha_c = \frac{dL/L}{dp/p}$$

$$\alpha_c = \frac{p}{L} \frac{dL}{dp}$$

If the particle is shifted in momentum it will have also a different velocity. As a result of both effects the revolution frequency changes with a "slip factor":

$$\eta = \frac{df_r/f_r}{dp/p} \Rightarrow$$

$$\eta = \frac{p}{f_r} \frac{df_r}{dp}$$

**p=particle momentum**

**R=synchrotron physical radius**

**f<sub>r</sub>=revolution frequency**

# Momentum Compaction Factor

$$\alpha_c = \frac{p \, dL}{L \, dp}$$

$$ds_0 = \rho d\theta$$

$$ds = (\rho + x) d\theta$$

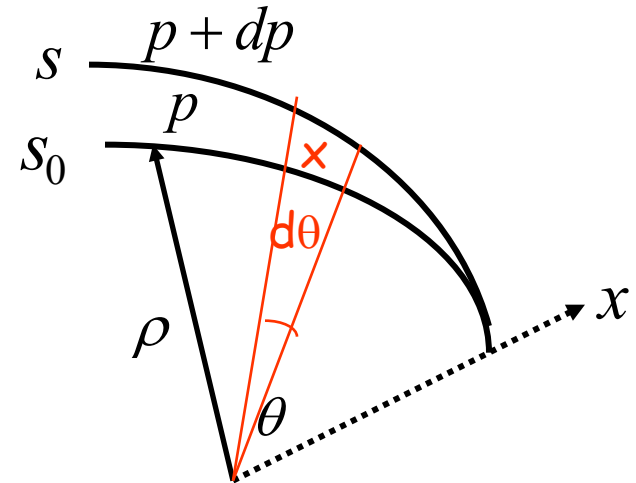

The elementary path difference

from the two orbits is:

definition of dispersion  $D_x$

$$\frac{dl}{ds_0} = \frac{ds - ds_0}{ds_0} = \frac{x}{\rho} \stackrel{\text{definition of } D_x}{=} \frac{D_x}{\rho} \frac{dp}{p}$$

leading to the total change in the circumference:

$$dL = \int_C dl = \int_C \frac{x}{\rho} ds_0 = \int_C \frac{D_x}{\rho} \frac{dp}{p} ds_0$$

$$\alpha_c = \frac{1}{L} \int_C \frac{D_x(s)}{\rho(s)} ds_0$$

With  $\rho = \infty$  in straight sections we get:

$$\alpha_c = \frac{\langle D_x \rangle_m}{R}$$

$\langle \rangle_m$  means that the average is considered over the bending magnet only



# Dispersion Effects - Revolution Frequency

There are **two effects** changing the revolution frequency:  
the **orbit length** and the **velocity** of the particle

$$f_r = \frac{\beta c}{2\pi R} \quad \Rightarrow \quad \frac{df_r}{f_r} = \frac{d\beta}{\beta} - \frac{dR}{R} \stackrel{\uparrow}{=} \frac{d\beta}{\beta} - \alpha_c \frac{dp}{p}$$

definition of momentum  
compaction factor

$$p = mv = \beta\gamma \frac{E_0}{c} \quad \Rightarrow \quad \frac{dp}{p} = \frac{d\beta}{\beta} + \frac{d(1-\beta^2)^{-1/2}}{(1-\beta^2)^{-1/2}} = \underbrace{(1-\beta^2)^{-1}}_{\gamma^2} \frac{d\beta}{\beta}$$

$$\frac{df_r}{f_r} = \left( \frac{1}{\gamma^2} - \alpha_c \right) \frac{dp}{p} \quad \xrightarrow{\frac{df_r}{f_r} = \eta \frac{dp}{p}} \quad \eta = \frac{1}{\gamma^2} - \alpha_c$$

$\eta=0$  at the **transition energy**

$$\gamma_t = \frac{1}{\sqrt{\alpha_c}}$$

# Phase Stability in a Synchrotron

From the definition of  $\eta$  it is clear that an **increase in momentum** gives  
 - **below transition** ( $\eta > 0$ ) a **higher revolution frequency**  
 (increase in velocity dominates) while

- **above transition** ( $\eta < 0$ ) a **lower revolution frequency** ( $v \approx c$  and longer path)  
 where the momentum compaction (generally  $> 0$ ) dominates.

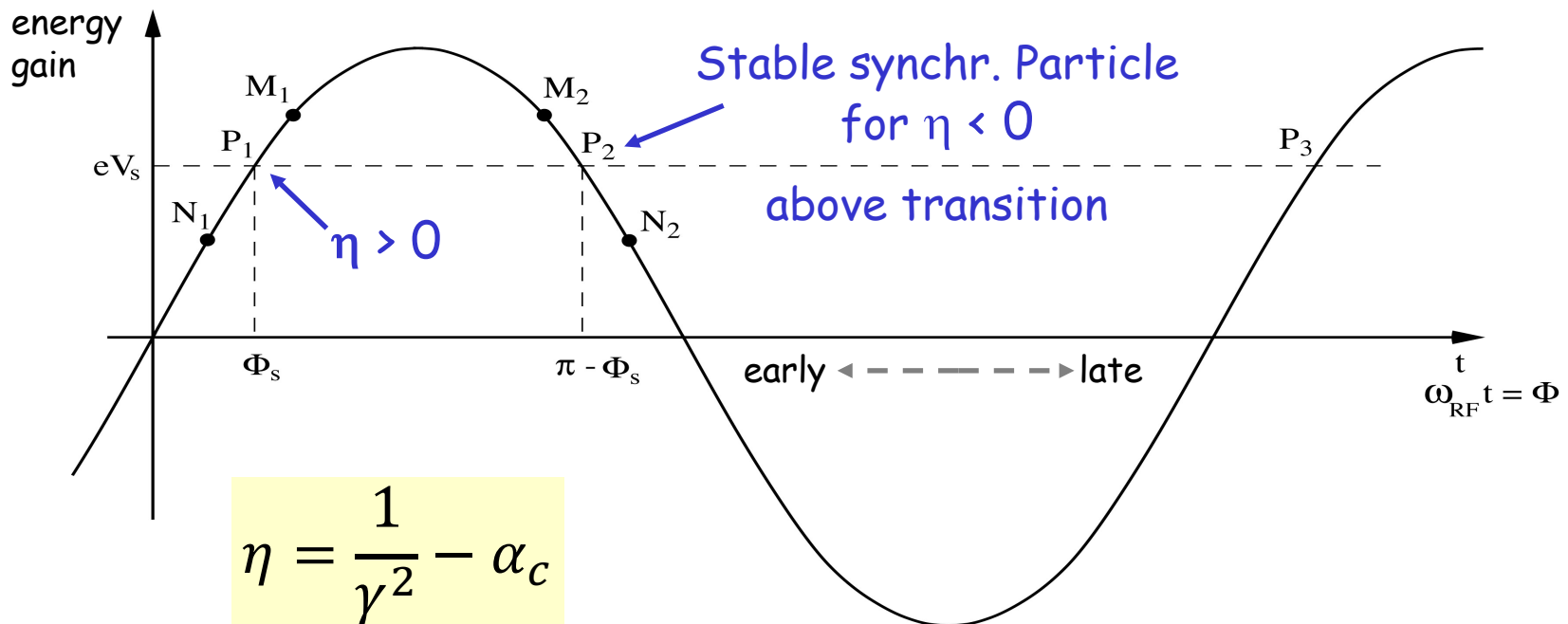

# Crossing Transition

At **transition**, the velocity change and the path length change with momentum compensate each other. So the revolution frequency there is independent from the momentum deviation.

Crossing transition during acceleration makes the previous stable synchronous phase unstable. The RF system needs to make a rapid change of the RF phase, a '**phase jump**'.

$$\alpha_c \sim \frac{1}{Q_x^2}$$

$$\gamma_t = \frac{1}{\sqrt{\alpha_c}} \sim Q_x$$

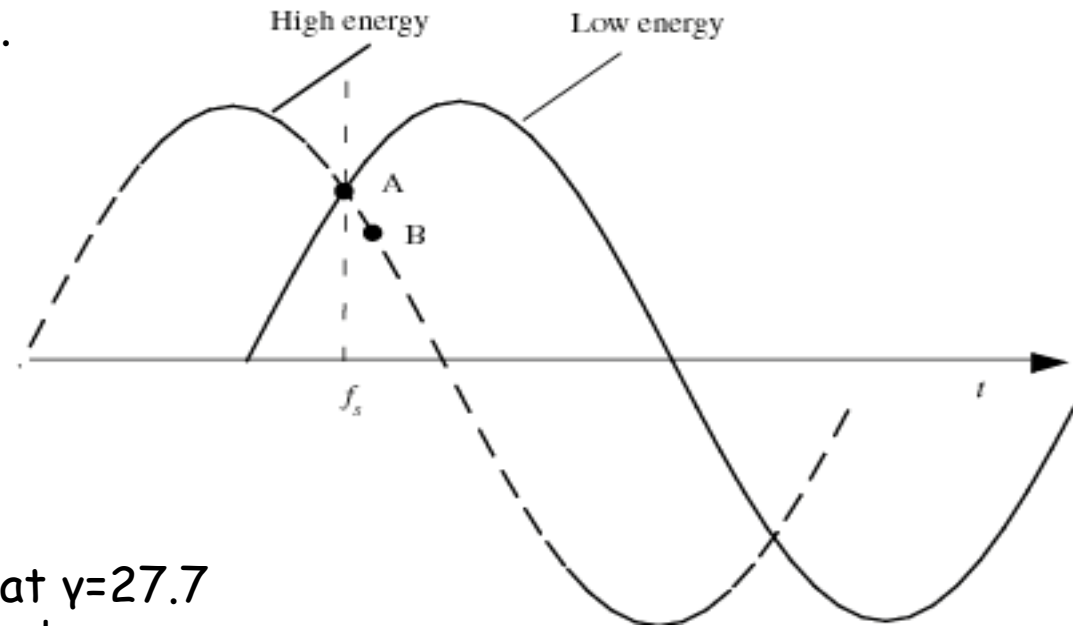

In the PS:  $\gamma_t$  is at  $\sim 6$  GeV

In the SPS:  $\gamma_t = 22.8$ , injection at  $\gamma = 27.7$   
 $\Rightarrow$  no transition crossing!

In the LHC:  $\gamma_t$  is at  $\sim 55$  GeV, also far below injection energy

Transition crossing not needed in leptons machines, why?

# Dynamics: Synchrotron oscillations

Simple case (no accel.):  $B = \text{const.}$ , below transition  $\gamma < \gamma_t$

The phase of the synchronous particle must therefore be  $\phi_0 = 0$ .

- $\Phi_1$
- The particle **B** is accelerated
  - Below transition, an energy increase means an increase in revolution frequency
  - The particle arrives earlier - tends toward  $\phi_0$

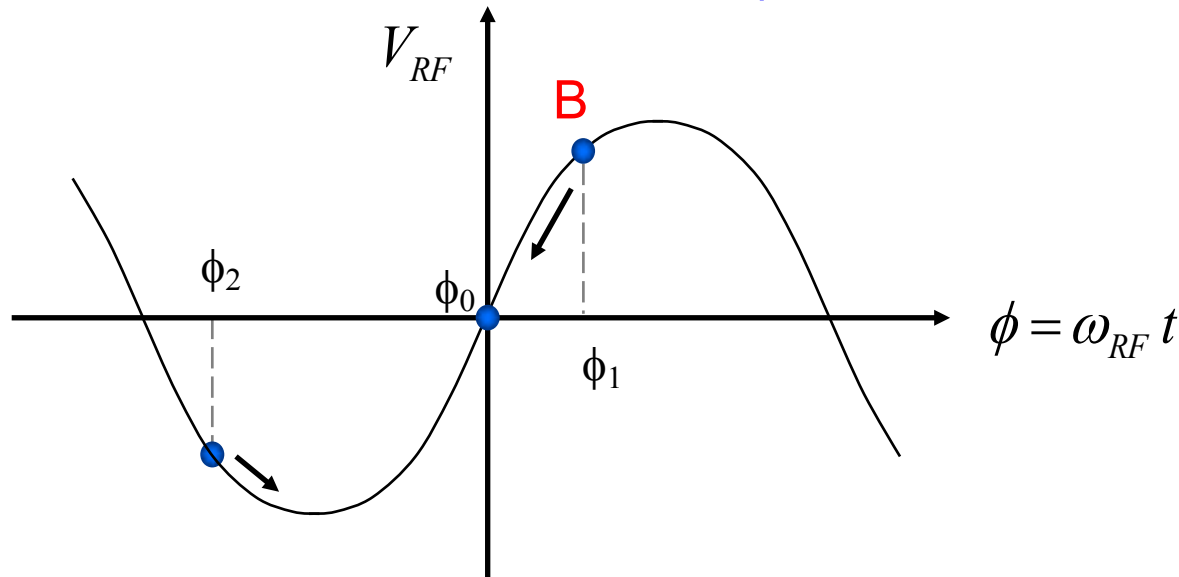

- $\phi_2$
- The particle is decelerated
  - decrease in energy - decrease in revolution frequency
  - The particle arrives later - tends toward  $\phi_0$

# Synchrotron oscillations

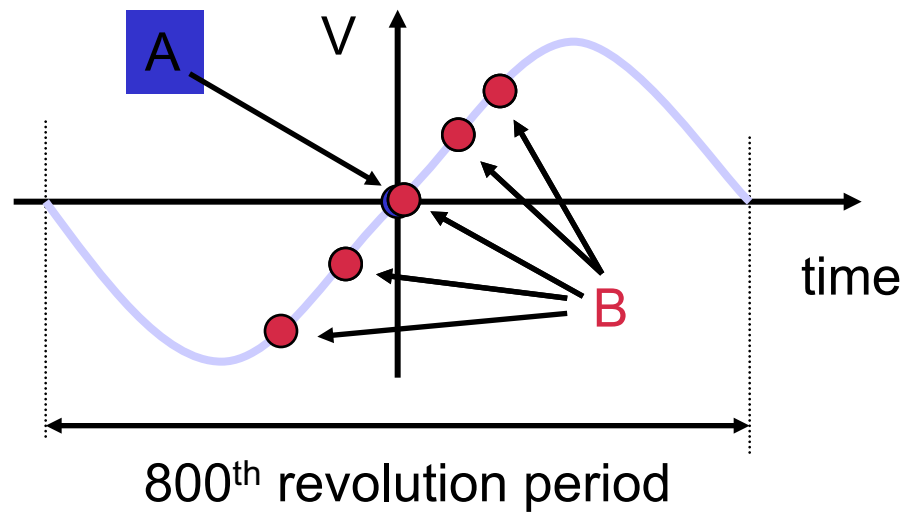

# Synchrotron oscillations

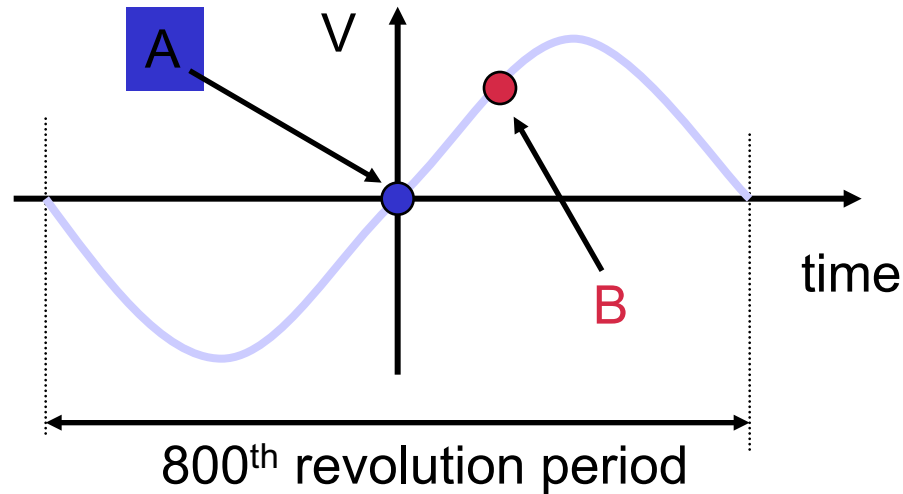

Particle **B** has made one full oscillation around particle **A**.

The amplitude depends on the initial phase and energy.

Exactly like the pendulum

This oscillation is called:

**Synchrotron Oscillation**

# The Potential Well

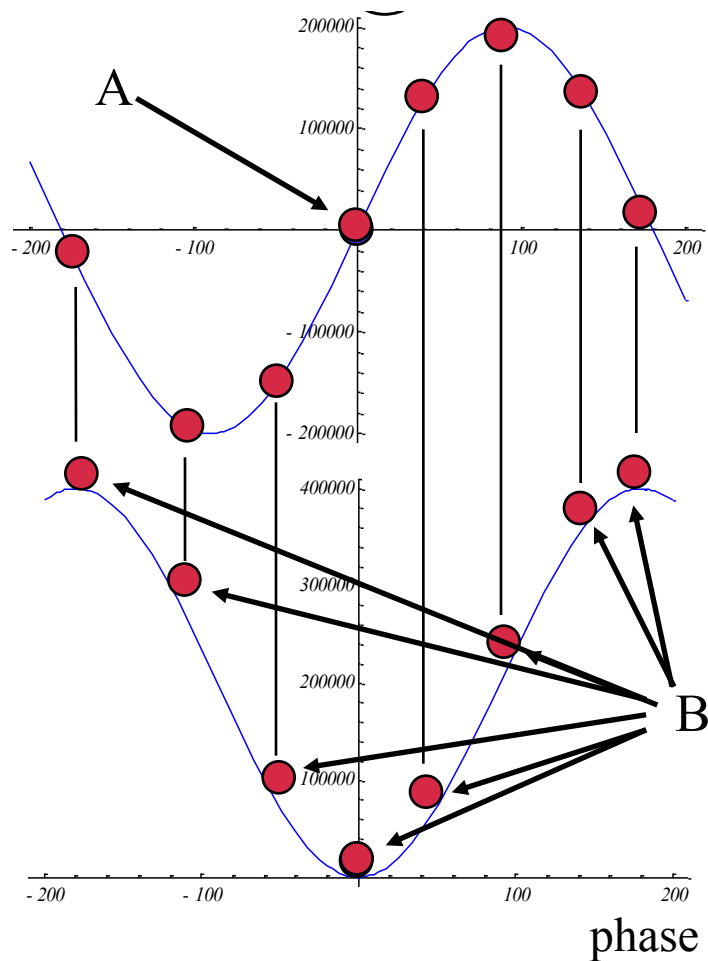

Cavity voltage

Potential well

# Longitudinal Phase Space Motion

Particle **B** oscillates around particle **A**

This is a synchrotron oscillation

Plotting this motion in longitudinal phase space gives:

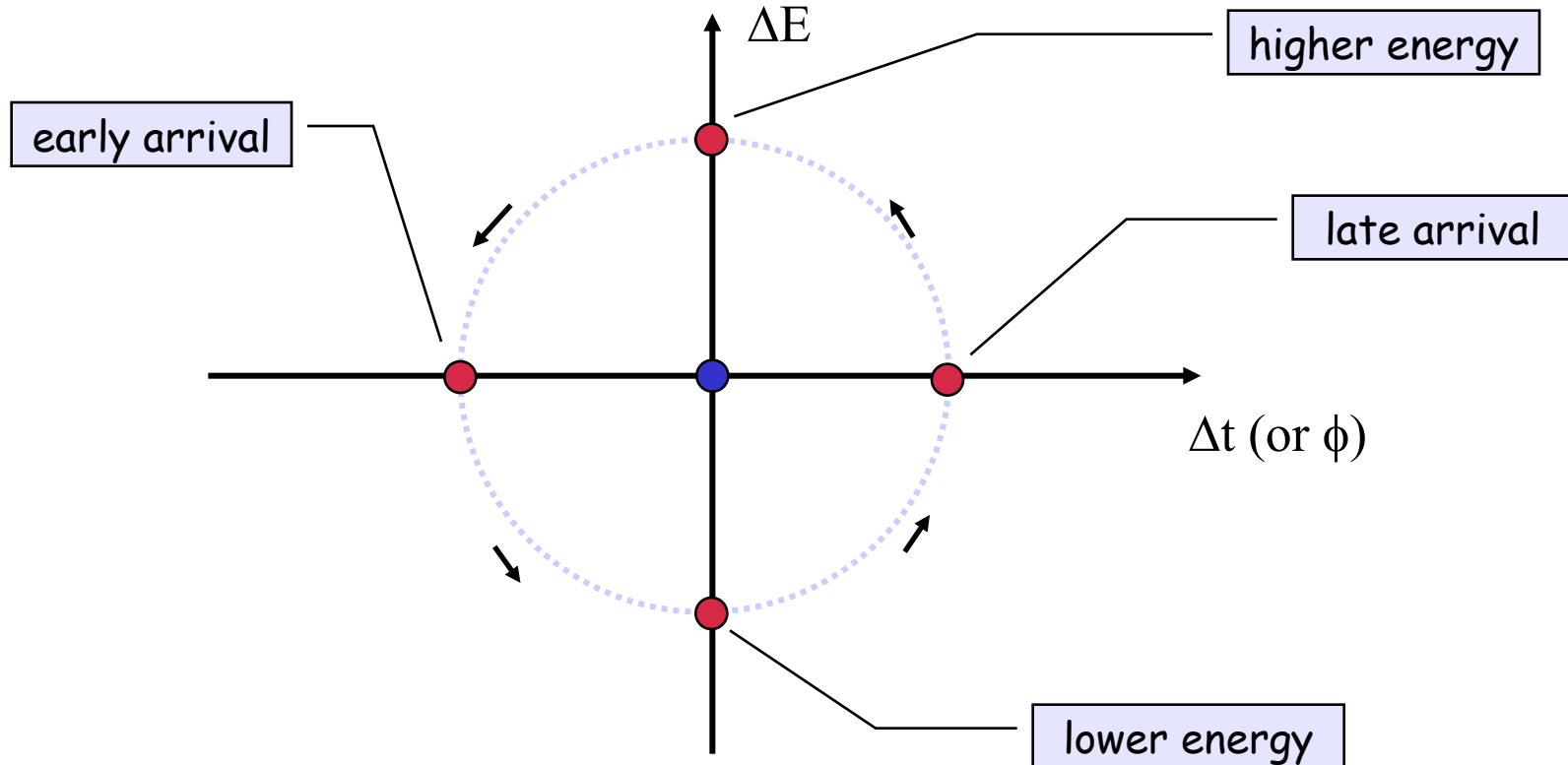



# Synchrotron oscillations - No acceleration

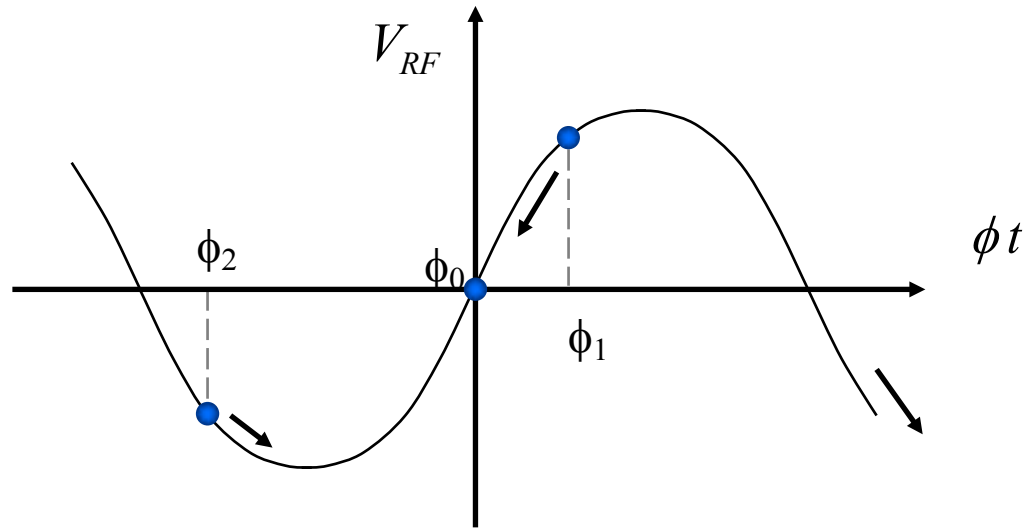

Phase space picture

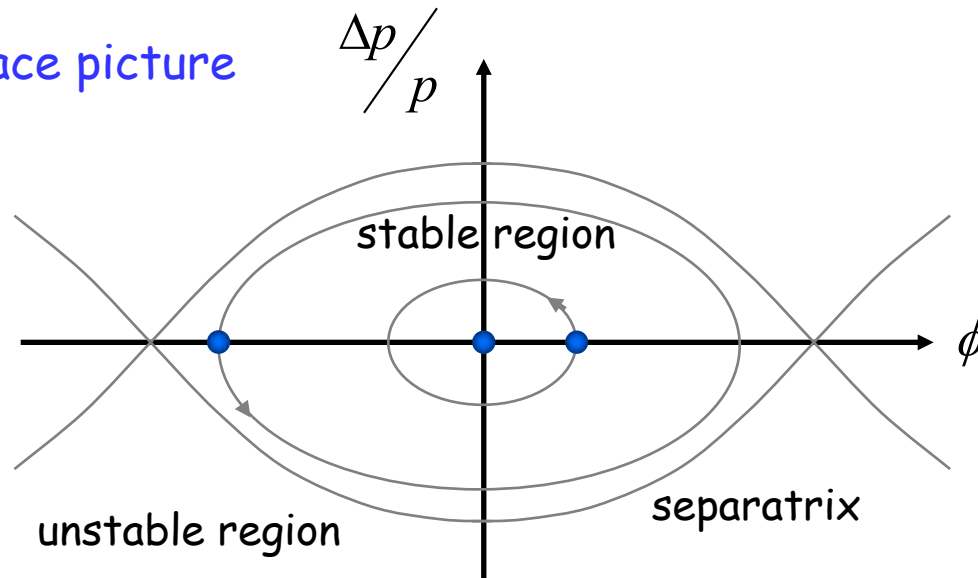

# Synchrotron oscillations (with acceleration)

Case with acceleration  $B$  increasing

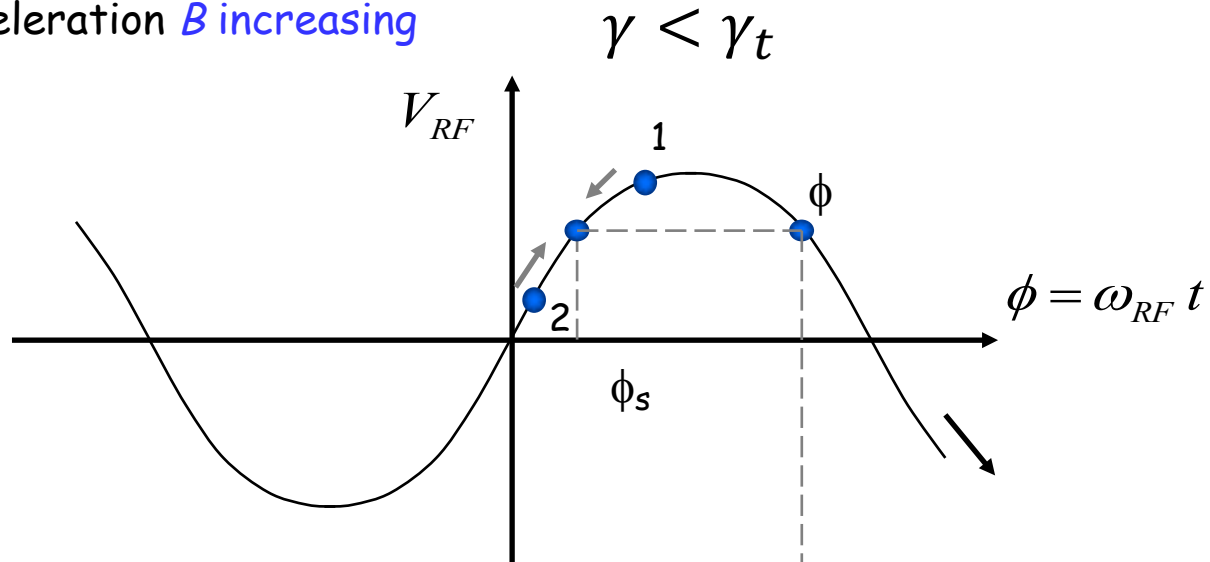

Phase space picture

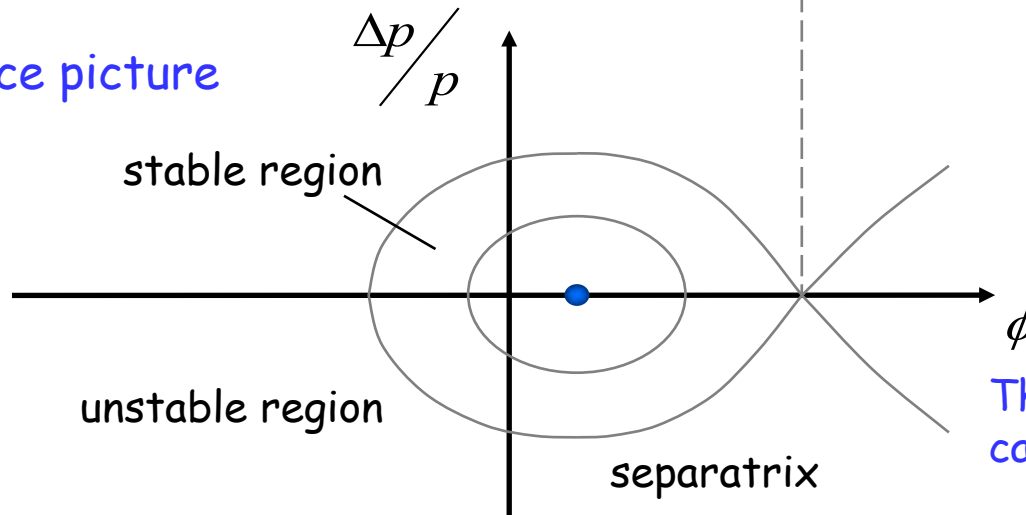

$$\phi_s < \phi < \pi - \phi_s$$

The symmetry of the case  $B = \text{const.}$  is lost

# Synchrotron motion in phase space

$\Delta E$ - $\phi$  phase space of a **stationary bucket**  
(when there is **no acceleration**)

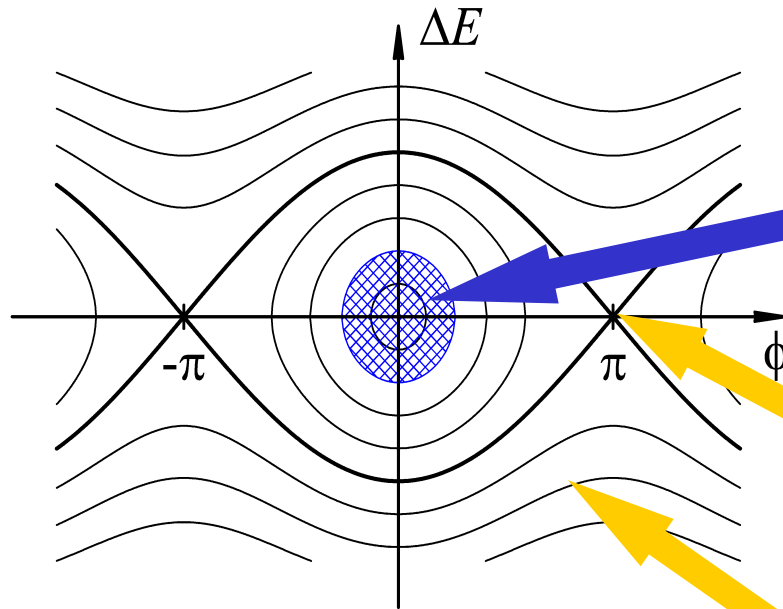

**Bucket area:** area enclosed by the separatrix  
The area covered by particles is the longitudinal emittance

**Dynamics of a particle**  
Non-linear, conservative oscillator → e.g. pendulum

Particle inside the separatrix:

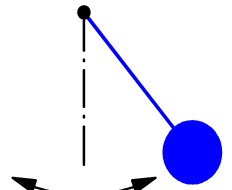

Particle at the unstable fix-point



Particle outside the separatrix:

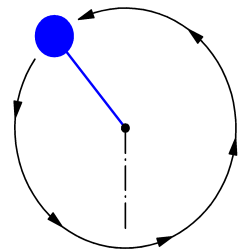

# (Stationary) Bunch & Bucket

The **bunches** of the beam **fill** usually **a part of** the **bucket** area.

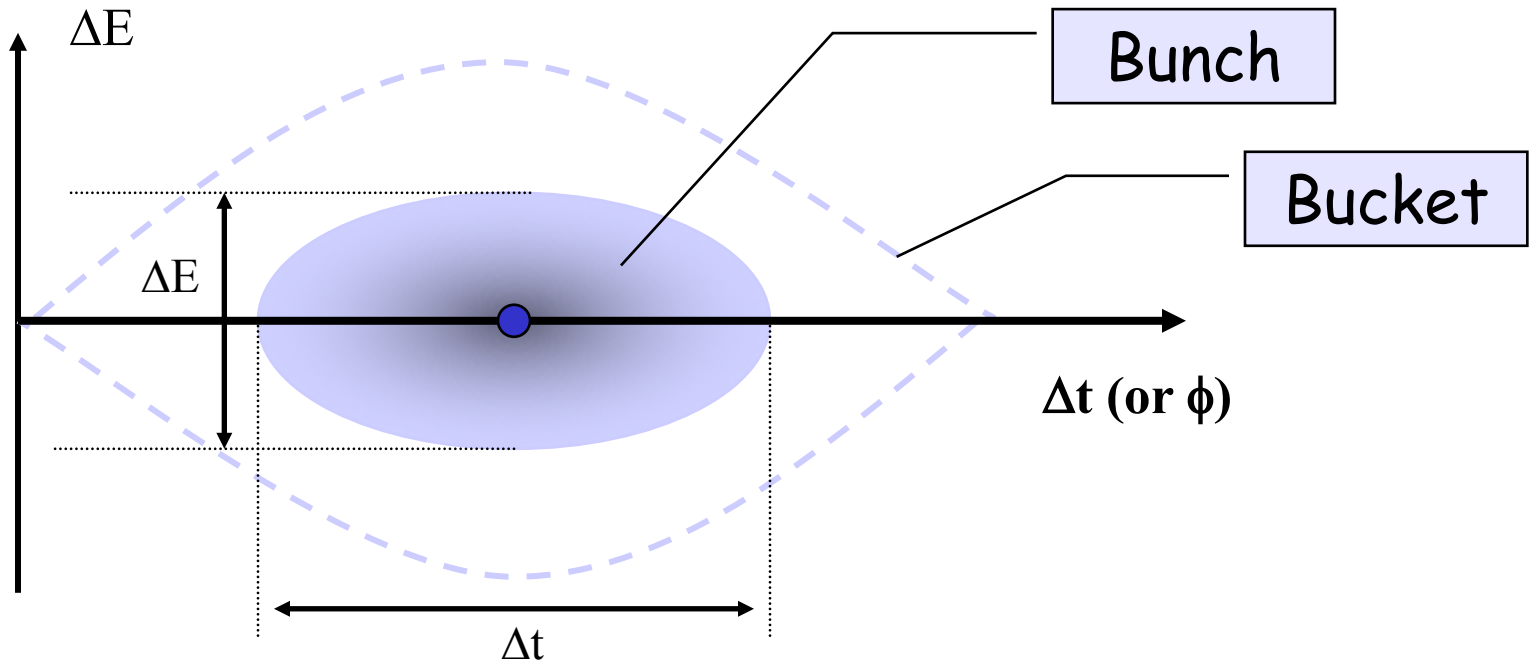

Bucket area = longitudinal Acceptance [eVs]

Bunch area = longitudinal beam emittance =  $4\pi \sigma_E \sigma_t$  [eVs]

**Attention: Different definitions are used!**

# Synchrotron motion in phase space

The restoring force is **non-linear**.

⇒ speed of motion depends on position in phase-space

(here shown for a stationary bucket)

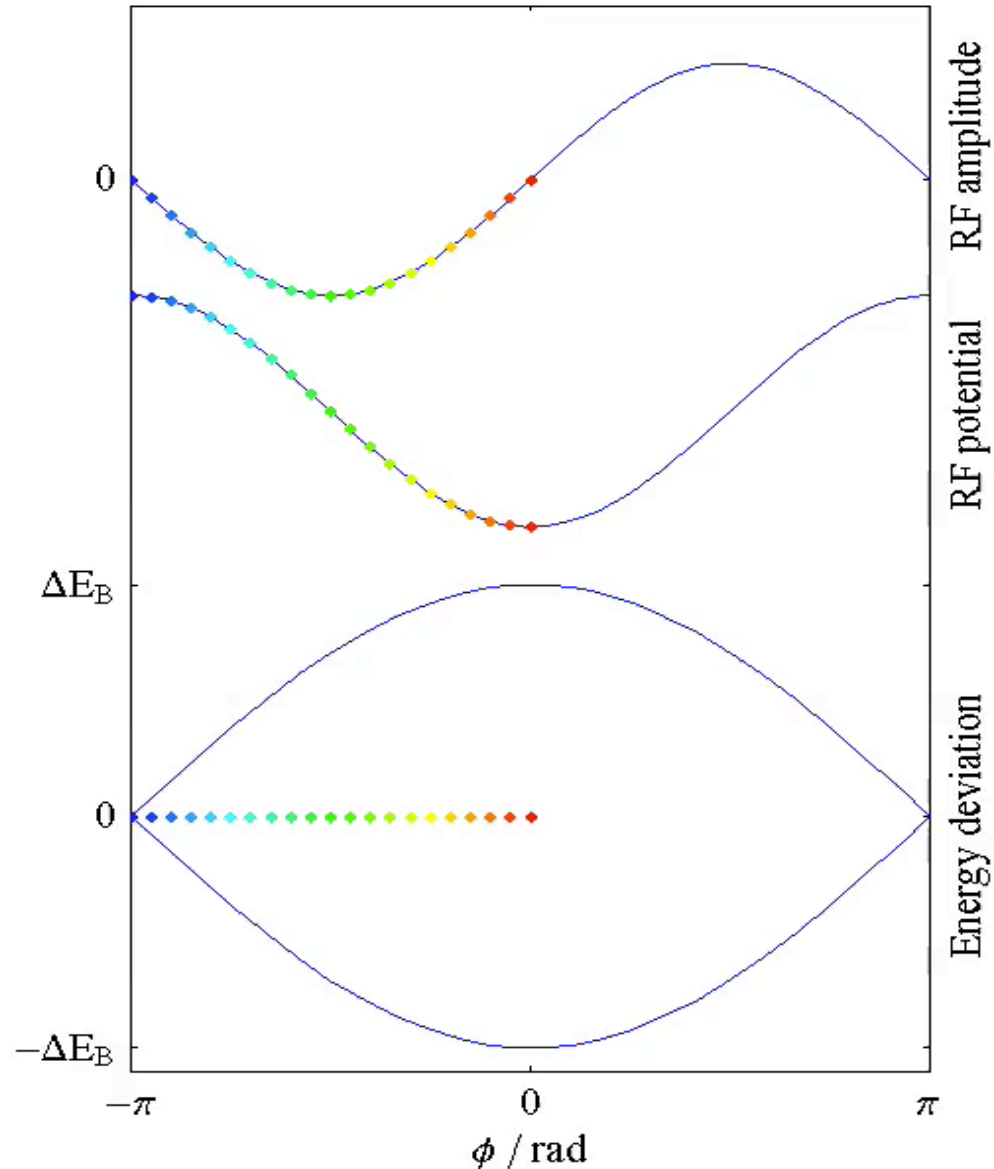

# RF Acceptance versus Synchronous Phase

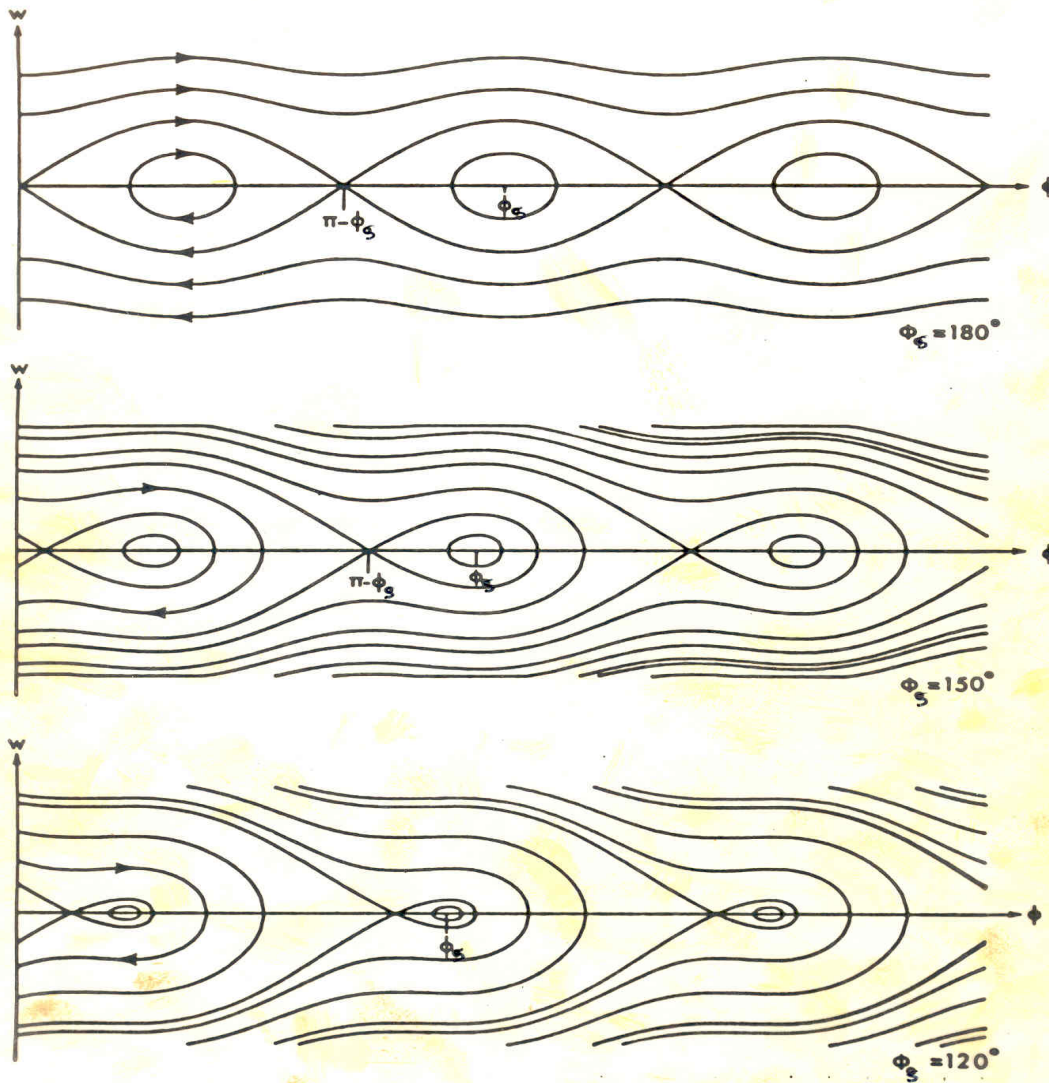

The areas of stable motion (closed trajectories) are called "BUCKET".

As the synchronous phase gets closer to  $90^\circ$  the buckets get smaller.

The number of circulating buckets is equal to "h".

The phase extension of the bucket is maximum for  $\phi_s = 180^\circ$  (or  $0^\circ$ ) which correspond to no acceleration. The RF acceptance increases with the RF voltage.

# Longitudinal Dynamics in Synchrotrons

It is also often called “**synchrotron motion**”.

The RF acceleration process clearly emphasizes two coupled variables, the **energy** gained by the particle and the **RF phase** experienced by the same particle. Since there is a well defined synchronous particle which has always the same phase  $\phi_s$ , and the nominal energy  $E_s$ , it is sufficient to follow other particles with respect to that particle.

So let's introduce the following reduced variables:

revolution frequency :  $\Delta f_r = f_r - f_{rs}$

particle RF phase :  $\Delta\phi = \phi - \phi_s$

particle momentum :  $\Delta p = p - p_s$

particle energy :  $\Delta E = E - E_s$

azimuth angle :  $\Delta\theta = \theta - \theta_s$

# First Energy-Phase Equation

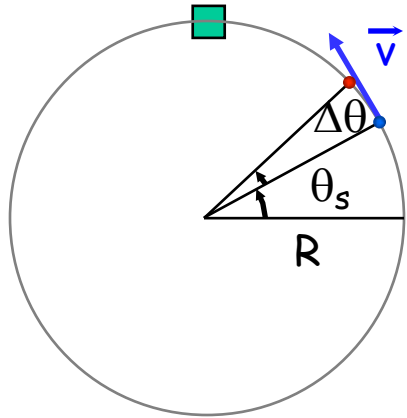

$$f_{RF} = h f_r \Rightarrow \Delta\phi = -h \Delta\theta \quad \text{with} \quad \theta = \int \omega dt$$

particle ahead arrives earlier  
 $\Rightarrow$  smaller RF phase

For a given particle with respect to the reference one:

$$\Delta\omega = \frac{d}{dt} (\Delta\theta) = -\frac{1}{h} \frac{d}{dt} (\Delta\phi) = -\frac{1}{h} \frac{d\phi}{dt}$$

Since:  $\eta = \frac{p_s}{\omega_{rs}} \left( \frac{d\omega}{dp} \right)_s$  and

$$E^2 = E_0^2 + p^2 c^2$$

$$\Delta E = v_s \Delta p = \omega_{rs} R_s \Delta p$$

one gets:

$$\frac{\Delta E}{\omega_{rs}} = -\frac{p_s R_s}{h \eta \omega_{rs}} \frac{d(\Delta\phi)}{dt} = -\frac{p_s R_s}{h \eta \omega_{rs}} \dot{\phi}$$



## Second Energy-Phase Equation

The rate of energy gained by a particle is:  $\frac{dE}{dt} = e\hat{V} \sin\phi \frac{\omega_r}{2\pi}$

The rate of relative energy gain with respect to the reference particle is then:

$$2\pi \Delta \left( \frac{\dot{E}}{\omega_r} \right) = e\hat{V} (\sin\phi - \sin\phi_s)$$

Expanding the left-hand side to first order:

$$\Delta(\dot{E}T_r) \cong \dot{E}\Delta T_r + T_{rs}\Delta\dot{E} = \Delta E\dot{T}_r + T_{rs}\Delta\dot{E} = \frac{d}{dt}(T_{rs}\Delta E)$$

leads to the second energy-phase equation:

$$2\pi \frac{d}{dt} \left( \frac{\Delta E}{\omega_{rs}} \right) = e\hat{V} (\sin\phi - \sin\phi_s)$$

## Equations of Longitudinal Motion

$$\frac{\Delta E}{\omega_{rs}} = -\frac{p_s R_s}{h \eta \omega_{rs}} \frac{d(\Delta \phi)}{dt} = -\frac{p_s R_s}{h \eta \omega_{rs}} \dot{\phi}$$

$$2\pi \frac{d}{dt} \left( \frac{\Delta E}{\omega_{rs}} \right) = e \hat{V} (\sin \phi - \sin \phi_s)$$

deriving and combining

$$\frac{d}{dt} \left[ \frac{R_s p_s}{h \eta \omega_{rs}} \frac{d\phi}{dt} \right] + \frac{e \hat{V}}{2\pi} (\sin \phi - \sin \phi_s) = 0$$

This second order equation is non linear. Moreover the parameters within the bracket are in general slowly varying with time.

We will study some cases in the following...

# Small Amplitude Oscillations

Let's assume constant parameters  $R_s$ ,  $p_s$ ,  $\omega_s$  and  $\eta$ :

$$\ddot{\phi} + \frac{\Omega_s^2}{\cos\phi_s} (\sin\phi - \sin\phi_s) = 0$$

with

$$\Omega_s^2 = \frac{h\eta\omega_{rs}e\hat{V}\cos\phi_s}{2\pi R_s p_s}$$

Consider now **small** phase **deviations** from the reference particle:

$$\sin\phi - \sin\phi_s = \sin(\phi_s + \Delta\phi) - \sin\phi_s \cong \cos\phi_s \Delta\phi \quad (\text{for small } \Delta\phi)$$

and the corresponding linearized motion reduces to a **harmonic oscillation**:

$$\ddot{\phi} + \Omega_s^2 \Delta\phi = 0$$

where  $\Omega_s$  is the synchrotron angular frequency

# Stability condition for $\phi_s$

Stability is obtained when  $\Omega_s$  is real and so  $\Omega_s^2$  positive:

$$\Omega_s^2 = \frac{e \hat{V}_{RF} \eta h \omega_s}{2\pi R_s p_s} \cos \phi_s \Rightarrow \Omega_s^2 > 0 \Leftrightarrow \eta \cos \phi_s > 0$$

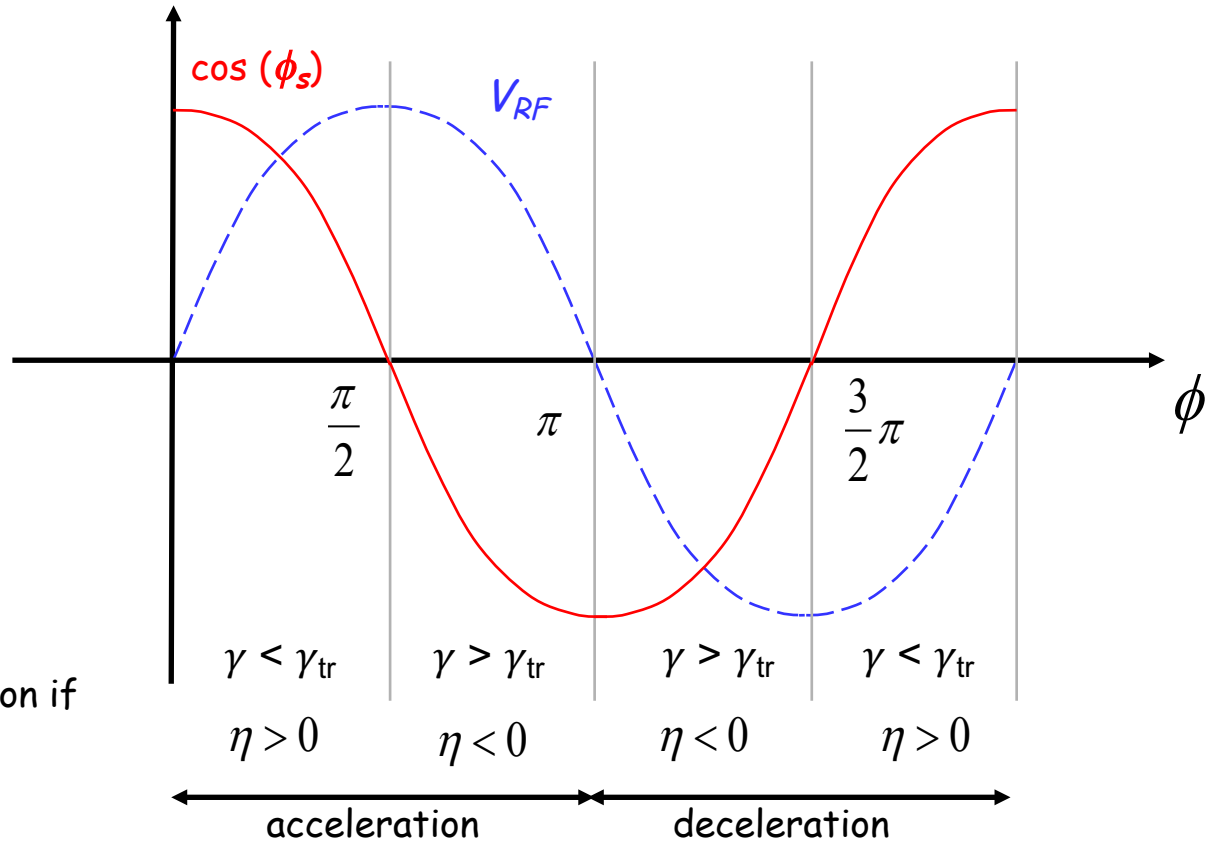

Stable in the region if

# Large Amplitude Oscillations

For larger phase (or energy) deviations from the reference the second order differential equation is non-linear:

$$\ddot{\phi} + \frac{\Omega_s^2}{\cos \phi_s} (\sin \phi - \sin \phi_s) = 0 \quad (\Omega_s \text{ as previously defined})$$

Multiplying by  $\dot{\phi}$  and integrating gives an invariant of the motion:

$$\frac{\dot{\phi}^2}{2} - \frac{\Omega_s^2}{\cos \phi_s} (\cos \phi + \phi \sin \phi_s) = I$$

which for small amplitudes reduces to:

$$\frac{\dot{\phi}^2}{2} + \Omega_s^2 \frac{(\Delta\phi)^2}{2} = I' \quad (\text{the variable is } \Delta\phi, \text{ and } \phi_s \text{ is constant})$$

Similar equations exist for the second variable :  $\Delta E \propto d\phi/dt$

## Large Amplitude Oscillations (2)

When  $\phi$  reaches  $\pi - \phi_s$  the force goes to zero and beyond it becomes non restoring.

Hence  $\pi - \phi_s$  is an extreme amplitude for a stable motion which in the phase space  $(\frac{\dot{\phi}}{\Omega_s}, \Delta\phi)$  is shown as closed trajectories.

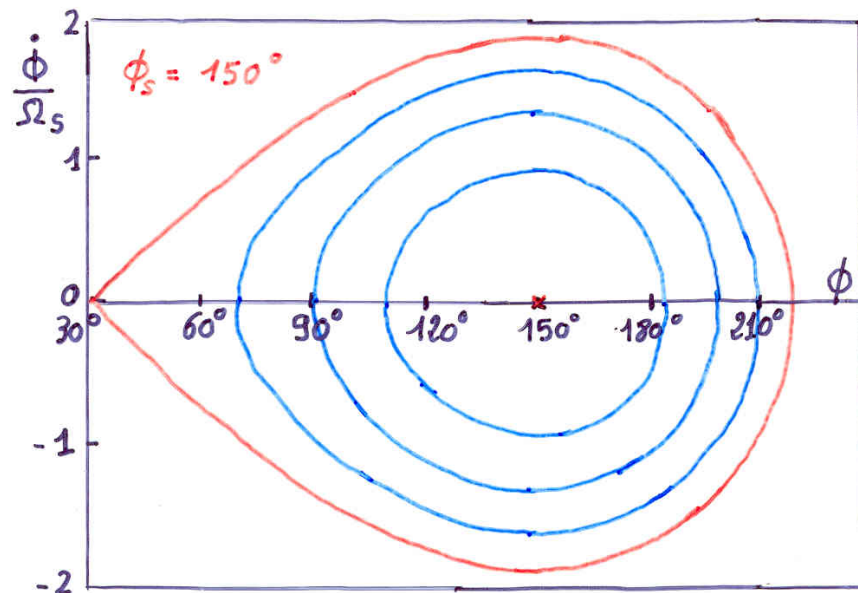

Equation of the **separatrix**:

$$\frac{\dot{\phi}^2}{2} - \frac{\Omega_s^2}{\cos \phi_s} (\cos \phi + \phi \sin \phi_s) = -\frac{\Omega_s^2}{\cos \phi_s} (\cos(\pi - \phi_s) + (\pi - \phi_s) \sin \phi_s)$$

Second value  $\phi_m$  where the separatrix crosses the horizontal axis:

$$\cos \phi_m + \phi_m \sin \phi_s = \cos(\pi - \phi_s) + (\pi - \phi_s) \sin \phi_s$$

## Energy Acceptance

From the equation of motion it is seen that  $\dot{\phi}$  reaches an extreme when  $\ddot{\phi} = 0$ , hence corresponding to  $\phi = \phi_s$ .

Introducing this value into the equation of the separatrix gives:

$$\dot{\phi}_{\max}^2 = 2\Omega_s^2 \left\{ 2 + (2\phi_s - \pi) \tan \phi_s \right\}$$

That translates into an **acceptance in energy**:

$$\left( \frac{\Delta E}{E_s} \right)_{\max} = \mp \beta \sqrt{-\frac{e\hat{V}}{\pi h \eta E_s} G(\phi_s)}$$

$$G(\phi_s) = [2 \cos \phi_s + (2\phi_s - \pi) \sin \phi_s]$$

This “**RF acceptance**” depends strongly on  $\phi_s$  and plays an important role for the capture at injection, and the stored beam lifetime.

It's **largest** for  $\phi_s=0$  and  $\phi_s=\pi$  (**no acceleration**, depending on  $\eta$ ).

Need a **higher RF voltage** for **higher acceptance**.

# RF Acceptance versus Synchronous Phase

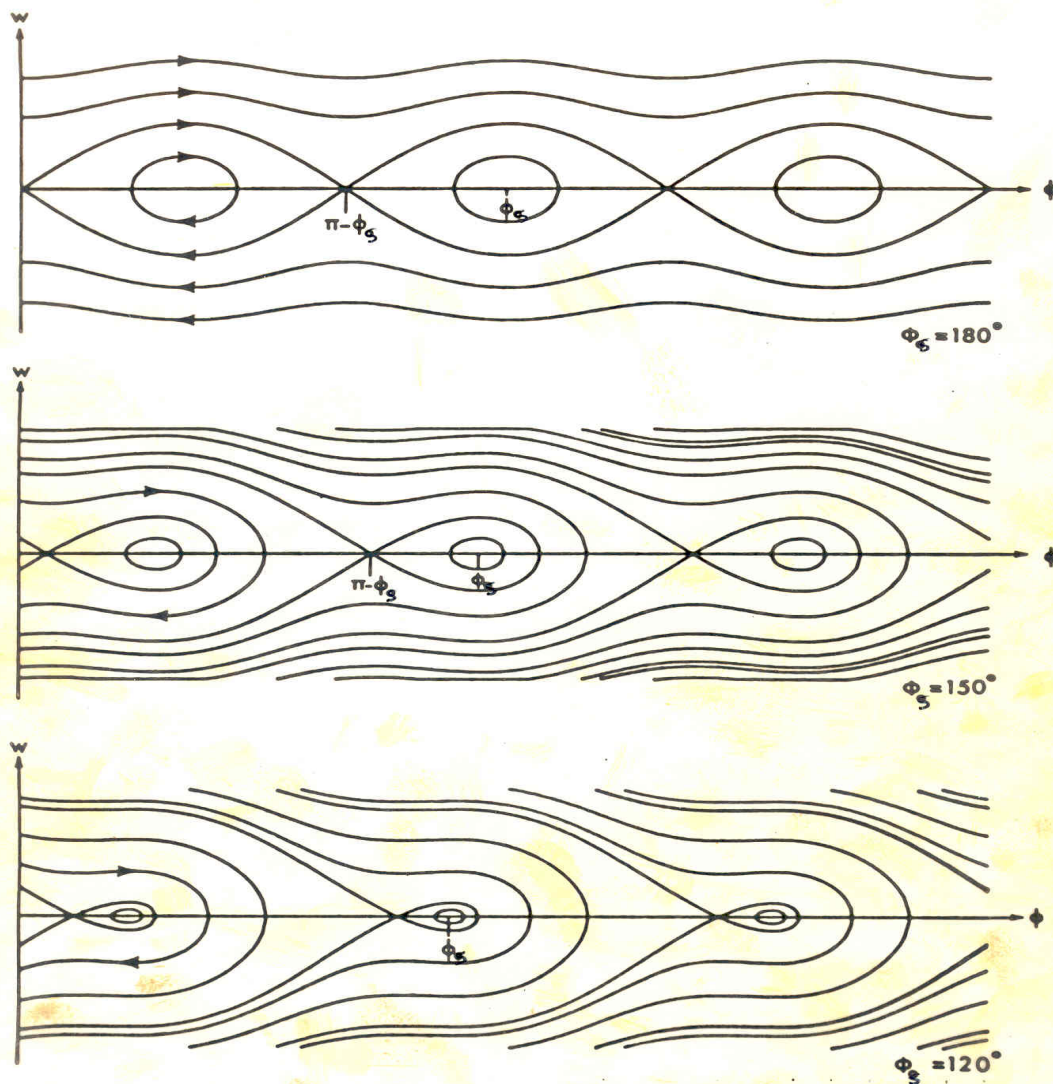

The areas of stable motion (closed trajectories) are called "BUCKET".

As the synchronous phase gets closer to  $90^\circ$  the buckets get smaller.

The number of circulating buckets is equal to "h".

The phase extension of the bucket is maximum for  $\phi_s = 180^\circ$  (or  $0^\circ$ ) which correspond to no acceleration. The RF acceptance increases with the RF voltage.



# Effect of a Mismatch

Injected bunch: short length and large energy spread  
 after 1/4 synchrotron period: longer bunch with a smaller energy spread.

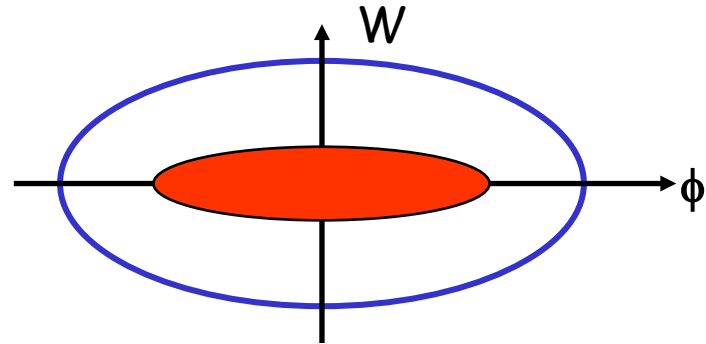
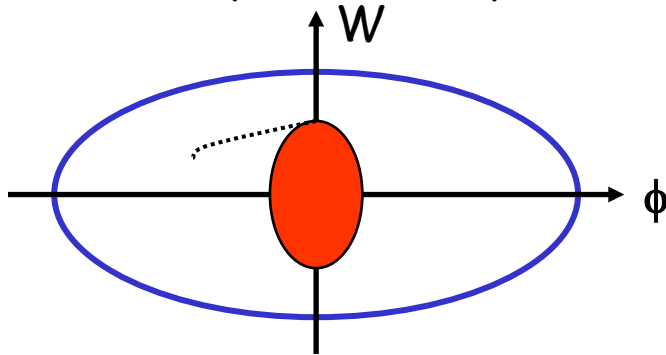

For **larger amplitudes**, the angular phase space motion is slower  
 (1/8 period shown below) => can lead to **filamentation** and **emittance growth**

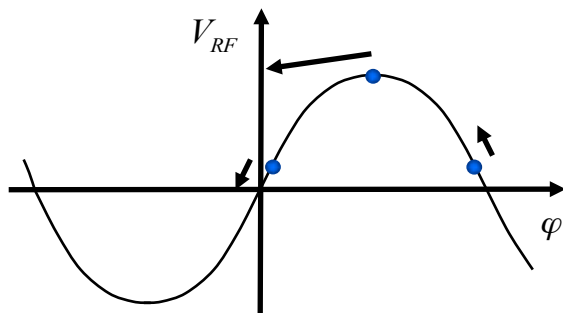

restoring force is non-linear

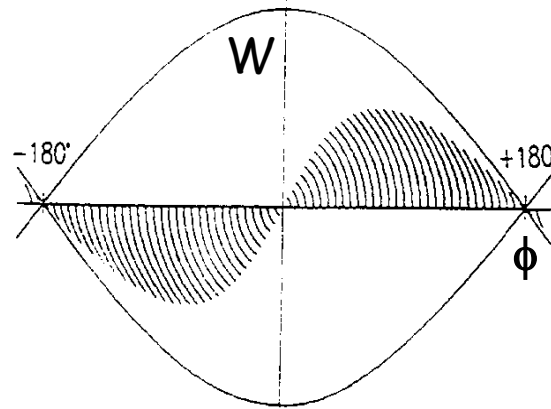

stationary bucket

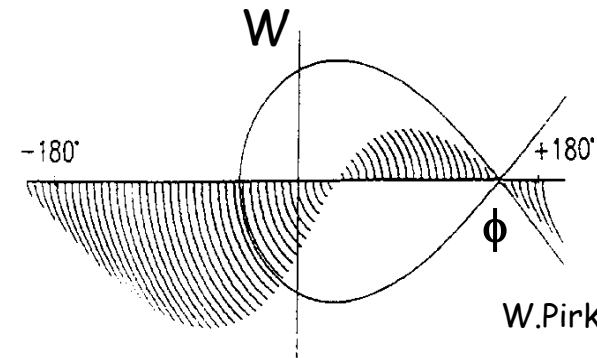

accelerating bucket

W.Pirkel

## Effect of a Mismatch (2)

Evolution of an injected beam for the first 100 turns.

For a matched transfer, the emittance does not grow (left).

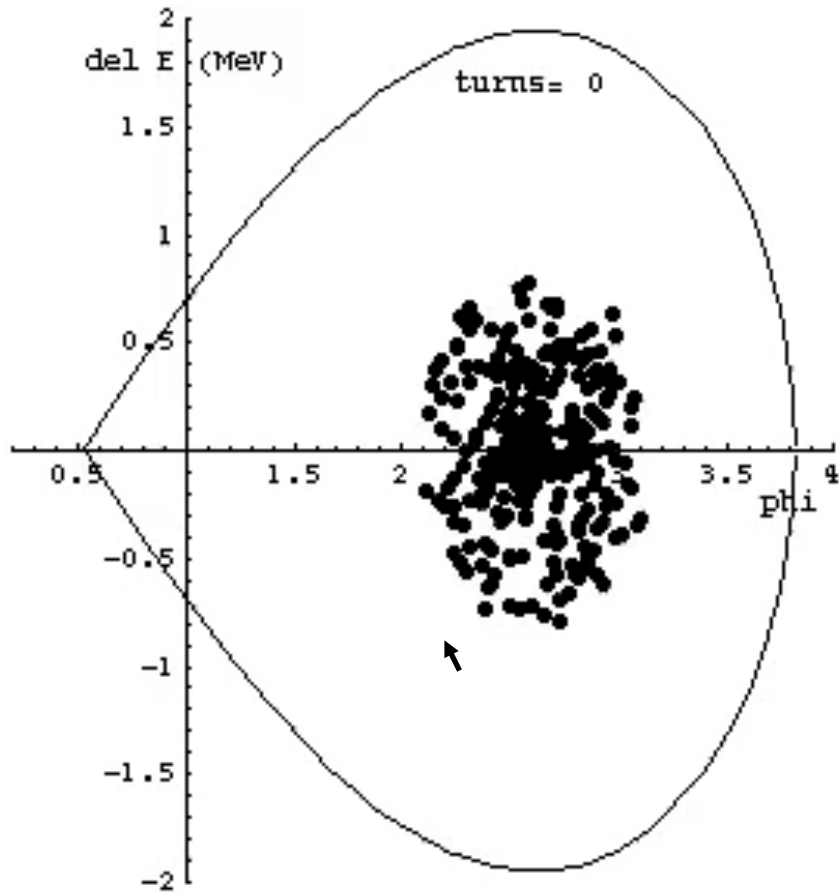

matched beam

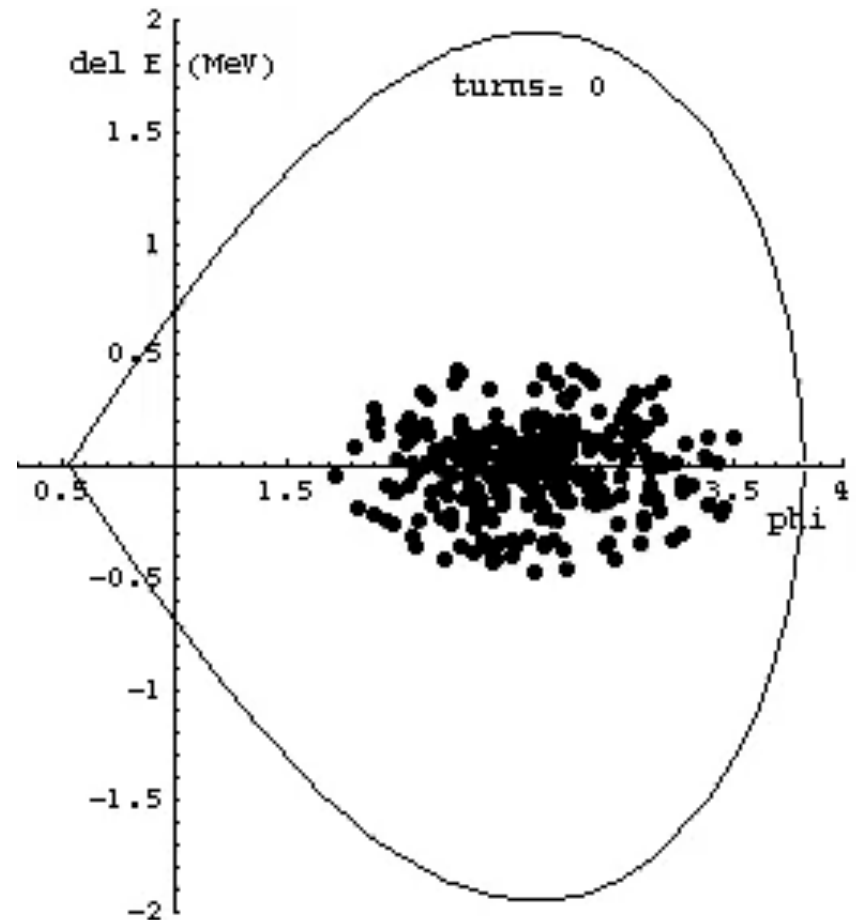

mismatched beam - bunch length

## Effect of a Mismatch (3)

Evolution of an injected beam for the first 100 turns.

For a mismatched transfer, the emittance increases (right).

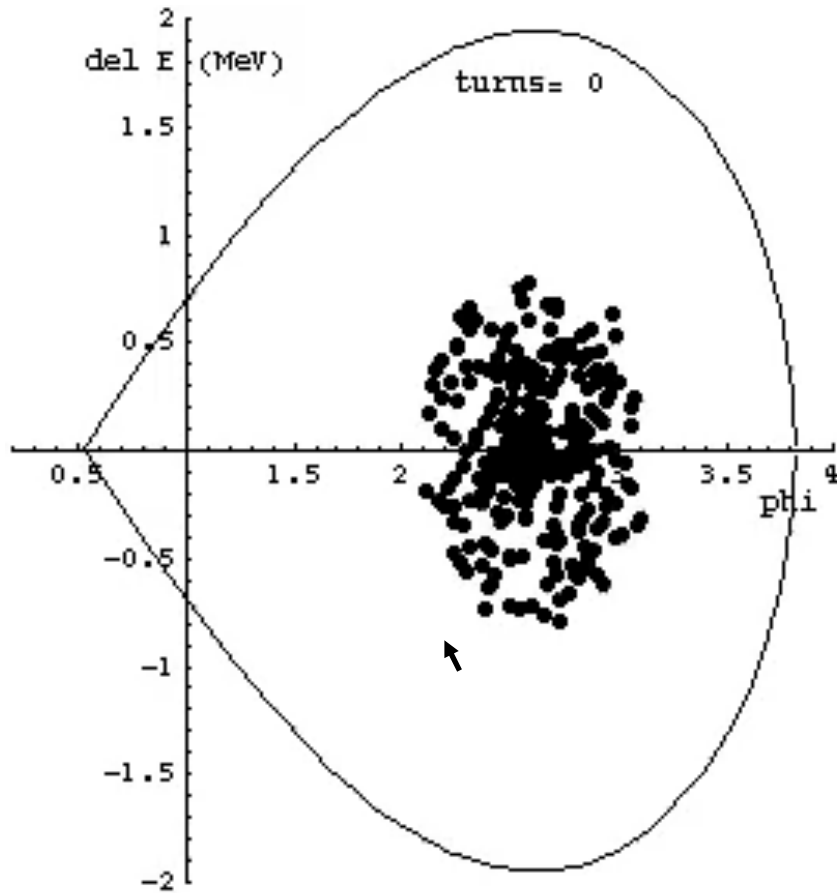

matched beam

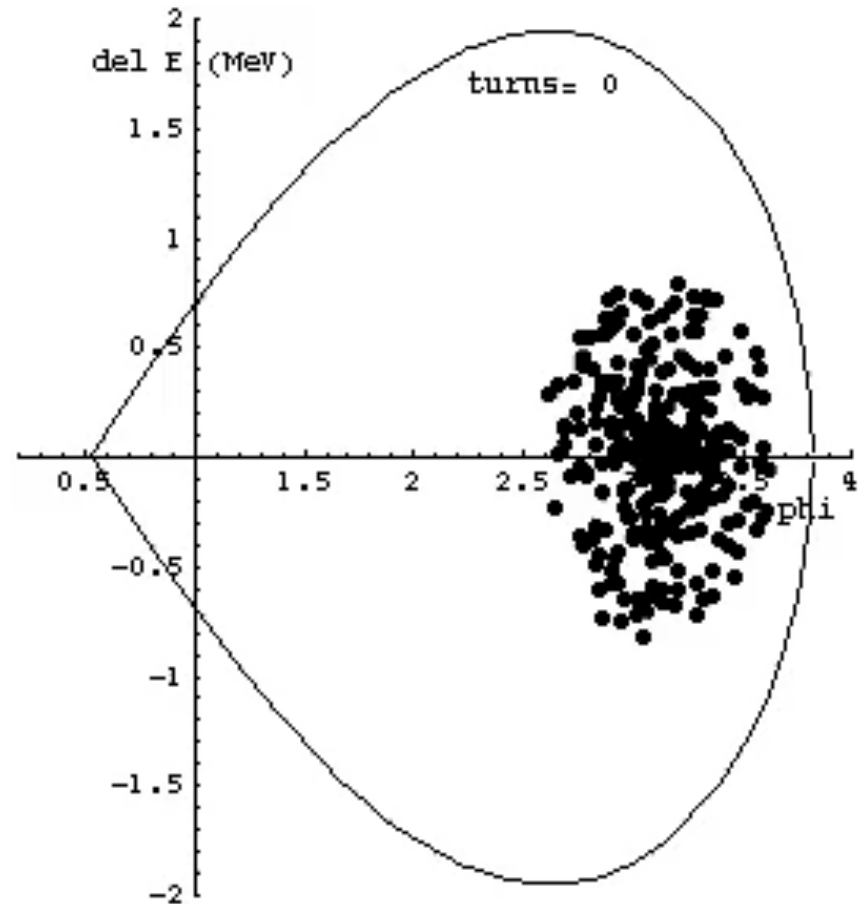

mismatched beam - phase error

# Bunch Rotation

Phase space motion can be used to make short bunches.

Start with a long bunch and extract or recapture when it's short.

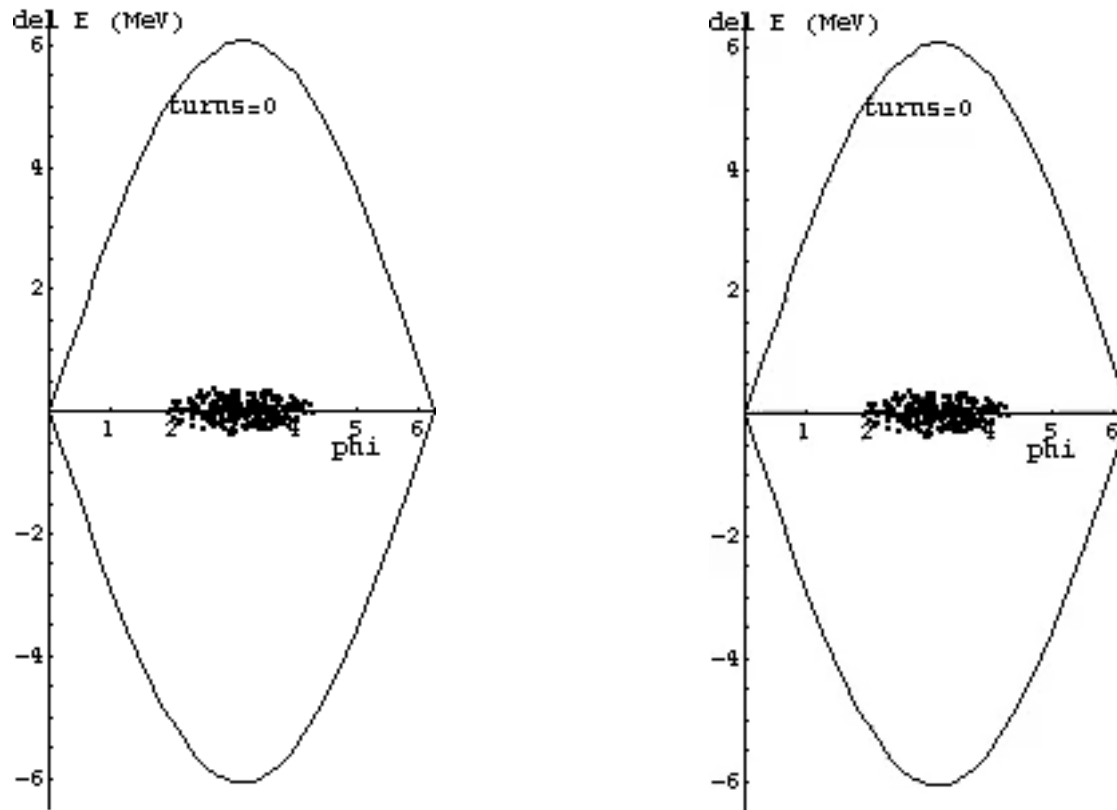

initial beam

# Capture of a Debunched Beam with Fast Turn-On

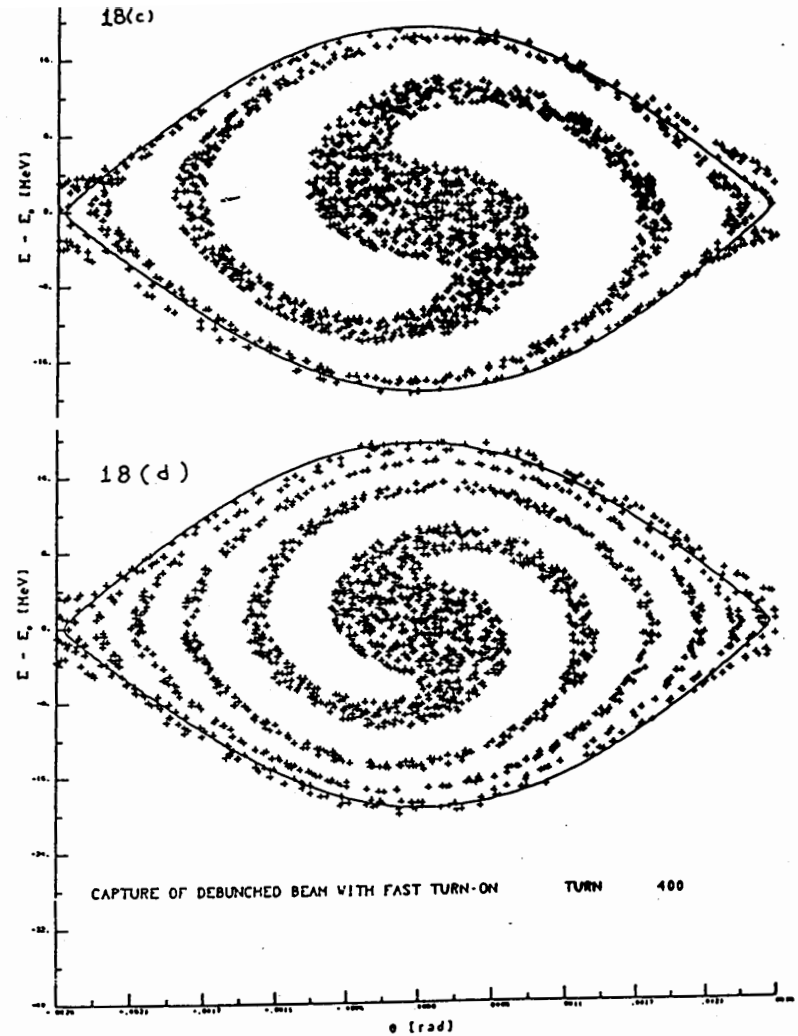
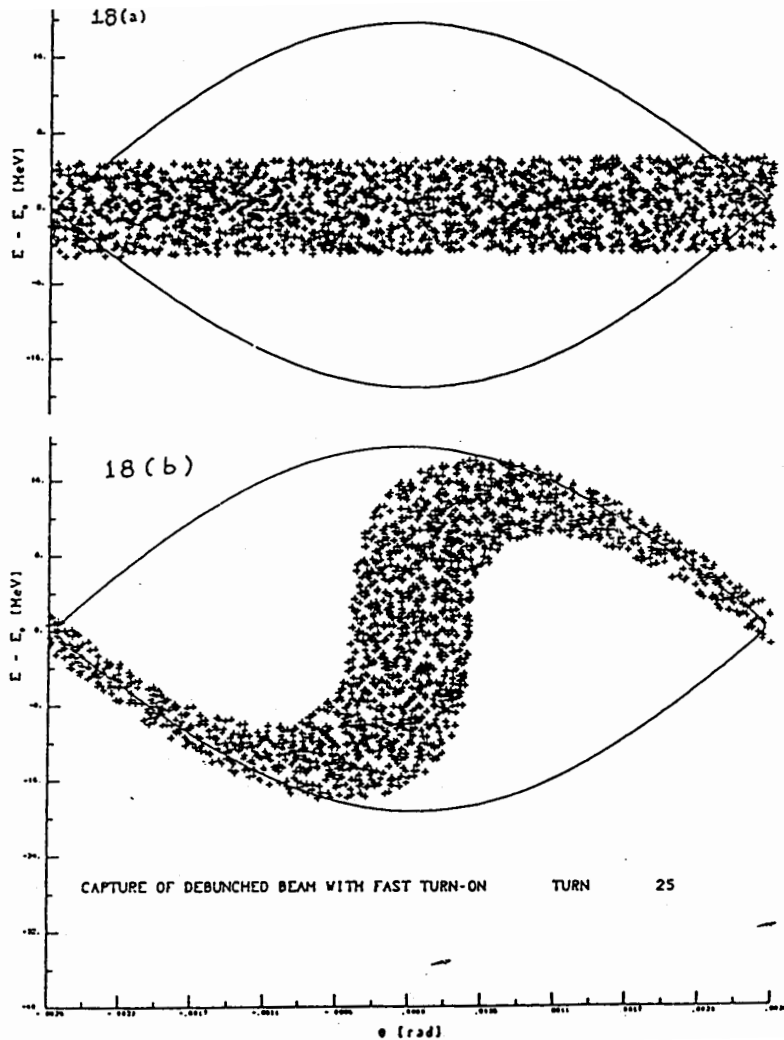

# Capture of a Debunched Beam with Adiabatic Turn-On

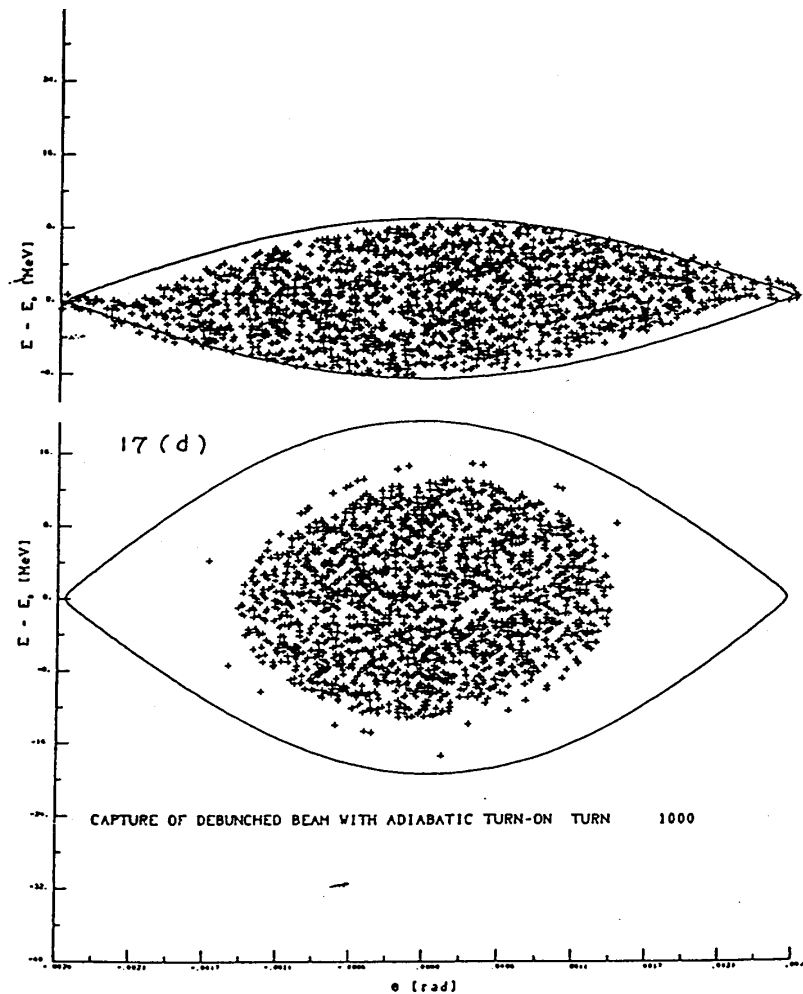
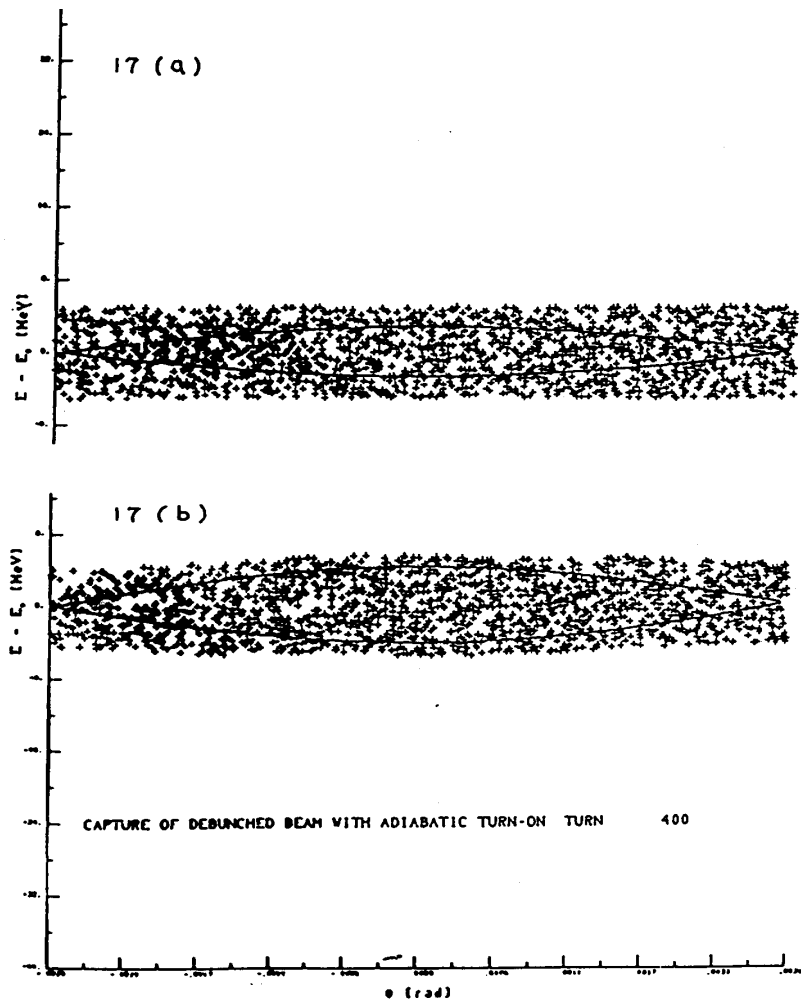

# Generating a 25ns Bunch Train in the PS

- **Longitudinal bunch splitting (basic principle)**

- Reduce voltage on principal RF harmonic and simultaneously rise voltage on multiple harmonics (adiabatically with correct phase, etc.)

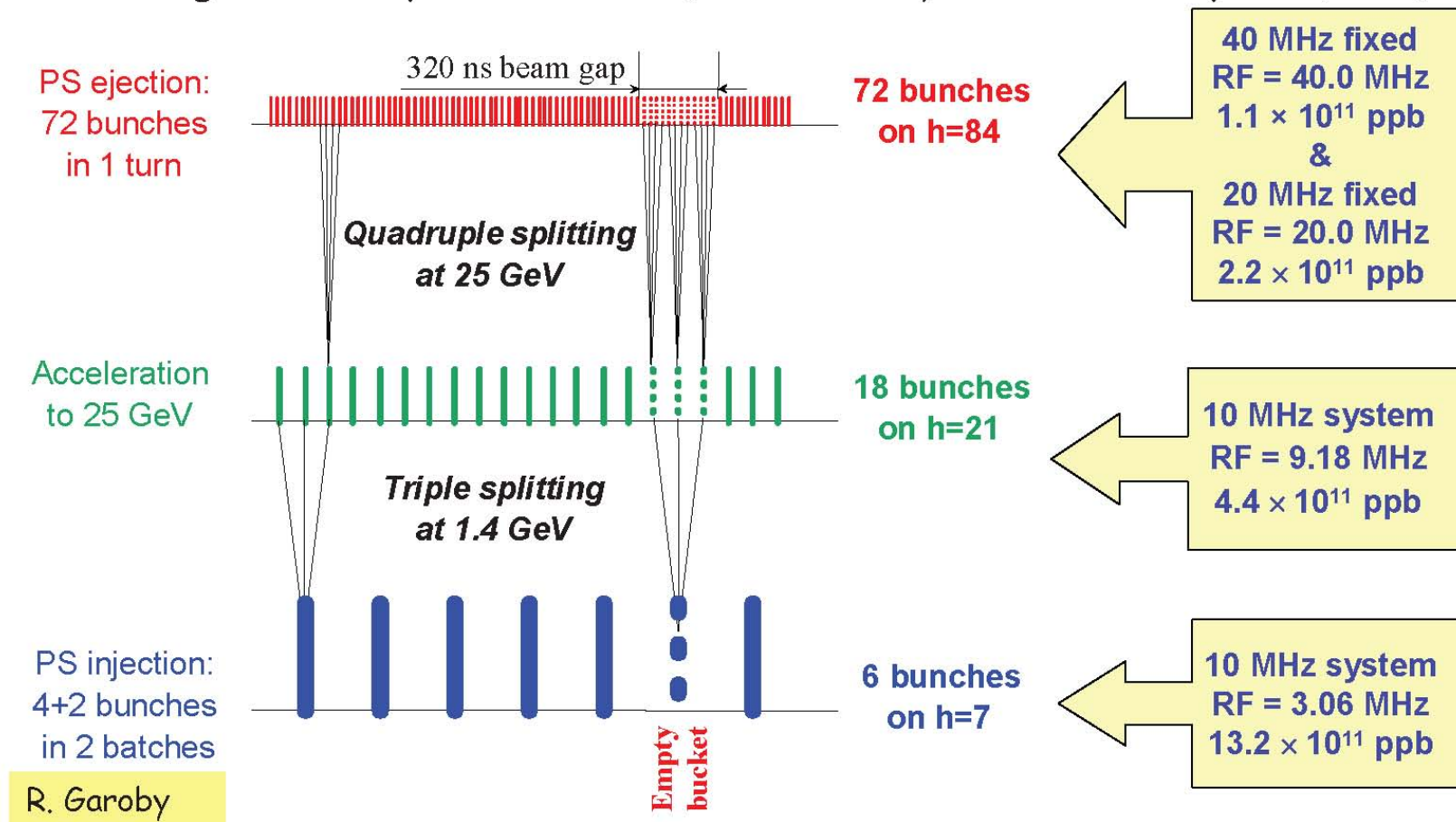

Use double splitting at 25 GeV to generate 50ns bunch trains instead

# Production of the LHC 25 ns beam

1. Inject four bunches  $\sim 180$  ns, 1.3 eVs

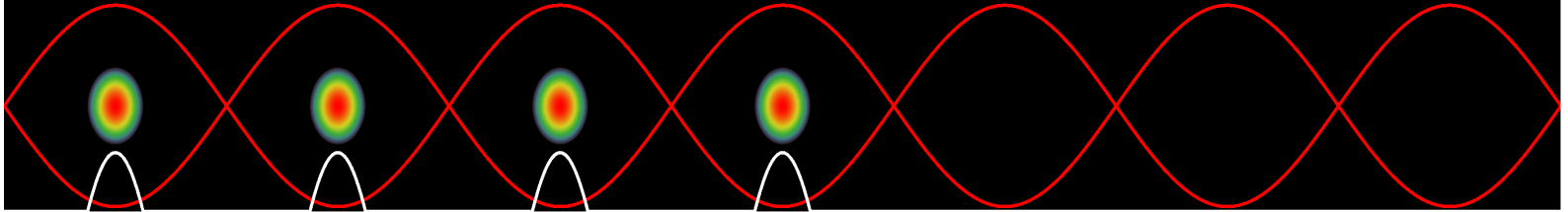

Wait 1.2 s for second injection

2. Inject two bunches

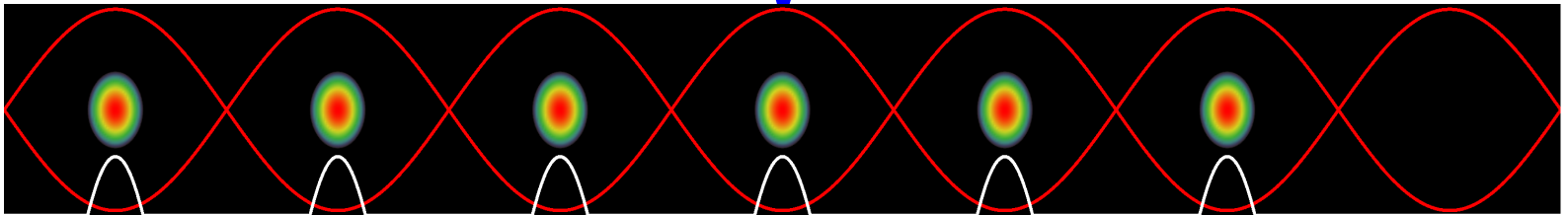

3. Triple split after second injection

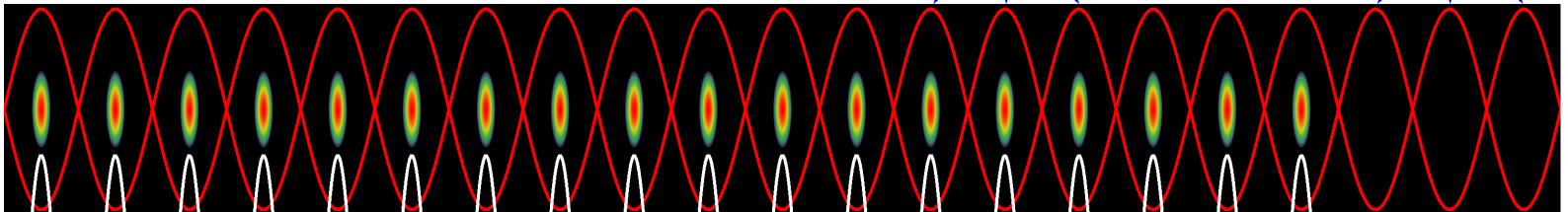

$\sim 0.7$  eVs

4. Accelerate from 1.4 GeV ( $E_{\text{kin}}$ ) to 26 GeV



# Production of the LHC 25 ns beam

5. During acceleration: longitudinal emittance blow-up:  $0.7 - 1.3$  eVs

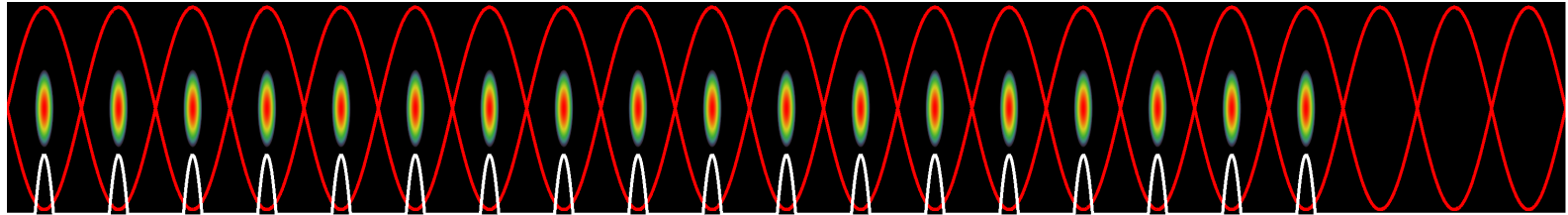

6. Double split ( $h21 \rightarrow h42$ )

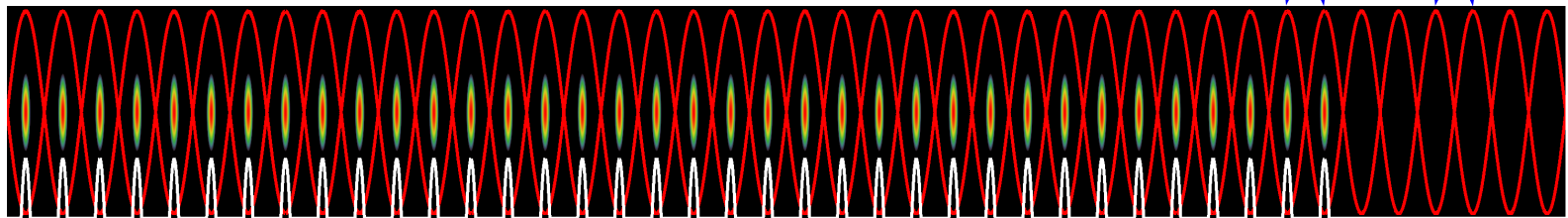

7. Double split ( $h42 \rightarrow h84$ )  $\sim 0.35$  eVs, 4 ns

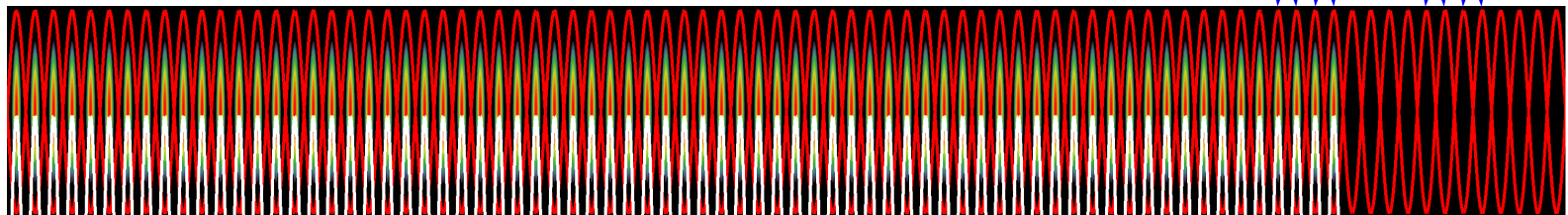

10. Fine synchronization, bunch rotation  $\rightarrow$  Extraction!

# The LHC25 (ns) cycle in the PS

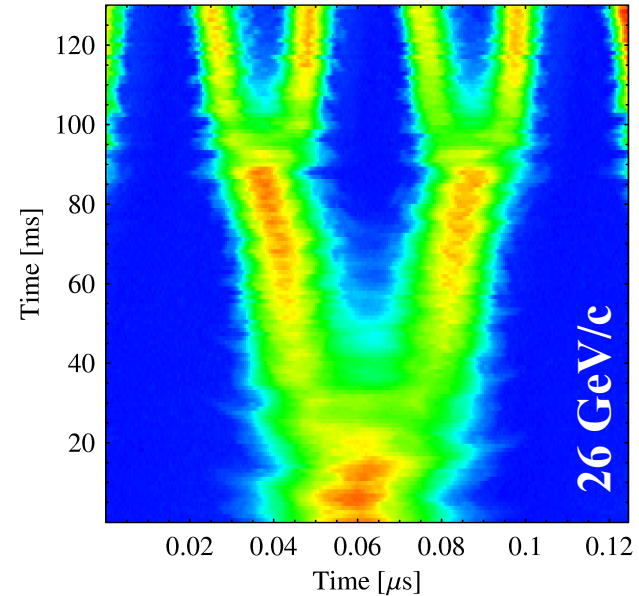
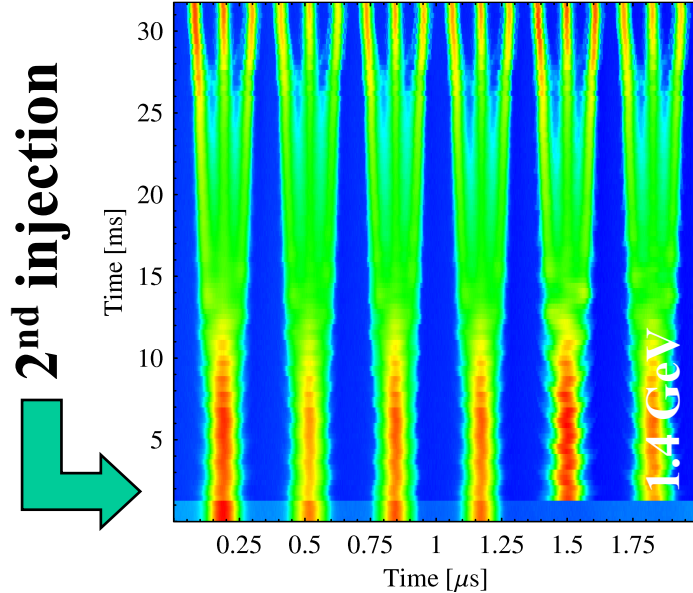
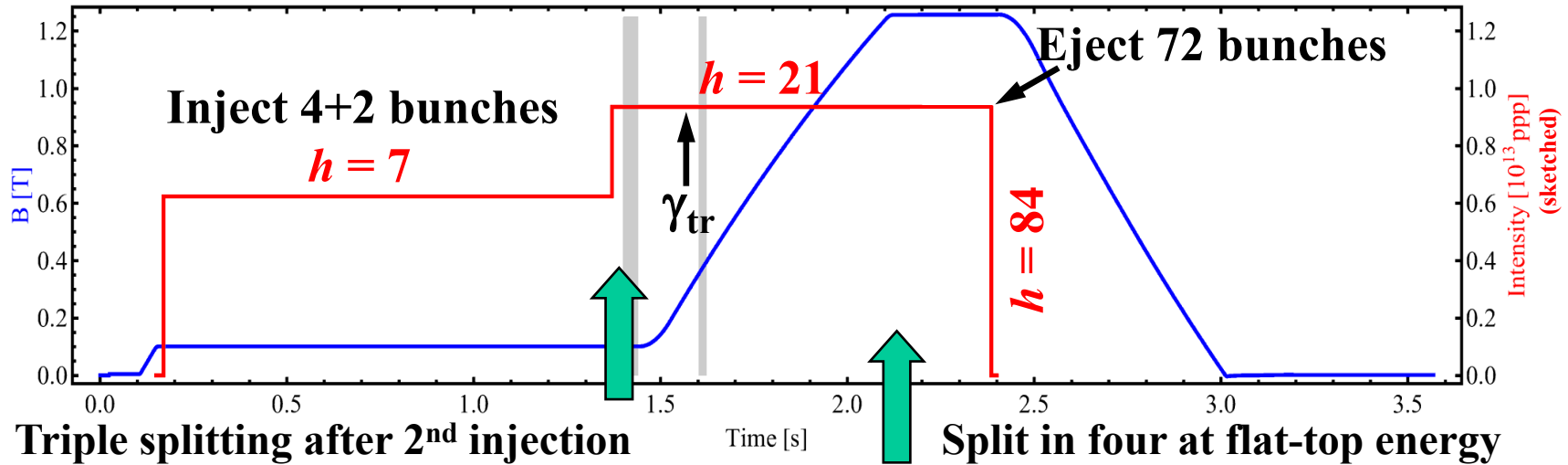

→ Each bunch from the Booster divided by  $12 \rightarrow 6 \times 3 \times 2 \times 2 = 72$

# Triple splitting in the PS

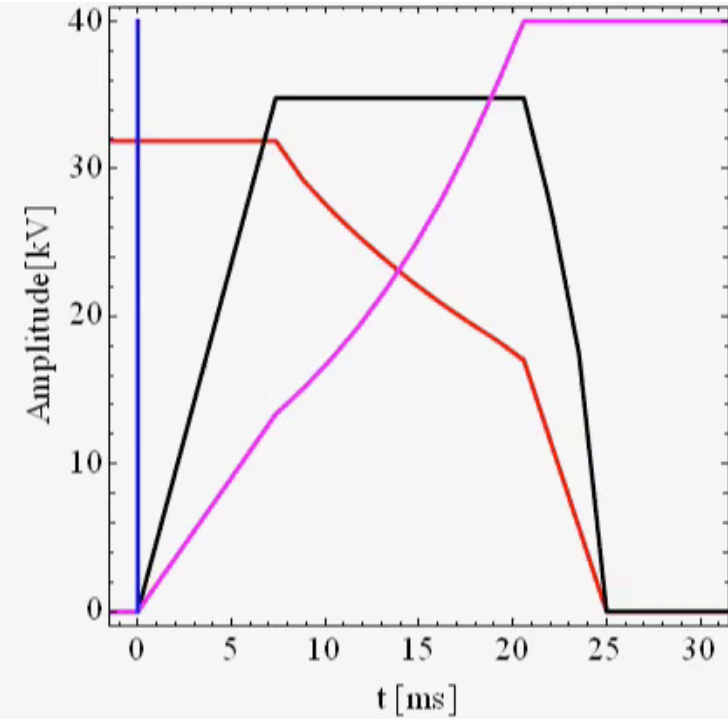
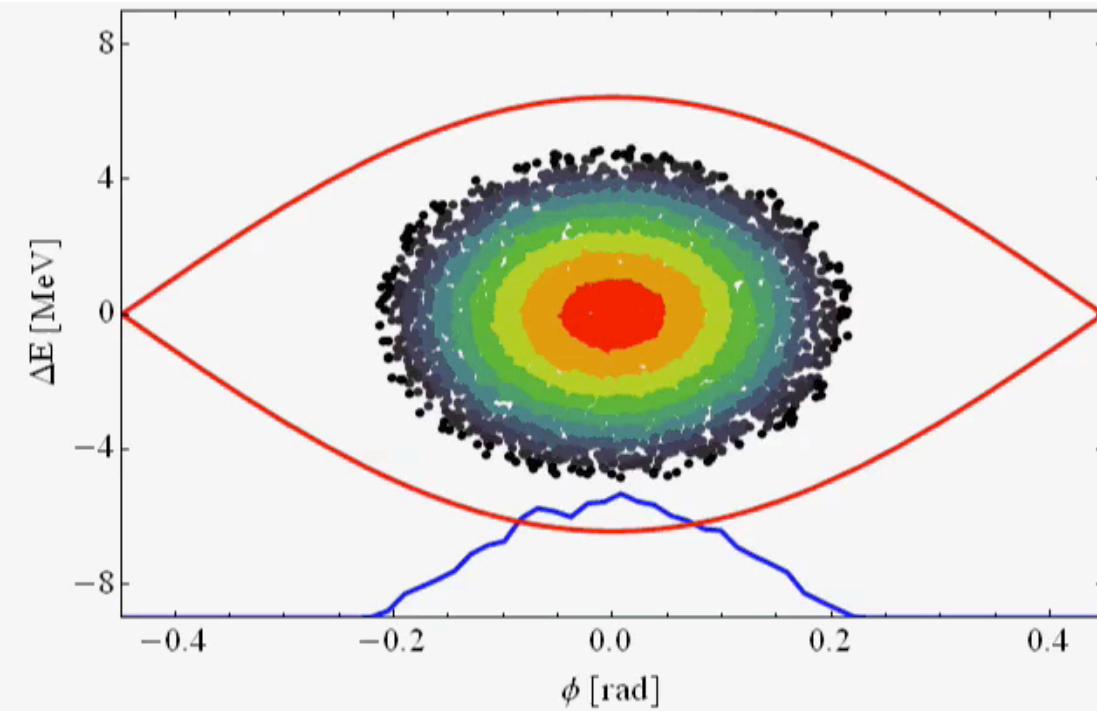

# Two times double splitting in the PS

Two times double splitting and bunch rotation:

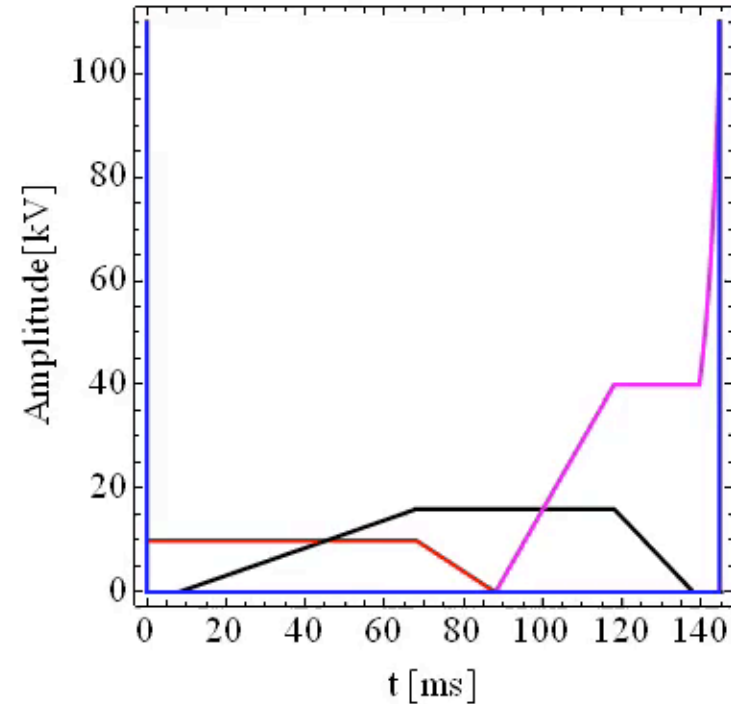
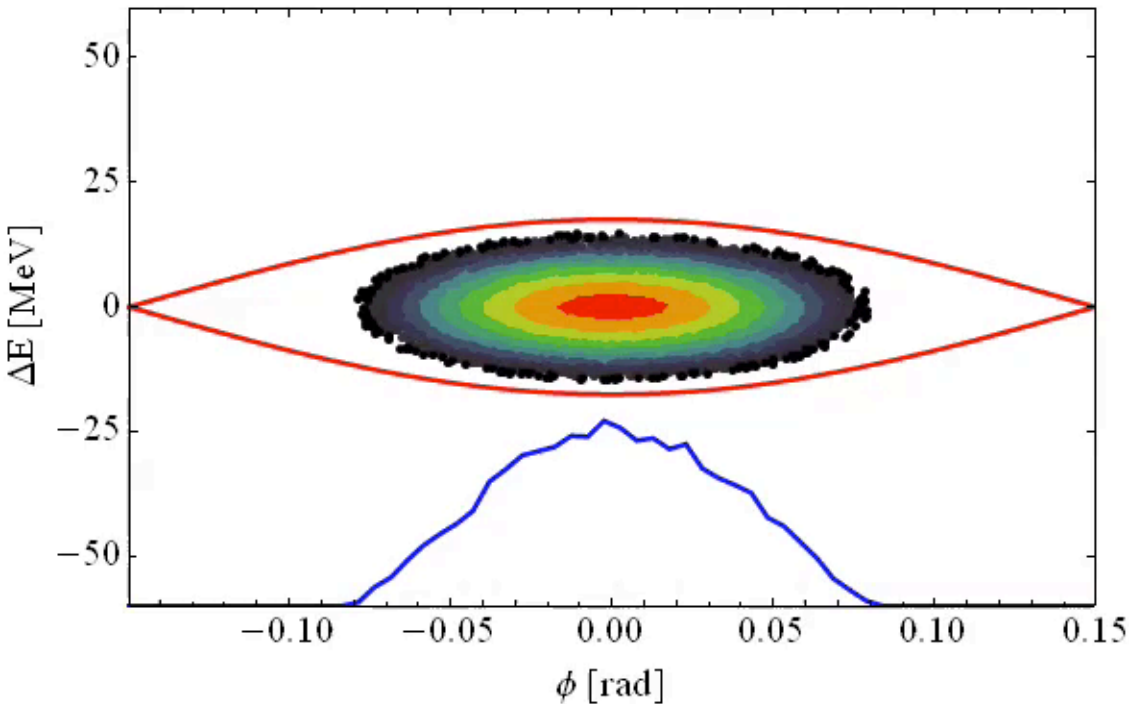

- Bunch is divided twice using RF systems at  $h = 21/42$  (10/20 MHz) and  $h = 42/84$  (20/40 MHz)
- Rotation: first part  $h84$  only +  $h168$  (80 MHz) for final part

## Summary

- Cyclotrons/Synchrocyclotrons for low energy
- **Synchrotrons** for high energies  
constant orbit, rising field and frequency
- Particles with higher energy have a longer orbit (normally) but a higher velocity
  - at low energies (below transition) velocity increase dominates
  - at high energies (above transition) velocity almost constant
- Particles perform **oscillations around synchronous phase**
  - synchronous phase depending on acceleration
  - below or above transition
- **bucket** is the region in phase space for stable oscillations
- matching the shape of the bunch to the bucket is important

# Bibliography

- M. Conte, W.W. Mac Kay **An Introduction to the Physics of particle Accelerators**  
(World Scientific, 1991)
- P. J. Bryant and K. Johnsen **The Principles of Circular Accelerators and Storage Rings**  
(Cambridge University Press, 1993)
- D. A. Edwards, M. J. Syphers **An Introduction to the Physics of High Energy Accelerators**  
(J. Wiley & sons, Inc, 1993)
- H. Wiedemann **Particle Accelerator Physics**  
(Springer-Verlag, Berlin, 1993)
- M. Reiser **Theory and Design of Charged Particles Beams**  
(J. Wiley & sons, 1994)
- A. Chao, M. Tigner **Handbook of Accelerator Physics and Engineering**  
(World Scientific 1998)
- K. Wille **The Physics of Particle Accelerators: An Introduction**  
(Oxford University Press, 2000)
- E.J.N. Wilson **An introduction to Particle Accelerators**  
(Oxford University Press, 2001)



**And CERN Accelerator Schools (CAS) Proceedings**

# Acknowledgements

I would like to thank everyone for the material that I have used.

In particular (hope I don't forget anyone):

- Joël Le Duff (from whom I inherited the course)
- Rende Steerenberg
- Gerald Dugan
- Heiko Damerau
- Werner Pirkl
- Genevieve Tulloue
- Mike Syphers
- Daniel Schulte
- Roberto Corsini
- Roland Garoby
- Luca Bottura
- Berkeley Lab
- Edukite Learning