

Thank you
for your enthusiasm



Congratulations

for the quality of the work



**Thanks & Congratulations
to
Barbara and Daniel
for their support**

In general well understood

Particle	electron
Design Energy	3 GeV
Deflection Angle	0.174533 rad
Max. length available	2.2 m
Flux Density	1.746 Tm
Integrated Gradient	4.58 T
Integrated Sextupole Component	18 T/m
Good Field Region	+/- 15mm in x
Vacuum Chamber	48x19.6mm
Max. Temperature Rise	11 K
Max. Pressure Drop	7 bar
Repetition Rate	3 Hz

Magnet Requirements:

To design a combined function magnet with the following properties for a clockwise electron booster synchrotron:

Integrated Dipole Component: -1.74625 Tm
 Integrated Defocusing Quadrupole Component: 4.58 T
 Integrated Defocusing Sextupole Component: 18 T/m

The proposal for this magnet is that it have a magnetic length of 2.00m with an average gap of 0.03m. This means a peak field of 0.873T, which is produced with 16 windings per pole. The windings will comprise square copper, 18mm on a side, with a central cooling channel of 5.5mm radius. This corresponds to a copper cross section of 228.9mm². Assuming a maximum current of 800A (nominal current of 667A), for this coil dimension, the maximum required current density will be 3.5A/mm².

Parameters	Units	Value
Beam Energy	GeV	3
Field Integral	Tm	1.75
Field Gradient Integral	T	4.58
Integrated Sextupole	T/m	18
Bending Angle	°	10
Central Gap	mm	>19.6mm
Maximum Length of Iron	m	2.2
Maximum Length of Magnet	m	2.5
Maximum Extent of Coil	mm	150
Maximum Temperature Rise	°C	11
Maximum Pressure Drop	bar	7

1. Design Report

1.1 Requirements

A combined function magnet for the Booster of the Spanish Synchrotron on Source ALBA is needed. The requirements are summarized in table 1.1.

Beam and Field Requirements	
Beam Energy E	3 GeV
Integrated Flux Density $\int B_x dx$	-1.74625 Tm
Integrated Field Gradient $\int G dx$	4.58 T
Integrated Sextupole Component $\int B'' dx$	18 T/m
Good Field Region	$ x \geq 15$ mm
Repetition Frequency f_{rep}	3 Hz
Geometrical Requirements	
Elliptical Vacuum Chamber	48 mm x 19.6 mm
Maximum Length incl. Coils	2.5 m
Power Requirements	
Maximum Available Current	800 A
Maximum Temperature Rise ΔT	11 degrees
Maximum Pressure Drop	7 bar

Table 1.1: Requirements

1.2 Magnet Cross Section

The cross section of the dipole magnet is given in figure 1.3. To optimize the pole shoe geometry weighting and shimming function were superposed to the

1. Design Report

analytical function of the pole shoe of a dipole with quadrupole and sextupole components. The profile curve of the pole shoe is shown in figure 1.1 and the coordinates in 1.2.

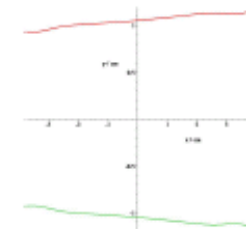

Figure 1.1: Pole Shoe Profile

x [mm]	y [mm]
-2.500	09.000
-2.000	09.000
-1.500	09.000
-1.000	09.000
-0.500	09.000
0.000	09.000
0.500	09.000
1.000	09.000
1.500	09.000
2.000	09.000
2.500	09.000

CASE STUDY : coil design

In general too few details on coil design, with three exceptions

Extreme case 8 mm cooling channel : pressure drop only 1.4 bar

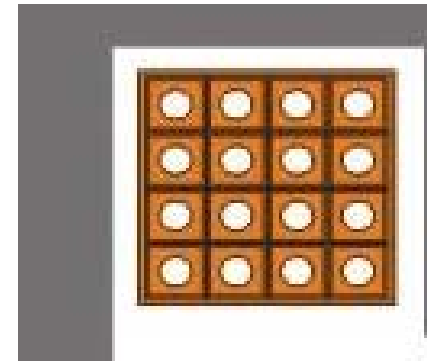
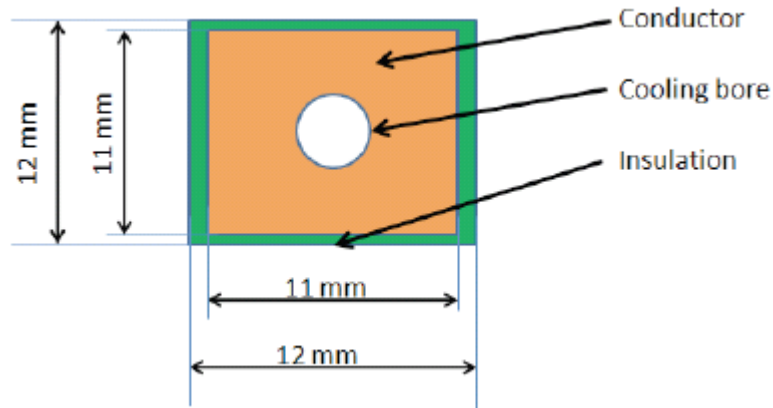
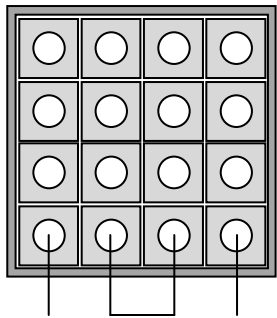

Final cross check of parameters sometimes missing

CASE STUDY : magnet cross section

Sometimes magnet size could have been better optimized

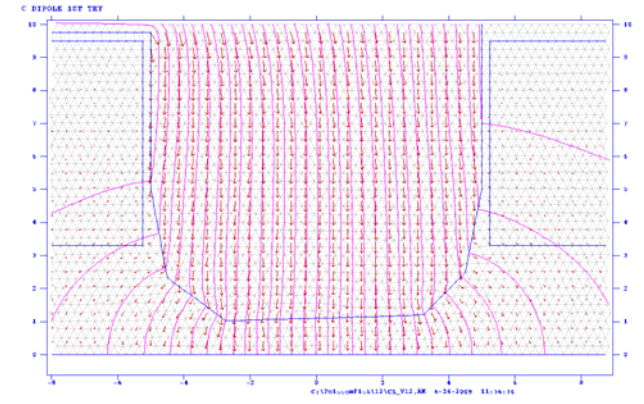
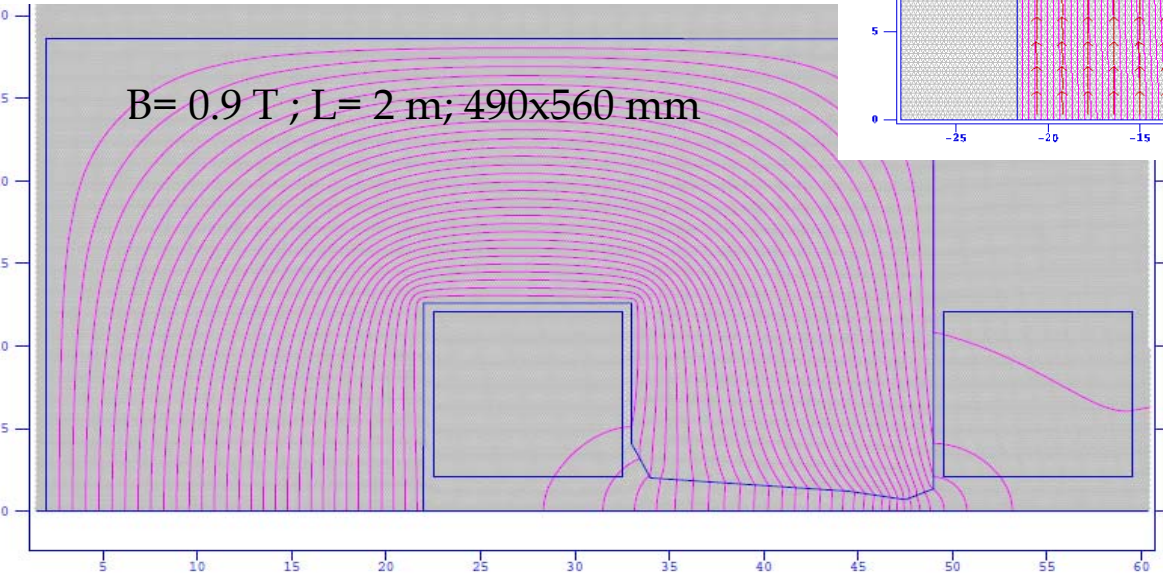
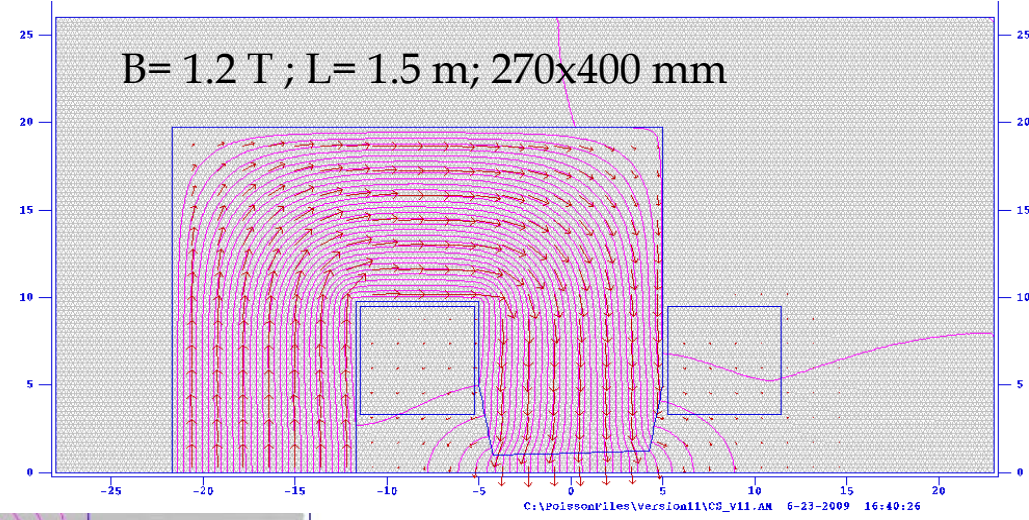
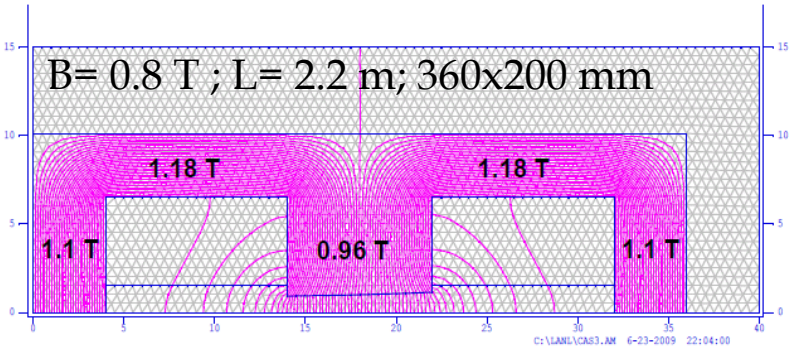

CASE STUDY : magnet cross section

Pocket magnets

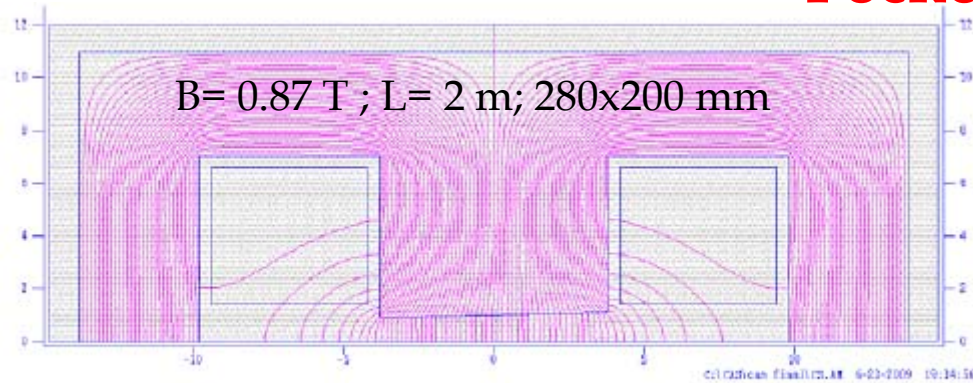
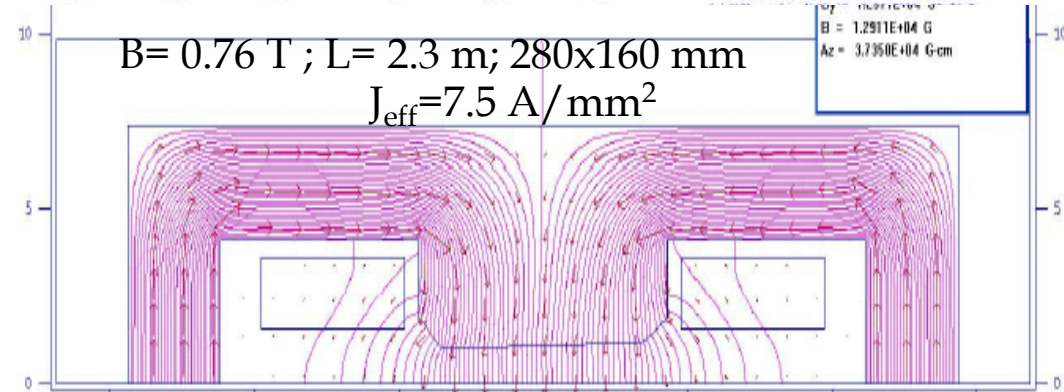
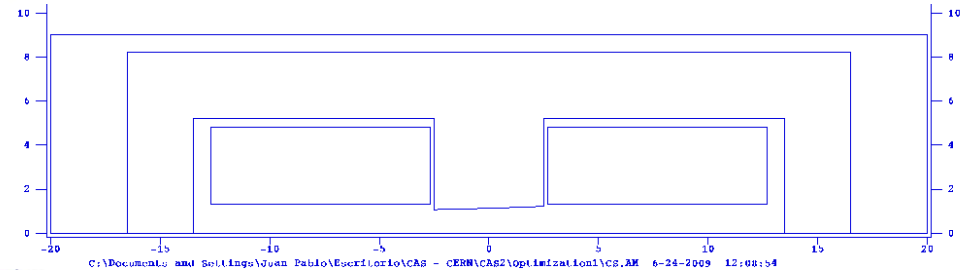
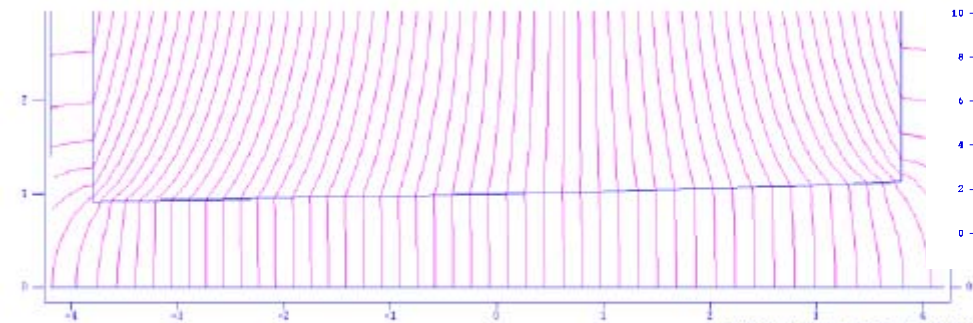
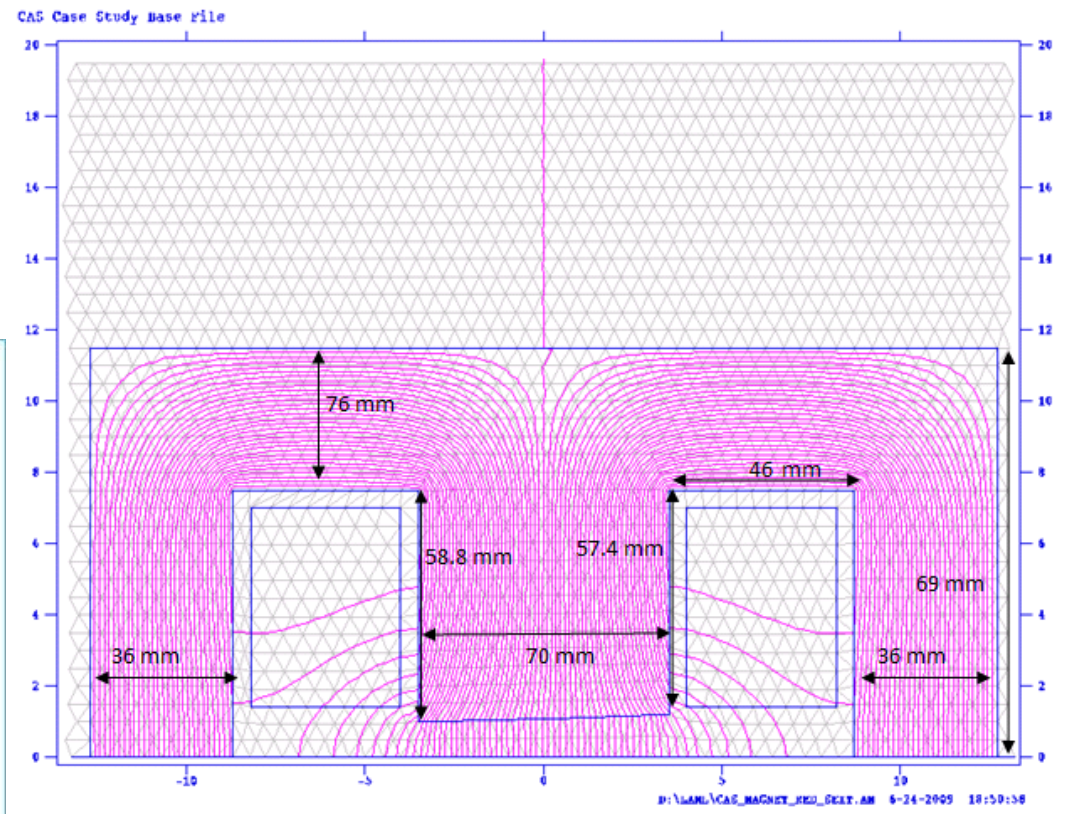
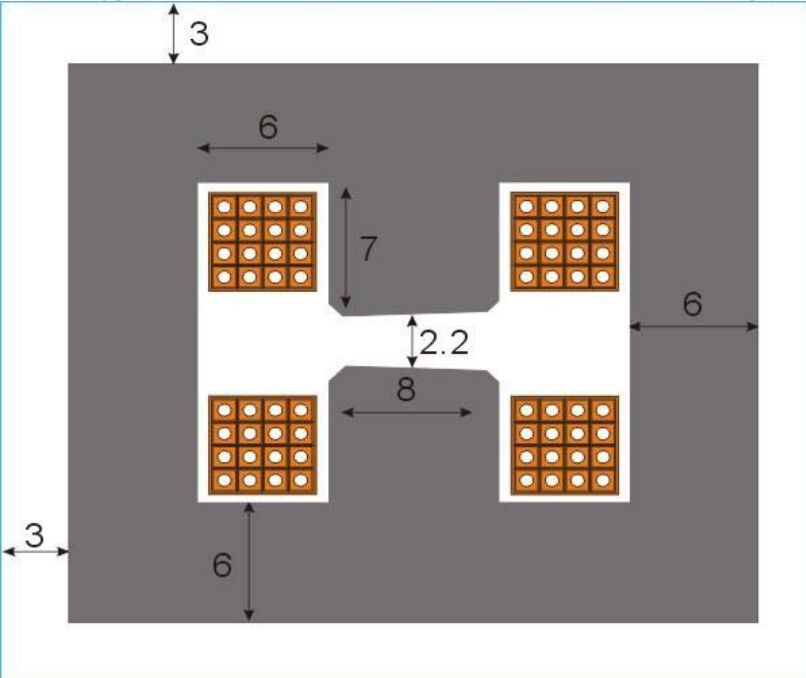
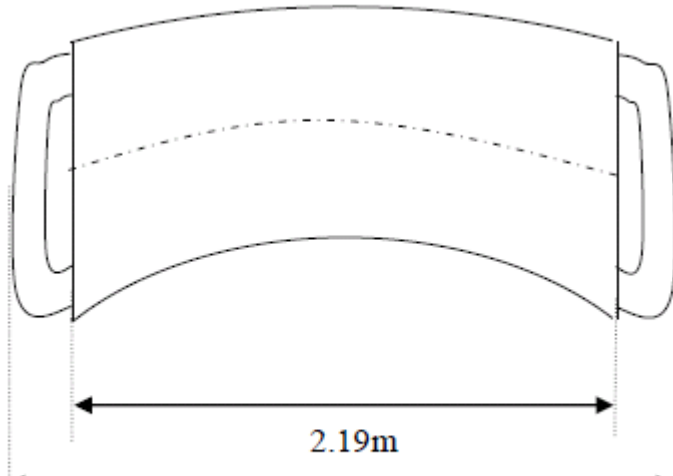

Figure 1 - Magnet (half) cross section

Quad	B'	2.290E+00	T/m
Sex	B''	1.800E+01	T/m ²
Magnetic Length			
	L _{iron}	1.978E+00	m
	L	2	m
	X0	3.811E-01	
	X1_2	9.898E-02	
Ampereturns	N _{basic}	7.018E+03	A
Ampereturns	N _I	8.000E+03	A
Current	I	5.000E+02	A
Turns per coil	N	1.600E+01	
Stored Energy			
	faktor	2.750E+00	
	L _{avg}	5.500E+00	m
	U _{gap}	1.280E+03	Ws



CASE STUDY : drawings



Optimization of cross section

- Modeling
- Saturation
- Iron size and shape (trimming)
- Pole profile
- Symmetries

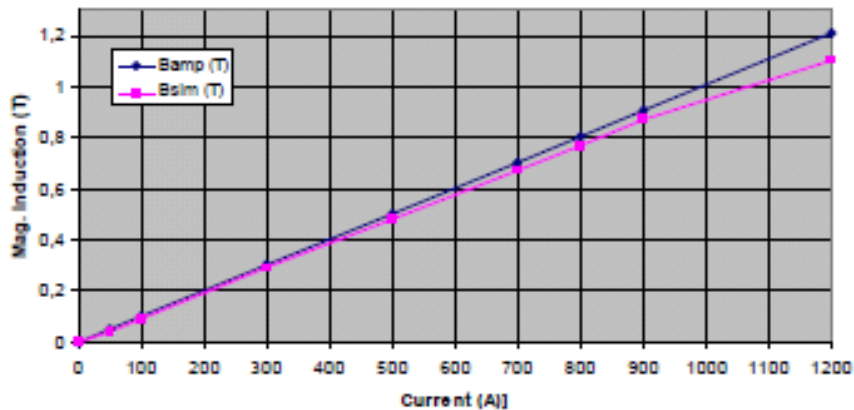

Field error

$$\Delta B / B = \frac{B_{meas} - B_{wanted}}{B_{wanted}}$$

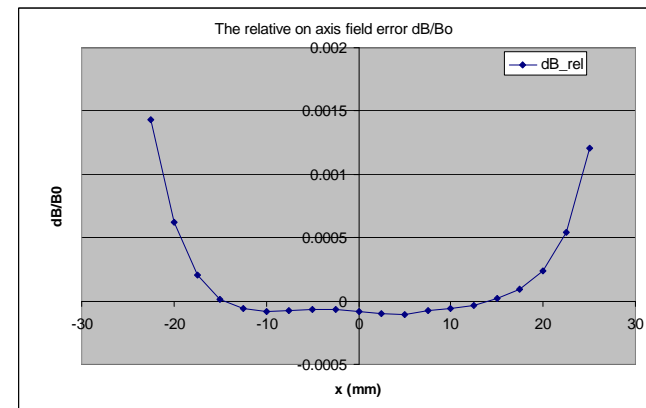
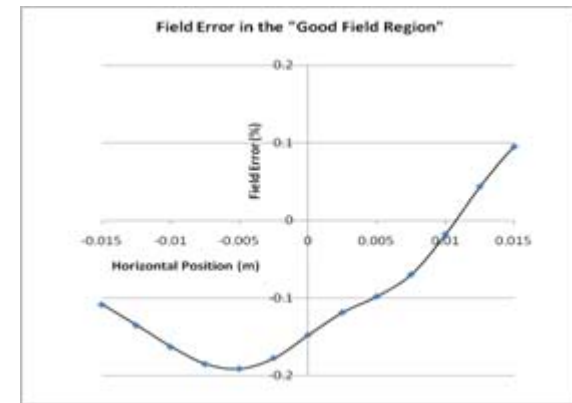

CASE STUDY : numerical field analysis

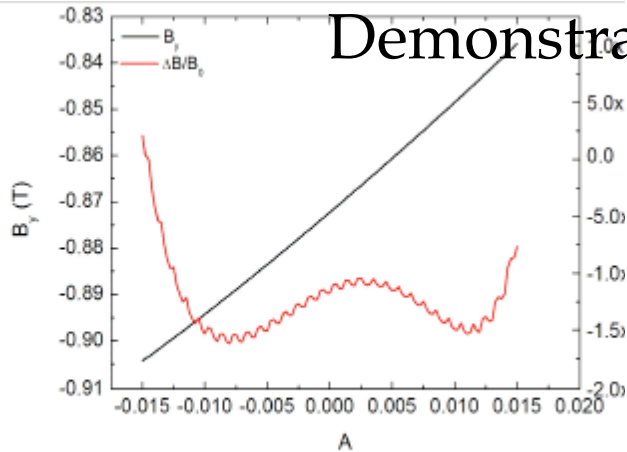

Demonstration of best practice

Illustration 3: Field and field quality in the magnet median plane

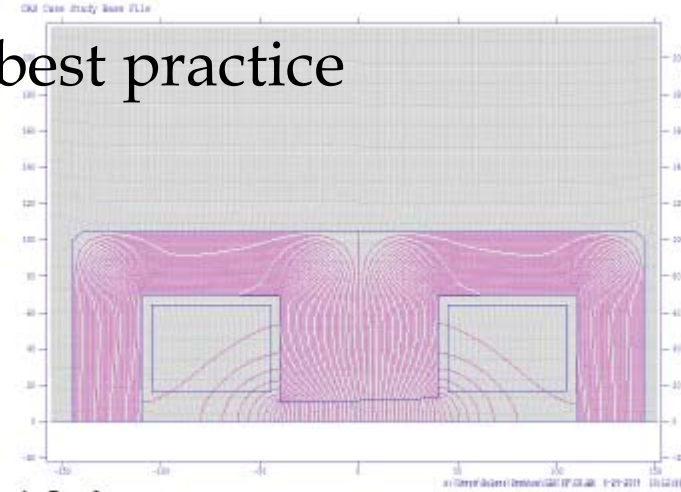
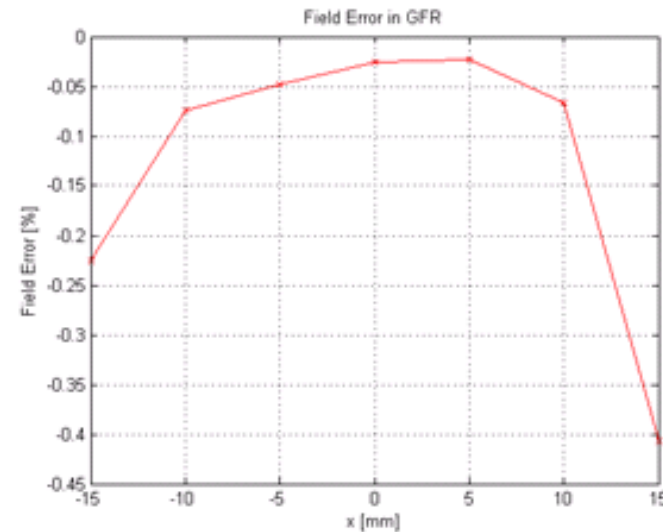
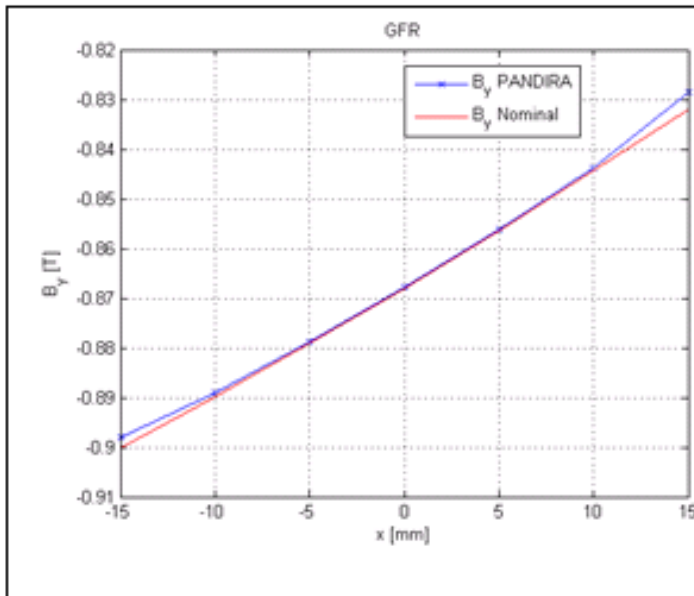

Illustration 4: flux lines

Magnetization of the yoke is in the 1.2–1.5 T (illustration 5). Magnet efficiency is about 96.5 %



CASE STUDY : design parameters

Important parameters sometimes missing or wrong :

- electrical resistance
- supply voltage
- pressure drop
- magnet weight

Different formats

Length of yoke: 1.95 m
 Coil & Conductor
 Number of coils: 2
 Number of turns per coil: 4
 Number of turns per pancake: 8
 Conductor size: 15 mm x 15 mm
 Cooling channel diameter: 4 mm
 Number of cooling circuits per coil: 1
 Current: 691 A (peak value)
 Current density: 4 A/mm²
 Inductance: 100 mH
 Voltage drop: 65.5 V
 Power: 4.515 kW
 Cooling
 Max pressure drop: 1.44 bar
 Nominal inlet temperature: 23°C
 Number of cooling circuits: 4 per coil
 Max pressure drop (magnet overall): 1.44 bar

Magnetic Properties	
Beam Energy	3 GeV
Central Field	1.2 T
Field Gradient	3.15 T/m
Sextupole component	12.4 T/m ²
Effective Length	1.454 m
Mechanical Properties	
Bending radius R_0	8.333 m
Bending angle, ϕ	10°
Central gap, h	22 mm
Length of yoke	1.430 m
Coil and conductor	
Number of coils	2
Number of pancakes per coil	2
Number of turns per pancake	8
Conductor size	15 x 15 mm = 225 mm ²
Cooling channel diameter	8 mm
Number of ampere turns per coil	11057
Current	691 A
Current density	3.95 A/mm ²
Resistance at 23 degrees C	12.6 mΩ
Inductance	9.7 mH
Voltage Drop (whole magnet)	127 V
Power	4.515 kW
Cooling	
Maximum Δt	10°
Nominal input temperature	23°
Number of cooling circuits per coil	1
Max pressure drop (magnet overall)	1.44 bar

Parameters	Units	Nominal Values	15% Extra
Beam Energy	GeV	3.00	3.45
Field Integral	Tm	1.75	2.00
Magnetic Arc Length	m	2.2	2.2
Magnetic Field at Centre	T	0.79	0.91
Central Field Gradient	T/m	2.10	2.38
Central Sextupole Component	T/m ²	8.1	9.37
Curvature Radius	m	12.6	12.6
Central Gap	mm	26.0	26.0
Total Ampere Turns	-	16420	18880
Total Turns	-	72	72
Peak Current	A	228	262
Conductor Cross Section	mm	9 x 9	9 x 9
Conductor Cooling Channel Diameter	mm	3.5	3.5
Total Number of Pancakes	-	6	6
Magnet Resistance	Ω	95	95
Magnet Voltage at Maximum Current	V	21.7	25.0
Average Power (AC)	kW	2.5	3.3
Inductance	mH	69	69
Cooling Fluid Velocity	m/s	0.95	1.25
Pressure Drop	bar	2.87	4.67
Temperature Rise	°C	11	11

CASE STUDY : conclusions

Overall results certainly beyond expectations

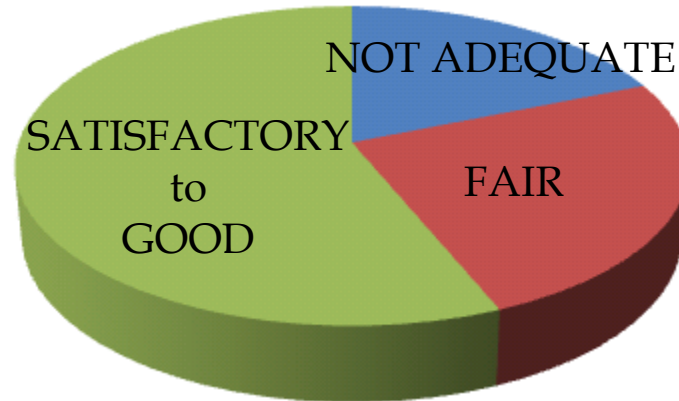

To improve

- schematic representation of a magnet
- representation of cooling circuits
- magnetic modeling, in particular setting boundaries
- the optimization loop, in particular pole width, magnet size, reduce iron saturation
- mastering certain fundamental concepts :
 - magnetic energy : what is, how to compute
 - inductance : what is, how to compute
 - powering : resistive and inductive voltage, effective current
 - magnetic field quality and errors : practical use of field harmonics
- the compilation of a magnet design report
- cross check the results