

Capacitor in power inverter

Roland Gallay, Garmanage

8 May 2014

A

T

M

S

L



Applications in power inverter

1. Applications in power inverter

1. Snubber, clamp, resonant, DC-link

2. Capacitor technologies

1. Electrochemical, electrolytic, film foil, metalized film

3. Equivalent model

4. Properties and specifications

5. Ageing

A

T

M

S

L



Applications of capacitors in Inverter

1. DC filter

1 nF 220 μ F

2. DC link

1 nF 3800 μ F

3. Snubber

1nF 8 μ F, Low inductance

4. Output filter

1 nF 600 μ F

5. Resonant

1 nF 600 μ F, +/-2%

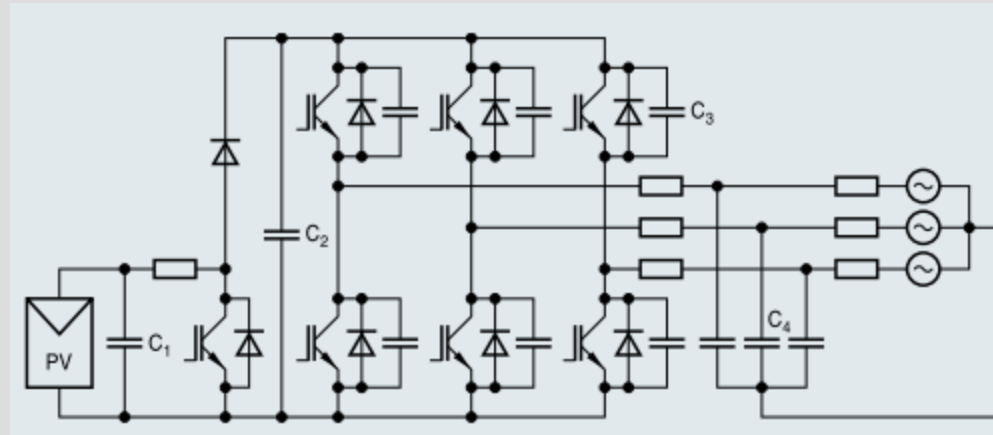

Epcos MKP FC Solar Inverters

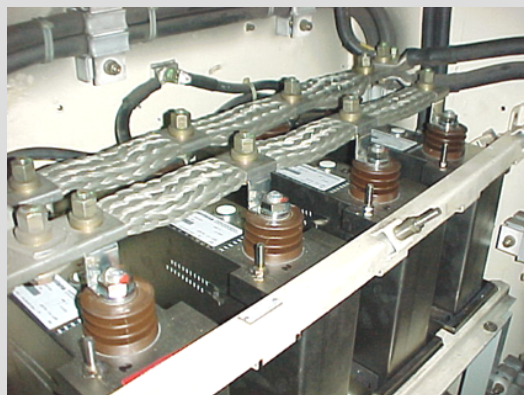

TGV input filter
1800VDC
8 mF



ABB traction Inverters



DC-link

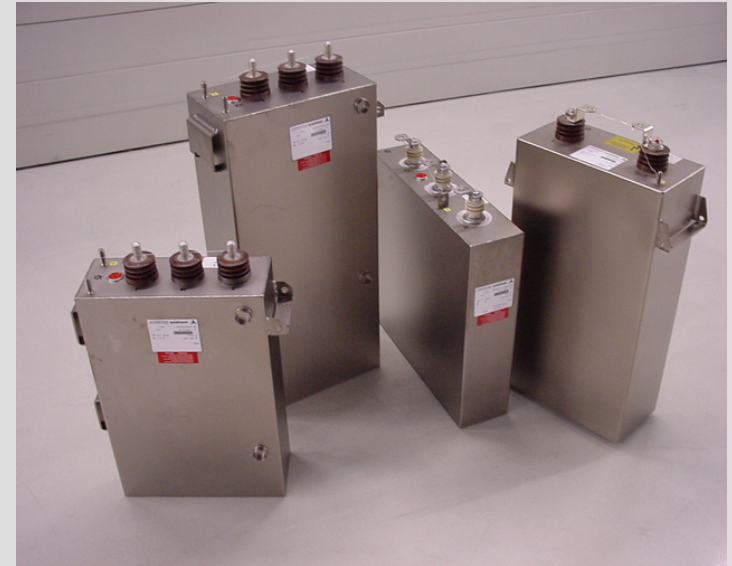
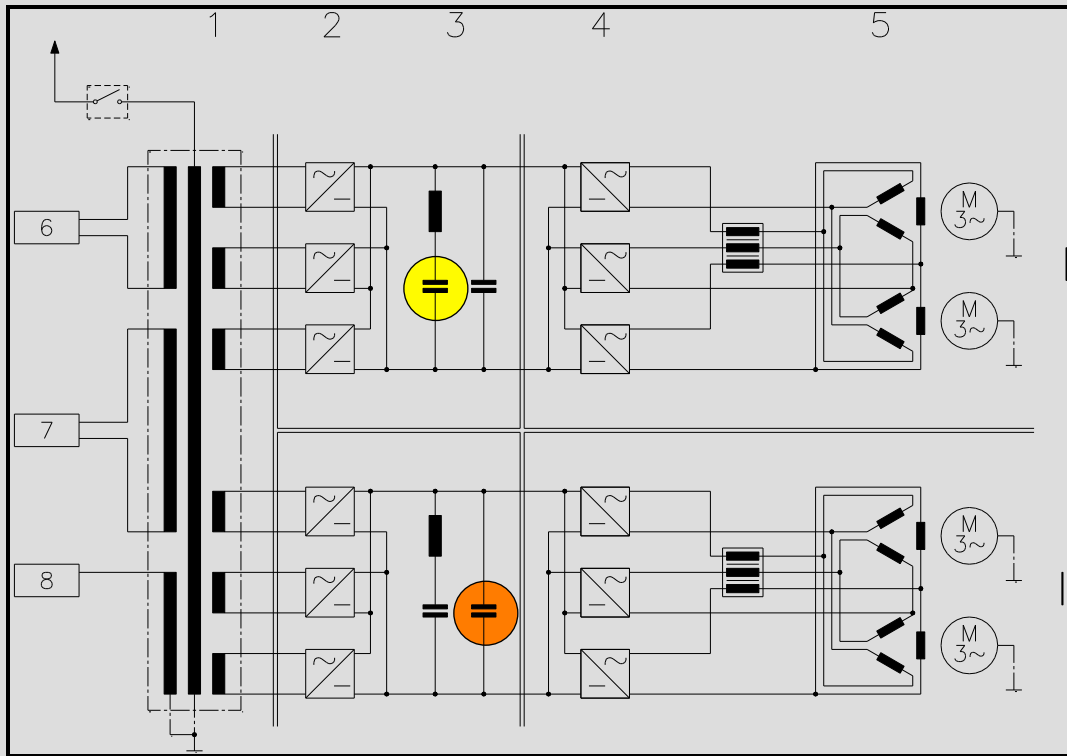



-  Resonant capacitor (Saugkreiskondensator)
-  DC-link (Zwischenkreiskondensator)

ABB Lok2000 electrical design

A
T
M
S
L



Resonant capacitors

Used to tune series or parallel resonant circuits used in industrial medium-frequency systems (resonant converters)

- Frequencies between several hundred Hz and several hundred kHz
- Relatively tight tolerances: often $\Delta C/C \leq 2\%$
=> exclusion of certain dielectrics
- Only constraints to take into account:
 - voltage peak value (must remain smaller than U_n)
 - current rms-value (dielectric losses, ohmic losses)

A

T

M

S

L



Commutation capacitors (snubber)

Deliver current pulses necessary to block thyristors

- Severe constraints, complex applied waveforms
- Classical thyristors disappear gradually replaced by GTO/IGCT and IGBT. These active components do not need turn-off commutation capacitors.
- Voltage continuous, rms and peak value (must remain smaller than U_n)
- Voltage variation rate (dielectric losses increase with high dv/dt)
 - constraints due to ohmic losses and frequency
- Current rms and peak value
- Reactive power (estimation of loss power using $\tan\delta$)

A

T

M

S

L



Capacitor technologies

1. Applications in power inverter

1. Filter, DC-link, Snubber, clamp, resonant

2. Capacitor technologies

1. Electrochemical, ceramic, electrolytic, film foil (MKV;), metalized film (MKP, MKT)

3. Equivalent model

4. Properties and specifications

5. Aging

A

T

M

S

L



Electrochemical Double Layers Capacitors

Conventional capacitor

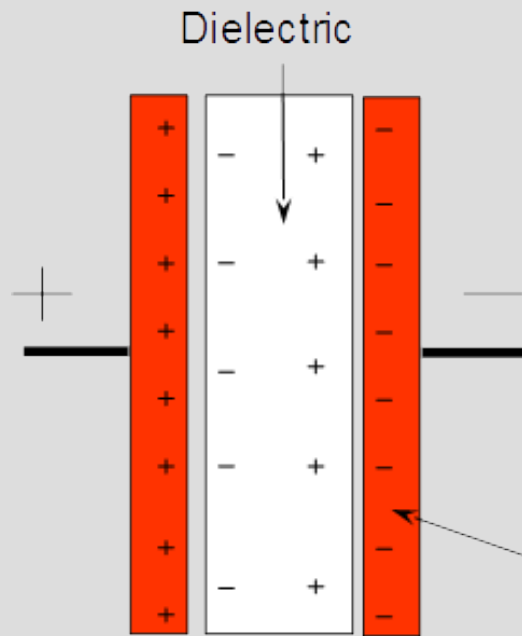

$$C = \epsilon A/d$$

$$W = 1/2 CU^2$$

$$P = U^2/4R$$

Electrodes
Current Collectors

ECDL capacitor

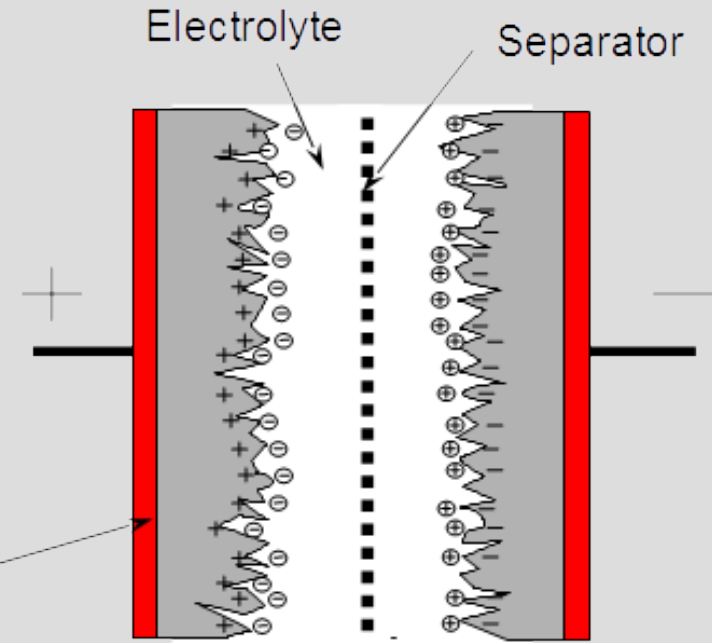

- A** up to 3000 m² (porous film)
- d** fix, ~10 Å
- ϵ_r fix, ~10
- U** 1 - 3 V, electrolyte decomposition voltage
- R** low, electrolyte

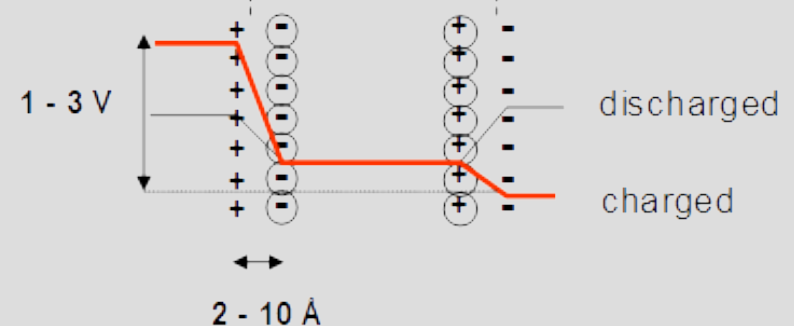

A
T
M
S
L



Electrolytic capacitors

1. Operating temperature: -55°C to 125°C
2. Polarized
3. Large tolerance +/- 20%
4. Presence of electrolyte
5. Ionic low conductivity
6. At 100 Hz and 20°C
7. High losses

$$Tg \delta = \omega r_s C = 660 \cdot 10^{-4} \quad \text{for } C = 8100 \mu\text{F}$$

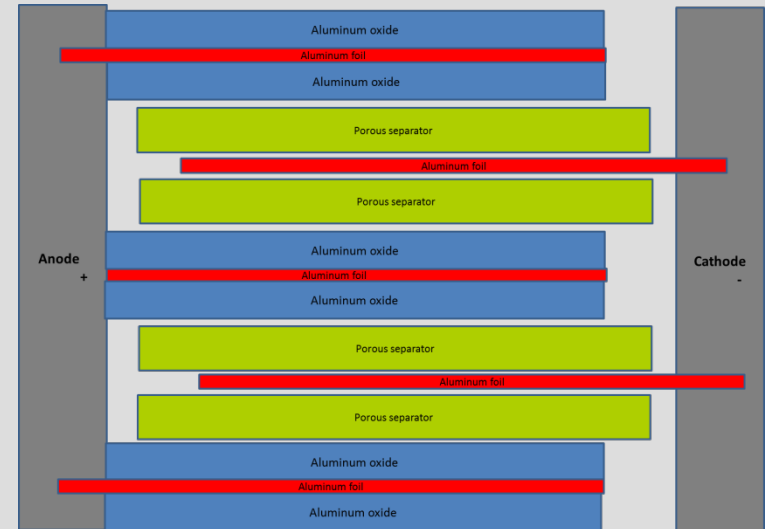

Lifetime: $U_n, I_n, 85^\circ\text{C}, 100'000$ hours
 Data from Epcos Large size EC

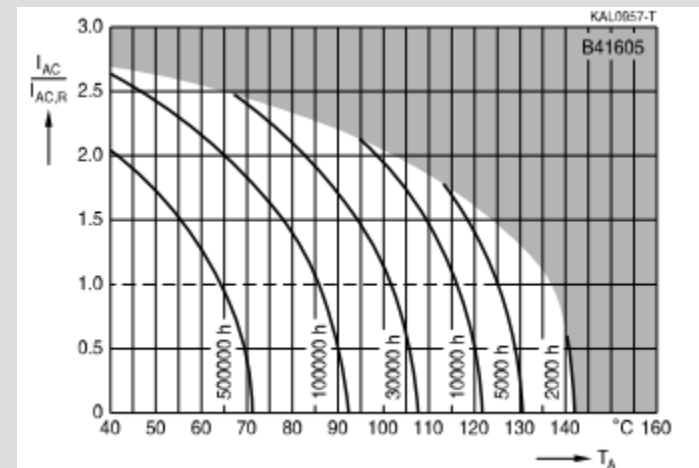

Electrolytic capacitors

1. Operating temperature: -55°C to 125°C
2. Cmax: 27 mF, 25 VDC
3. Umax: 8.1 mF, 63 Vdc
4. At 100 Hz and 20°C

$$T_g \delta = \omega r_s C = 660 \cdot 10^{-4} \quad \text{for } C = 8100 \mu\text{F}$$

C_R 100 Hz 20 °C μF	Case dimensions $d \times l$ mm	ESR_{max} 100 Hz 20 °C m Ω	ESR_{max} 100 Hz -40 °C m Ω	ESR_{max} 10 kHz 20 °C m Ω	$I_{\text{AC,max}}$ 10 kHz 125 °C A	$I_{\text{AC,R}}$ 10 kHz 125 °C A
$V_R = 63 \text{ V DC}$						
2000	22 x 40	35	115	19	9.5	6.4
2700	25 x 40	26	85	15	10.4	7.0
3900	25 x 50	20	65	12	13.2	9.0
5600	30 x 50	16	45	11	14.3	9.8
8100	35 x 50	13	35	11	14.6	10.0

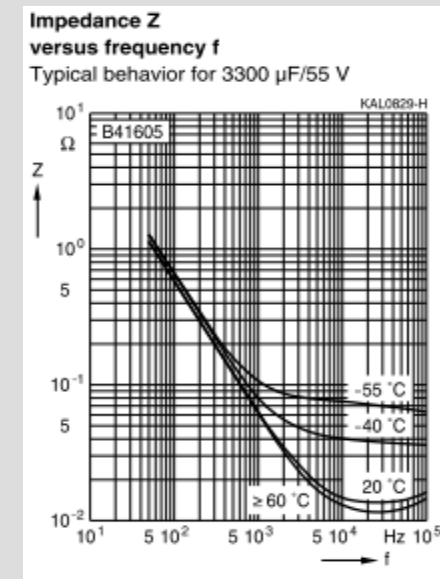
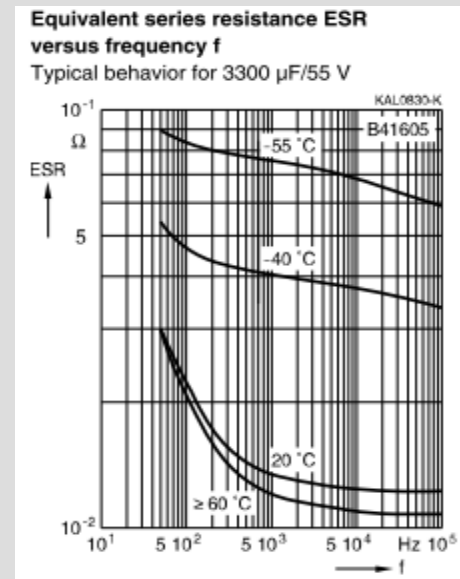
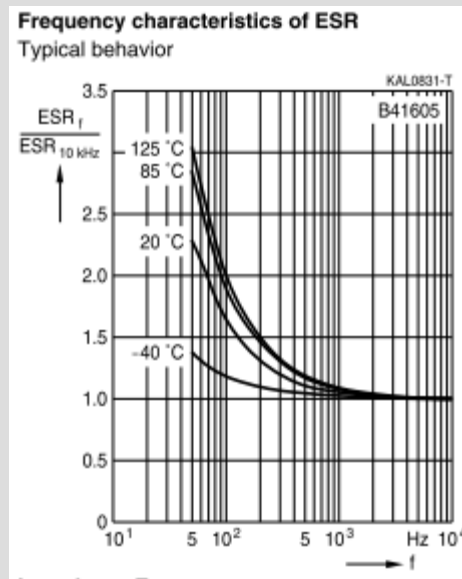
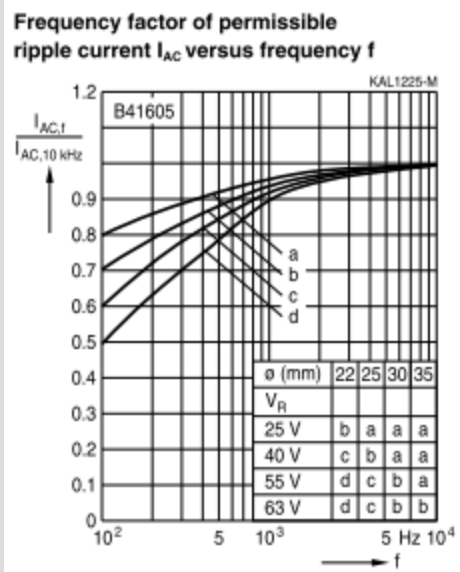

Data from Epcos Large size EC

Electrolytic capacitors



A
T
M
S
L

Operating Temperature Range		-40°C to +85°C (10VDC to 250VDC) -25°C to +85°C (350VDC to 500VDC)															
Capacitance Tolerance		+20% at 120 Hz, 20°C															
Surge Voltage	WVDC	10	16	25	35	50	63	80	100	160	200	250	350	400	450	500	
	SVDC	13	20	32	44	63	79	100	120	200	250	300	400	450	500	550	
Dissipation Factor (120 Hz)	WVDC	10	16	25	35	50	63	80	100	160	200	250	350	400	450	500	
	tan δ	.55	.5	.45	.4	.35	.3	.25	.2	.15	.15	.15	.15	.15	.2	.2	
		For capacitance values above 33000µF add the following to the Dissipation factors values above $(\frac{\text{capacitance}-33000 \mu\text{F}}{10000 \mu\text{F}}) \times 0.1$															
Leakage Current @20°C, Rated WVDC applied		Time	5 Minutes														
		3√CV															
Impedance Ratio (120 Hz)	WVDC	10	16	25	35	50	63	80	100	160	200	250	350	400	450	500	
	-25°C/+20°C	4	4	4	4	4	4	4	4	3	3	3	3	8	8	8	
	-40°C/+20°C	15	15	15	15	15	15	15	15	15	15	15	-	-	-	-	
Load Life	2000 hours with rated voltage applied at 85°C with full rated ripple current applied																
	Capacitance Change	≤20% of initial measured value															
	Dissipation Factor	≤200% of maximum specified value															
	Leakage Current	≤100% of maximum specified value															
Shelf Life	1000 hours at 85°C with no voltage applied																
	Capacitance Change	≤20% of initial measured value															
	Dissipation Factor	≤200% of maximum specified value															
	Leakage Current	≤100% of maximum specified value															
Ripple Current Multipliers	Frequency (Hz)																
	WVDC	60	120	1k	10k												
	10 to 100	0.9	1.0	1.15	1.25												
	160 to 250	0.8	1.0	1.15	1.47												
	350 to 500	0.8	1.0	1.15	1.47												

Data from Illinois LBA 47 to 47'000 µF



Ceramic capacitor

Data from AVX

Parameter/Test	X5R Specification Limits	Measuring Conditions
Operating Temperature Range	-55°C to +85°C	Temperature Cycle Chamber
Capacitance	Within specified tolerance	Freq.: 1.0 kHz \pm 10% Voltage: 1.0Vrms \pm .2V For Cap > 10 μ F, 0.5Vrms @ 120Hz
Dissipation Factor	\leq 2.5% for \geq 50V DC rating \leq 3.0% for 25V DC rating \leq 12.5% Max. for 16V DC rating and lower Contact Factory for DF by PN	
Insulation Resistance	10,000M Ω or 500M Ω - μ F, whichever is less	Charge device with rated voltage for 120 \pm 5 secs @ room temp/humidity
Dielectric Strength	No breakdown or visual defects	Charge device with 300% of rated voltage for 1-5 seconds, w/charge and discharge current limited to 50 mA (max)

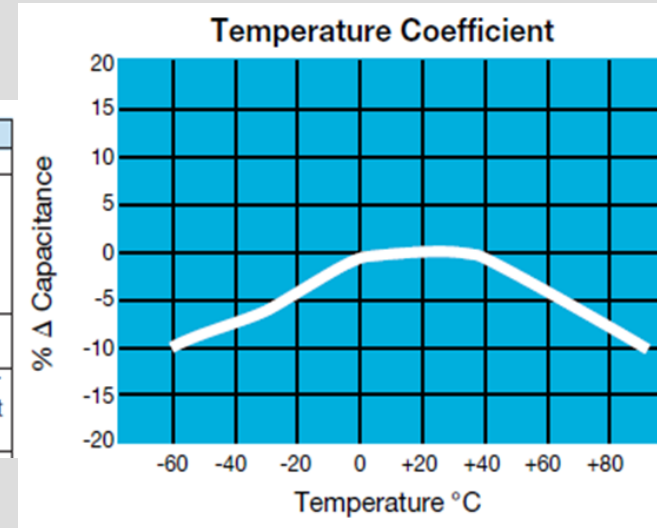

Data from Epcos CeraLink (Antiferroelectric)

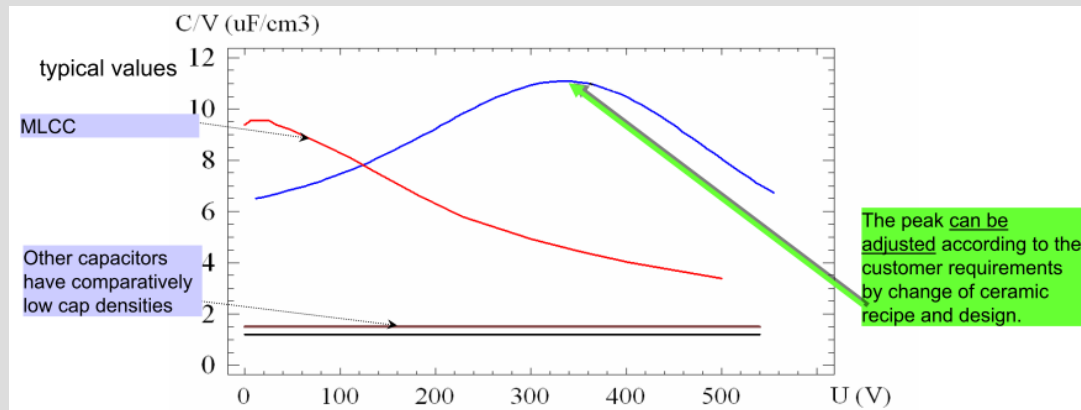

Ceramic capacitor

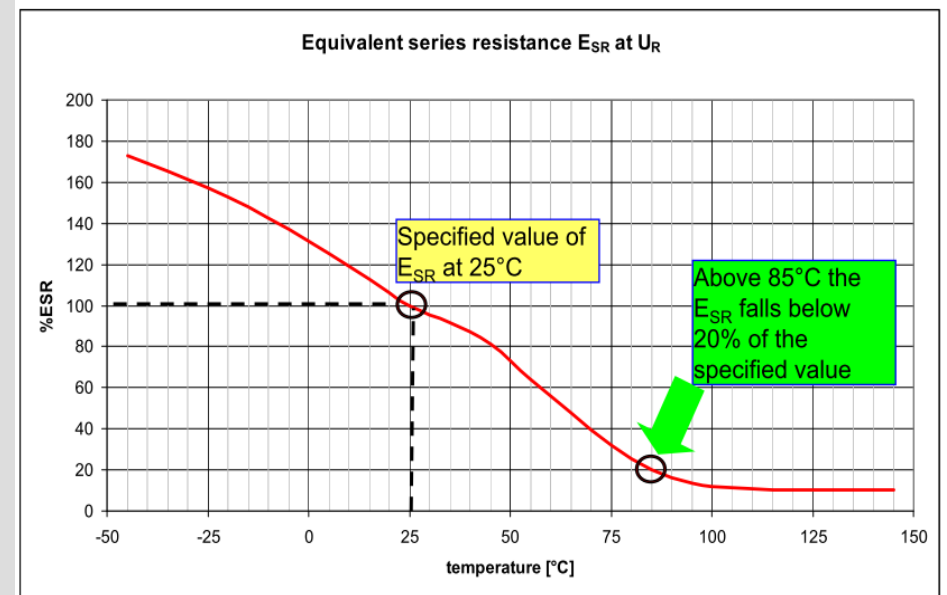
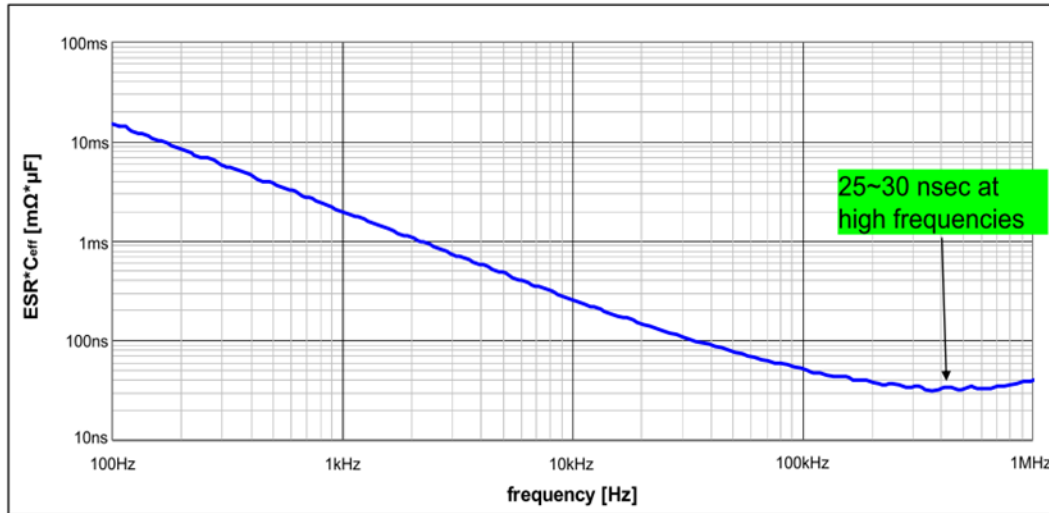

Data from Epcos

A
T
M
S
L



Film foil capacitors

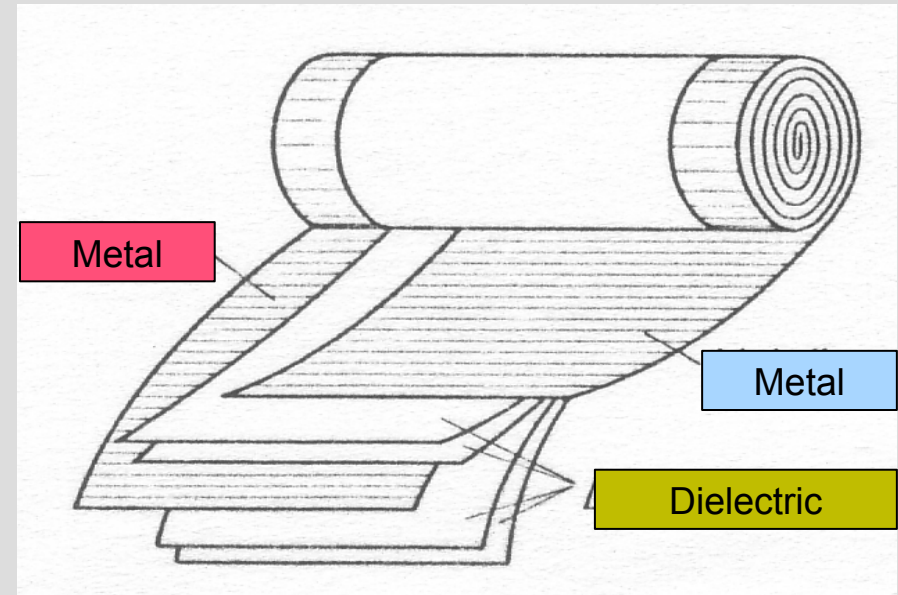
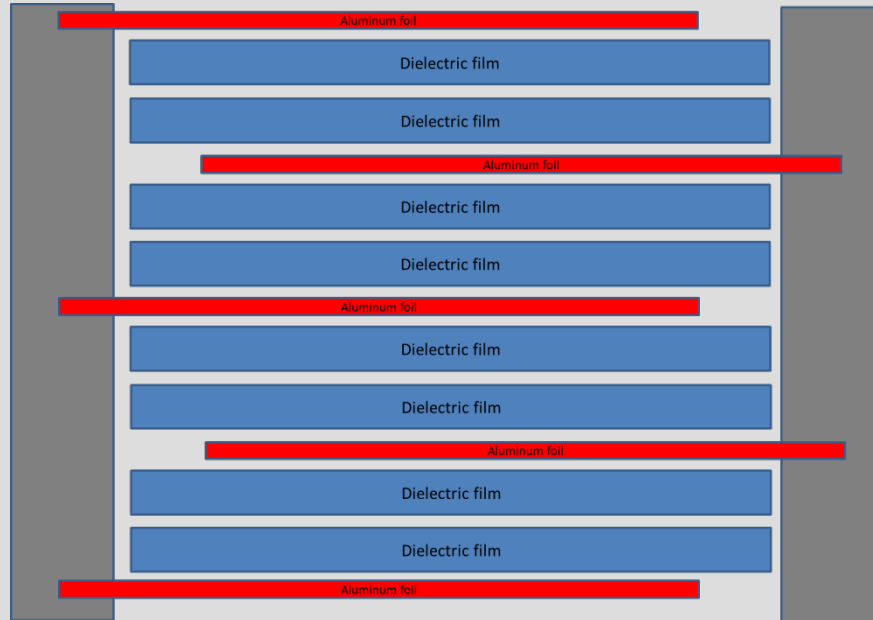

- Typical 5 μm Aluminum foil + multi-layer of PP and/or PA and/or PET films
- Oil impregnation
- Very low losses
- In DC must be protected with fuses



A
T
M
S
L



Metalized film capacitors

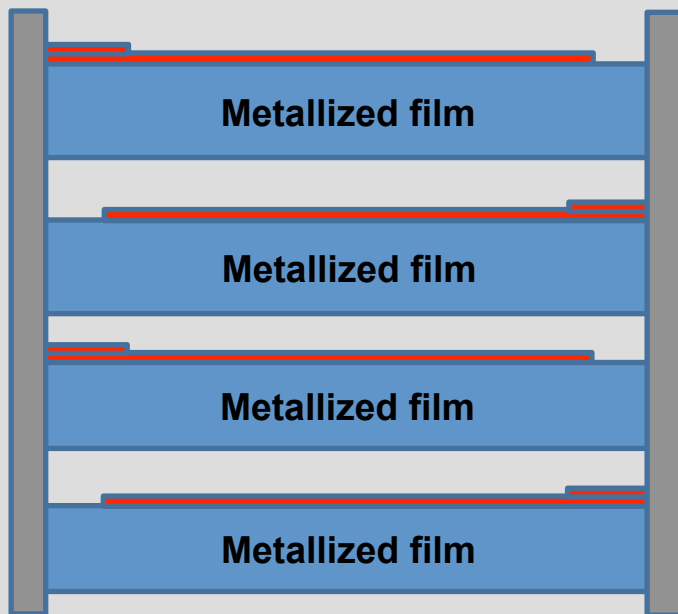

- Dielectric film with a 100 nm layer of metalization deposited on the surface
- Metalization of Zn, Al or Zn-Al
- Heavy edge to increase the contacting
- Segmentation or profile of the metalization to improve the safety
- Oil, gas or dried execution

Selfhealing: capability of disconnecting area around a breakdown. The metalization is evaporated by the shortening current until the available energy is big enough.

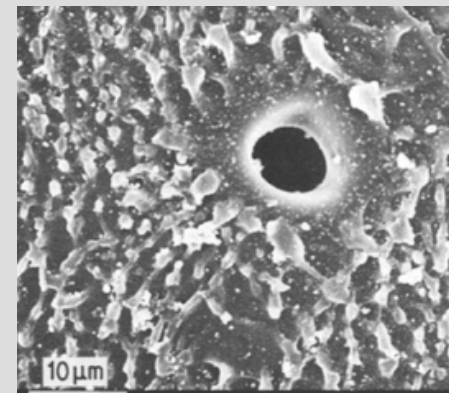

A

T

M

S

L



Metalized film capacitors

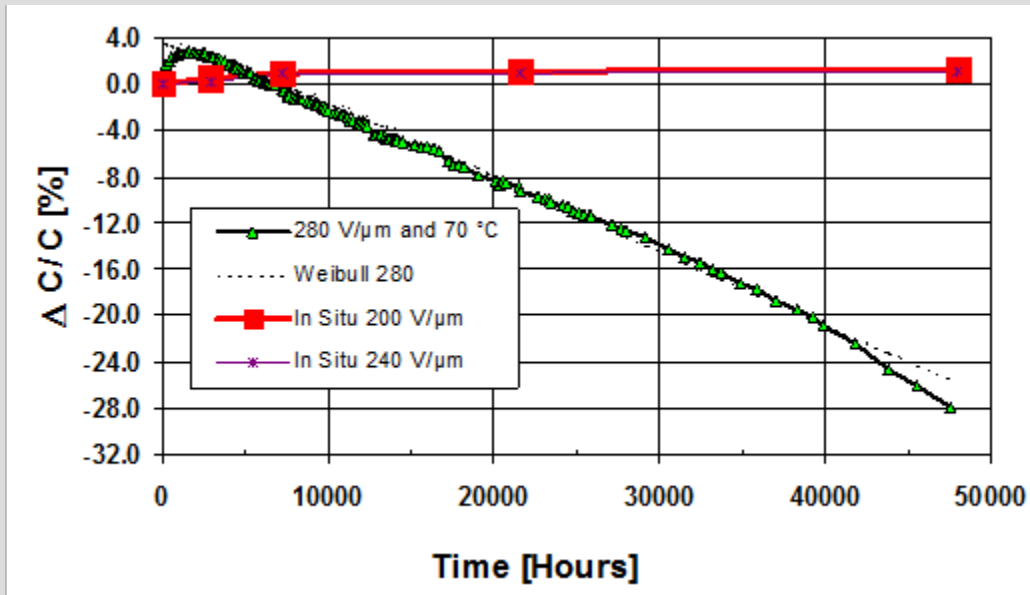

- TGV input filter 1800 V, 8 mF
- Capacitance loss
- Metalized film

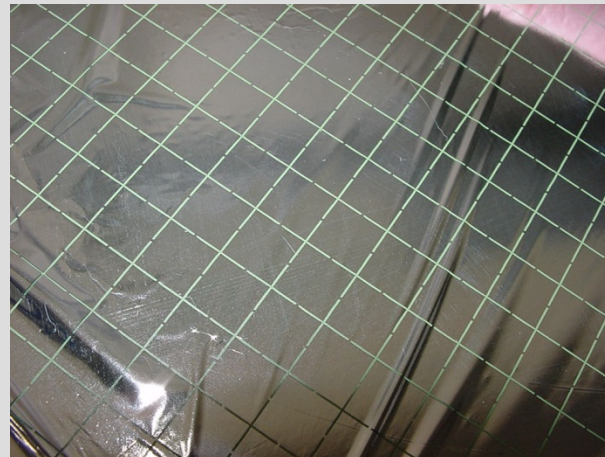

A

T

M

S

L



Comparison

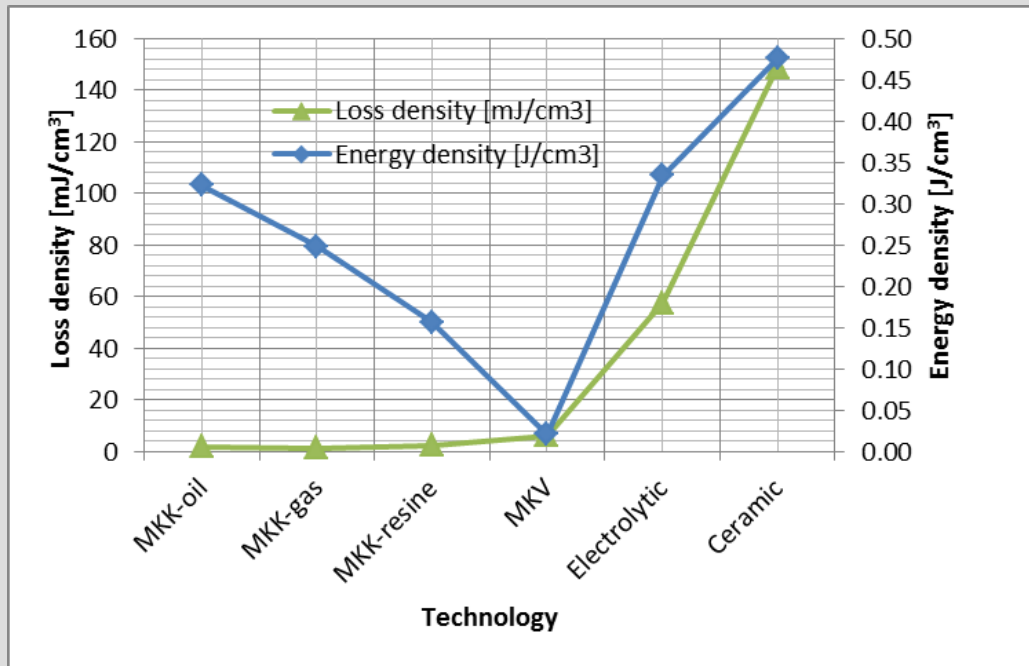

	Energy density [J/cm³]	Current density [A/cm³]	Loss density [mJ/cm³]	Voltage [Vdc]	Current [A]	C [mF]	Rs [mOhm]	Tg [1]	Tmax [°C] /L [H]	Volume [cm³]	Réf
MKK-oil	0.32	0.009	1.8	2700	320	3	0.6	0.0002	75 / 150'000	33941	B25750H1698K004
MKK-gas	0.25	0.006	1.3	4000	290	1.4	0.7	0.0001	75 / 150'000	45161	B25650H4148K004
MKK-resine	0.16	0.014	2.4	800	350	12.5	0.5	0.0001	70 / 100000	25500	B25640D8129K000
MKV	0.02	0.052	6.2	4000	80	0.004	1.5	0.0002		1539	B25856K2405K003
Electrolytic	0.33	0.303	57.6	63	14.6	8.1	13	0.6	125 / 2000	48	B41605B8818M00
Ceramic	0.48	0.119	23.8	400	2	0.1	100	0.1		85	CeraLink PFBB 17 Hyp: 2 A

A
T
M
S
L



Domain

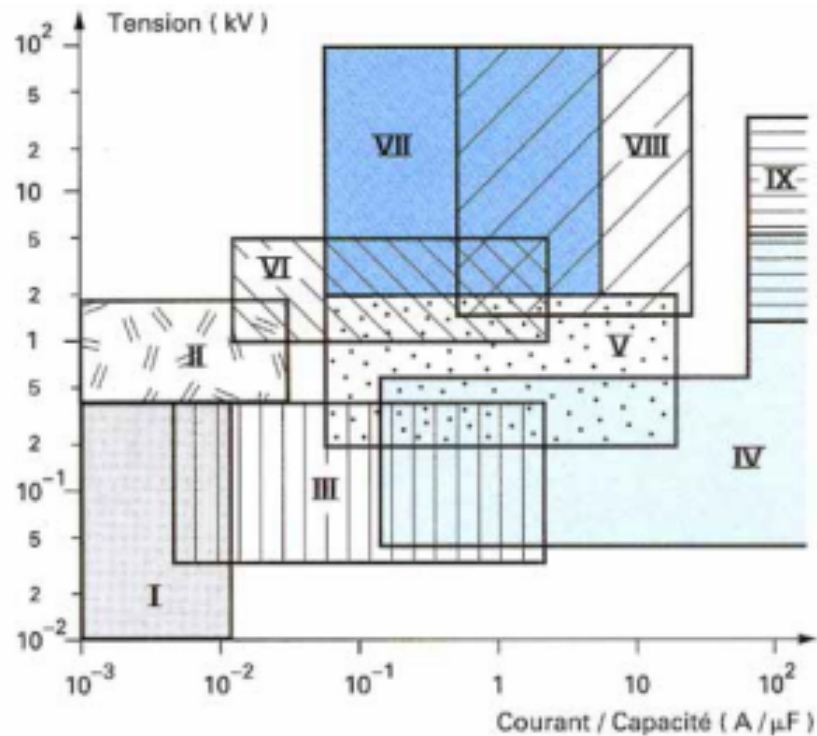

- I** condensateur électrolytique (§ 2.6)
- II** condensateur électrolytique par montage série-parallèle (§ 2.6)
- III** condensateur film polyester, métallisé sec (§ 2.52)
- IV** condensateur céramique multicouche, sec (§ 2.1)
- V** condensateur au polypropylène, métallisé sec (§ 2.512)
- VI** condensateur au polypropylène, métallisé imprégné (§ 2.512) et condensateur au papier métallisé imprégné (§ 2.42)
- VII** condensateur au papier avec armature, imprégné (§ 2.41)
- VIII** condensateur mixte (papier et film), imprégné (§ 2.51)
- IX** condensateur céramique HT , sec (§ 2.1)

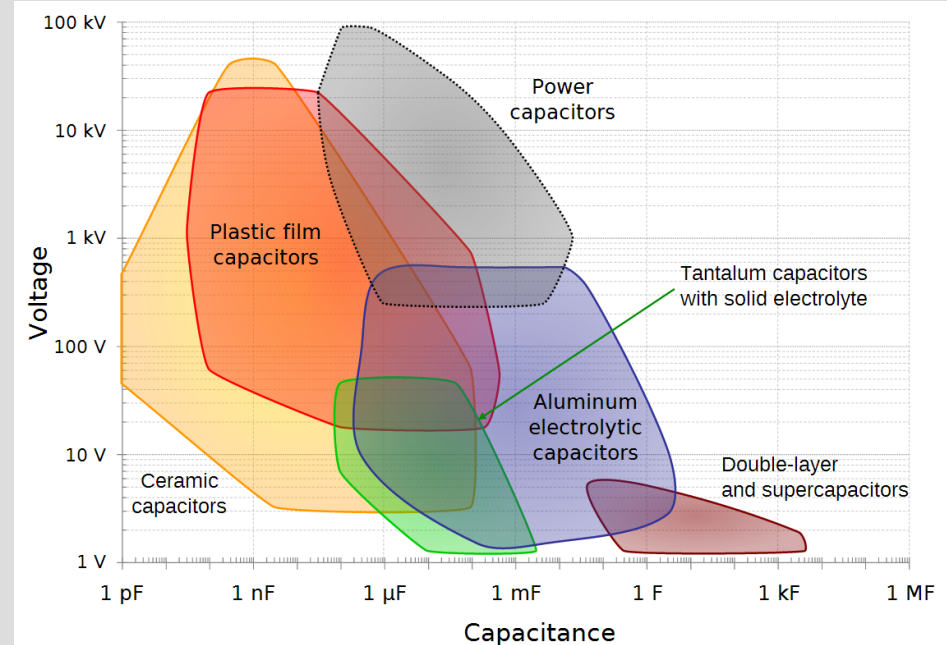

<http://upload.wikimedia.org/wikipedia/commons/9/93/Kondensatoren-Kap-Versus-Spg-English.svg>

Capacitor construction

Parallel connection

- High power

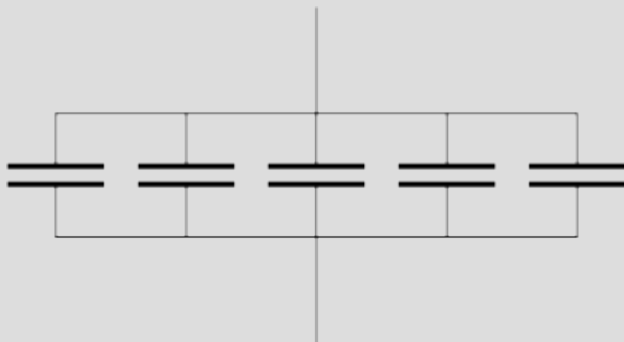

Series connection

- High voltage



A

T

M

S

L



Equivalent model

1. Applications in power inverter

1. Snubber, clamp, resonant, DC-link

2. Capacitor technologies

1. Electrochemical, electrolytic, film foil, metalized film

3. Equivalent model

4. Properties and specifications

5. Ageing

A

T

M

S

L



Equivalent model

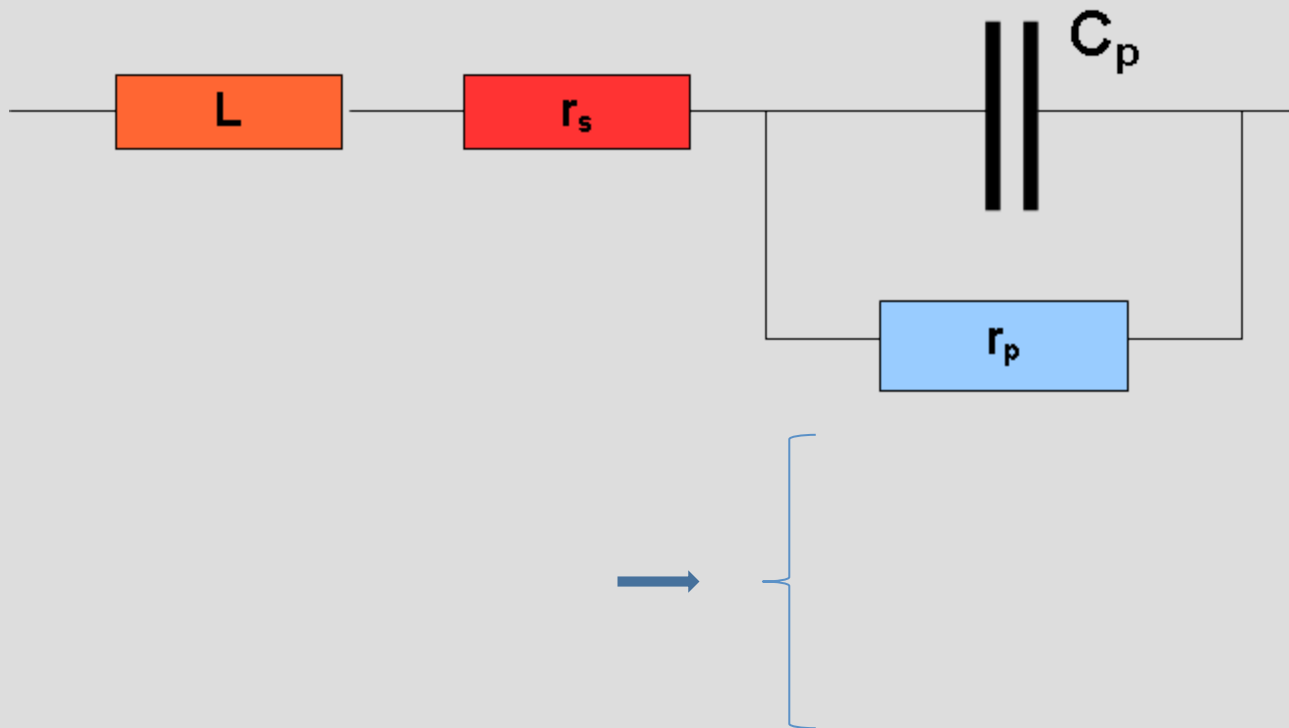

- A
- T
- M
- S
- L



Power losses: Tangent delta

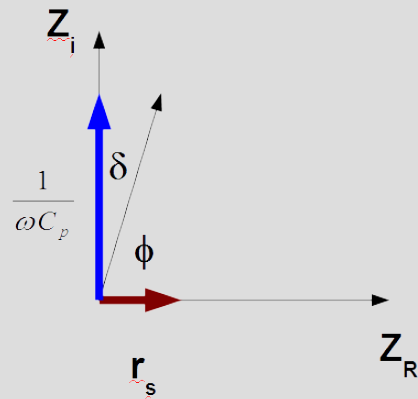

$$\tan \delta = \frac{P_D}{P_R}$$

$$i = \frac{dQ}{dt} = C_p \frac{dU}{dt} = \omega C_p U_o \cos \omega t$$

$$P_D = \frac{1}{T} \int_0^T r_s i^2(t) dt$$

A

T

M

S

L



Simplified models

$$\tan \delta = \tan \delta_s + \tan \delta_\varepsilon + \tan \delta_p$$

Series model

$$R_p = \infty$$

$$L = 0$$

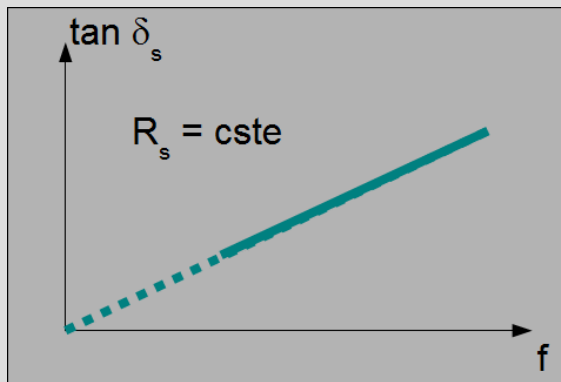
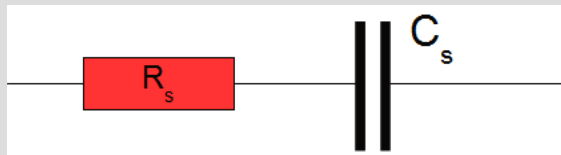

$$\tan \delta_s = \frac{Z_R}{Z_i} = R_s \omega C_s$$

Parallel model

$$R_s \rightarrow 0$$

$$L = 0$$

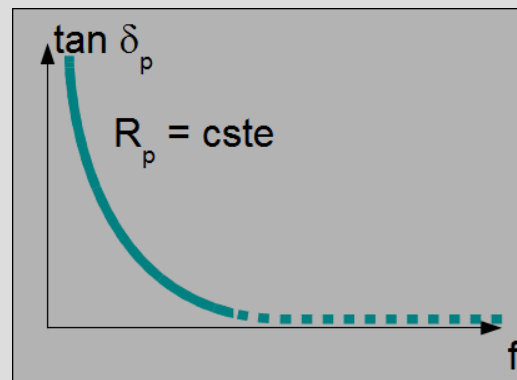
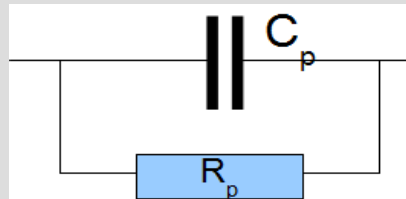

$$\tan \delta_p = \frac{Z_R}{Z_i} = \frac{1}{R_p \omega C_p}$$

R_p includes

- dielectric losses
- leakage current

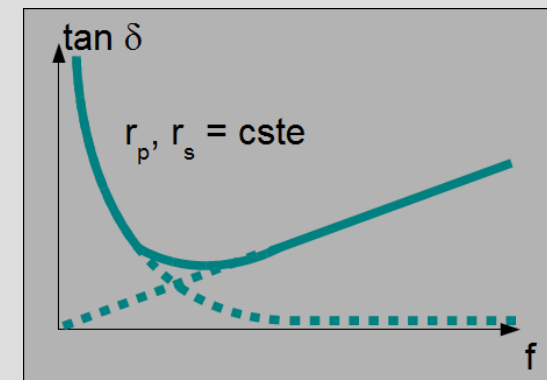

A
T
M
S
L



Properties and specifications

1. Applications in power inverter

1. Snubber, clamp, resonant, DC-link

2. Capacitor technologies

1. Electrochemical, electrolytic, film foil, metalized film

3. Equivalent model

4. Properties and specifications

5. Ageing

A

T

M

S

L



Dielectric characteristics

Material	Dielectric constant [1]	Tangent δ [E-4]	Dielectric strength [V μ m]	Volumetric resistivity [Ω cm]	Surface resistivity [Ω]	Creeping resistance	Flammability (UL-94)	Max Oper. Temp [°C]
PP	2.2	5	640	10 ¹⁸	5 10 ¹³			105
PET	3.3	25	570	10 ¹⁷	10 ¹⁴	CTI225	VTM-2	125
PEN	2.9	20	600	10 ¹⁷			VTM-2	137
PPS	2.9	10	300	10 ¹⁶	10 ¹⁷	CTI100	VTM-0	200

A
T
M
S
L



Polypropylene temperature characteristics

- Variation Epsi (T)
- Variation Tg (T)
- Insulation resistance

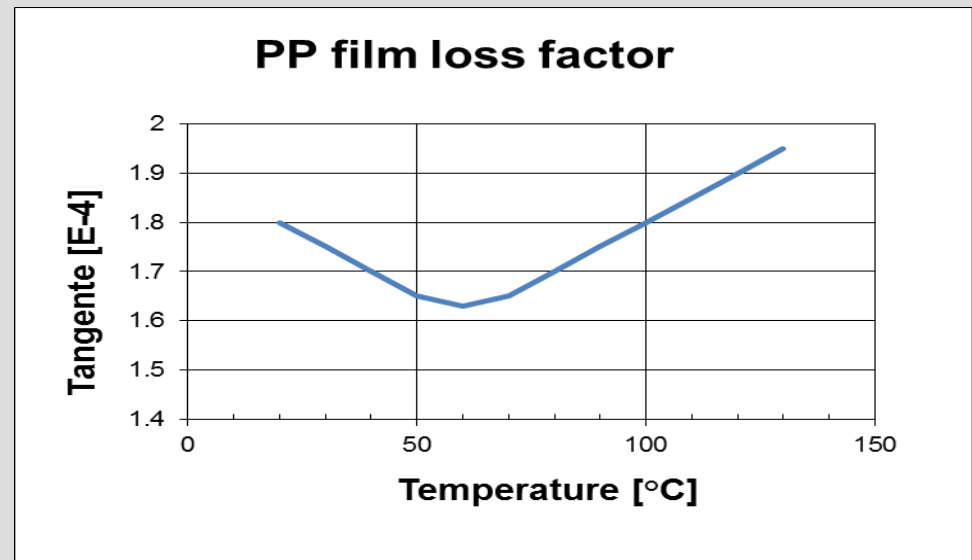
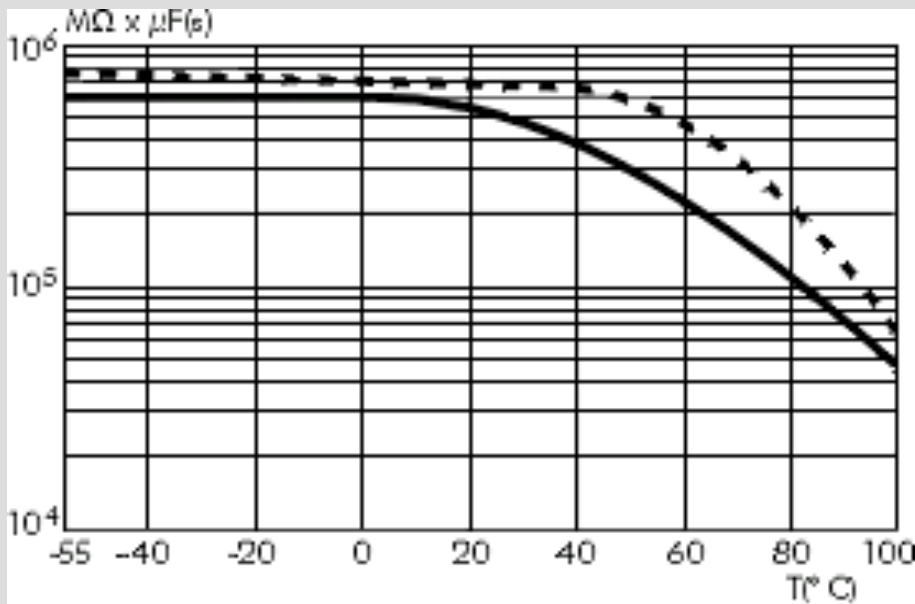
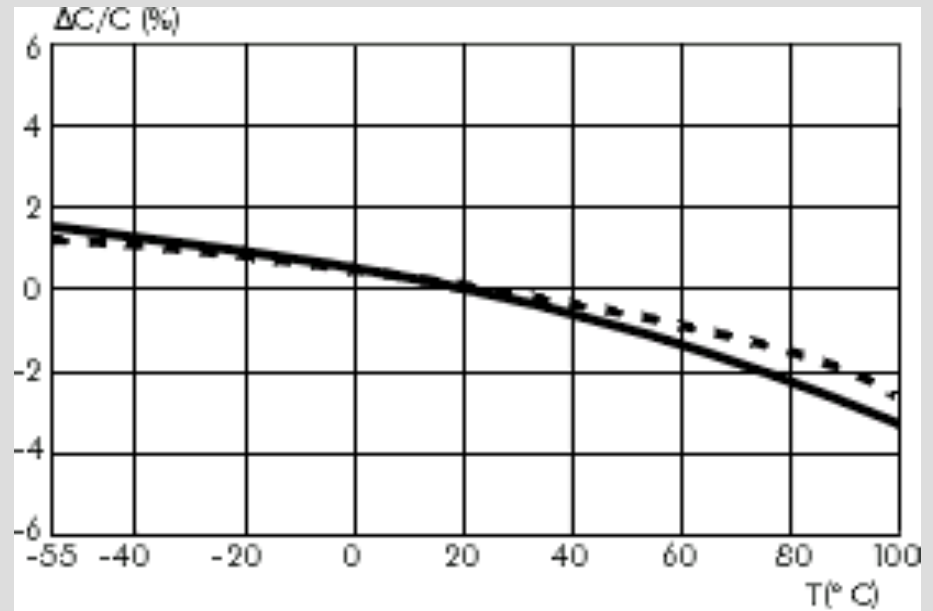

A

T

M

S

L

PET dielectric strength

- Dielectric strength as a function of:
 - the film thickness
 - Temperature
 - humidity

Figure 1. Dielectric Strength vs. Thickness
(2 in Electrode in air at 25°C [77°F])

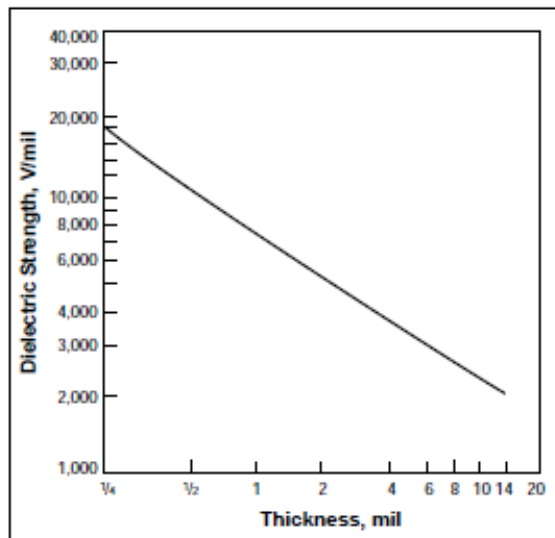

Figure 2. Dielectric Strength vs. Temperature

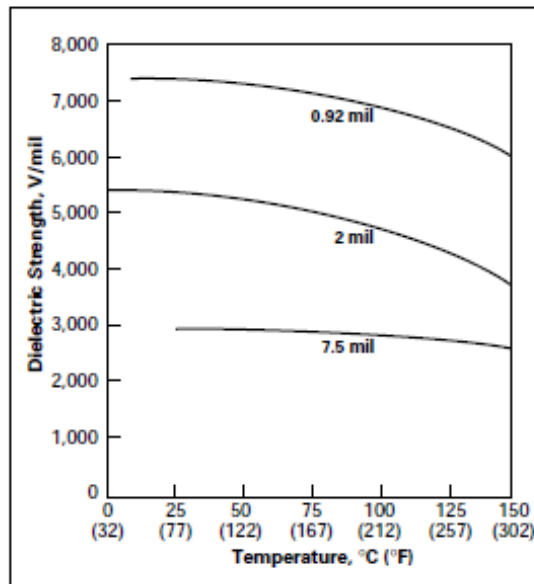
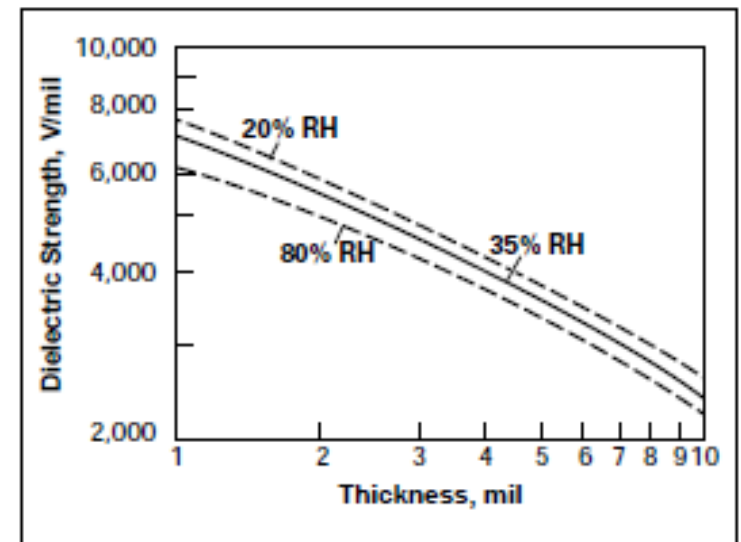
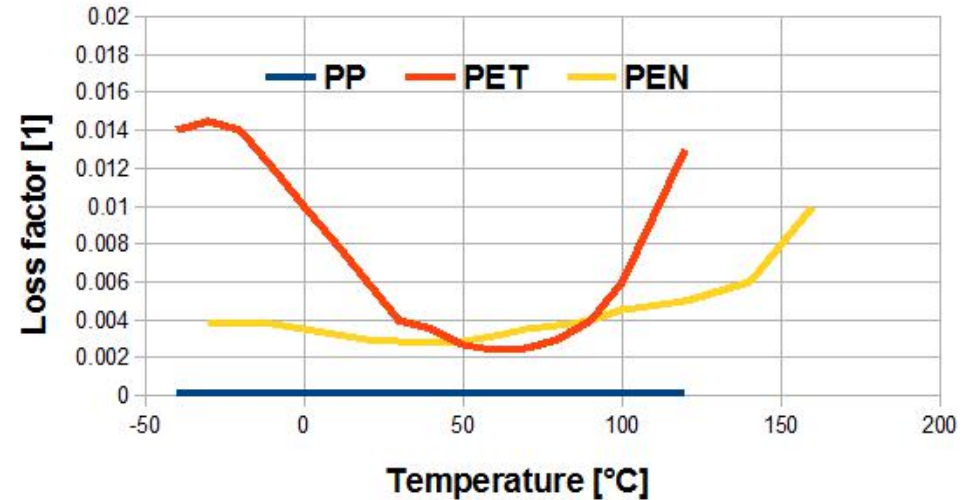
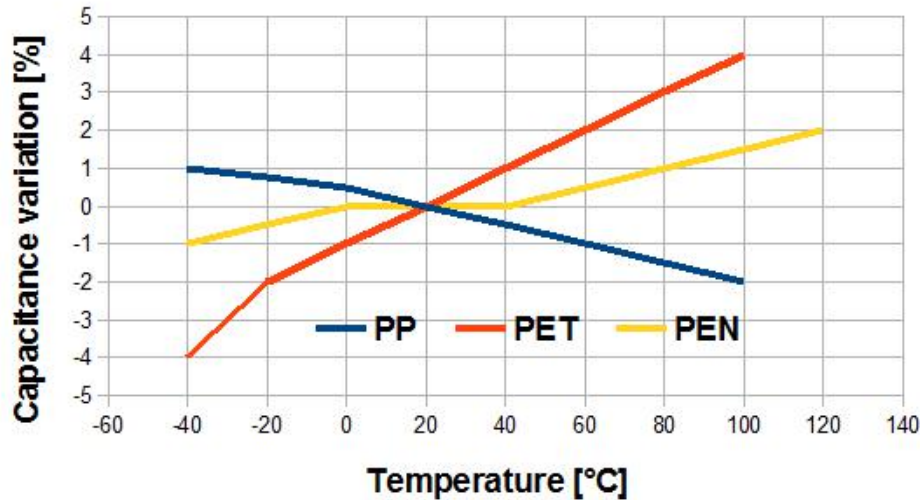

Figure 3. Dielectric Strength at Various Humidities



Dielectric temperature dependence



- Variation C and tg (T) main dielectric used for capacitors

A

T

M

S

L



Dielectric frequency dependence AC-DC

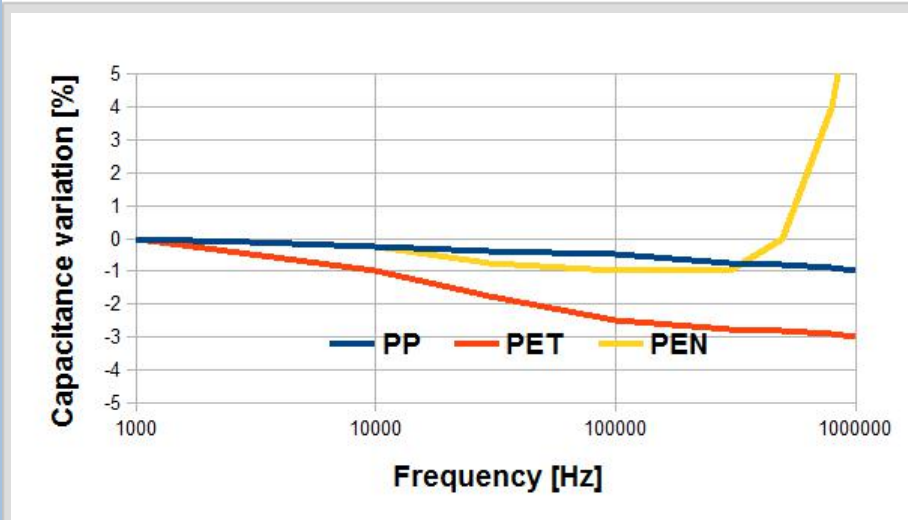

- Variation C and tg (f)

A

T

M

S

L



Electric field

Dry



$$E = U / d = 180 \text{ V}/\mu\text{m}$$

Impregnated



$$E = U / (d+h) = 180 \text{ V}/\mu\text{m}$$

$$E_c = U / d = 200 \text{ V}/\mu\text{m}$$

A

T

M

S

L



Polypropylene PP

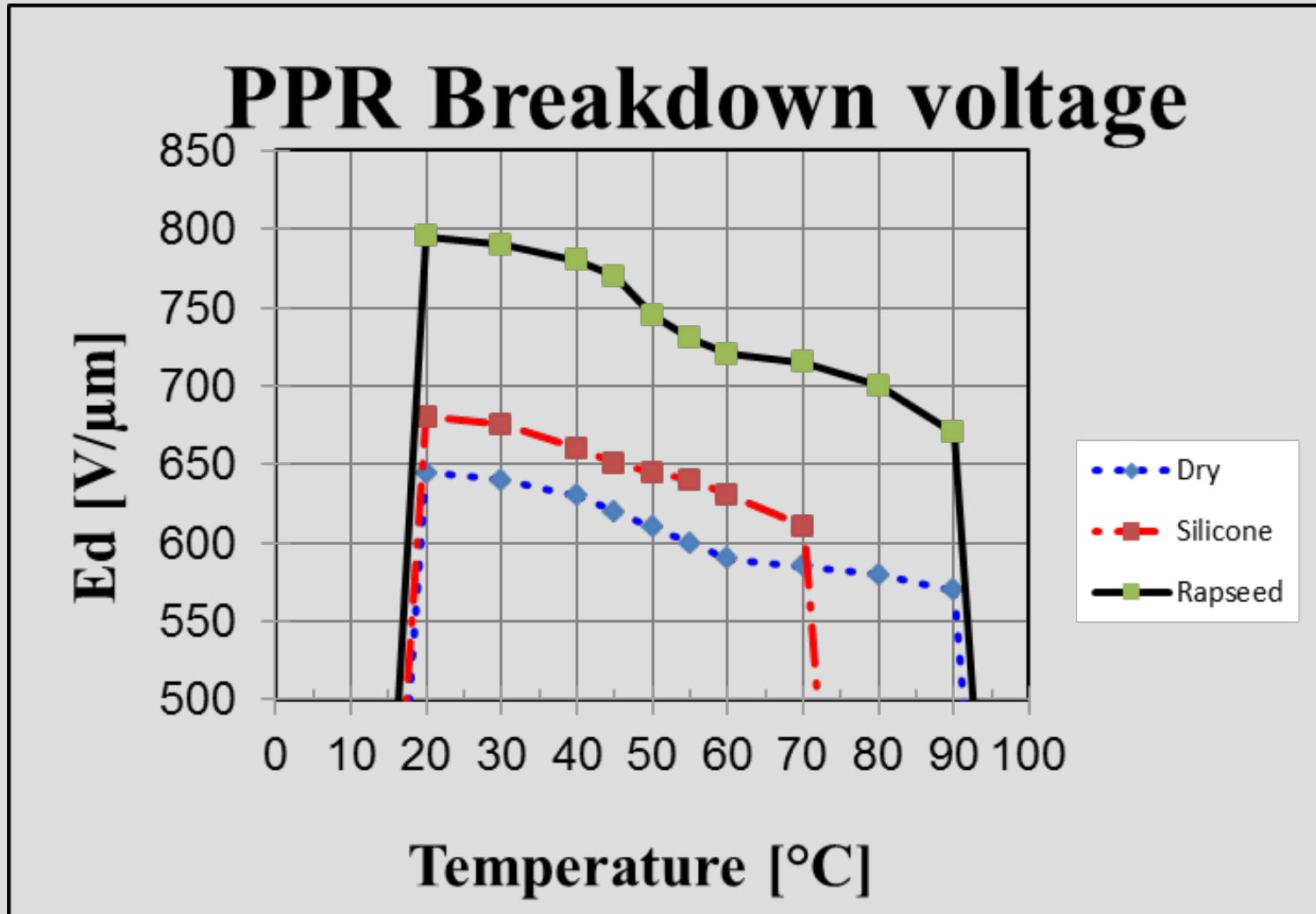

A
T
M
S
L



AC limitation as a function of the frequency

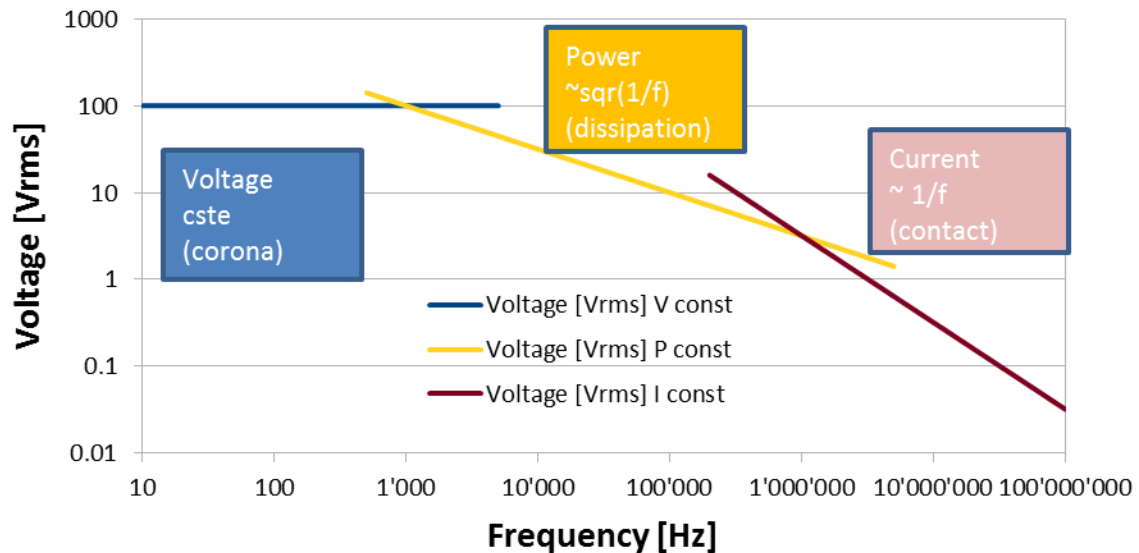

$$U = Zi = \frac{i}{\omega CR_s}$$

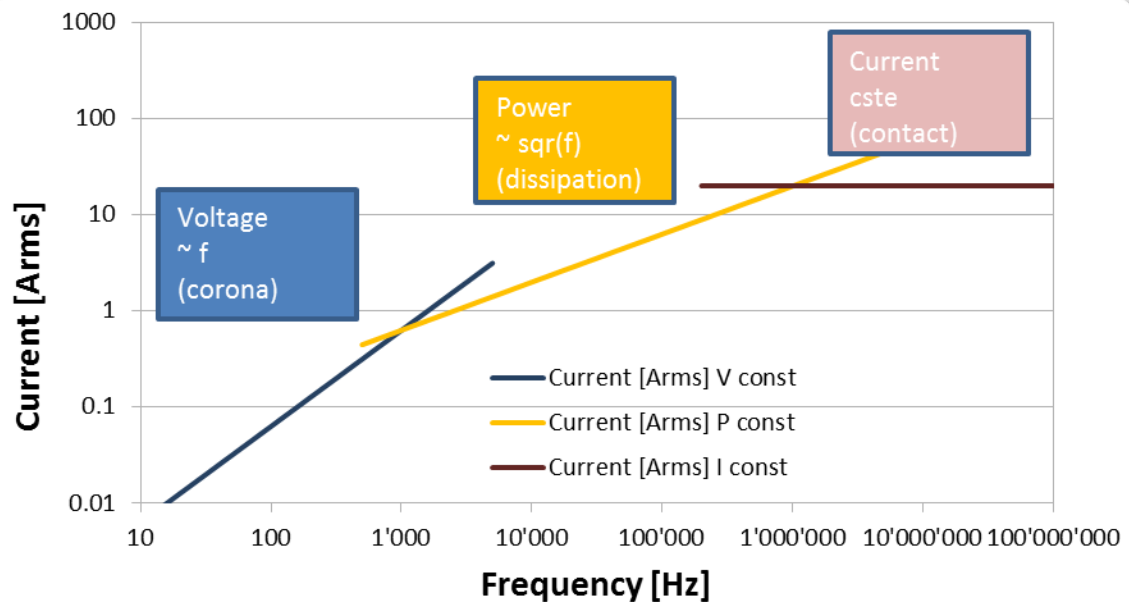

Ageing

1. Applications in power inverter

1. Snubber, clamp, resonant, DC-link

2. Capacitor technologies

1. Electrochemical, electrolytic, film foil, metalized film

3. Equivalent model

4. Properties and specifications

5. Ageing

A

T

M

S

L



Weibull distribution

Survivor function

The Survivor function $F(t)$ is the number of elements of the statistical sample which have not failed or lost their function at time t and are still working.

$$\lambda_o = 1'500'000 \text{ hours}$$
$$p = 1.8$$

Failure rate

The failure rate is given in FIT (Failure In Time) which is the number of failures occurring during 10^9 hours of working of 1 object. λ_o is a constant (independent of time, but dependent on the temperature and voltage) which corresponds to the inverse of the time necessary for 63 % of the sample to fail.

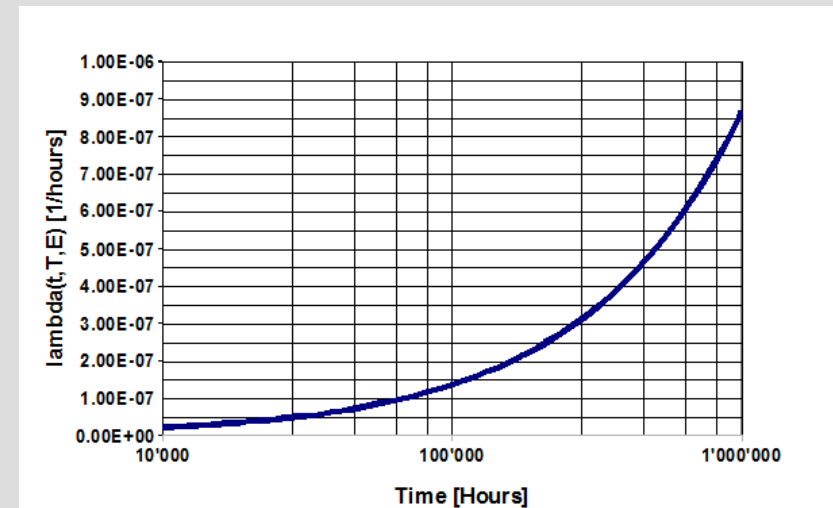
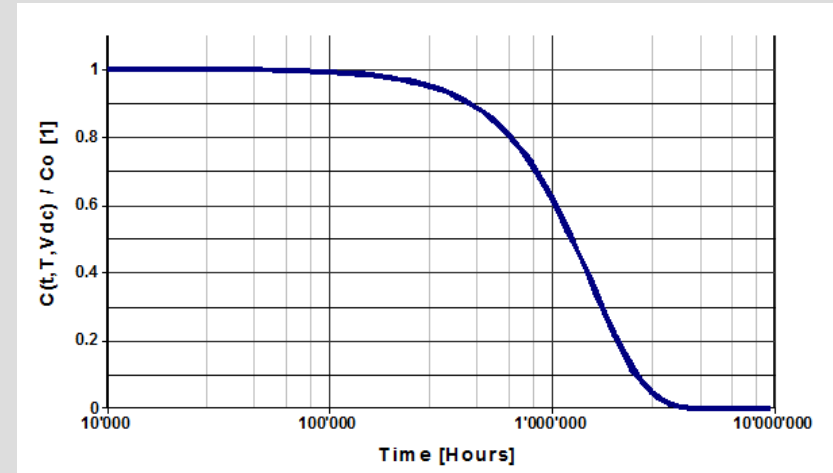

Example

Initial batch of 50 capacitor samples

The Failure in % is represented in a Weibull graphic which is a $\text{Log}(\text{Log}(1/F(t)))$ function as a function of $\text{Log}(t)$.

t [s]	N * F(t)	Log(Log(1/F(t)))
1	50	-9.0037887
113	49	-2.0568061
149	48	-1.7513214
184	47	-1.5706976
187	46	-1.4411454
200	45	-1.3395378
209	44	-1.2555714
219	43	-1.1837484
242	42	-1.1207853
256	41	-1.0645625

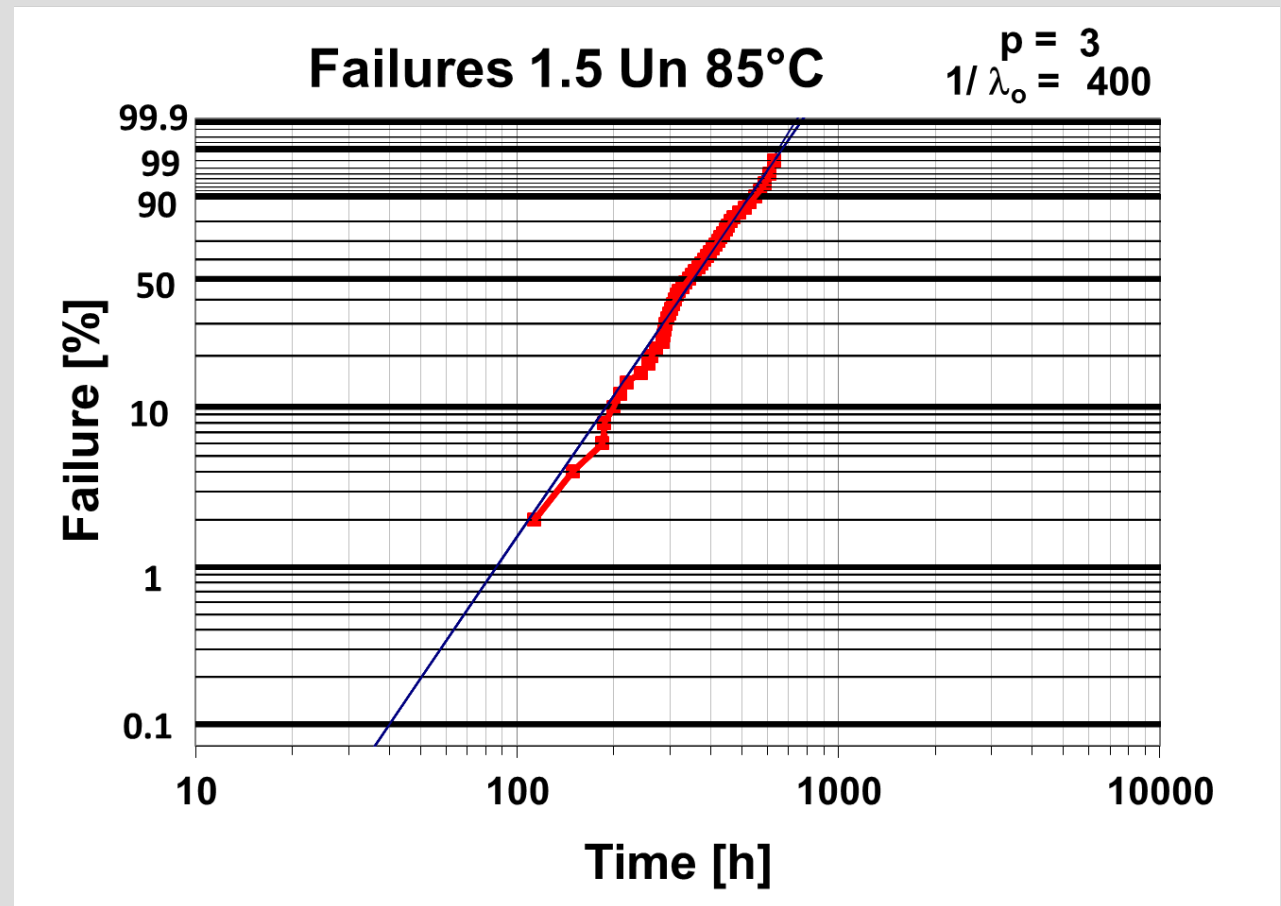

A

T

M

S

L



Acceleration factor: temperature

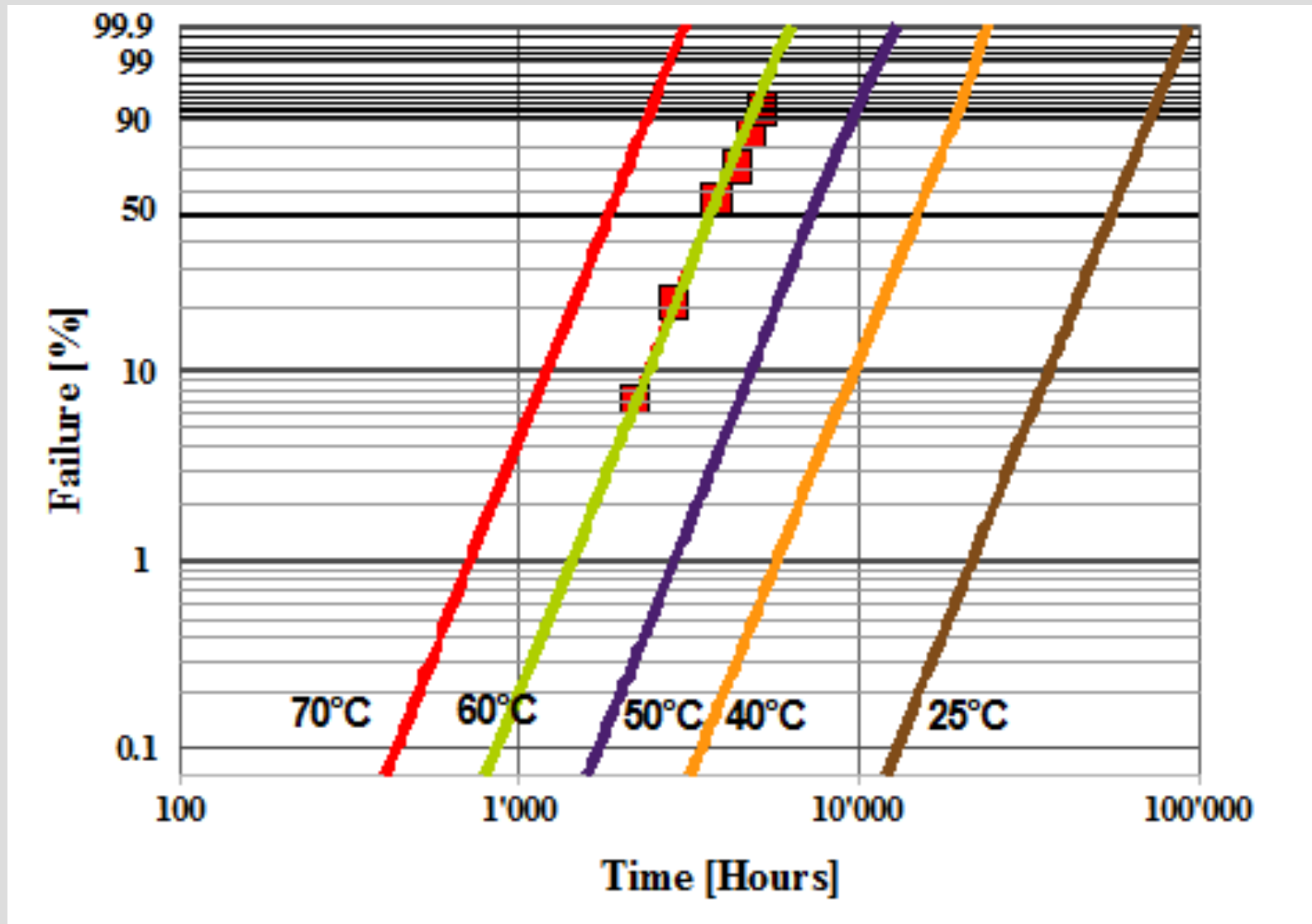

A
T
M
S
L



Acceleration factors: temperature, humidity

- Temperature

$$t(T) = t_{Tn} \exp\left(\frac{E_a}{k_B} \left(\frac{1}{T} - \frac{1}{T_n}\right)\right)$$

Exponential law
(Arrhenius law)

- Humidity

$$t(RH) = t_{RHn} \left(\frac{RH_n}{RH}\right)^m$$

Power law
(Hallberg-Peck law)

A

T

M

S

L



Acceleration factors: voltage

- Voltage inverse power law

$$t = t_{un} \left(\frac{U}{U_n} \right)^{-n}$$

n = 15

- Voltage exponential law

$$t = t_{un} \exp \left(-\alpha \frac{(U - U_n)}{U_n} \right)$$

$\alpha = 15$



Temperature and voltage derating

Lifetime expectancy – typical curve

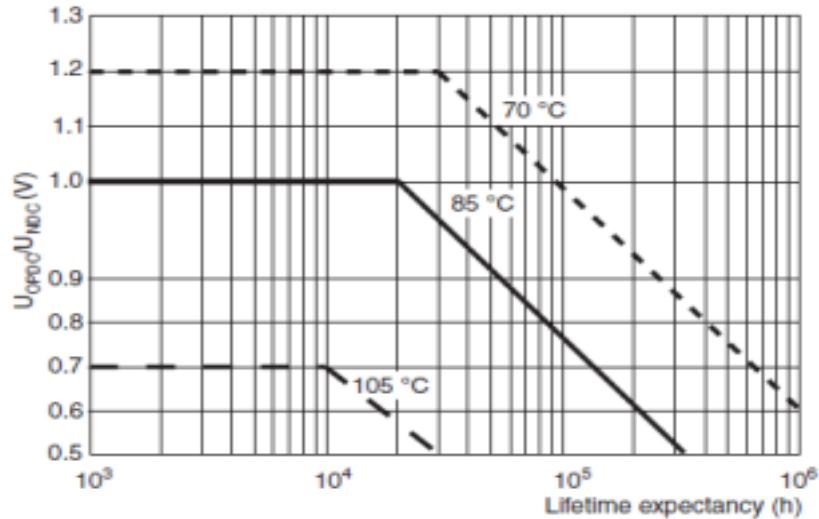

Life expectancy (typical curve)

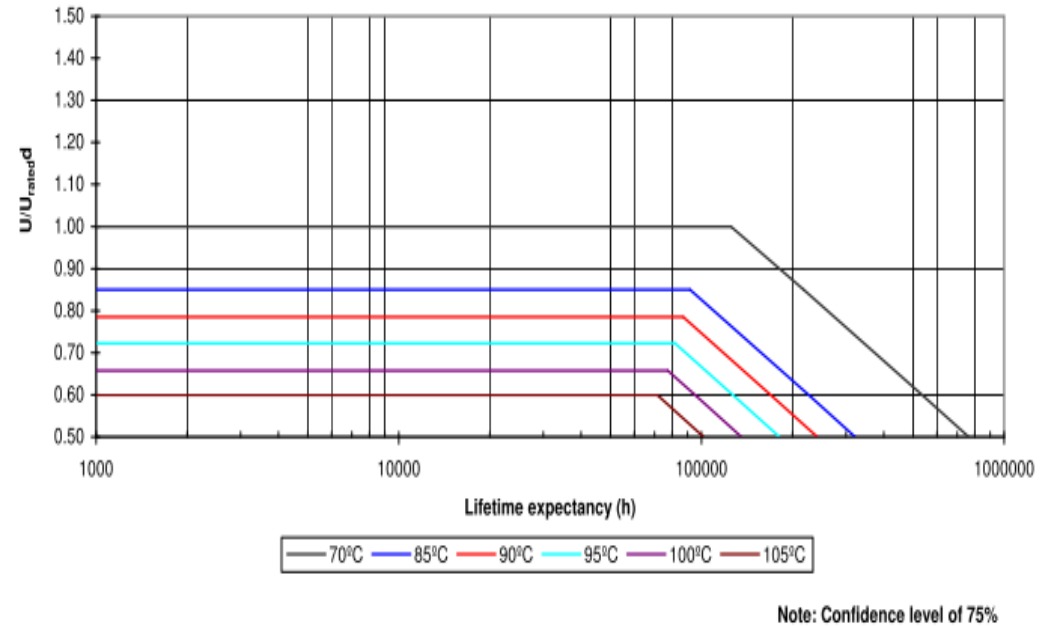

- Vishay MKP

- Epcos-TDK MKP

A
T
M
S
L

Acceleration factor: voltage

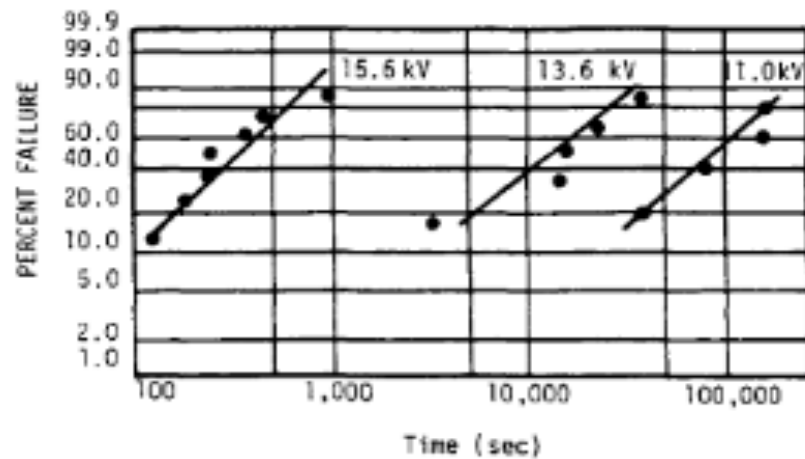

Figure 3.

Weibull plots for times to breakdown under dc stress at 23°C.

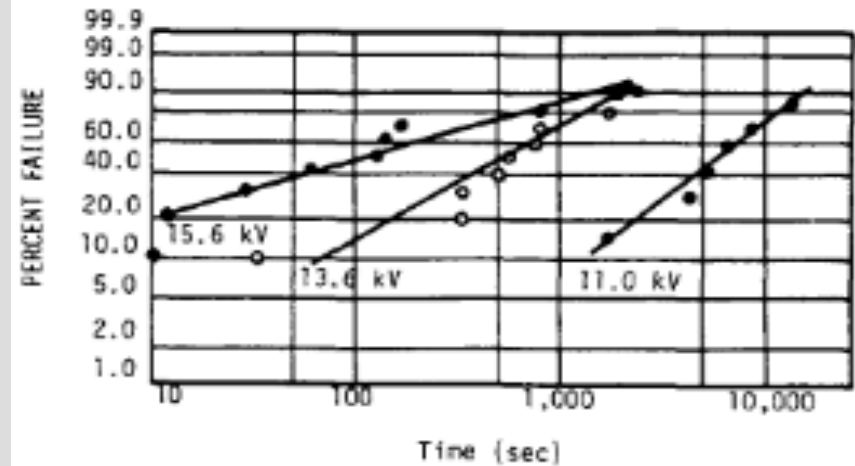

Figure 4.

Weibull plots for times to breakdown under dc stress at 70°C.

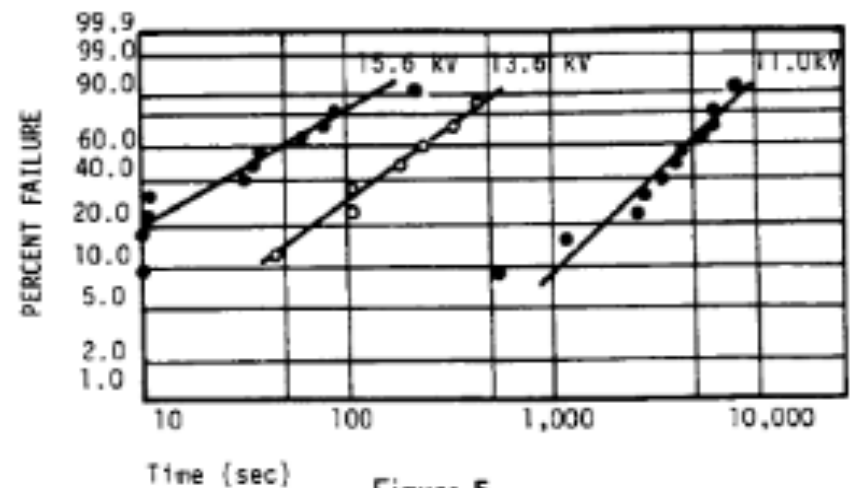

Figure 5.

Weibull plots for times to breakdown under dc stress at 90°C.

Cygan et al.: Lifetime of Films under Combined Stresses , IEEE Transactions on Electrical Insulation , vol. 24 No. 4, August 1989, p. 619

A
T
M
S
L

Failure modes

- Selfhealing

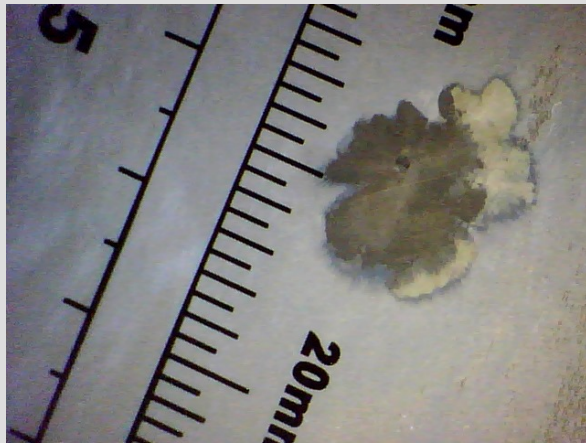

Corrosion



- Corona



A

T

M

S

L

