

Injection, extraction and transfer

- An accelerator has limited dynamic range.
- Chain of stages needed to reach high energy
- Periodic re-filling of storage rings, like LHC
- External experiments, like CNGS

Transfer lines transport the beam between accelerators, and onto targets, dumps, instruments etc.

LHC:	Large Hadron Collider
SPS:	Super Proton Synchrotron
AD:	Antiproton Decelerator
ISOLDE:	Isotope Separator Online Device
PSB:	Proton Synchrotron Booster
PS:	Proton Synchrotron
LINAC:	LINear Accelerator
LEIR:	Low Energy Ring
CNGS:	CERN Neutrino to Gran Sasso

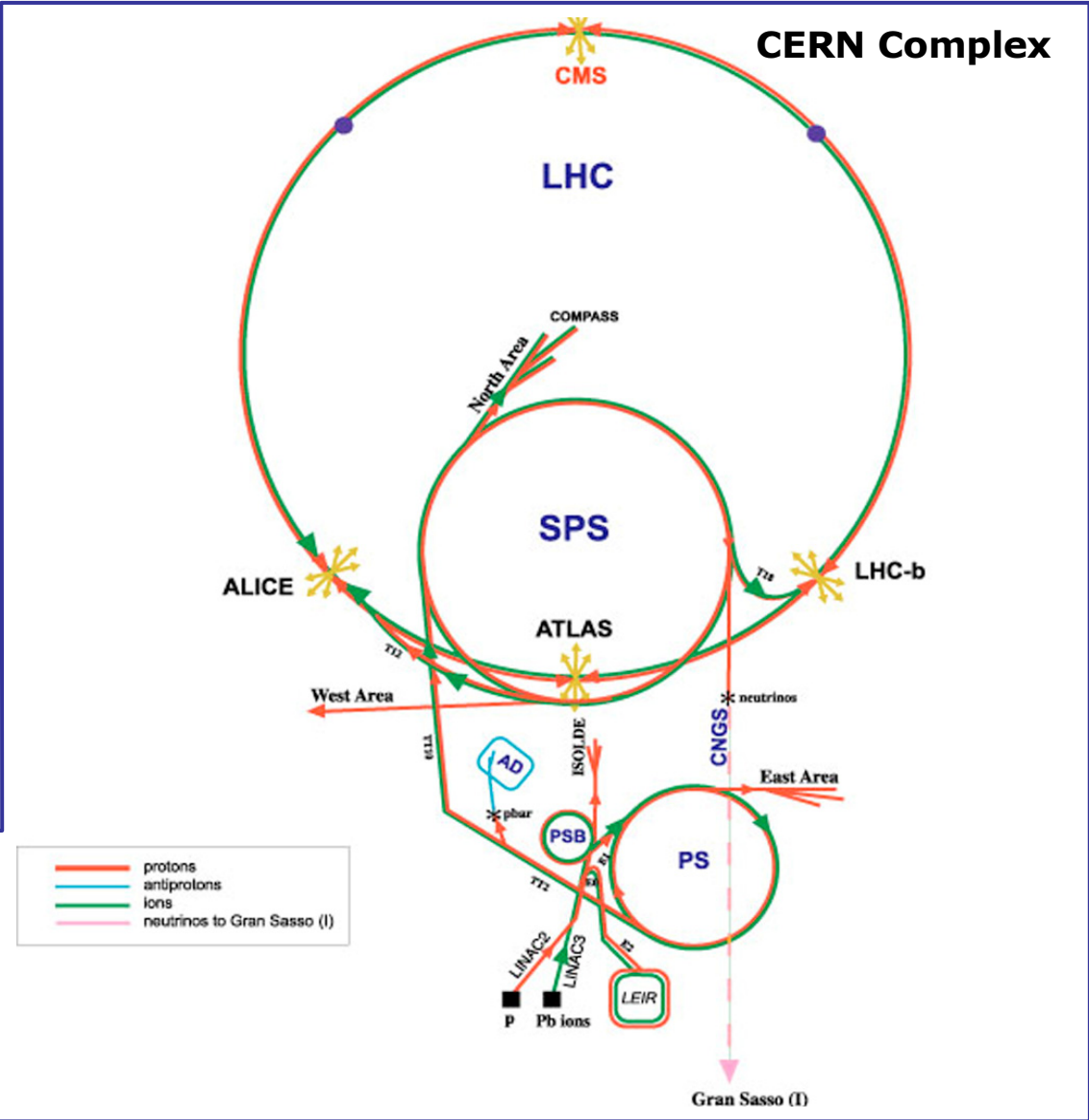

Beam Transfer lines

- Distinctions between transfer lines and circular machines
- Linking circular machines
- Trajectory correction
- Emittance and mismatch measurement
- Delivery precision and errors
- Blow-up from betatron mismatch
- Thin screens: blow-up and charge stripping

Normalised phase space

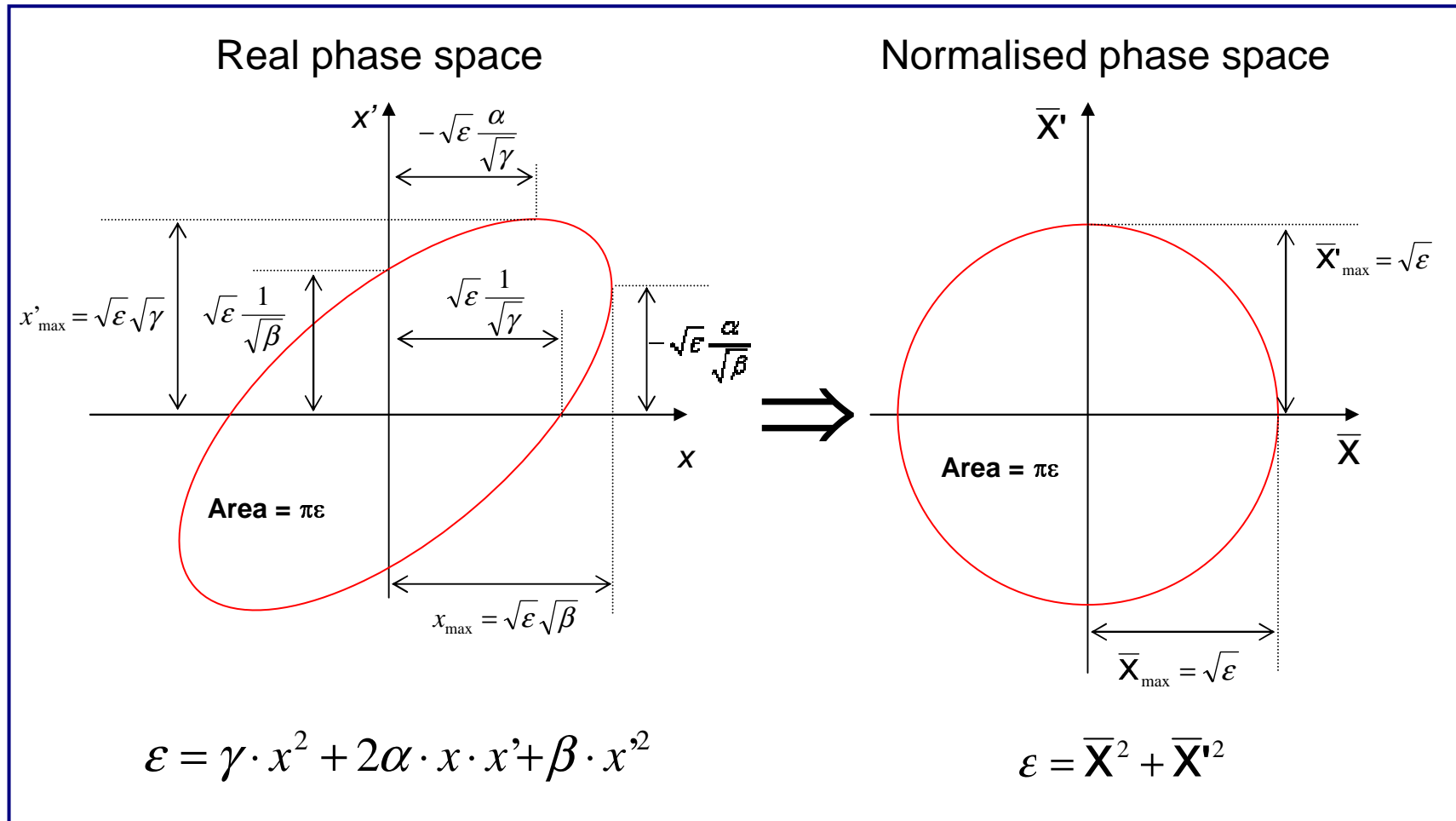

Distinction between Transfer Lines and Circular Machines

Moving from s_1 to s_2 through n elements



$$\begin{bmatrix} x_2 \\ x_2' \end{bmatrix} = \mathbf{M}_{1 \rightarrow 2} \cdot \begin{bmatrix} x \\ x' \end{bmatrix} = \begin{bmatrix} C & S \\ C' & S' \end{bmatrix} \cdot \begin{bmatrix} x \\ x' \end{bmatrix}$$

$$\mathbf{M}_{1 \rightarrow 2} = \prod_{i=1}^n \mathbf{M}_n$$

Circular Machine

Twiss parameterisation $M_{1 \rightarrow 2} = \begin{bmatrix} \sqrt{\beta_2/\beta_1} (\cos \Delta\mu + \alpha_1 \sin \Delta\mu) & \sqrt{\beta_1\beta_2} \sin \Delta\mu \\ \sqrt{1/\beta_1\beta_2} [(\alpha_1 - \alpha_2) \cos \Delta\mu - (1 + \alpha_1\alpha_2) \sin \Delta\mu] & \sqrt{\beta_1/\beta_2} (\cos \Delta\mu - \alpha_2 \sin \Delta\mu) \end{bmatrix}$

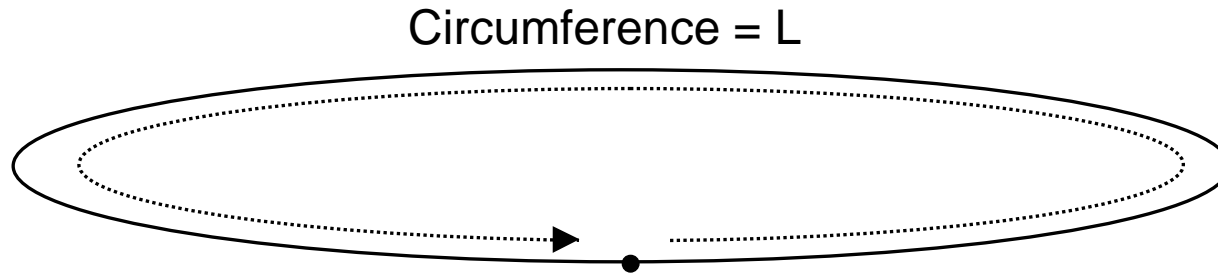

One turn $M_{1 \rightarrow 2} = M_{0 \rightarrow L} = \begin{bmatrix} \cos 2\pi Q + \alpha \sin 2\pi Q & \beta \sin 2\pi Q \\ -1/\beta (1 + \alpha^2) \sin 2\pi Q & \cos 2\pi Q - \alpha \sin 2\pi Q \end{bmatrix}$

- Periodicity condition for one turn (closed ring) imposes $\alpha_1 = \alpha_2, \beta_1 = \beta_2$
- This condition *uniquely* determines $\alpha(s), \beta(s)$ and $\mu(s)$ around the whole ring

Circular Machine

- Map the coordinates of a particle on each turn.
- Periodicity of the structure leads to regular motion
- Generate ellipse in phase space, defined by one set of α and β values \Rightarrow Matched Ellipse

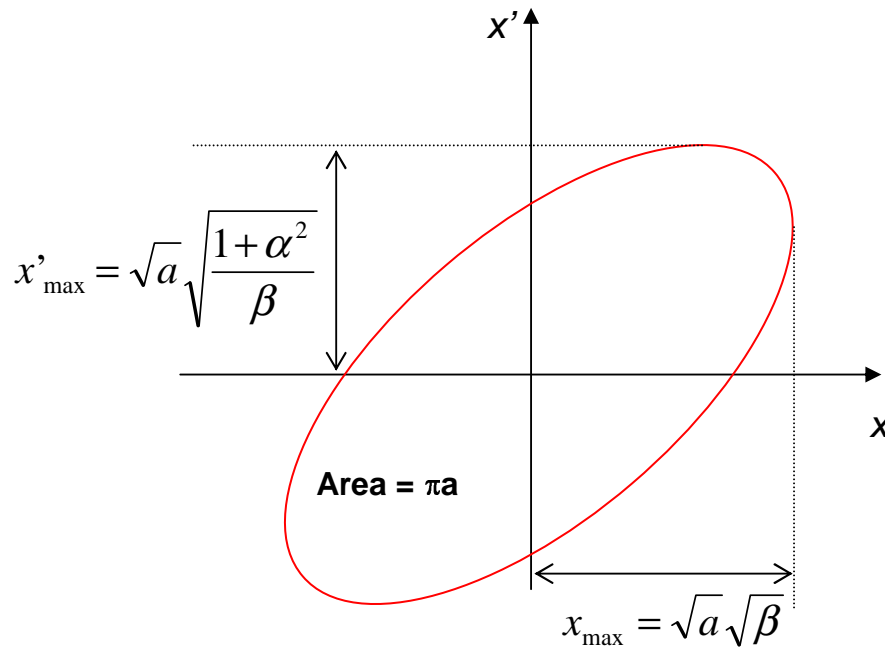

$$a = \gamma \cdot x^2 + 2\alpha \cdot x \cdot x' + \beta \cdot x'^2$$

$$\gamma = \frac{1 + \alpha^2}{\beta}$$

Circular Machine

- A beam injected with emittance ε , characterised by a different ellipse (α^* , β^*) generates (via filamentation) a large ellipse with the original α , β , but larger ε

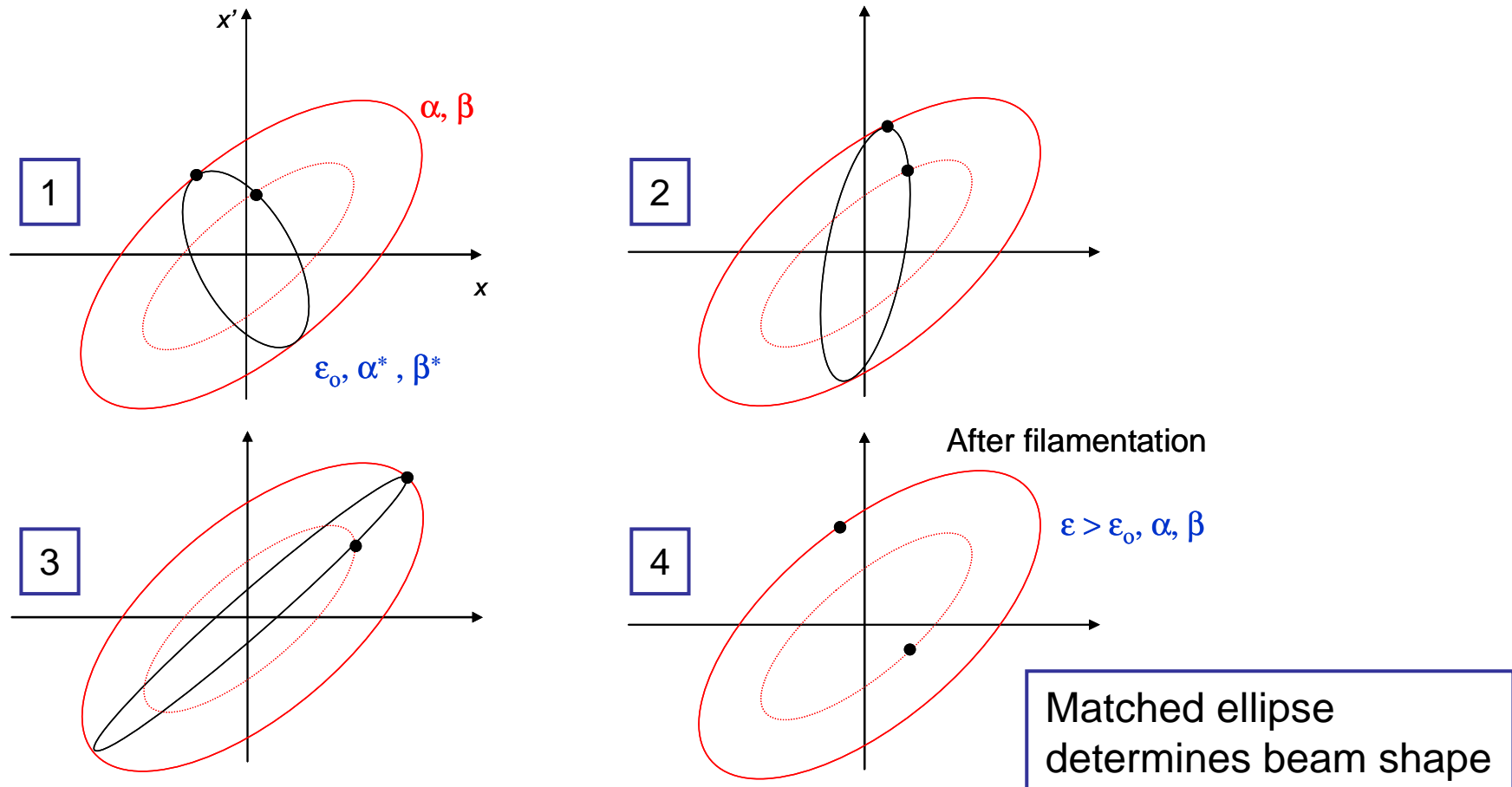

Transfer line

One pass
$$\begin{bmatrix} x_2 \\ x_2' \end{bmatrix} = \mathbf{M}_{1 \rightarrow 2} \cdot \begin{bmatrix} x \\ x' \end{bmatrix}$$

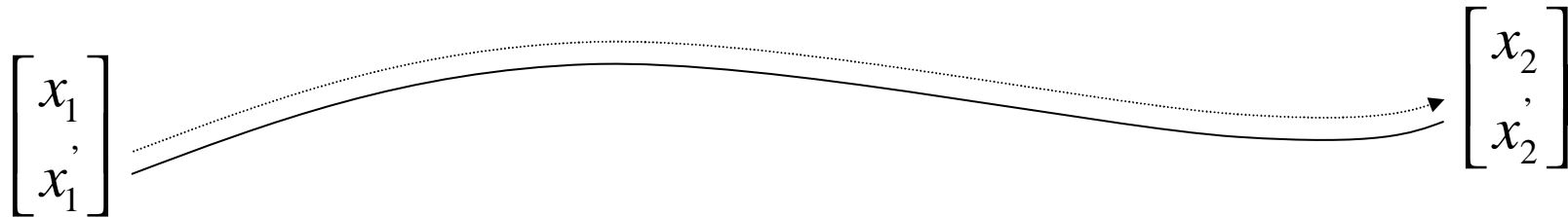

$$\mathbf{M}_{1 \rightarrow 2} = \begin{bmatrix} \sqrt{\beta_2/\beta_1} (\cos \Delta\mu + \alpha_1 \sin \Delta\mu) & \sqrt{\beta_1\beta_2} \sin \Delta\mu \\ \sqrt{1/\beta_1\beta_2} [(\alpha_1 - \alpha_2) \cos \Delta\mu - (1 + \alpha_1\alpha_2) \sin \Delta\mu] & \sqrt{\beta_1/\beta_2} (\cos \Delta\mu - \alpha_2 \sin \Delta\mu) \end{bmatrix}$$

- **No periodic condition exists**
- Twiss parameters are propagated from beginning to the end of the line
- At any point in the line, $\alpha(s)$ $\beta(s)$ are functions of α_1 β_1

Transfer line

- Map single particle coordinates at entrance and exit.
- Infinite number of possible starting ellipses...
- ...transported to infinite number of final ellipses

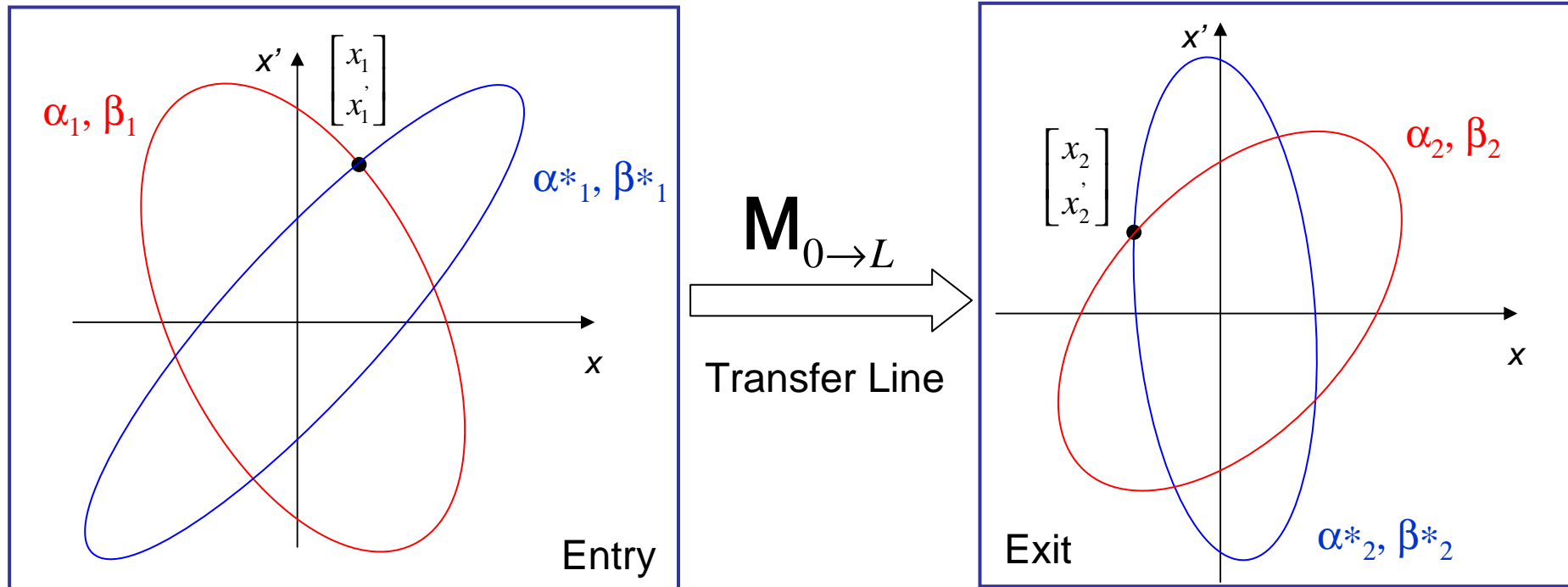

Transfer Line

- Initial α , β are defined for a transfer line by the beam shape at the entrance

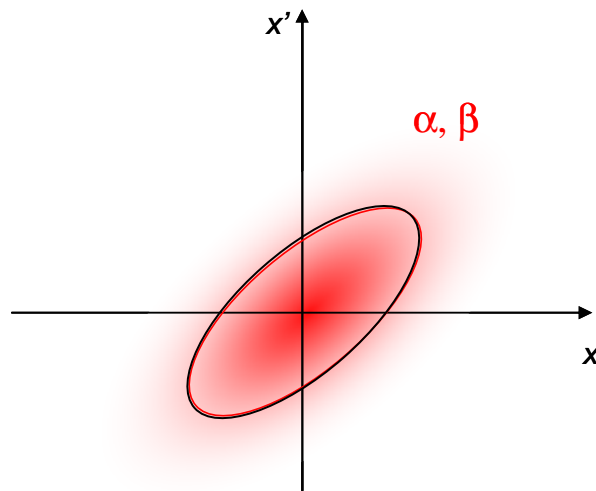

Gaussian beam

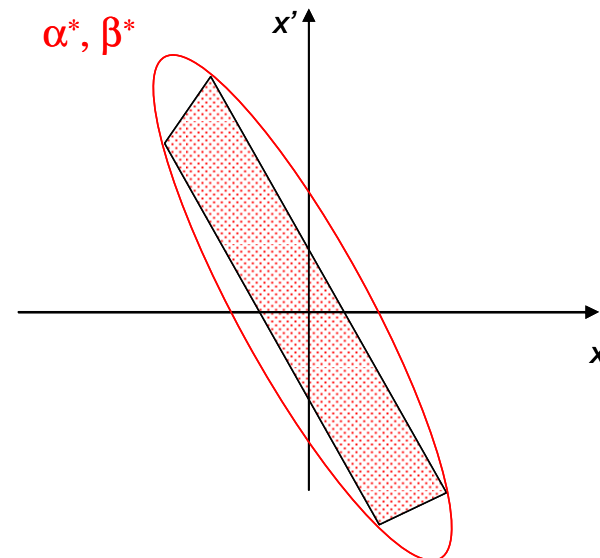

Non-Gaussian beam
(e.g. slow extracted)

- Propagation of this beam ellipse depends on the line
- Line optics is different for different input beams.

Linking Circular Machines

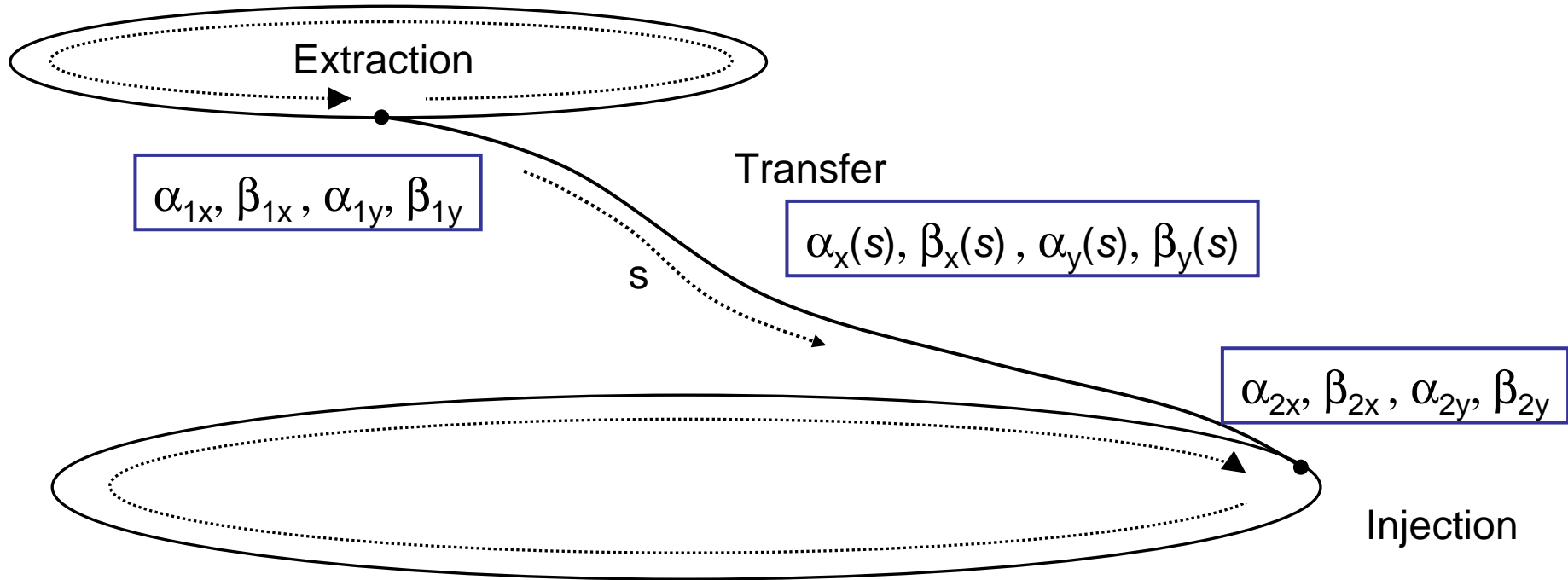

The Twiss parameters can be propagated when the transfer matrix \mathbf{M} is known

$$\begin{bmatrix} x_2 \\ x_2' \end{bmatrix} = \mathbf{M}_{1 \rightarrow 2} \cdot \begin{bmatrix} x \\ x' \end{bmatrix} = \begin{bmatrix} C & S \\ C' & S' \end{bmatrix} \cdot \begin{bmatrix} x \\ x' \end{bmatrix}$$

$$\begin{bmatrix} \beta_2 \\ \alpha_2 \\ \gamma_2 \end{bmatrix} = \begin{bmatrix} C^2 & -2CS & S^2 \\ -CC' & CS'+SC' & -SS' \\ C'^2 & -2C'S' & S'^2 \end{bmatrix} \cdot \begin{bmatrix} \beta_1 \\ \alpha_1 \\ \gamma_1 \end{bmatrix}$$

Linking Circular Machines

- Constraints include
 - Matching the trajectories
 - Minimum bend radius
 - Magnet aperture
 - Cost
 - Geology

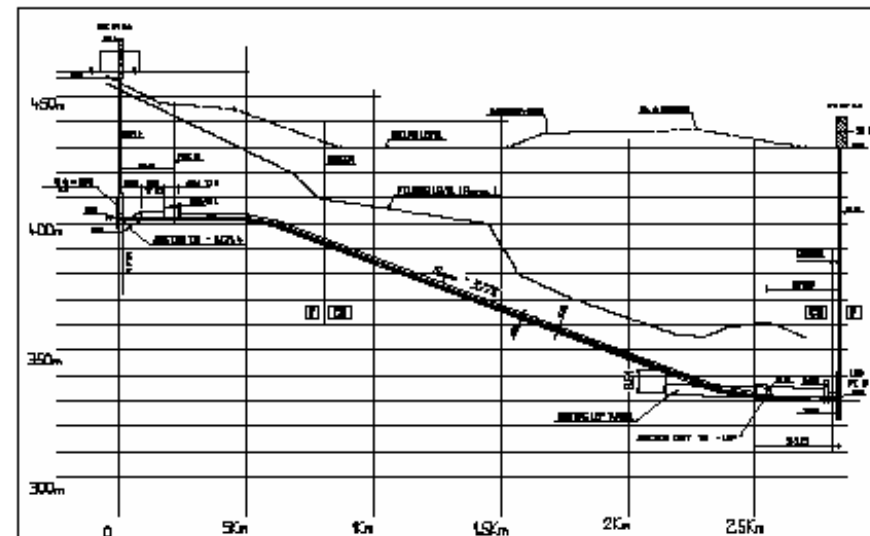
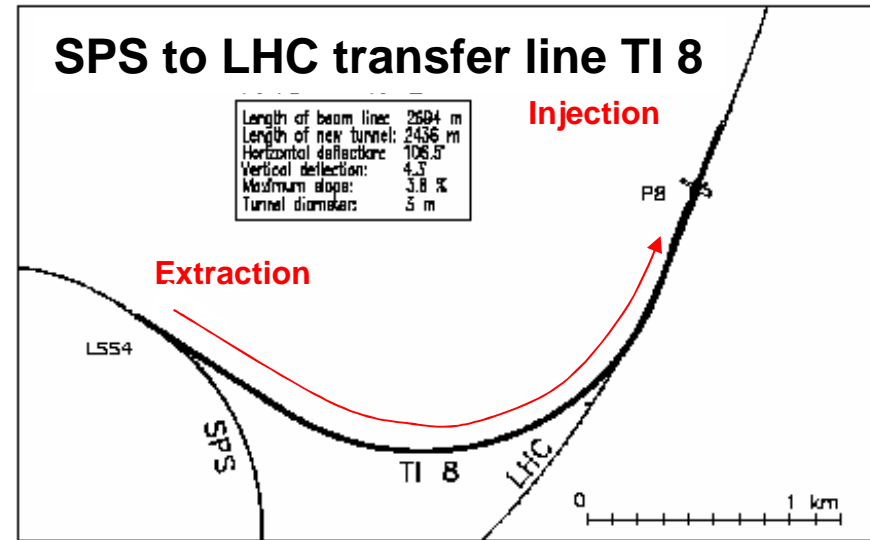

Linking Circular Machines

- Matching the optics is a non-trivial process
 - Parameters at start of line have to be propagated to matched parameters at the end of the line
 - Need in theory to match 8 variables ($\alpha_x \beta_x D_x D'_x$ and $\alpha_y \beta_y D_y D'_y$)
 - Maximum β and D values are imposed by magnet apertures
 - Other constraints can exist (e.g. phase conditions for collimators, insertions for special equipment, like foils)
- Long transfer lines ideally designed in 3 separate sections
 - Regular central FODO section – F and D quads at regular spacing, (+ bending dipoles)
 - Initial and final matching sections – independently powered quadrupoles, with sometimes irregular spacing.

Linking Circular Machines

- Example – SPS to LHC transfer line TI 8 (2700m long)

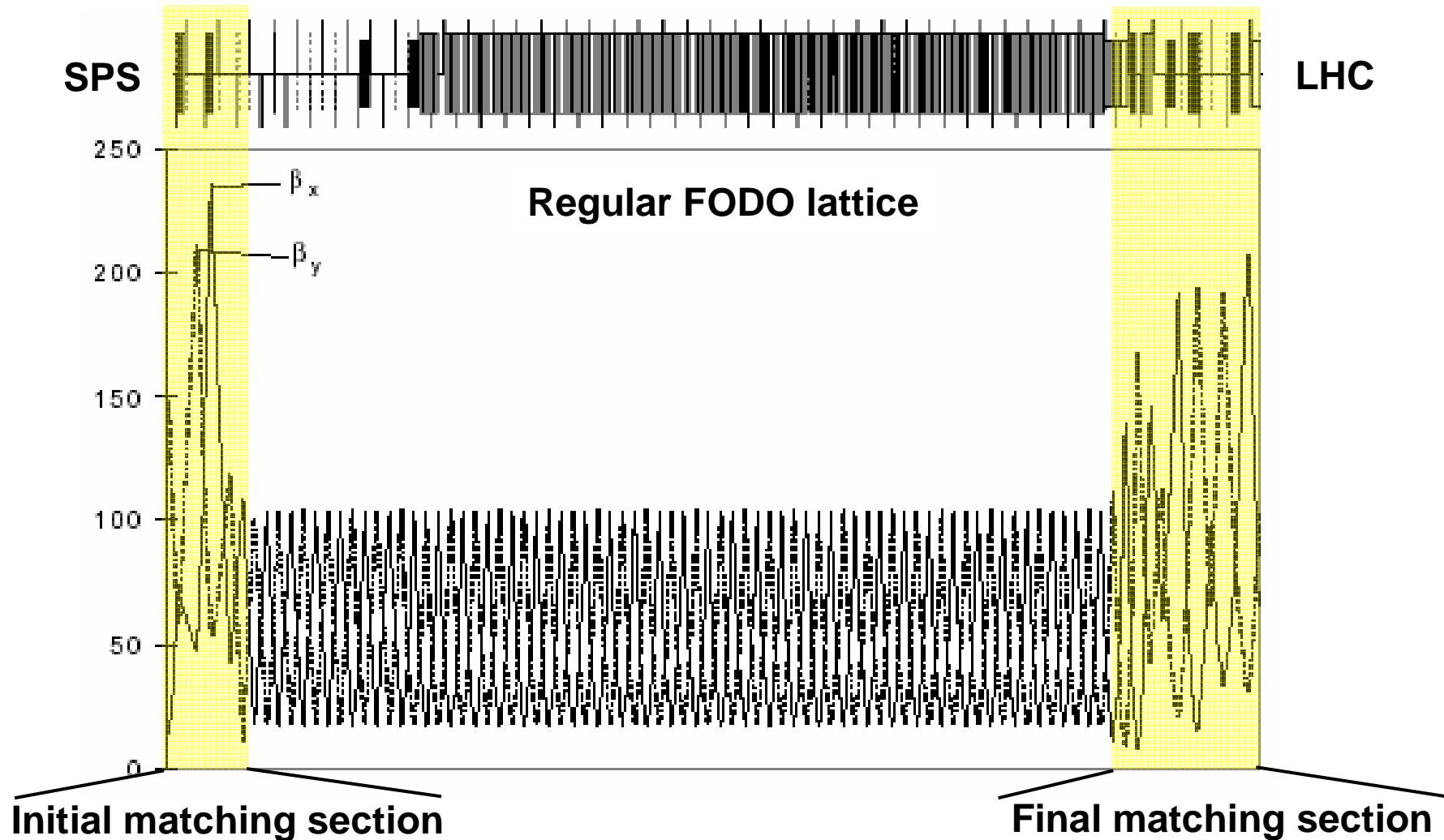

Linking Circular Machines

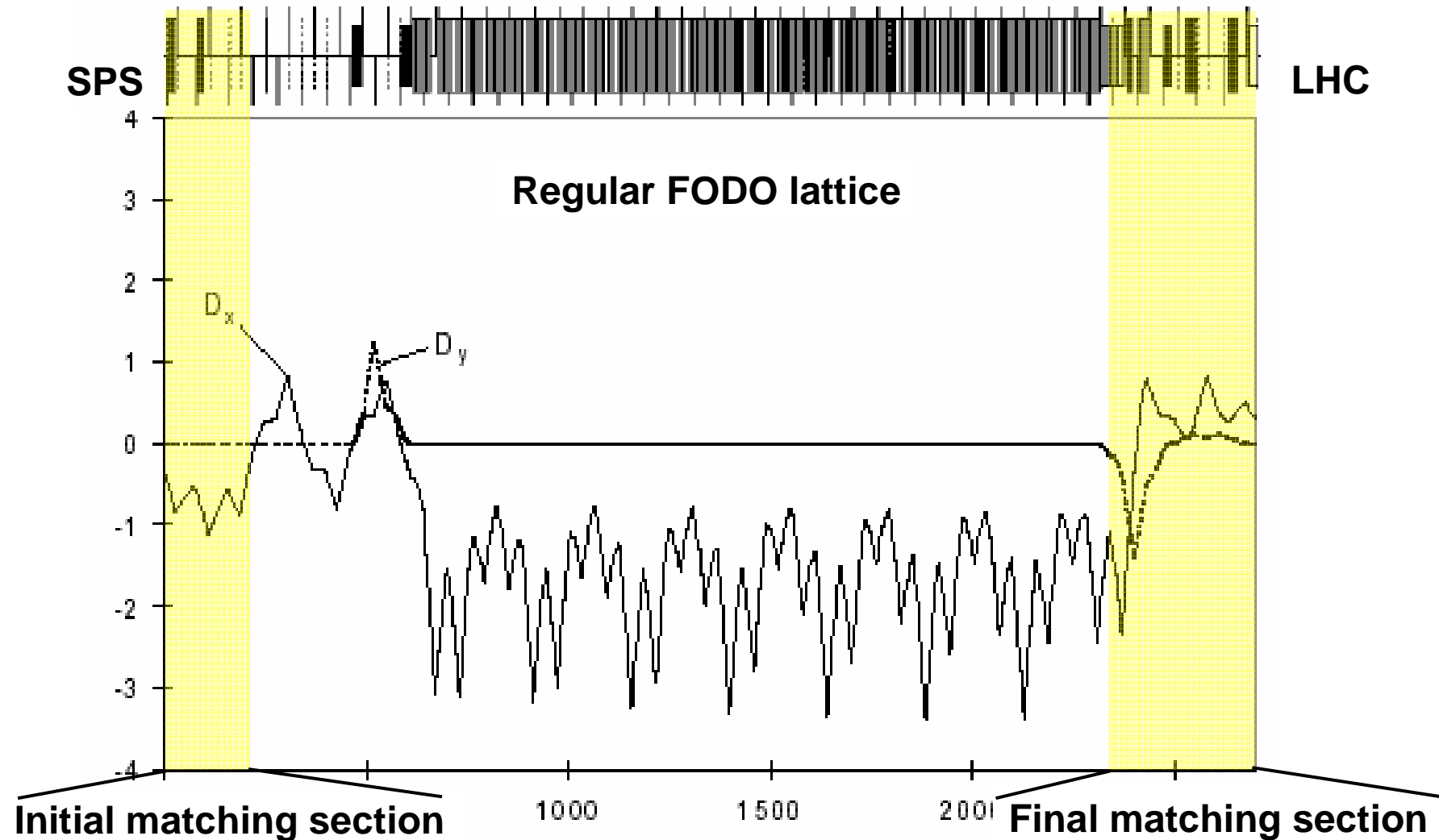

Aperture

- Available aperture for the beam depends on optics (β , D), trajectory O , mechanical and alignment tolerance M , magnet aperture A , beam energy spread $\Delta p/p$ and emittance ε .
- Use general expression to evaluate number of beam σ available (k = factor to allow for optical errors, typically 1.1)

$$n\sigma_y = \frac{A_y - O_y - M_y}{k\sqrt{\beta_y\varepsilon_y + \left(D_y|\Delta p/p\right)^2}}$$

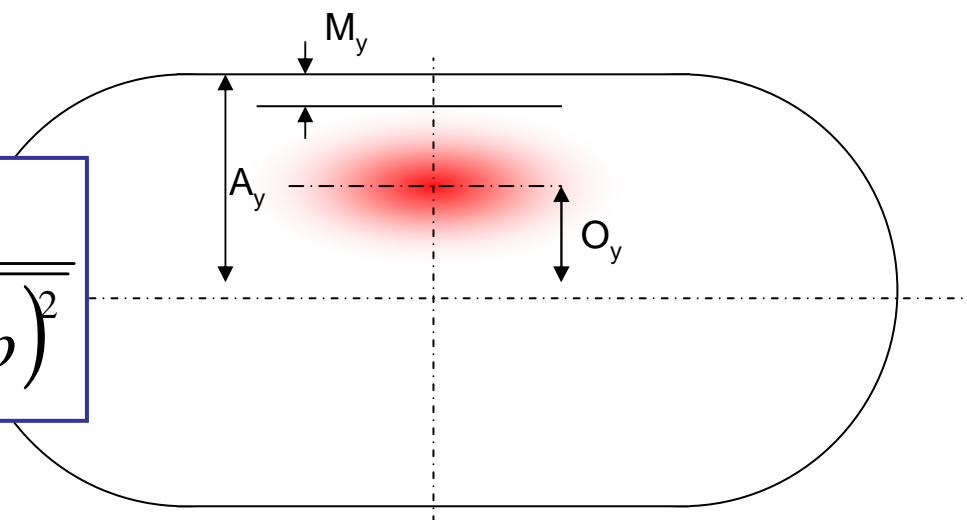

Aperture

- Aperture can be evaluated with optics and physical line description
- Critical areas can be fitted with extra instruments or correctors.

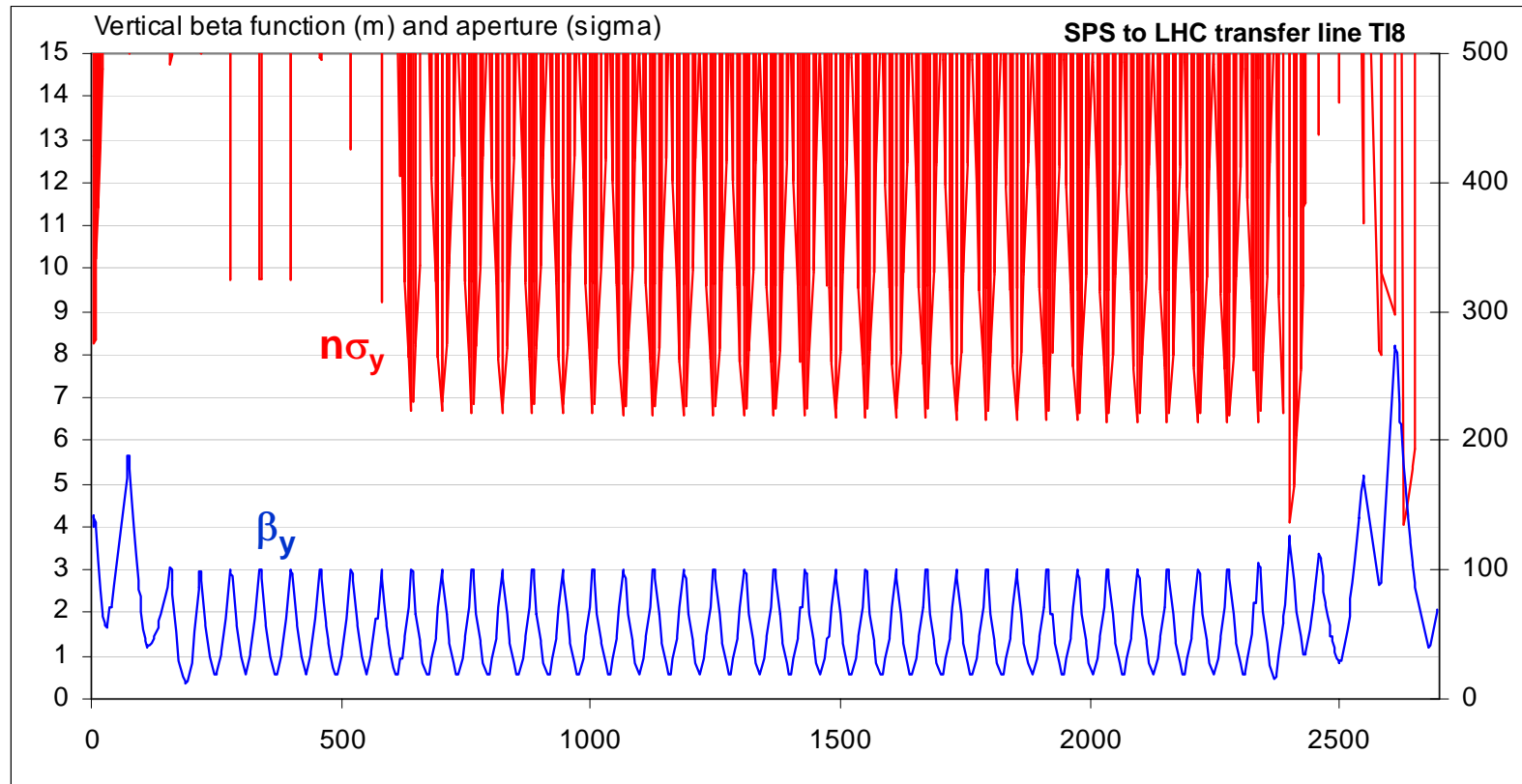

Trajectory correction

- Trajectory correction (steering) relatively straightforward.
- Use steering dipole magnets (correctors) to displace beam.
- Measure the response using a monitor (pick-up) downstream ($\pi/2$, $3\pi/2$, ...).
- Separate horizontal and vertical elements.
- H-correctors and pick-ups located at F-quadrupoles (large β_x).
- V-correctors and pick-ups located at D-quadrupoles (large β_y).
- In long lines, not all quadrupoles are equipped...

Trajectory correction

- Steering in matching sections, extraction and injection region requires more care
 - Often very limited in aperture
 - Injection oscillations important for performance
- Global correction can be used which attempts to minimise the RMS offsets at the BPMs, using all or some of the available corrector magnets.
- Example – SPS to LHC transfer line TI 8 – correction
 - Random alignment and field errors simulated; trajectory measured with all or some of available BPMs
 - Correction made with dedicated corrector dipole magnets

Trajectory correction

Uncorrected trajectory,
with y growing as a
result of random errors
in the line.

The RMS at the BPMs
is 3.4 mm, and y_{\max} is
12.0mm

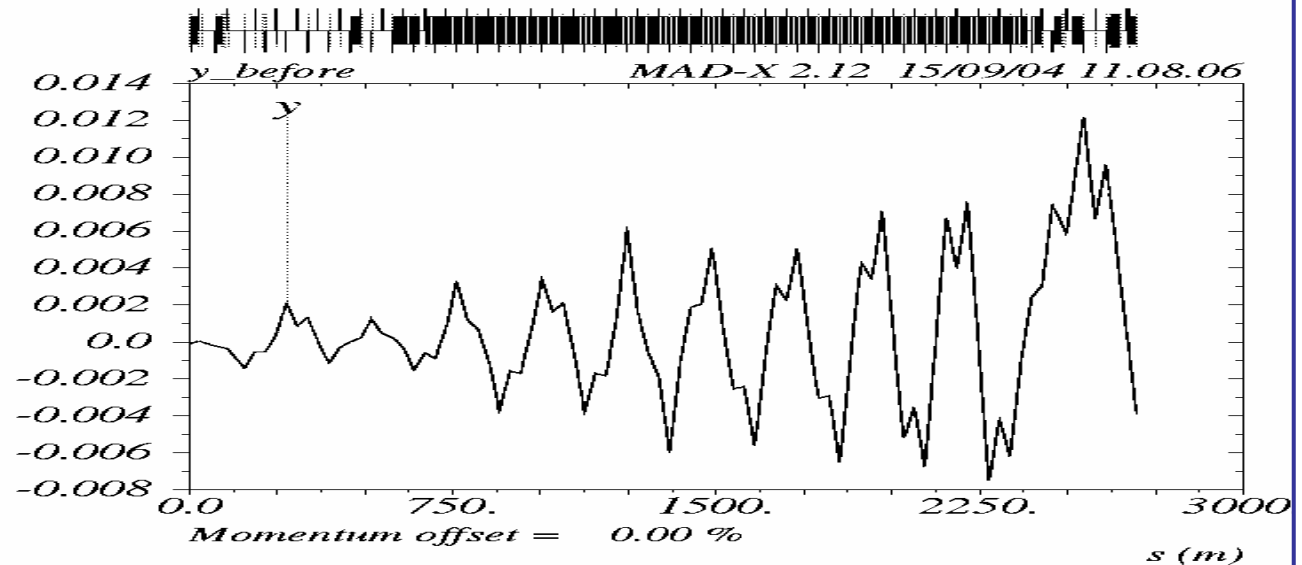

Corrected trajectory.

The RMS at the BPMs
is 0.3mm and y_{\max} is
1mm

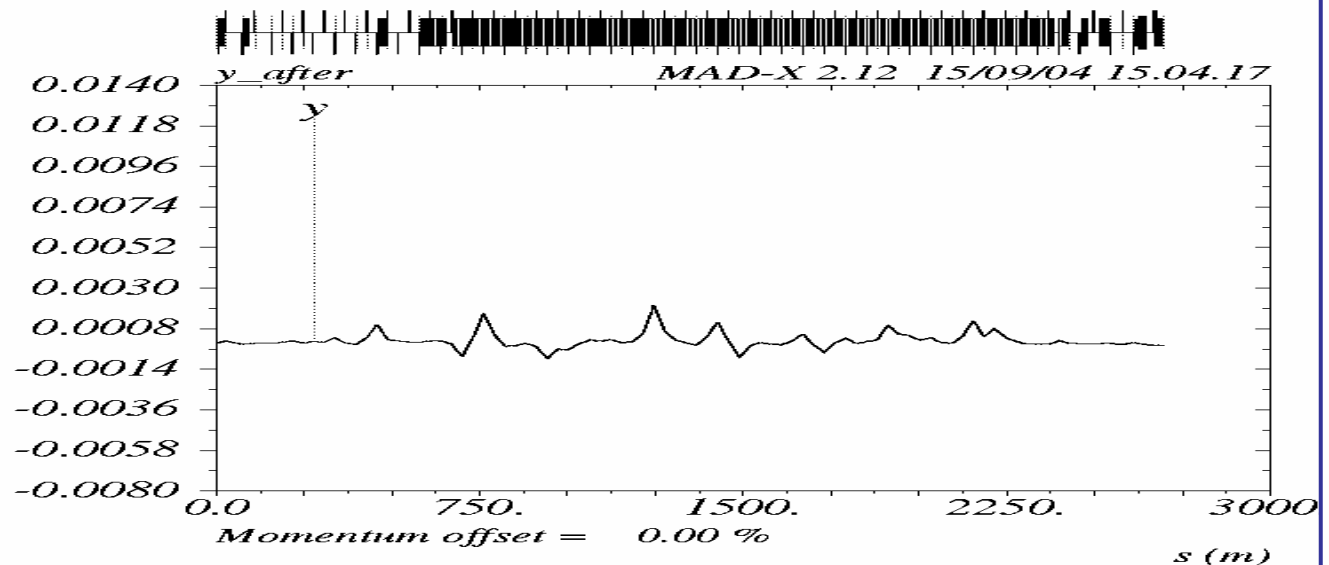

Trajectory correction

Uncorrected trajectory, with y growing as a result of random errors in the line.

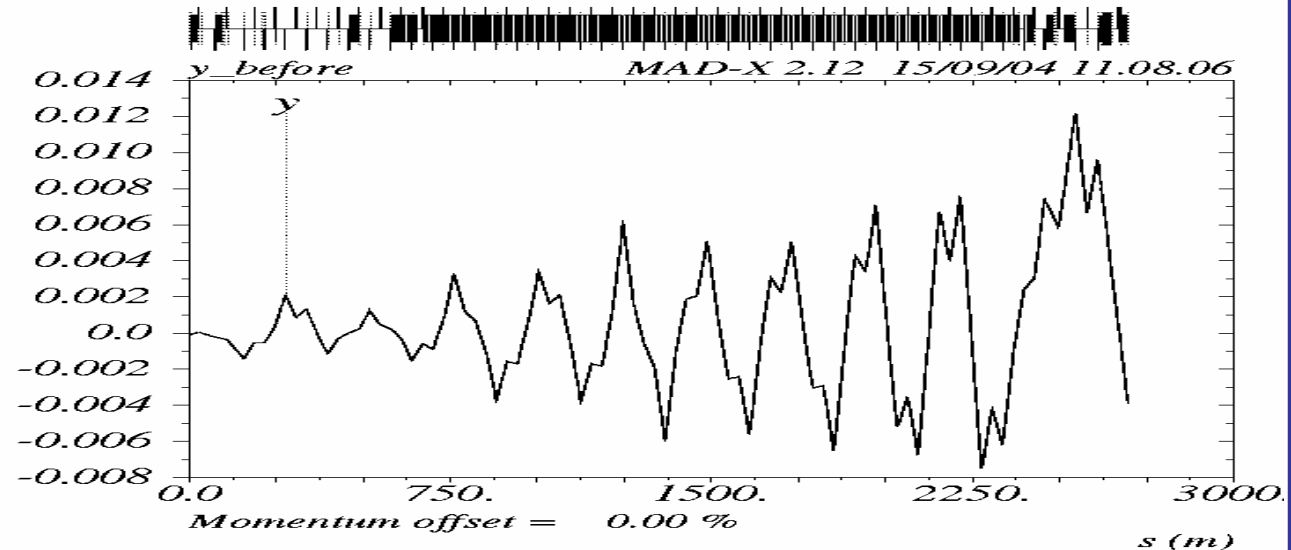

Correction with some monitors disabled

If the BPM phase sampling is poor, the correction algorithm can make the trajectory very bad, while all the monitor readings being ~zero....

... in this case
 $185\text{mm } y_{\max}$!

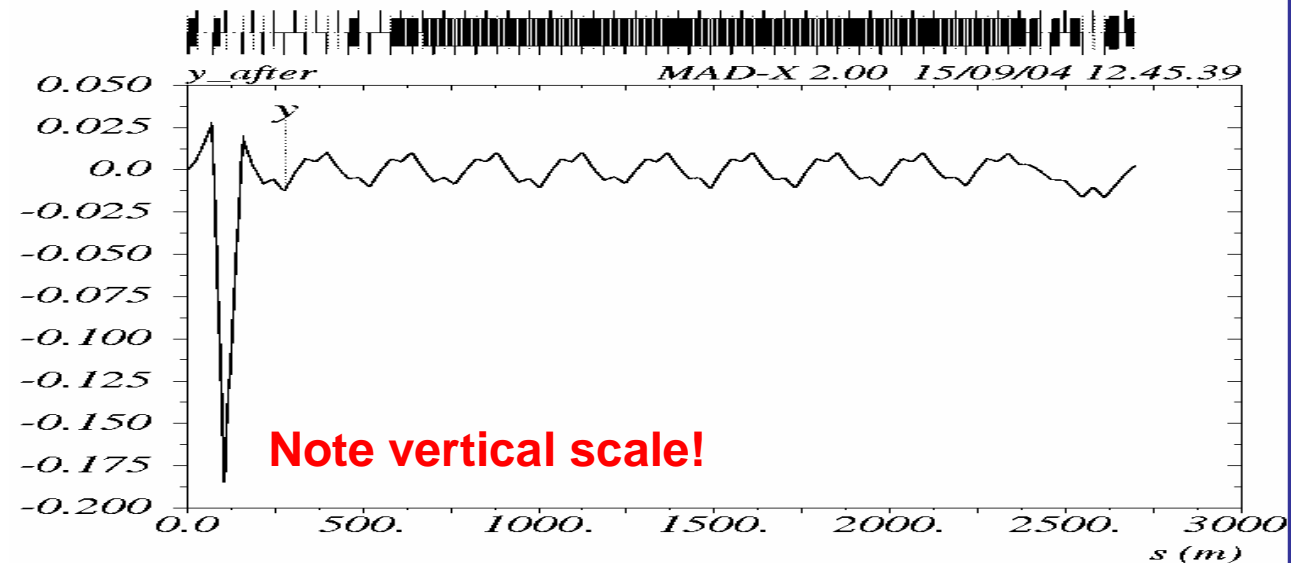

Delivery precision

- Precise delivery of the beam is important.
 - To avoid injection oscillations and emittance growth in rings
 - For stability on secondary particle production targets
 - Express injection error in σ

$$\Delta a = \sqrt{(\mathbf{x}^2 + \mathbf{x}'^2)} = \sqrt{(\gamma x^2 + 2\alpha x x' + \beta x'^2)}$$
$$\Delta a/\sigma = \sqrt{(\beta a/\beta e)} = \sqrt{[(\gamma x^2 + 2\alpha x x' + \beta x'^2)/\epsilon]}$$

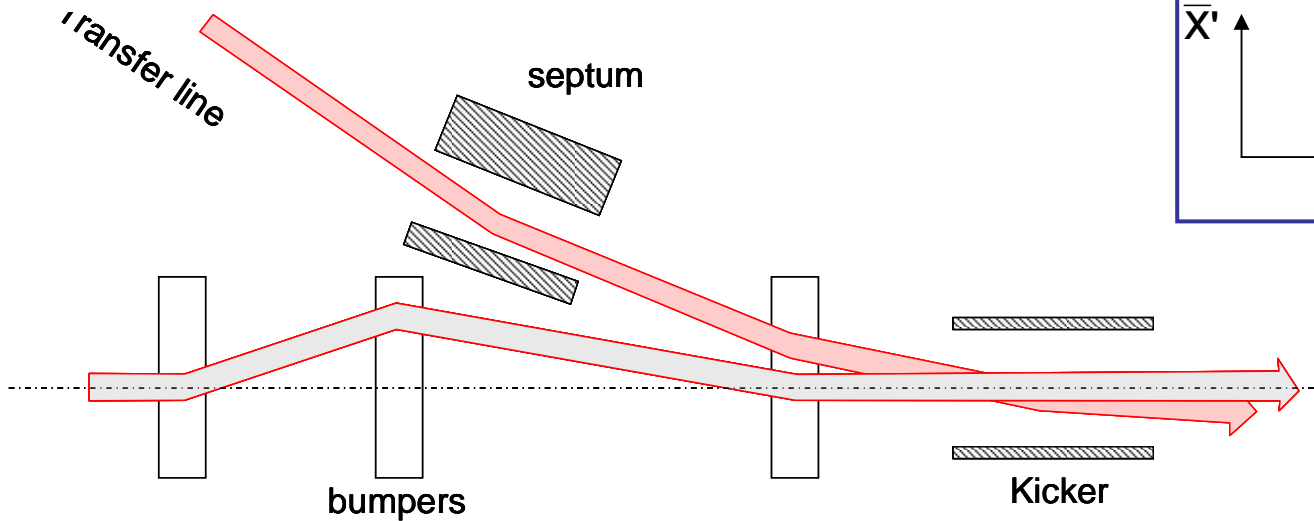
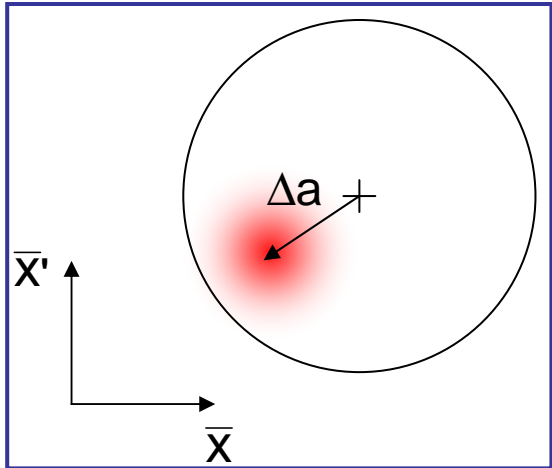

Delivery precision

- Static effects (e.g. from errors in alignment, field, calibration, ...) are dealt with by trajectory correction (steering).
- Also dynamic effects which vary with each injection.
 - Power supply ripples
 - Random effects like temperature variation
 - Systematic effects like kicker waveforms
- These dynamic effect produce a variable injection offset which can vary from batch to batch, or even within a batch.

Delivery precision

- The errors in a line superimpose
 - For uncorrelated errors the effects can be added quadratically
 - For correlated errors the effects must be added linearly
- The typical pattern of errors can be generated with a Monte-Carlo simulation
- Worst-case errors in families of magnets can be calculated analytically by introducing field errors into the Accelerator design code and calculating the resulting $\Delta a/\varepsilon$

Delivery precision

- Example –power supply ripples in SPS to LHC line TI 8.

Family / element	rms $\pm\Delta I/I_{max}$	x mm	x' mrad	y mm	y' mrad	$\Delta a_x/\sigma$	$\Delta a_y/\sigma$
Quadrupole MQF	5.0E-05	0.0006	0.0000	0.0001	0.0000	0.004	0.002
Quadrupole MQD	5.0E-05	0.0006	0.0000	0.0001	0.0000	0.004	0.002
Bumper MPLH	2.8E-04	0.0043	-0.0005	0.0000	0.0000	0.022	0.000
Septum MSE	1.3E-04	0.0282	0.0015	0.0000	0.0000	0.130	0.000
Dipole BH1	5.0E-05	0.0096	-0.0010	0.0000	0.0000	0.055	0.000
Dipole BH2	5.0E-05	0.0501	-0.0015	0.0000	0.0000	0.083	0.000
Dipole BH3	5.0E-05	-0.0008	0.0002	0.0000	0.0000	0.014	0.000
Dipole BH4	5.0E-05	-0.0030	-0.0010	0.0000	0.0000	0.088	0.000
Dipole MBI	2.5E-05	-0.0509	0.0013	0.0088	0.0005	0.091	0.035
Dipole BV1	5.0E-05	0.0000	0.0000	-0.0001	0.0002	0.000	0.021
Dipole BV2	5.0E-05	0.0000	0.0000	0.0187	-0.0005	0.000	0.084
Septum BH5A	5.0E-05	-0.0059	-0.0002	0.0000	0.0000	0.033	0.000
Septum BH5B	5.0E-05	-0.0140	-0.0002	0.0000	0.0000	0.058	0.000
Kicker MKE	2.5E-04	0.0035	-0.0003	0.0000	0.0000	0.012	0.000
Kicker MKI	2.5E-04	0.0000	0.0000	-0.0023	-0.0002	0.000	0.018

rms ▾ **0.220** ▾ **0.095**
linear sum **0.594** **0.162**

Blow-up from betatron mismatch

- Optical errors occur in transfer line and ring, such that the beam can be injected with a mismatch.
- Filamentation will produce an emittance increase.
- In normalised phase space, consider the matched beam as a circle, and the mismatched beam as an ellipse.

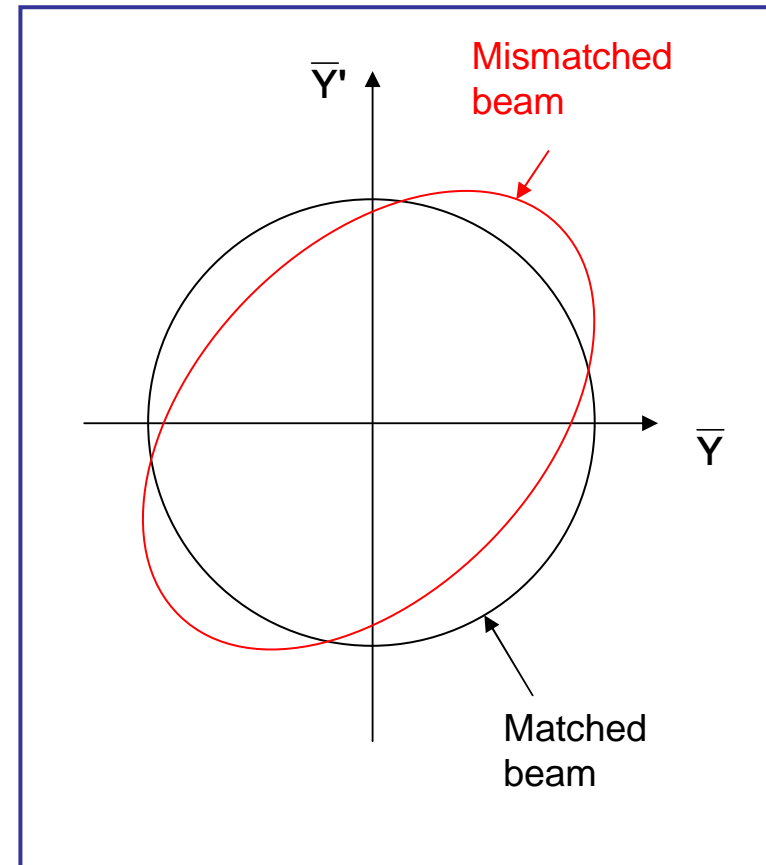

Blow-up from betatron mismatch

General betatron motion

$$y_2 = \sqrt{\varepsilon_2 \beta_2} \sin(\phi + \phi_o)$$

$$y'_2 = \sqrt{\varepsilon_2 / \beta_2} [\cos(\phi + \phi_o) - \alpha_2 \sin(\phi + \phi_o)]$$

applying the normalising transformation for the matched beam

$$\begin{bmatrix} \bar{Y}_2 \\ \bar{Y}'_2 \end{bmatrix} = \sqrt{\frac{1}{\beta_1}} \cdot \begin{bmatrix} 1 & 0 \\ \alpha_1 & \beta_1 \end{bmatrix} \cdot \begin{bmatrix} y_2 \\ y'_2 \end{bmatrix}$$

an ellipse is obtained in normalised phase space

$$A^2 = \bar{Y}_2^2 \left[\frac{\beta_1}{\beta_2} + \frac{\beta_2}{\beta_1} \left(\alpha_1 - \alpha_2 \frac{\beta_1}{\beta_2} \right)^2 \right] + \bar{Y}'_2^2 \frac{\beta_2}{\beta_1} - 2\bar{Y}_2 \bar{Y}'_2 \left[\frac{\beta_2}{\beta_1} \left(\alpha_1 - \alpha_2 \frac{\beta_1}{\beta_2} \right) \right]$$

characterised by γ_{new} , β_{new} and α_{new} , where

$$\alpha_{new} = \frac{-\beta_2}{\beta_1} \left(\alpha_1 - \alpha_2 \frac{\beta_1}{\beta_2} \right) \quad \beta_{new} = \frac{\beta_2}{\beta_1}, \quad \gamma_{new} = \frac{\beta_1}{\beta_2} + \frac{\beta_2}{\beta_1} \left(\alpha_1 - \alpha_2 \frac{\beta_1}{\beta_2} \right)^2$$

Blow-up from betatron mismatch

From the general ellipse properties*

$$a = \frac{A}{\sqrt{2}} (\sqrt{H+1} + \sqrt{H-1}) \quad b = \frac{A}{\sqrt{2}} (\sqrt{H+1} - \sqrt{H-1})$$

where

$$H = \frac{1}{2} (\gamma_{new} + \beta_{new})$$

$$= \frac{1}{2} \left(\frac{\beta_1}{\beta_2} + \frac{\beta_2}{\beta_1} \left(\alpha_1 - \alpha_2 \frac{\beta_1}{\beta_2} \right)^2 + \frac{\beta_2}{\beta_1} \right)$$

and thus

$$\lambda = \frac{1}{\sqrt{2}} (\sqrt{H+1} + \sqrt{H-1}) \quad \frac{1}{\lambda} = \frac{1}{\sqrt{2}} (\sqrt{H+1} - \sqrt{H-1})$$

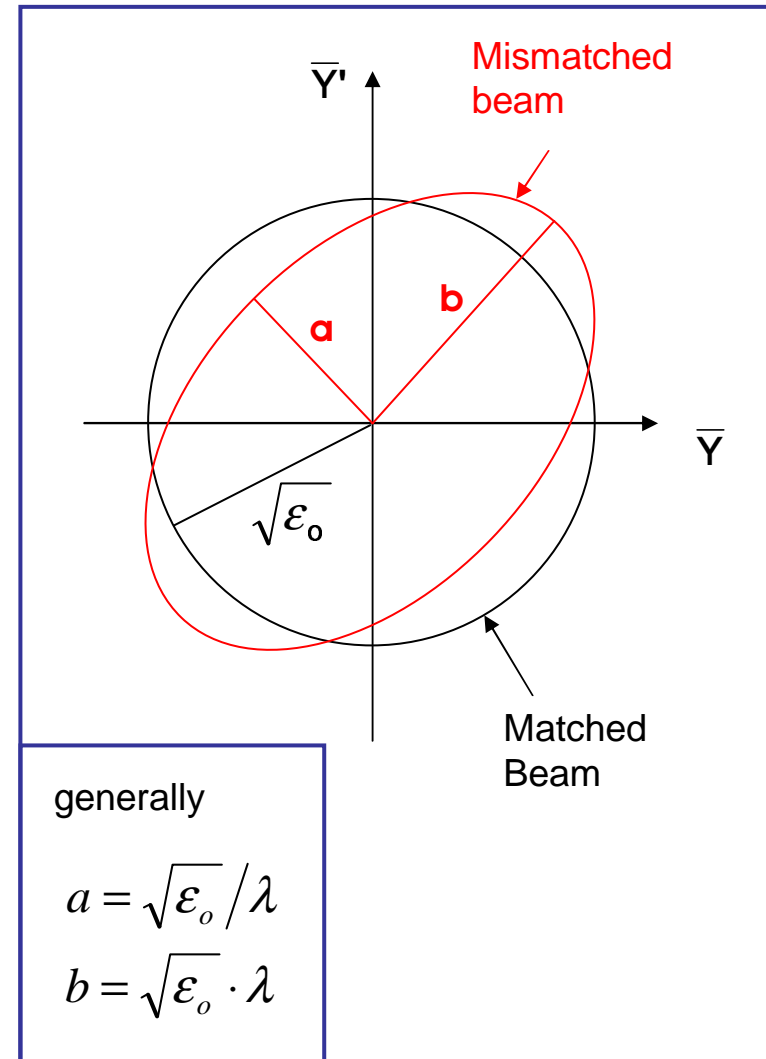

Blow-up from betatron mismatch

Since $\bar{Y}_2 = \lambda \cdot \sqrt{\varepsilon_0} \sin(\phi + \phi_o)$

$$\bar{Y}'_2 = \frac{1}{\lambda} \sqrt{\varepsilon_0} \cos(\phi + \phi_o)$$

We can evaluate the square of the distance of a particle from the origin as

$$\bar{Y}_2^2 + \bar{Y}'_2^2 = \lambda^2 \cdot \varepsilon_0 \sin^2(\phi + \phi_o) + \frac{1}{\lambda^2} \varepsilon_0 \cos^2(\phi + \phi_o)$$

The new emittance is the average over all phases

$$\varepsilon_{new} = \langle \bar{Y}_2^2 + \bar{Y}'_2^2 \rangle = \lambda^2 \varepsilon_0 \langle \sin^2(\phi + \phi_o) \rangle + \frac{1}{\lambda^2} \varepsilon_0 \langle \cos^2(\phi + \phi_o) \rangle = \frac{1}{2} \varepsilon_0 \left(\lambda^2 + \frac{1}{\lambda^2} \right)$$

Substituting back for λ gives

$$\varepsilon_{new} = \frac{1}{2} \varepsilon_0 \left(\lambda^2 + \frac{1}{\lambda^2} \right) = H \varepsilon_0 = \frac{1}{2} \varepsilon_0 \left(\frac{\beta_1}{\beta_2} + \frac{\beta_2}{\beta_1} \left(\alpha_1 - \alpha_2 \frac{\beta_1}{\beta_2} \right)^2 + \frac{\beta_2}{\beta_1} \right)$$

where subscript 1 refers to the matched ellipse, 2 refers to the mismatched ellipse.

Blow-up from betatron mismatch

A numerical example....

Consider $b = 3a$ for the mismatched ellipse

$$\lambda = \sqrt{b/a} = \sqrt{3}$$

$$\begin{aligned}\epsilon_{new} &= \frac{1}{2} \epsilon_0 (\lambda^2 + 1/\lambda^2) \\ &= 1.67 \epsilon_0\end{aligned}$$

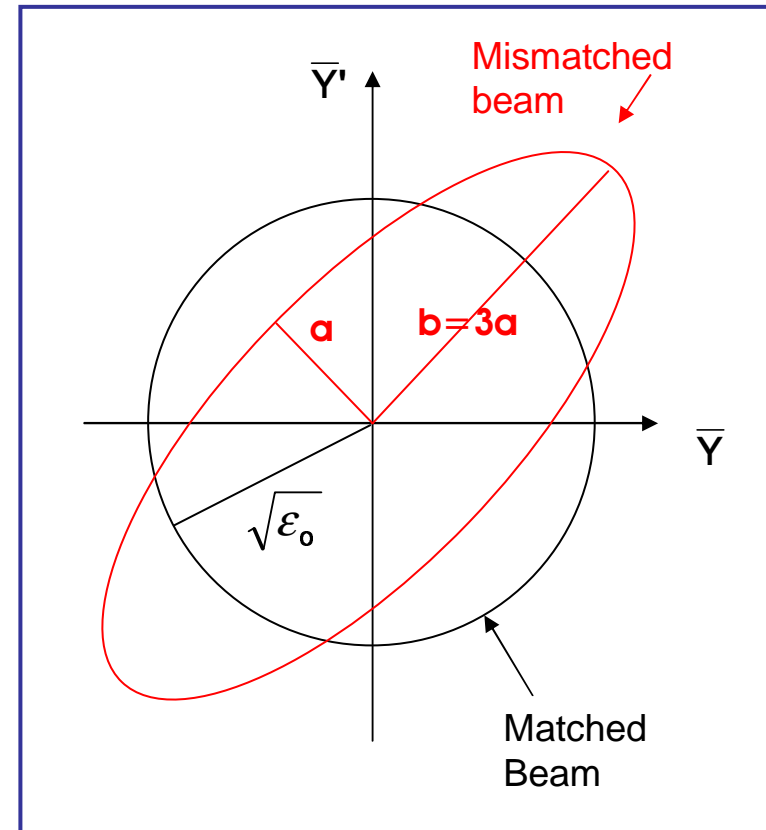

Emittance and mismatch measurement

- Beam screen provides density profile of the beam
- Use 1σ emittance definition: $\varepsilon = \sigma^2/\beta$
- Profile fit gives σ .

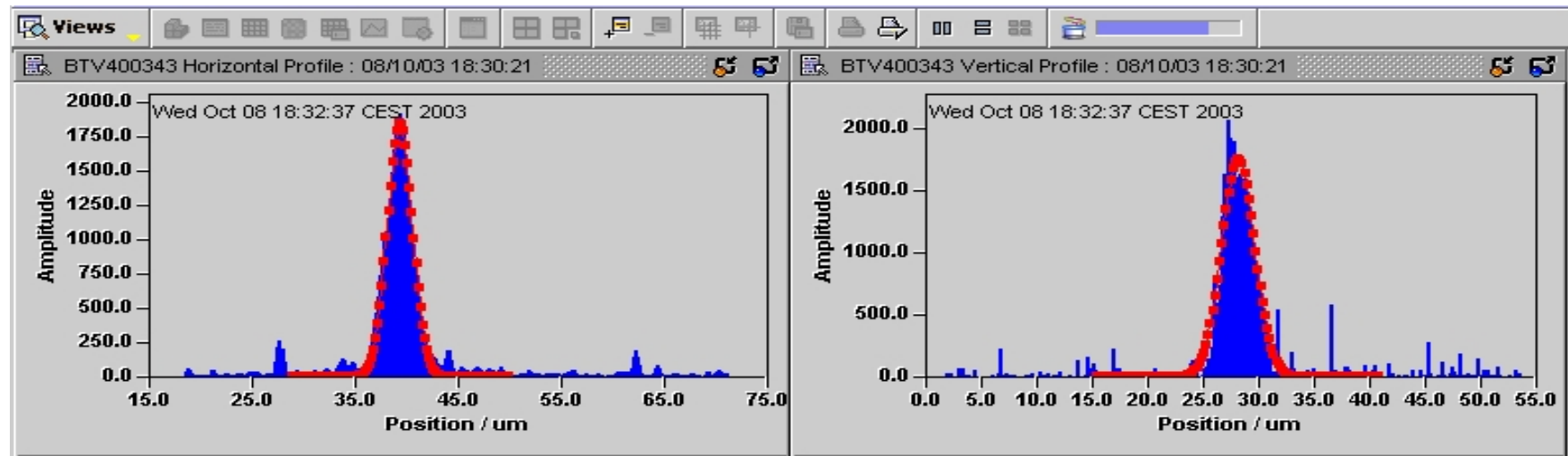

Emittance and mismatch measurement

- In a ring, β is known so ε can be calculated from a single screen
- In a line, need measurements at 3 screens, plus the two transfer matrices M_{01} and M_{12}
- 3 measurement locations allows determination of ε , α and β

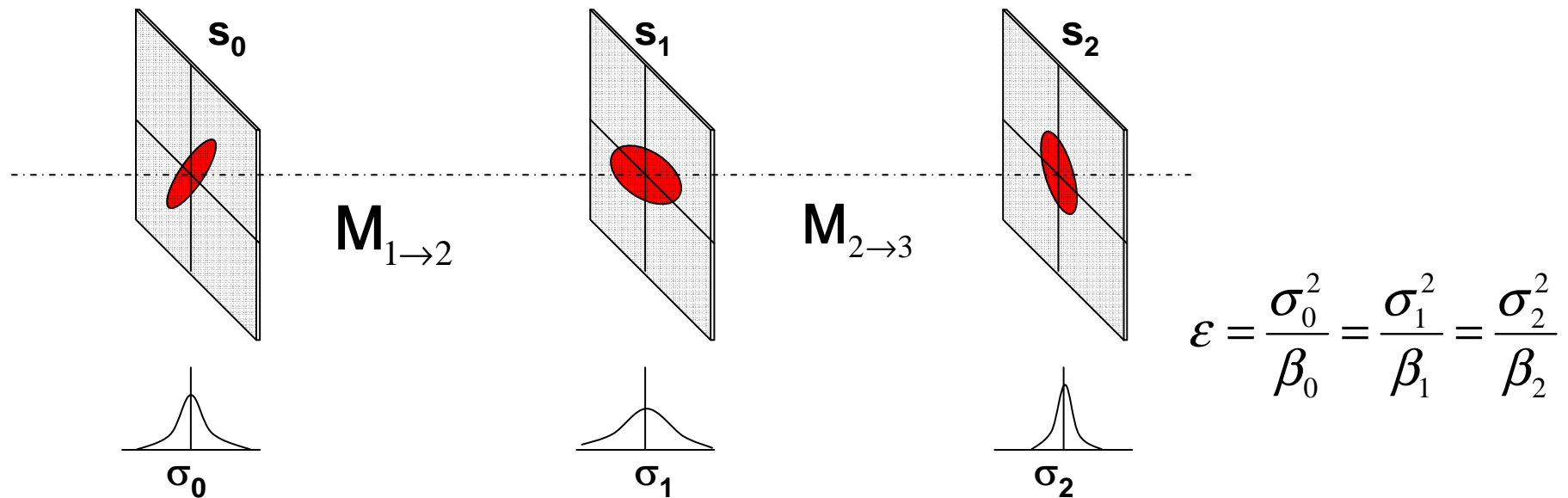

Emittance and mismatch measurement

We have

$$\begin{bmatrix} \beta_1 \\ \alpha_1 \\ \gamma_1 \end{bmatrix} = \begin{bmatrix} C^2 & -2CS & S^2 \\ -CC' & CS'+SC' & -SS' \\ C'^2 & -2C'S' & S'^2 \end{bmatrix} \cdot \begin{bmatrix} \beta_0 \\ \alpha_0 \\ \gamma_0 \end{bmatrix}$$

so that

$$\beta_1 = C_1^2 \beta_0 - 2C_1 S_1 \alpha_0 + \frac{S_1^2}{\beta_0} (1 + \alpha_0^2), \quad \beta_2 = C_2^2 \beta_0 - 2C_2 S_2 \alpha_0 + \frac{S_2^2}{\beta_0} (1 + \alpha_0^2)$$

using

$$\beta_0 = \frac{\sigma_0^2}{\varepsilon}, \quad \beta_1 = \left(\frac{\sigma_1}{\sigma_0} \right)^2 \beta_0, \quad \beta_2 = \left(\frac{\sigma_2}{\sigma_0} \right)^2 \beta_0$$

we find

$$\alpha_0 = \frac{1}{2} \beta_0 \mathbf{W}$$

where

$$\mathbf{W} = \frac{(\sigma_2 / \sigma_0)^2 / S_2^2 - (\sigma_1 / \sigma_0)^2 / S_1^2 - (C_2 / S_2)^2 + (C_1 / S_1)^2}{(C_1 / S_1) - (C_2 / S_2)}$$

Emittance and mismatch measurement

with
$$\beta_1 = C_1^2 \beta_0 - 2C_1 S_1 \alpha_0 + \frac{S_1^2}{\beta_0} (1 + \alpha_0^2) \quad \beta_2 = C_2^2 \beta_0 - 2C_2 S_2 \alpha_0 + \frac{S_2^2}{\beta_0} (1 + \alpha_0^2)$$

and
$$\beta_0 = \frac{\sigma_0^2}{\varepsilon}, \quad \beta_1 = \left(\frac{\sigma_1}{\sigma_0} \right)^2 \beta_0, \quad \beta_2 = \left(\frac{\sigma_2}{\sigma_0} \right)^2 \beta_0$$

and
$$W = \frac{(\sigma_2 / \sigma_0)^2 / S_2^2 - (\sigma_1 / \sigma_0)^2 / S_1^2 - (C_2 / S_2)^2 + (C_1 / S_1)^2}{(C_1 / S_1) - (C_2 / S_2)}$$

Some algebra with the three above equations gives

$$\beta_0 = 1 / \left| \sqrt{(\sigma_2 / \sigma_0)^2 / S_2^2 - (C_2 / S_2)^2 + W(C_2 / S_2)^2 - W^2 / 4} \right|$$

And finally we can evaluate

$$\varepsilon = \sigma_0^2 \beta_0$$

Comparing measured α_0, β_0 with expected values gives mismatch

Blow-up from thin scatterer

- Thin metal windows used to separate poor vacuum of transfer lines from good vacuum in circular machines.
- Thin beam screens ($\text{Al}_2\text{O}_3, \text{Ti}$) used to generate profiles.
- Emittance of the beam increases when it passes through, due to multiple Coulomb scattering.

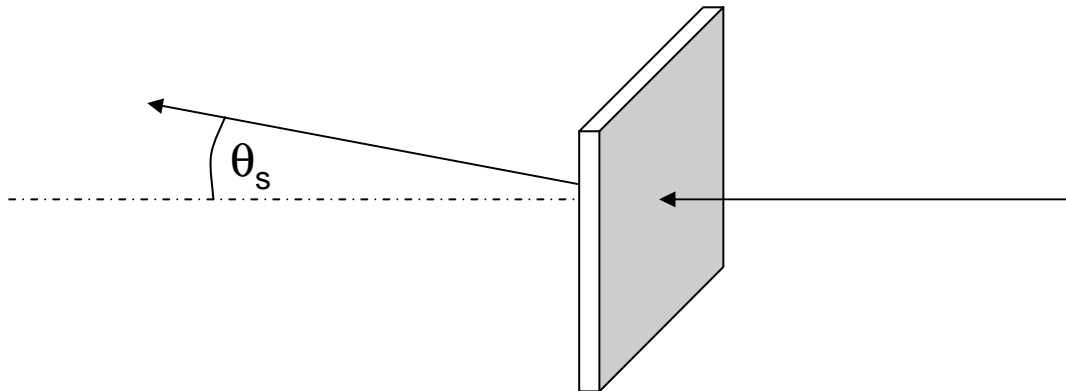

rms angle increase:
$$\sqrt{\langle \theta_s^2 \rangle} [mrad] = \frac{14.1}{\beta_c p [MeV/c]} Z_{inc} \sqrt{\frac{L}{L_{rad}}} \left(1 + 0.11 \cdot \log_{10} \frac{L}{L_{rad}} \right)$$

$\beta_c = v/c$, p = momentum, Z_{inc} = particle charge / e , L = target length, L_{rad} = radiation length

Blow-up from thin scatterer

particle with initial coordinates y_1, y_1'

$$y_2' = y_1' + \theta_s$$

rms distribution over whole beam becomes

$$\langle y_2'^2 \rangle = \langle y_1' + \theta_s \rangle = \langle y_1'^2 \rangle + \langle \theta_s^2 \rangle + 2\langle y_1' \theta_s \rangle$$

y_1' and θ_s are uncorrelated, so

$$2\langle y_1' \theta_s \rangle = 2\langle y_1' \rangle \langle \theta_s \rangle = 0$$

therefore

$$\langle y_2'^2 \rangle = \langle y_1'^2 \rangle + \langle \theta_s^2 \rangle$$

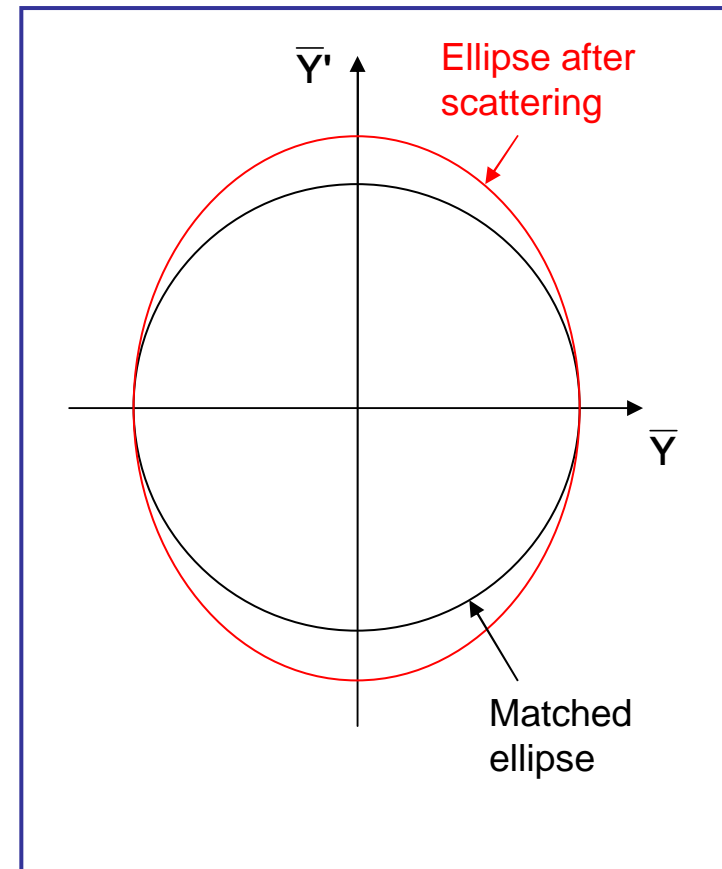

Blow-up from thin scatterer

After filamentation the average divergence is $\langle y_2'^2 \rangle = \langle y_1'^2 \rangle + \frac{1}{2} \langle \theta_s^2 \rangle$

Using $\varepsilon = \sigma^2 / \beta = \langle \bar{Y}^2 \rangle = \langle \bar{Y}'^2 \rangle$

and $\bar{Y}' = \sqrt{\frac{1}{\beta_s}} \cdot \alpha_s y + \sqrt{\beta_s} y'$

Gives $\varepsilon_2 = \frac{\alpha^2}{\beta} \langle y_2'^2 \rangle + 2\alpha \langle y_2 y_2' \rangle + \beta \langle y_2'^2 \rangle$

For a thin scatterer $\langle y_2'^2 \rangle = \langle y_1'^2 \rangle$ uncorrelated

Also $\langle y_2 y_2' \rangle = \langle y_1 (y_1' + \theta_s) \rangle = \langle y_1 y_1' \rangle + \langle y_1 \theta_s \rangle$
 $= \langle y_1 y_1' \rangle + \langle y_1 \rangle \langle \theta_s \rangle = \langle y_1 y_1' \rangle$

So

$$\varepsilon_2 = \frac{\alpha^2}{\beta} \langle y_1'^2 \rangle + 2\alpha \langle y_1 y_1' \rangle + \beta \left(\langle y_1'^2 \rangle + \frac{1}{2} \langle \theta_s^2 \rangle \right)$$

$$= \varepsilon_1 + \frac{\beta}{2} \langle \theta_s^2 \rangle$$

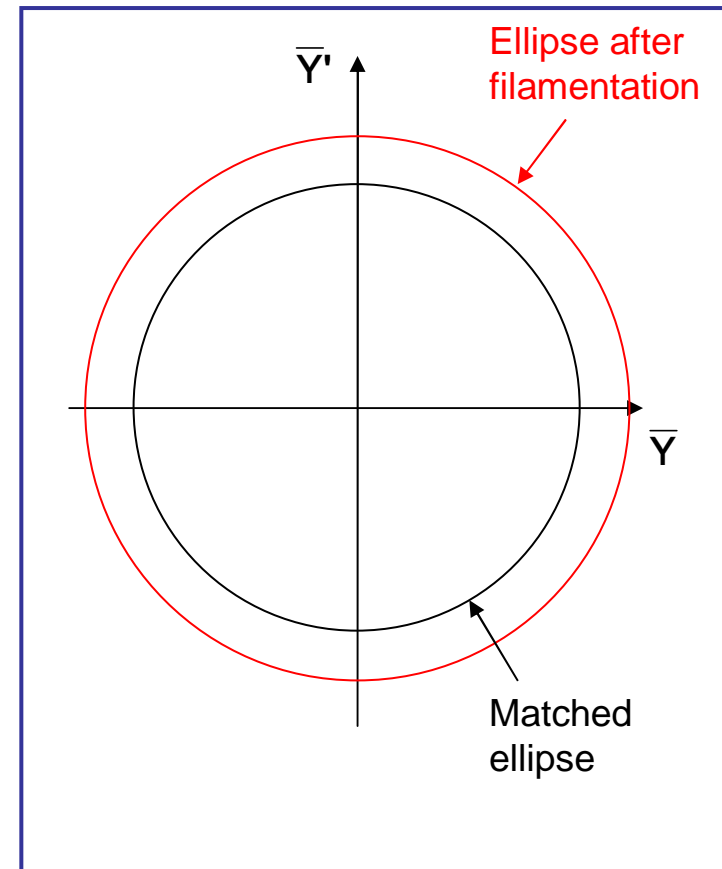

Charge stripping

- For LHC heavy ions, Pb^{53+} is stripped to Pb^{82+} at 4.25 GeV/u using a 0.8 mm thick Al foil, in the PS to SPS line
- $\Delta\varepsilon$ minimised with low- β insertion in the TT2/TT10 transfer line
- Emittance increase expected is about 8%

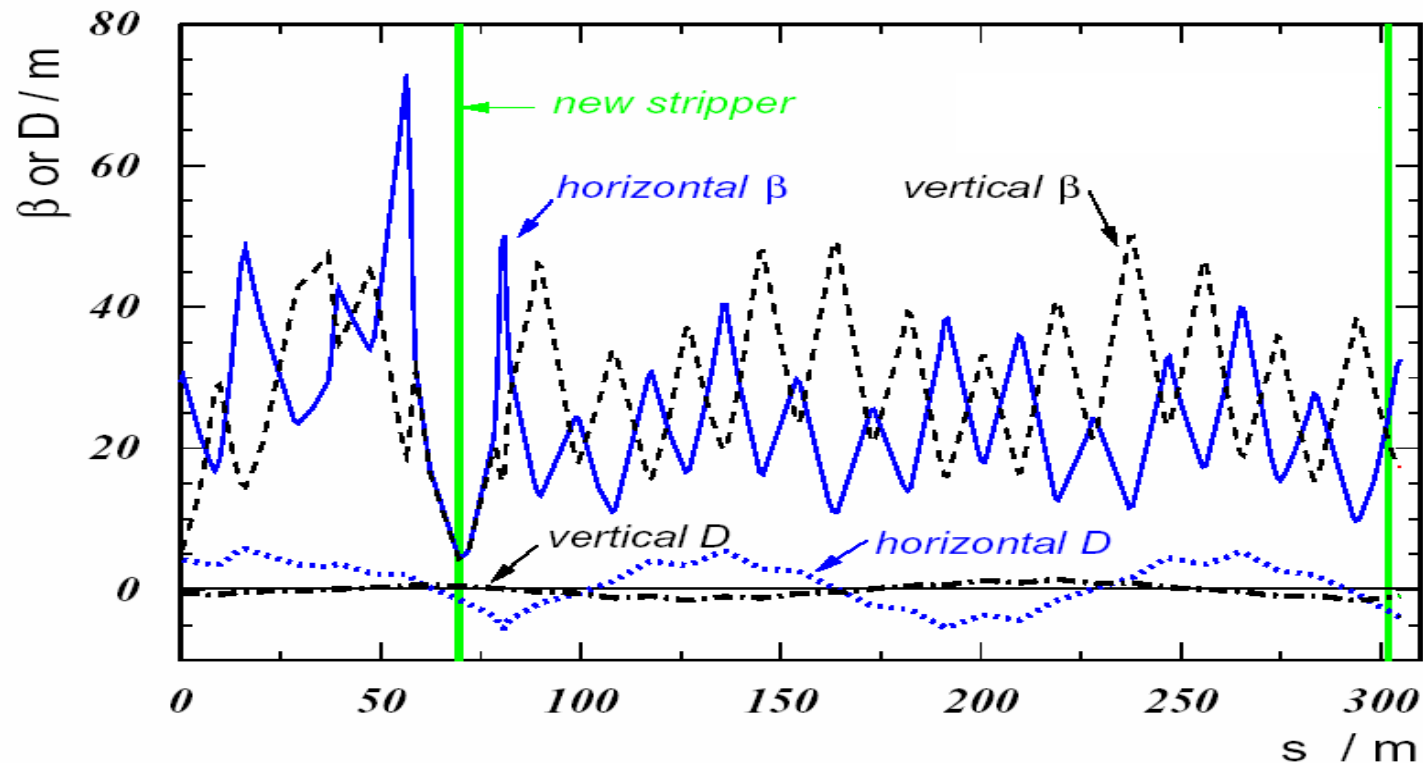

Summary

- Transfer lines present interesting challenges and differences from circular machines
 - No periodic condition mean optics is defined by initial beam ellipse and transfer line lattice
 - Matching at the extremes is non-trivial
 - Special measurement techniques needed
 - Performance criteria include aperture and emittance blow-up