



Superconducting accelerator magnets

Daniel Schoerling
daniel.schoerling@cern.ch
19th of May 2021
CAS@EAS

Thanks to many colleagues, in particular Paolo Ferracin for the material they have given to me

Why colliders?

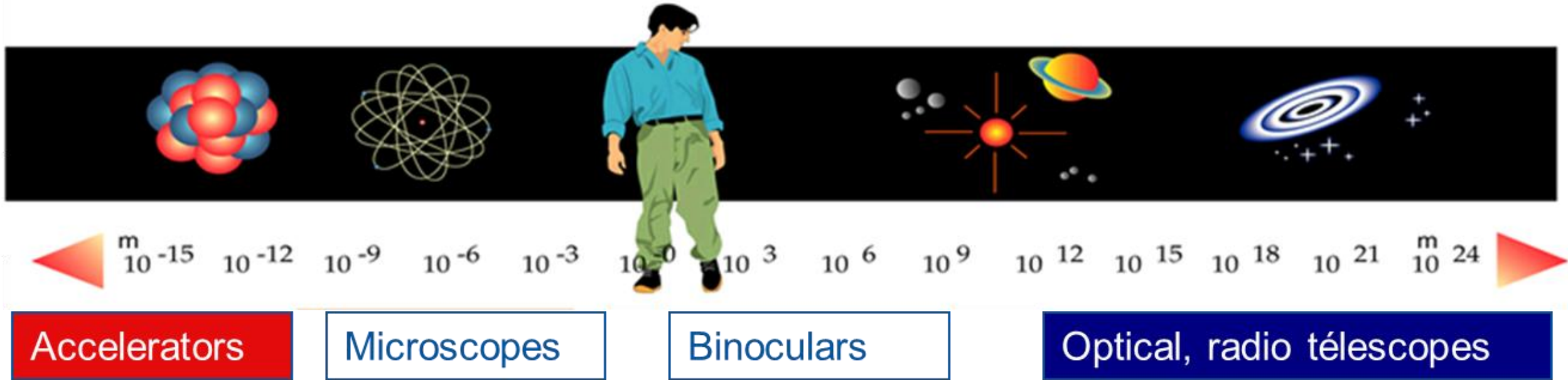

Accelerators are the finest microscopes: *atto-scope or zepto-scope*

$$\lambda = h/p ; \text{ @LHC: } p = 1 \text{ TeV} \Rightarrow \lambda \cong 10^{-18} \text{ m}$$

λ : wavelength

h : Planck constant

p : momentum

Why SC accelerator magnets and where are they used?

COLLIDERS (LEP, Tevatron, Hera, RHIC, LHC, etc.)

- One of the most important parameter of colliders is the beam energy, as it determines the physics discovery potential.

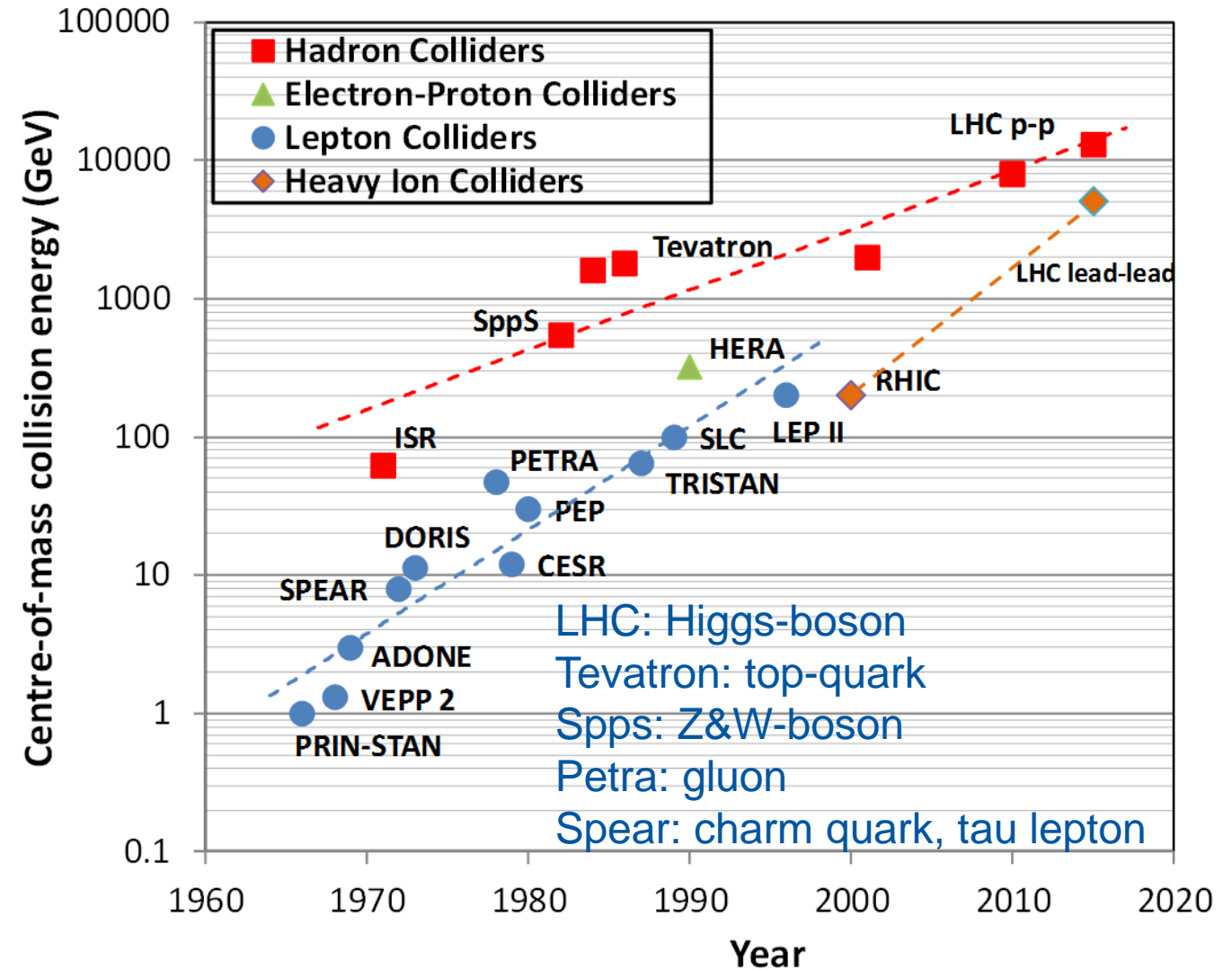

Magnets in accelerators, why?

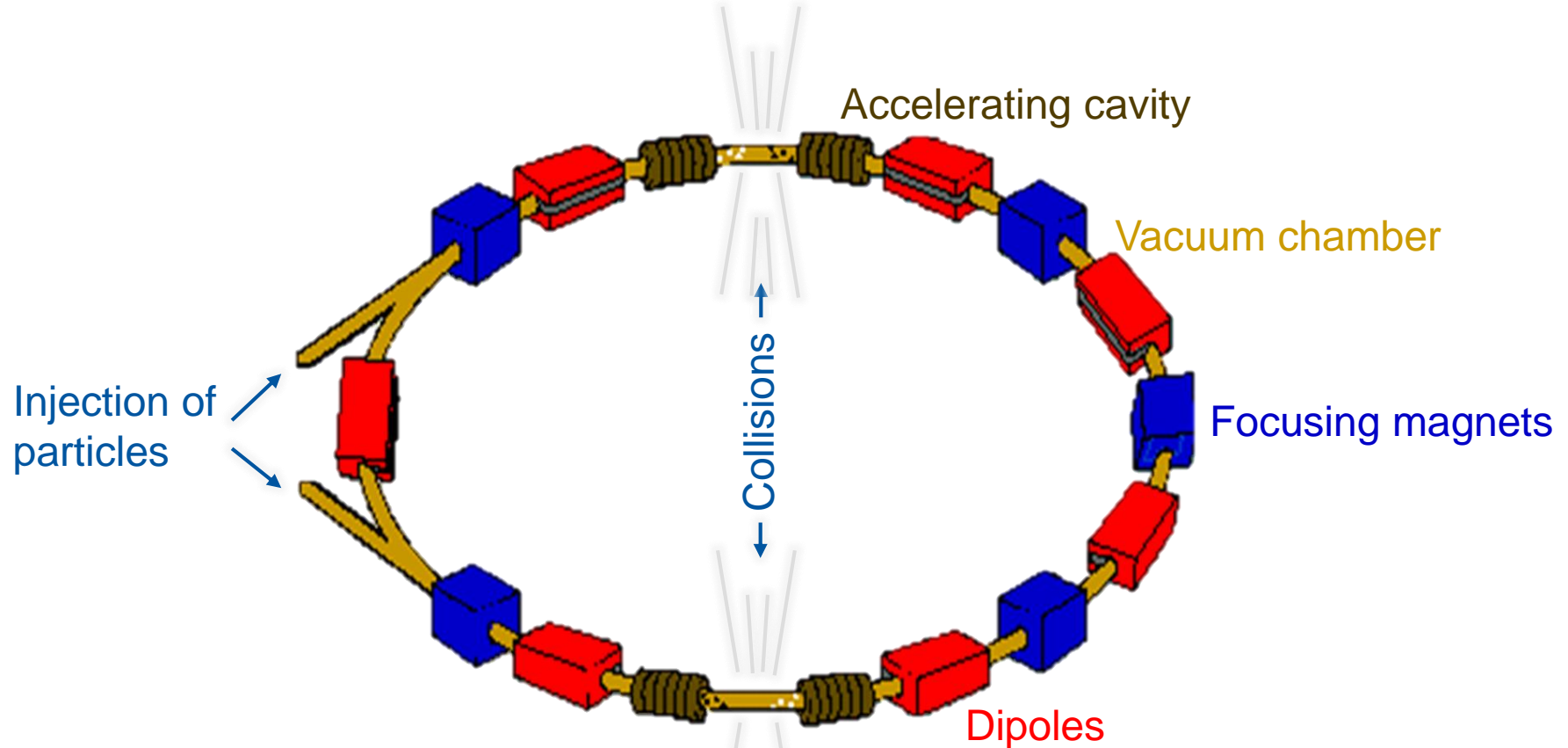

The energy E in GeV of particles in a circular accelerator is limited by the strength of the bending dipole magnets B in Tesla and the machine radius r in m:

$$E \approx 0.3 B r$$

Dipoles

- The magnetic field B steers the particles in a circular orbit:
$$\mathbf{F} = q\mathbf{E} + q\mathbf{v} \times \mathbf{B}$$
- First term ($q\mathbf{E}$) negligible: 300 MV/m corresponds to 1 T

N/I : Ampere turns in A

J : Current density in A/m²

B : Magnetic flux density in T = N/Am

v : velocity in m/s

F : Force in N

ρ : particle path radius in m

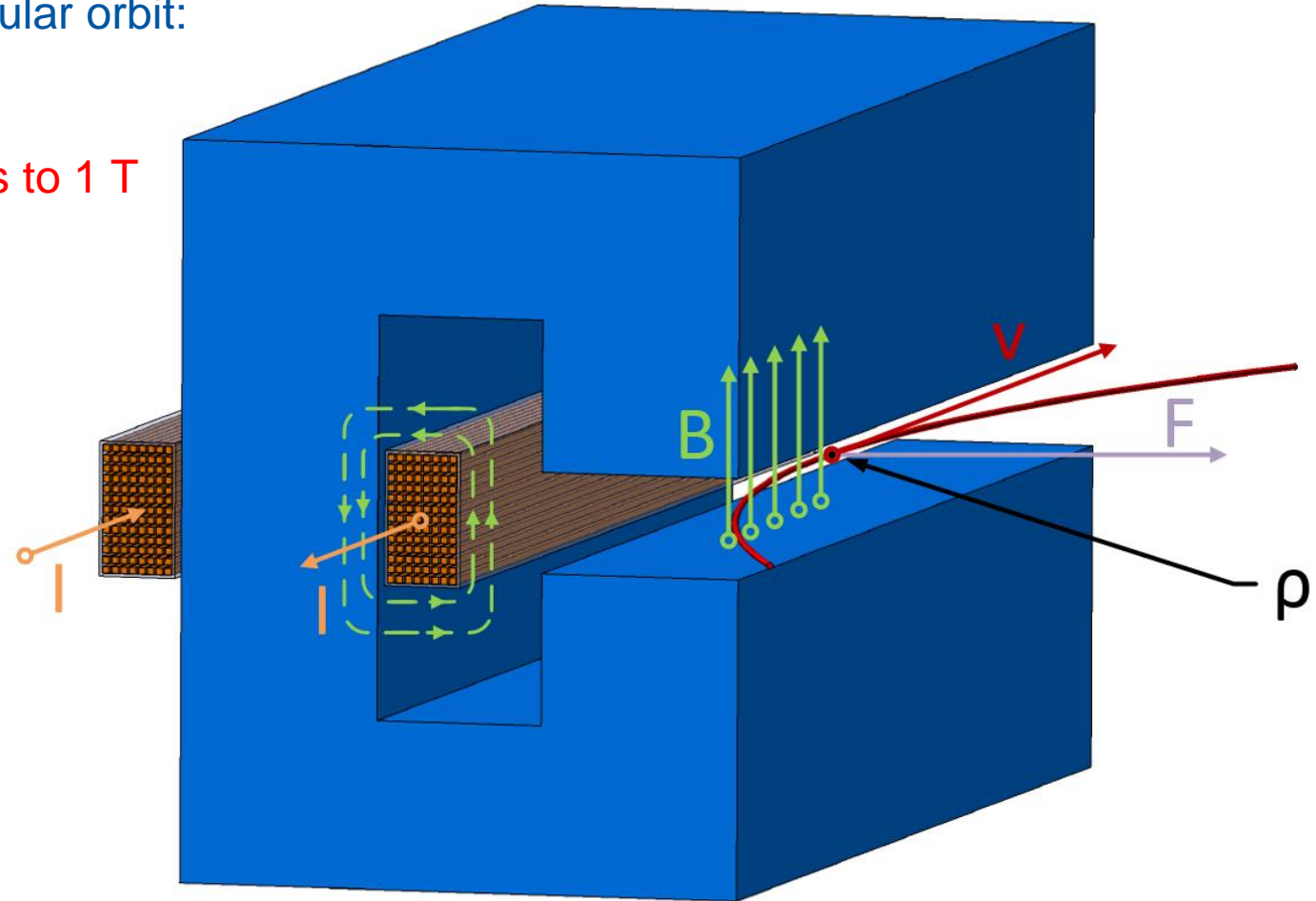

Why SC magnets?

Normal-conducting iron-dominated magnets:

- $B \approx \mu_0 NI / g$
- Limited by the iron saturation: $B \lesssim 2 \text{ T}$
- Ohmic losses, cooling, power converters, etc.

- $g = 100 \text{ mm}$ (gap)
- $NI = 160 \text{ kA}$ (Ampere turns)
- **$B = 2 \text{ T}$ (Magnetic flux density, limit)**

Superconducting magnets:

- $B \approx \mu_0 NI / \pi r$
- Limited only by SC material properties and cost
- Cooling, power converters, busbars

- $r = 1/2g = 45 \text{ mm}$ (aperture radius)
- $NI = 1 \text{ MA}$ (Ampere turns)
- **$B = 8.84 \text{ T}$ (magnetic flux density)**

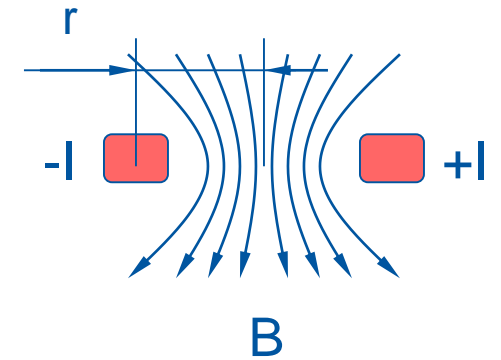
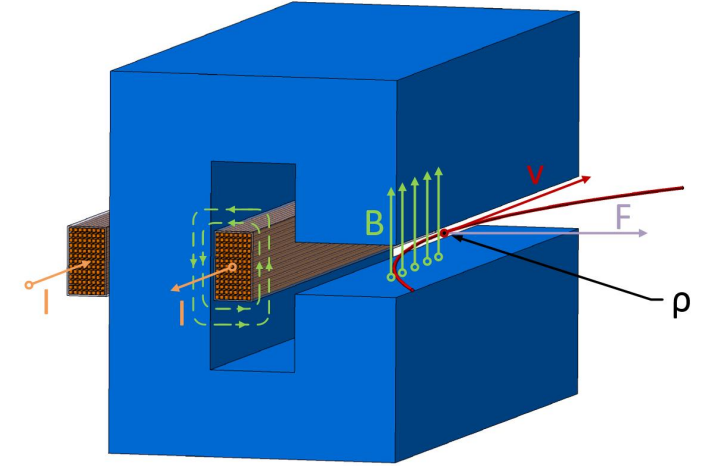

CERN's infrastructure

50 000 tons of normal conducting magnets
50 000 tons of superconducting magnets

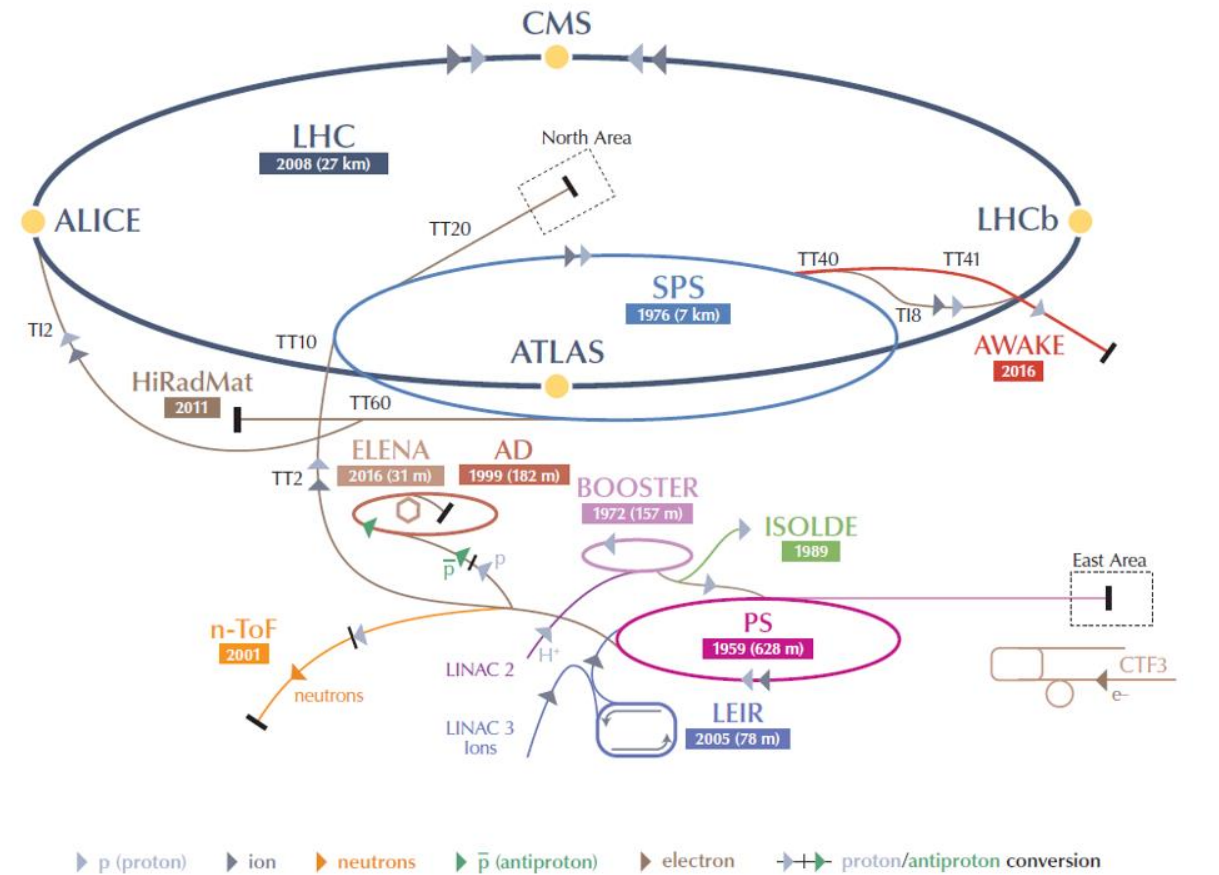

LHC Large Hadron Collider SPS Super Proton Synchrotron PS Proton Synchrotron
 AD Antiproton Decelerator CTF3 Clic Test Facility AWAKE Advanced WAKEfield Experiment ISOLDE Isotope Separator OnLine DEvice
 LEIR Low Energy Ion Ring LINAC LINear ACcelerator n-ToF Neutrons Time Of Flight HiRadMat High-Radiation to Materials

The LHC dipole magnet

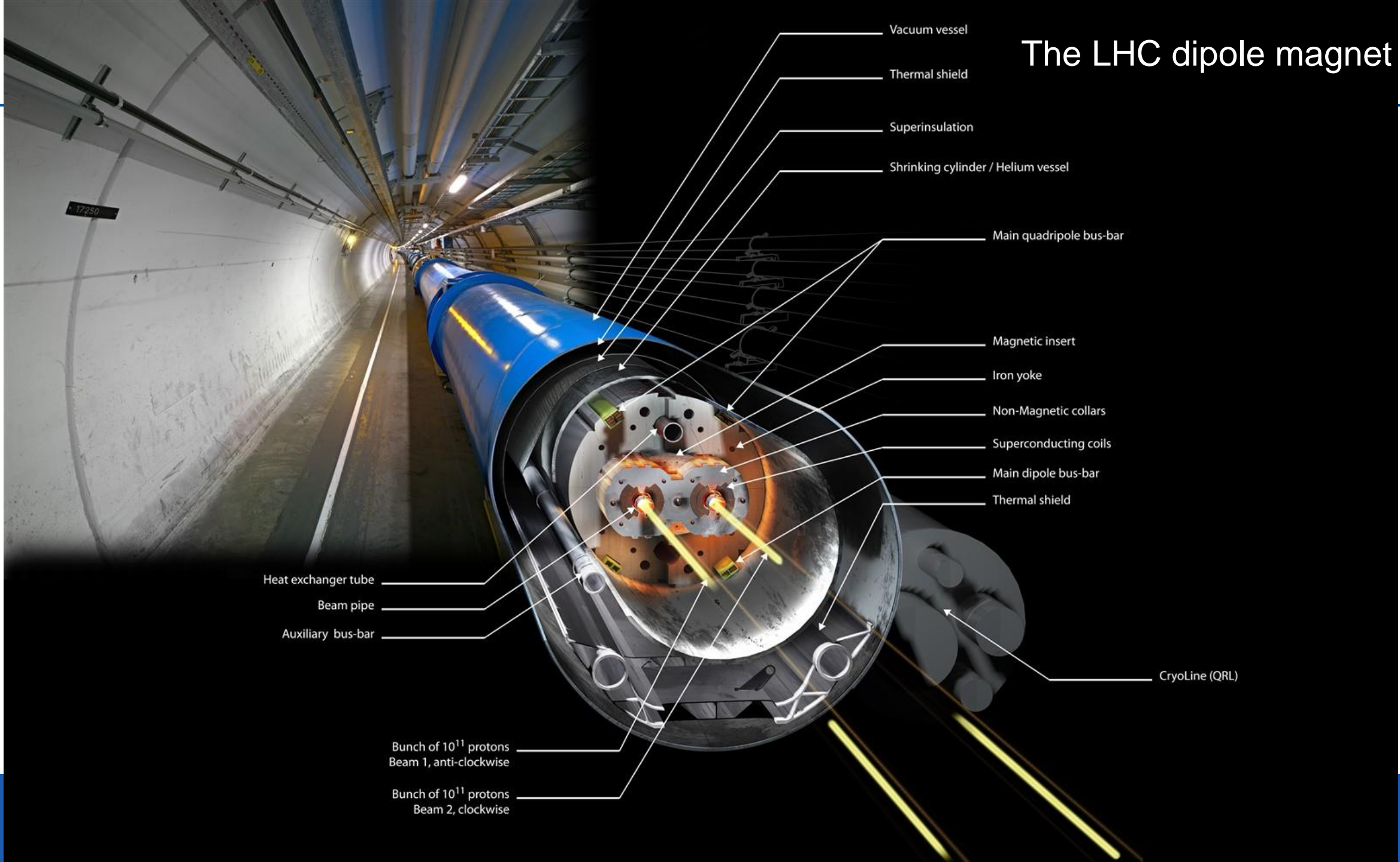

Vacuum vessel

Thermal shield

Superinsulation

Shrinking cylinder / Helium vessel

Main quadrupole bus-bar

Magnetic insert

Iron yoke

Non-Magnetic collars

Superconducting coils

Main dipole bus-bar

Thermal shield

CryoLine (QRL)

Heat exchanger tube

Beam pipe

Auxiliary bus-bar

Bunch of 10^{11} protons
Beam 1, anti-clockwise

Bunch of 10^{11} protons
Beam 2, clockwise

In which domains do we need to work?

Multidisciplinary field:

- Chemistry and material science: superconducting materials
- Quantum physics: the key mechanisms of superconductivity
- Classical electrodynamics: magnet design
- Mechanical engineering: support structures
- Electrical engineering: powering of the magnets
- Cryogenics: keep them cool ...
- Industrialization & large and complex project management
- Cost modelling
- Impact on society

Very different fields and multi-disciplinary field not limited to physics and engineering

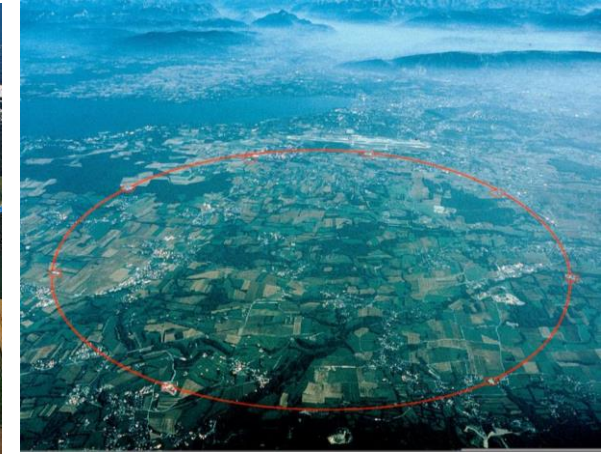
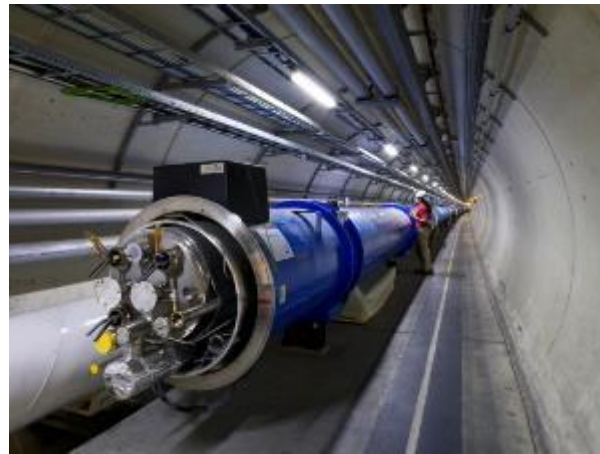
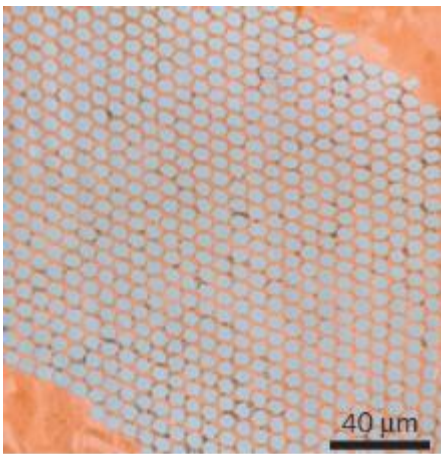

What do we need to do to get a good design?

Let's focus on the main (technical) points:

- Conductor and cable design, which superconducting material, strand and cable to choose?
- How to do the electromagnetic and structural design of the coil (field and field quality load line margin, quench)?

AIM OF LECTURE: Understand the main technical concepts relevant in superconducting accelerator magnets!

Superconducting material

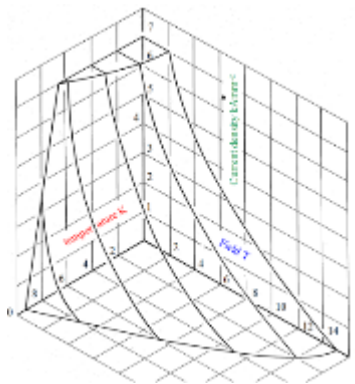

Superconducting strand

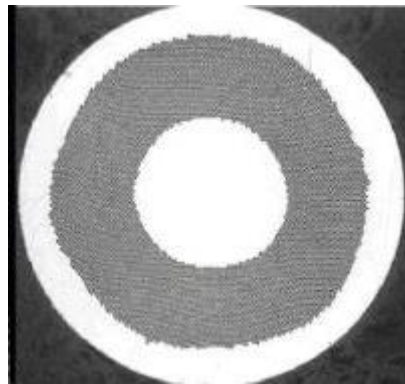

Superconducting cable



Superconducting coil



Superconducting magnet

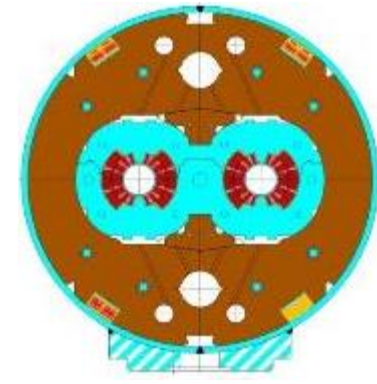

Superconducting material

- Superconductivity discovered in 1911 by Kammerlingh-Onnes: ZERO resistance of mercury wire at 4.2 K
- Temperature at which the transition takes place: critical temperature T_c
- Observed in many materials: but not in the typical best conductors (Cu, Ag, Au)

Kammerlingh-Onnes proposed 1913 a 10 T solenoid, but it took 50 years (!) of hard work to make this dream come true

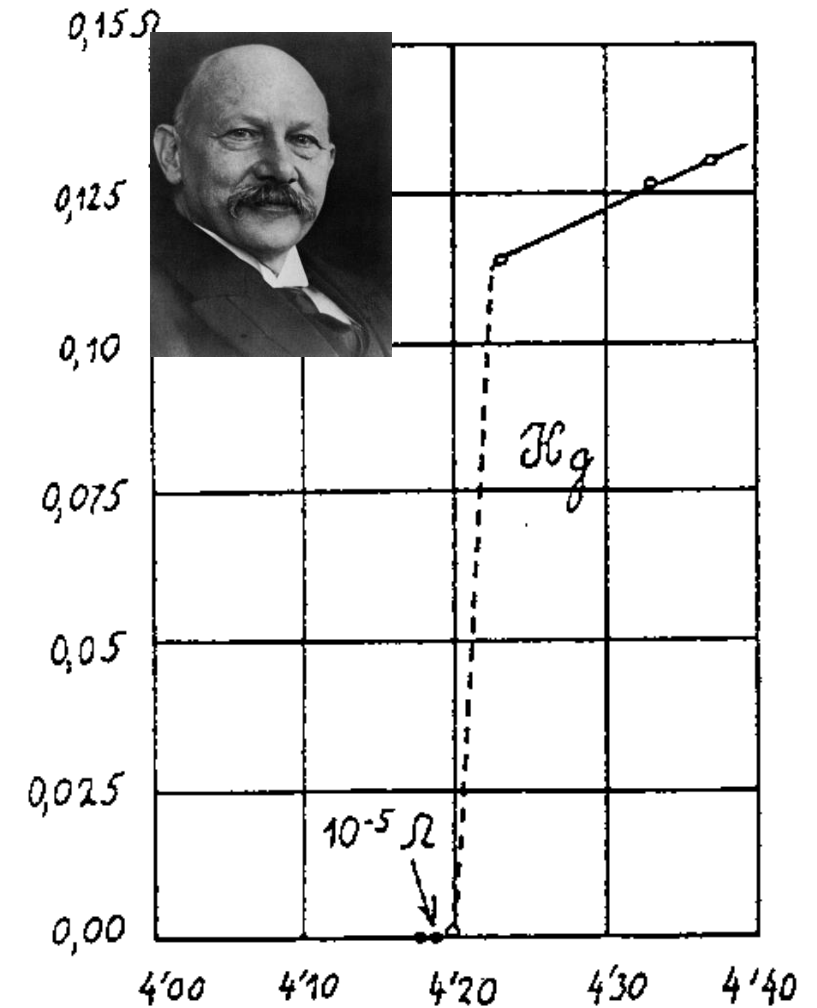

Superconductivity – Type I superconductors

Meissner-Ochsenfeld effect (1933):

- Perfect diamagnetism: With $T < T_c$ magnetic field is expelled
- No magnetic field inside the superconductor → no transport current inside a round conductor

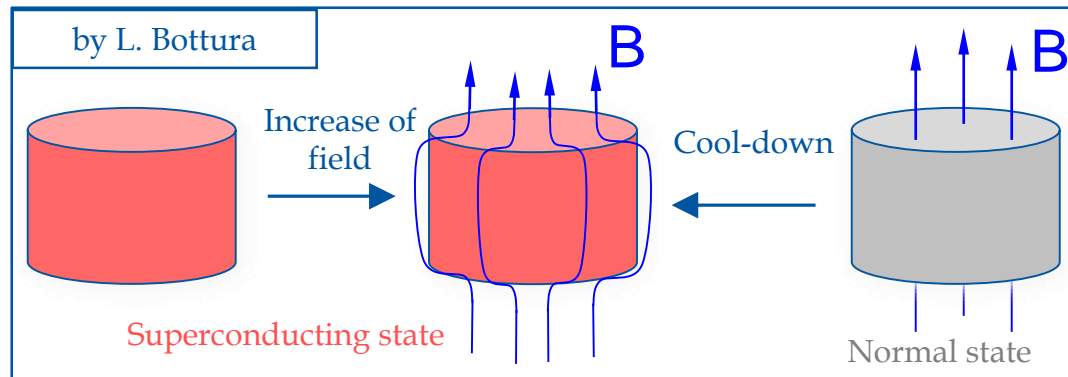

Material	T_c (K)	$\mu_0 H_0$ (mT)
Aluminum	1.2	9.9
Cadmium	0.52	3.0
Gallium	1.1	5.1
Indium	3.4	27.6
Iridium	0.11	1.6
Lanthanum α	4.8	
β	4.9	
Lead	7.2	80.3
Lutecium	0.1	35.0
Mercury α	4.2	41.3
β	4.0	34.0
Molybdenum	0.9	
Osmium	0.7	~ 6.3
Rhenium	1.7	20.1
Rhodium	0.0003	4.9
Ruthenium	0.5	6.6
Tantalum	4.5	83.0
Thalium	2.4	17.1
Thorium	1.4	16.2
Tin	3.7	30.6
Titanium	0.4	
Tungsten	0.016	0.12
Uranium α	0.6	
β	1.8	
Zinc	0.9	5.3
Zirconium	0.8	4.7

Superconductivity – Type II superconductors

- So, for 40-50 years, superconductivity was a research activity
- Then, in the 50's, type II superconductors were discovered:
 - Between B_{c1} and B_{c2} : mixed phase
 - B penetrates as flux tubes: fluxoids with a flux of $\phi_0 = h/2e = 2 \cdot 10^{-15}$ Wb
- Much higher fields and link between T_c and B_{c2}

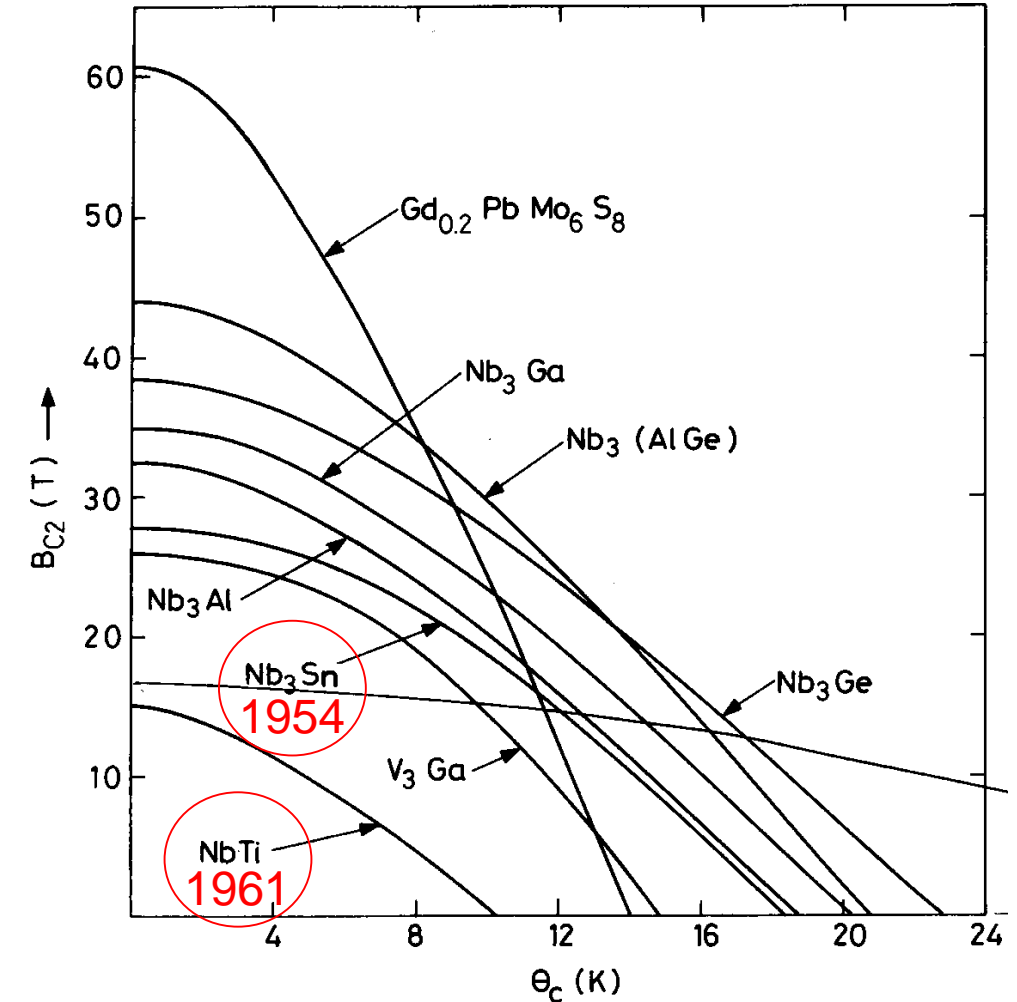
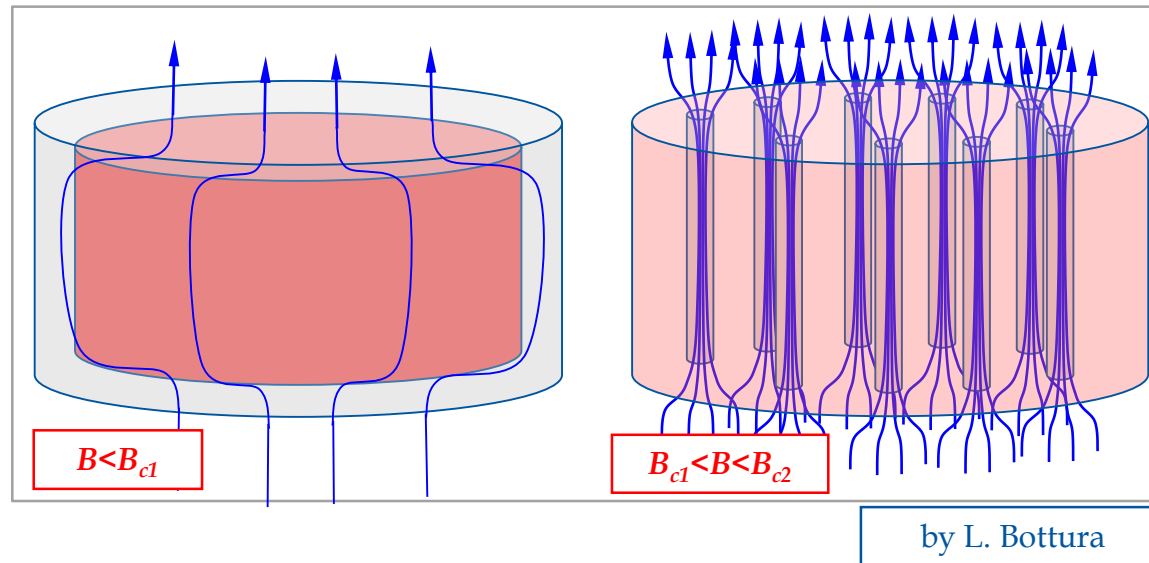

Superconductivity – Hard superconductors

- ...but, if a current passes through the tubes
 - Lorentz force on the fluxoids: $f = J \times B$
- The force causes a motion of tubes
 - Flux motion (dB/dt) → energy dissipation
- Fluxoids must be locked by pinning centres
 - Defects or impurities in the structure

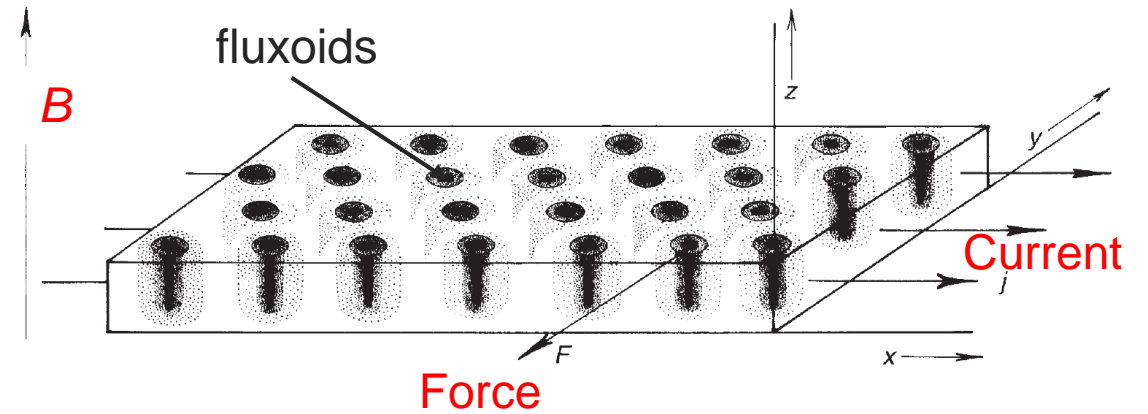

- The pinning centres exert a pinning force as long as $f \leq J \times B$:
- No flux motions → no dissipation
- J_c is the current density at which, for a given B and at a given T the pinning force is exceeded by the Lorentz force

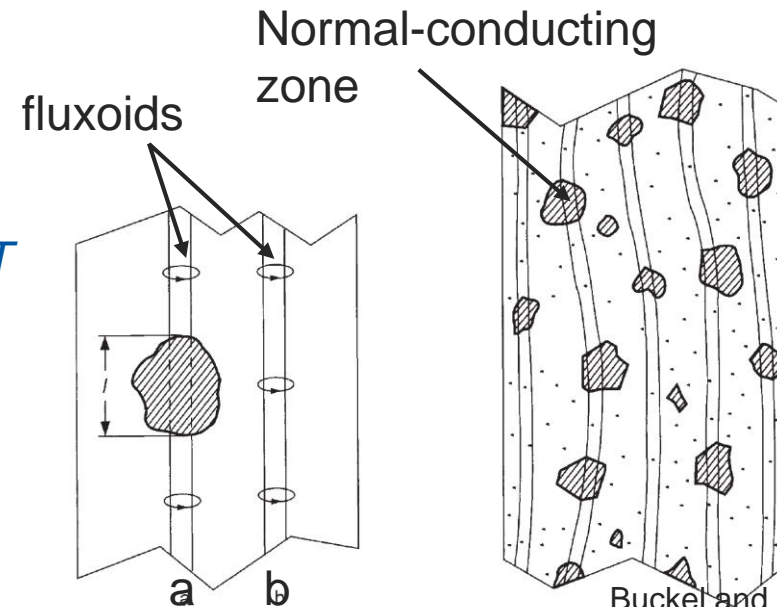

Buckel and Kleiner: Superconductivity

Superconductivity – Critical surface

A type II material is superconductor below the critical surface defined by

- Critical temperature T_c (property of the material)
- Upper critical field B_{c2} (property of the material)
- Critical current density J_c (property of the material but in practice hard work by the producer)

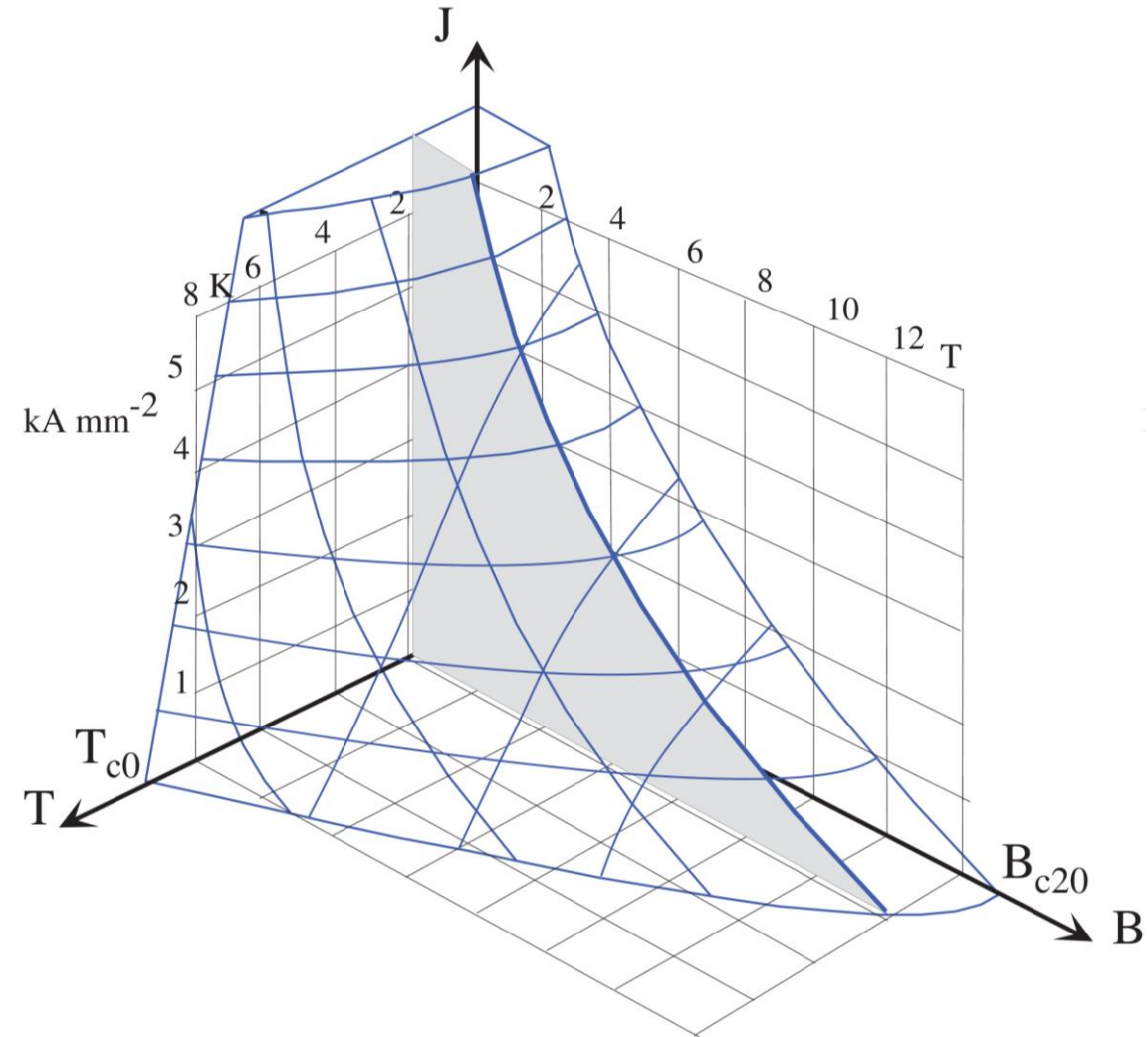

Technical superconductors: Nb-Ti (1961) and Nb₃Sn (1954)

- Nb and Ti: ductile alloy
 - Production route: Extrusion + drawing
 - T_c is ~9.2 K at 0 T
 - B_{c2} is ~14.5 T at 0 K
 - Firstly in Tevatron (80s), then in HERA, RHIC and LHC
 - ~50-200 US\$ per kg of wire (1 euro per m)
- Nb and Sn → intermetallic compound
 - Brittle, strain sensitive, formed at ~650-700°C
 - T_c is ~18 K at 0 T
 - B_{c2} is ~28 T at 0 K
 - Used in NMR, ITER, HL-LHC and baseline for FCC
 - ~700-1500 US\$ per kg of wire (target price for FCC: 500 US\$ per kg of wire)

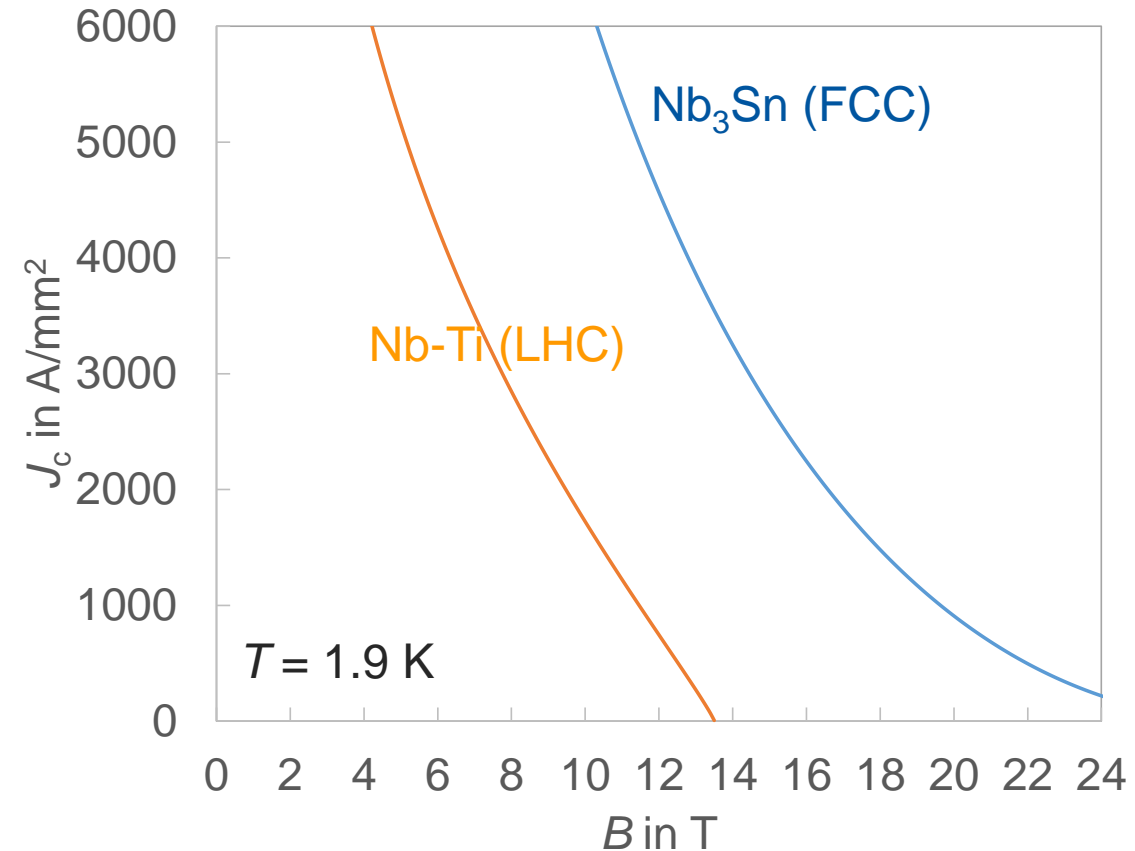

Conductors: from Cu to Nb₃Sn

0.85 mm diameter strand

Cu

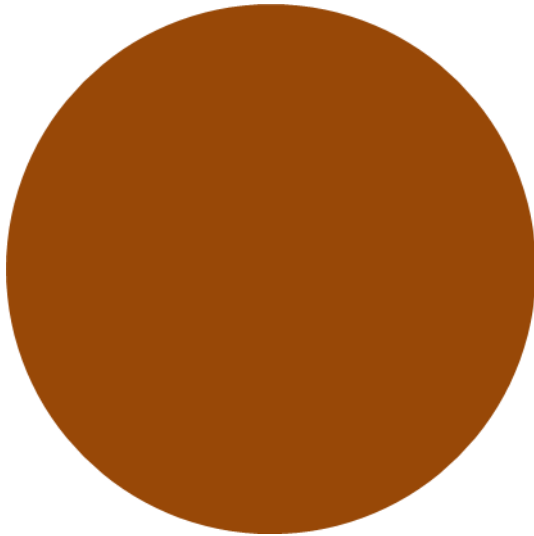

$$J_e \sim 5 \text{ A/mm}^2$$

$$I \sim 3 \text{ A}$$

$$B = 2 \text{ T}$$

Nb-Ti

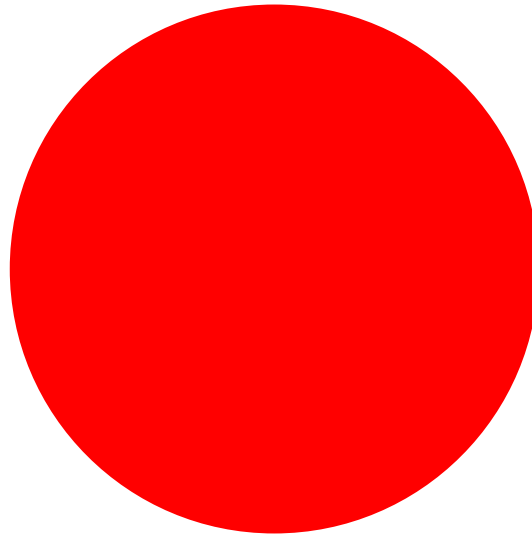

$$J_e \sim 600\text{-}700 \text{ A/mm}^2$$

$$I \sim 300\text{-}400 \text{ A}$$

$$B = 8\text{-}9 \text{ T}$$

Nb₃Sn

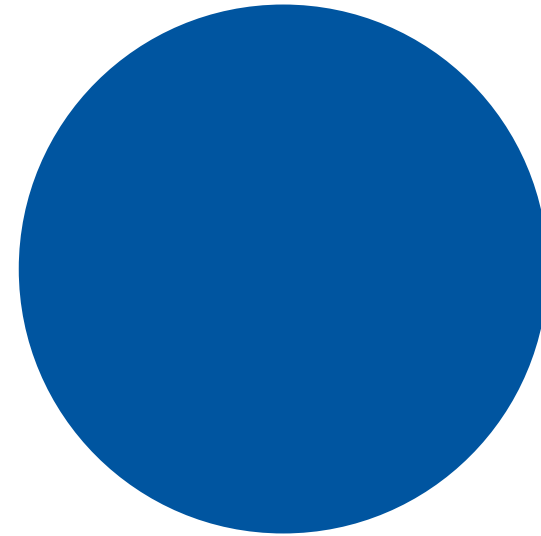

$$J_e \sim 600\text{-}700 \text{ A/mm}^2$$

$$I \sim 300\text{-}400 \text{ A}$$

$$B = 12\text{-}16 \text{ T}$$

Conductors: from Cu to Nb₃Sn

0.85 mm diameter strand

Cu

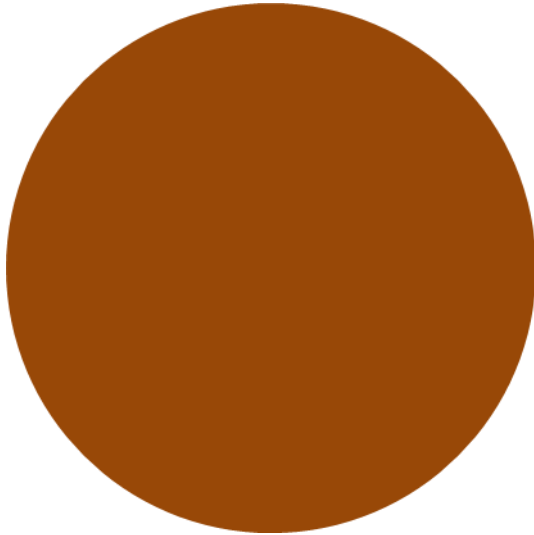

$$J_e \sim 5 \text{ A/mm}^2$$

$$I \sim 3 \text{ A}$$

$$B = 2 \text{ T}$$

Nb-Ti

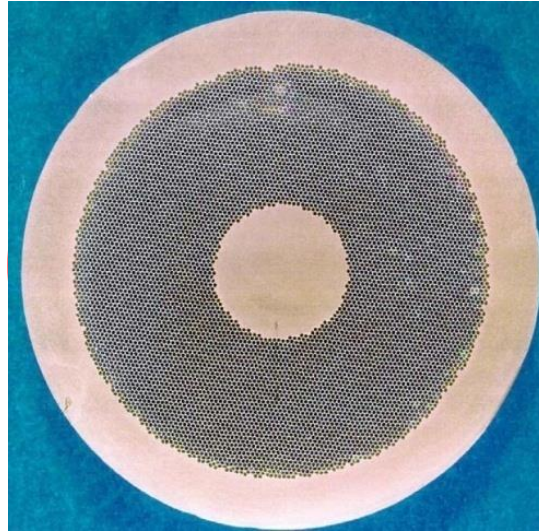

$$J_e \sim 600\text{-}700 \text{ A/mm}^2$$

$$I \sim 300\text{-}400 \text{ A}$$

$$B = 8\text{-}9 \text{ T}$$

Nb₃Sn

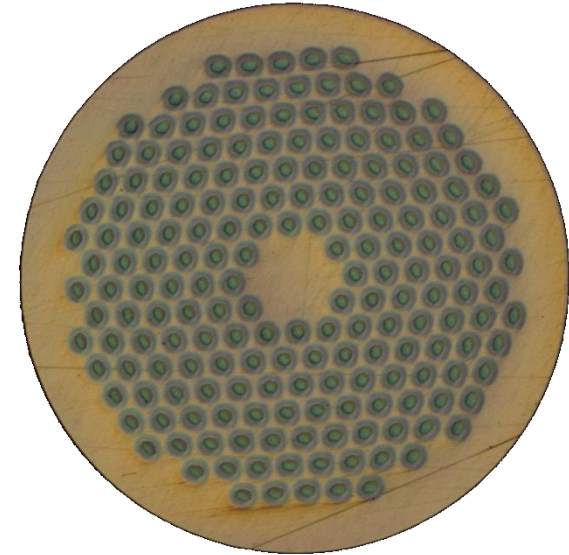

$$J_e \sim 600\text{-}700 \text{ A/mm}^2$$

$$I \sim 300\text{-}400 \text{ A}$$

$$B = 12\text{-}16 \text{ T}$$

Why small filaments? Stability!

- Simple model: SC carries either J_c or no current \rightarrow If field is changed, eddy currents are resistively damped
- The conductor is stable as long as temperature stays below the critical temperature T_c

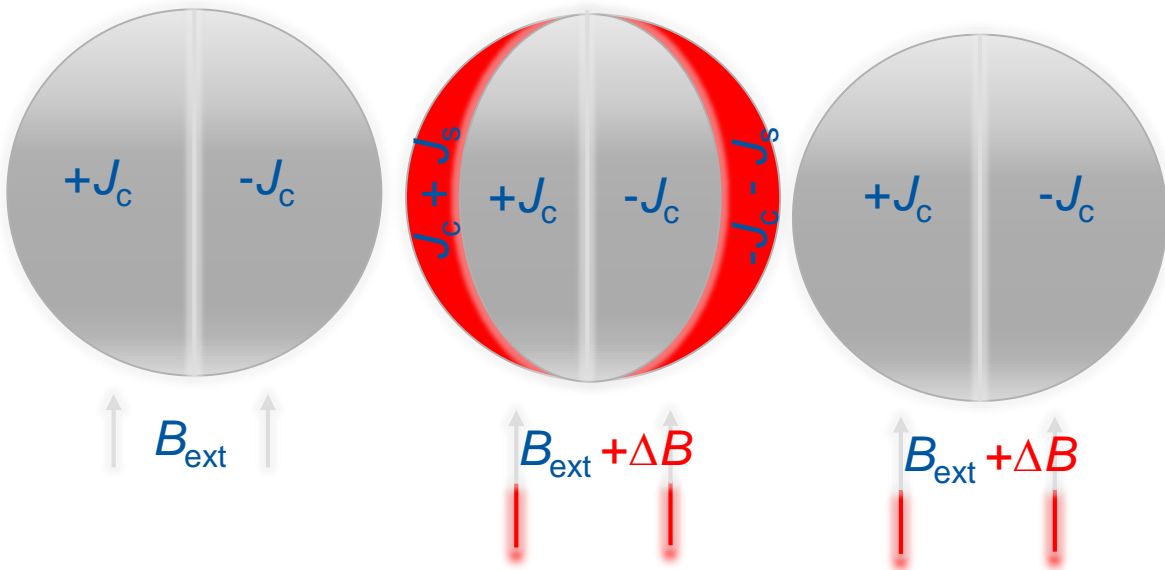

One large filament	Several ($N \gg 1$) small filaments
same SC area, i.e. $a_L^2 = Na_S^2$	
total volumetric heat [J/m ³]	
$Q_L \approx \frac{8\Delta B}{3\pi} J_c a_L$	$Q_S \approx \frac{8\Delta B}{3\pi} J_c a_S$

$$\frac{Q_S}{Q_L} = \frac{a_S}{a_L} = \frac{a_S}{a_S \sqrt{N}} \text{ for } N = 100 \quad \frac{Q_S}{Q_L} = \frac{1}{10}$$

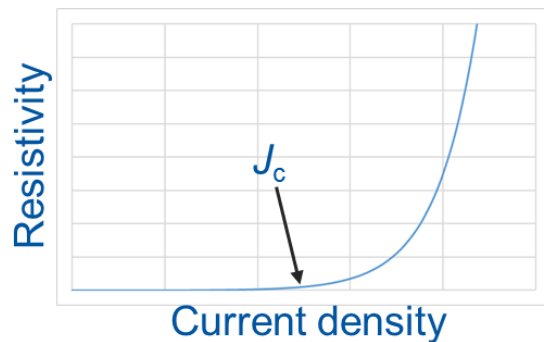

$$a \leq \sqrt{\frac{3\gamma C(\theta_c - \theta_0)}{\mu_0 j_c^2}}$$

Why Cu? Stability & Protection!

Quench protection

- Superconductors have a very high normal state resistivity
- If quenched, could reach very high temperatures in few ms
- If embedded in a high-purity copper matrix, when a quench occurs, current redistributes in the low-resistivity matrix yielding to a lower peak temperature

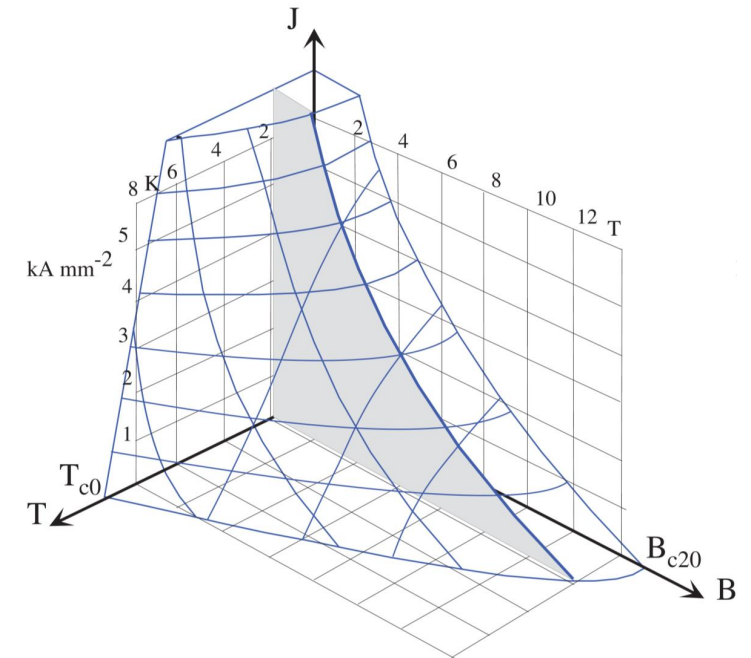
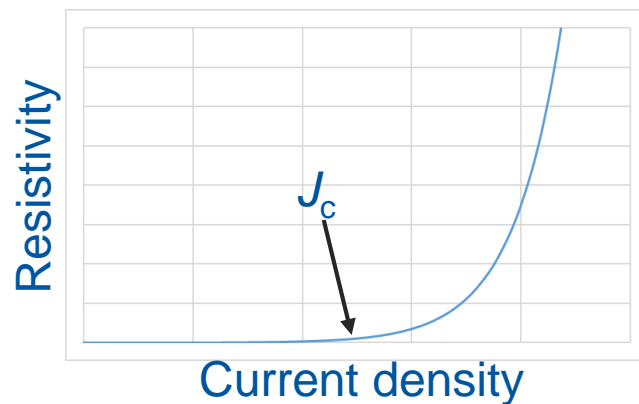
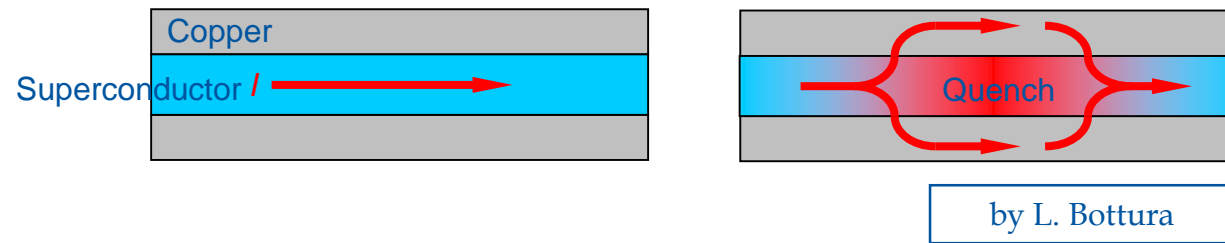

What about AC losses? Twisting!

Twisting

- When a multi-filamentary wire is subjected to a time varying magnetic field, current loops are generated between filaments.
- If filaments are straight, large loops with large currents \rightarrow AC losses
- If the strands are magnetically coupled the effective filament size is larger \rightarrow flux jumps

To reduce these effects, filaments are twisted, the twist pitch is of the order of 20-30 times of the wire diameter.

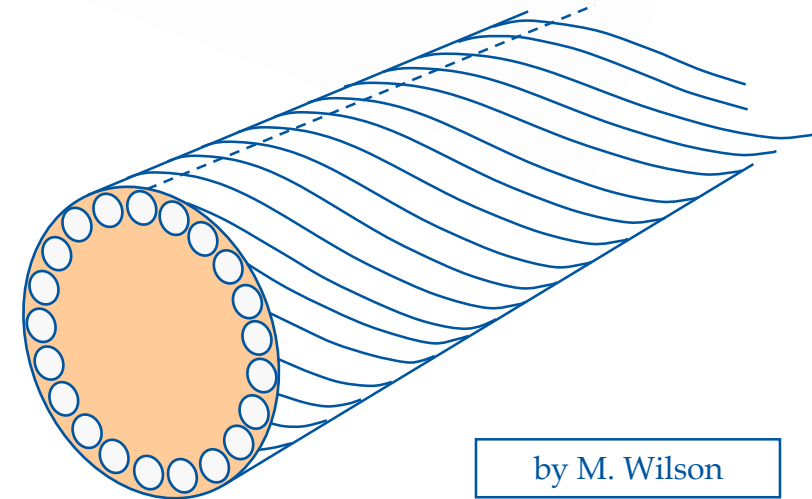
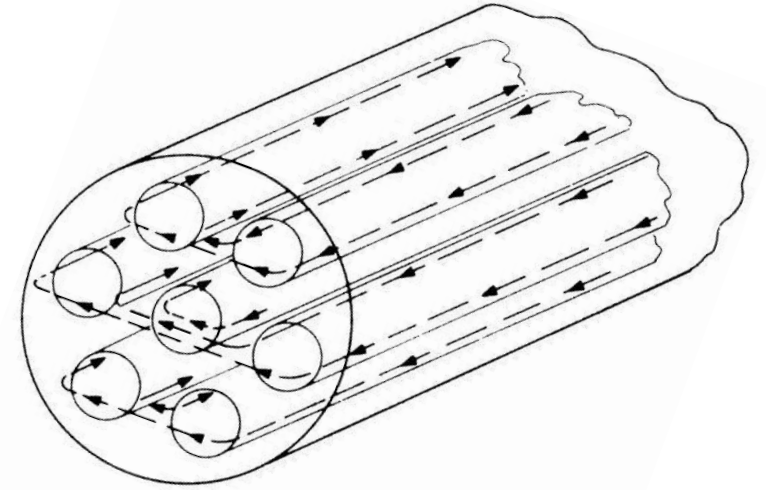

by M. Wilson

And magnetization

Superconductor magnetization

- A hard superconducting filament shows a magnetization curve, as the one shown on the right
- The magnetization stays constant (if no flux jumps occur) at constant field: persistent current
- Field persistent currents produce field errors proportional to J_c and filament diameter
 - HERA filament diameter $14\ \mu\text{m}$
 - LHC filament diameter $6\text{-}7\ \mu\text{m}$
 - HL-LHC filament diameter $50\ \mu\text{m}$
 - FCC target filament diameter $20\ \mu\text{m}$

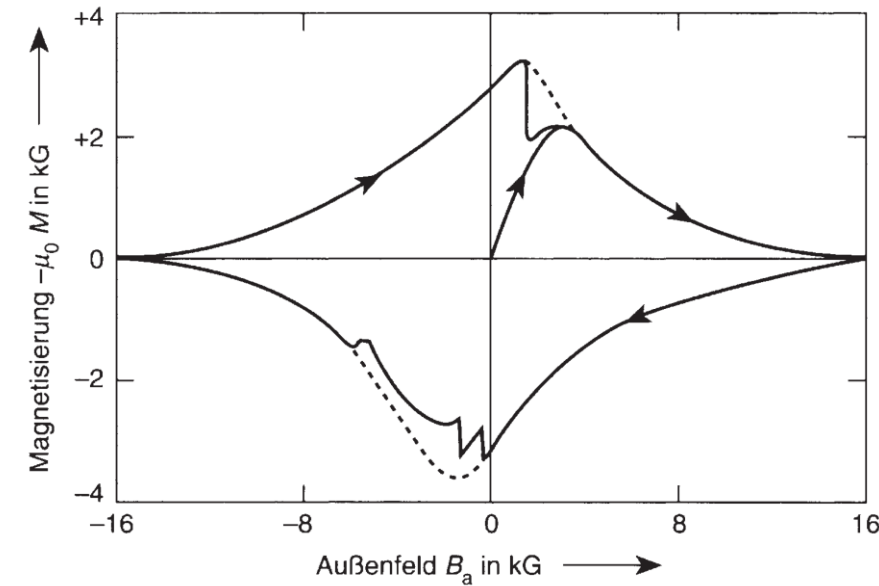

Practical superconductors: Fabrication of Nb-Ti multifilament wires

- Nb-Ti ingots
- 200 mm \varnothing , 750 mm long
- Monofilament rods are stacked to form a multifilament billet, then extruded and drawn down
- Can be re-stacked: double-stacking process

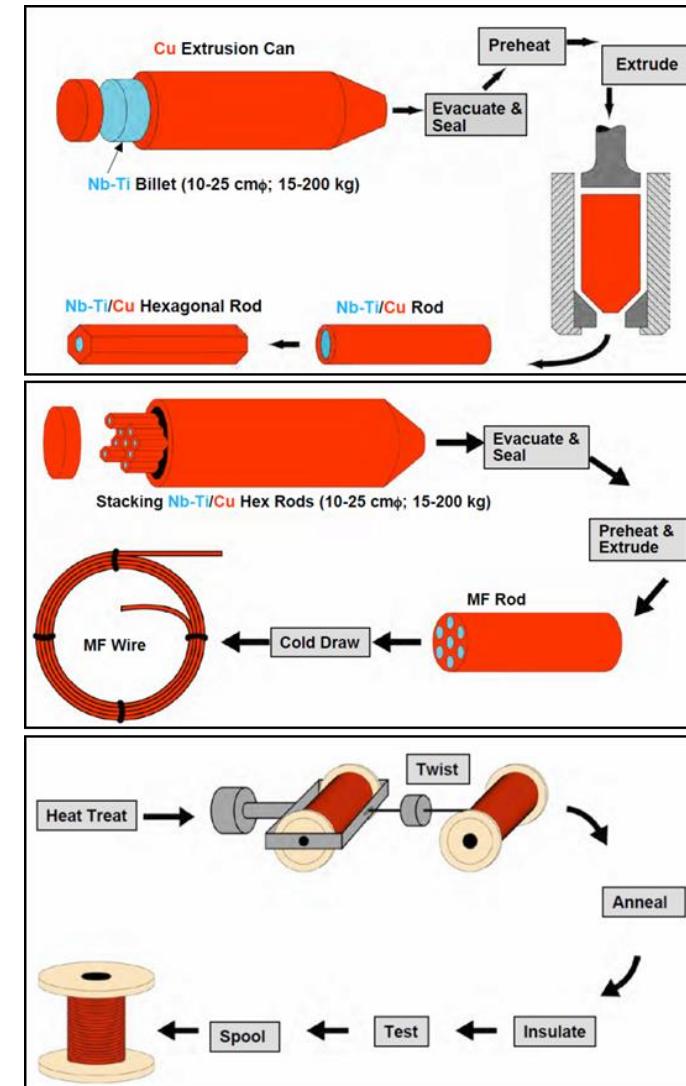
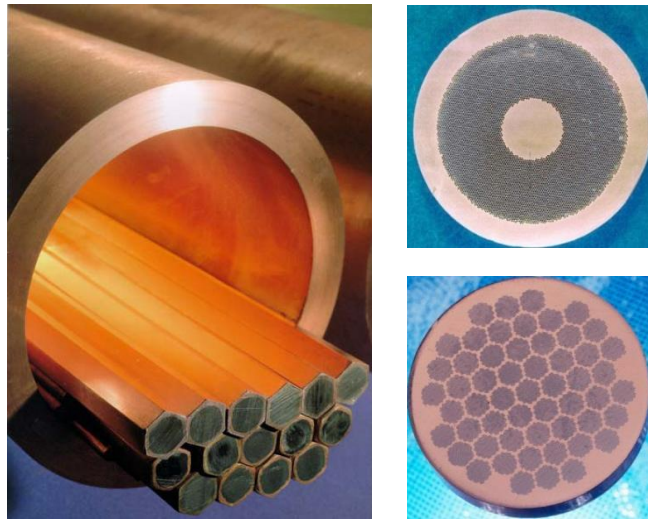

Practical superconductors: Fabrication of Nb₃Sn multifilament wires

- Since Nb₃Sn is brittle it cannot be extruded and drawn like Nb-Ti.
- Process in several steps
 - Assembly multifilament billets from with Nb and Sn separated
 - Fabrication of the wire through extrusion-drawing
 - Fabrication of the cable
 - Fabrication of the coil
- Reaction
 - Sn and Nb are heated to 600-700°C
 - Sn diffuses in Nb and reacts to form Nb₃Sn

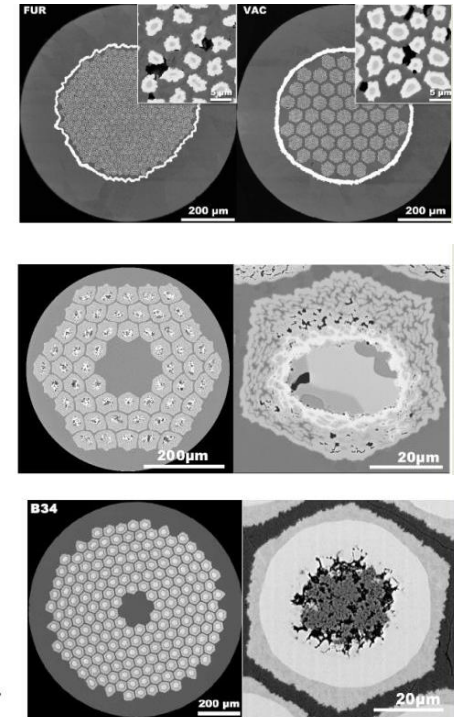
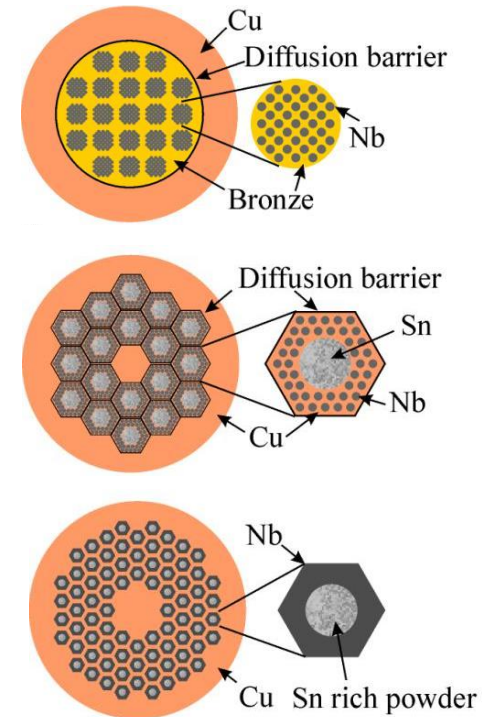

by A. Godeke

Conductors: Strand and cables

- Now, we know we need conductors composed out of small filaments and surrounded by a stabilizer (typically copper) to form a multi-filament wire or strand.
- To keep voltages reasonable small, the inductance of the magnet has to be small $\rightarrow L \propto 1/l^2 \rightarrow$ we need large currents!
- Large wires are excluded due to self-field instabilities yielding to flux jumps (same argument as for small filaments) \rightarrow practical limit 1-2 mm

Solution: Superconducting cable composed of several wires: multi-strand cable!

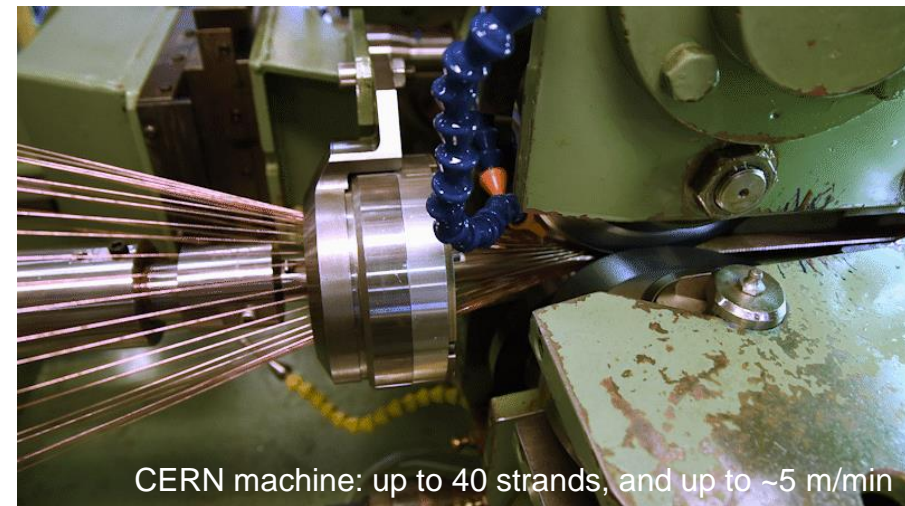
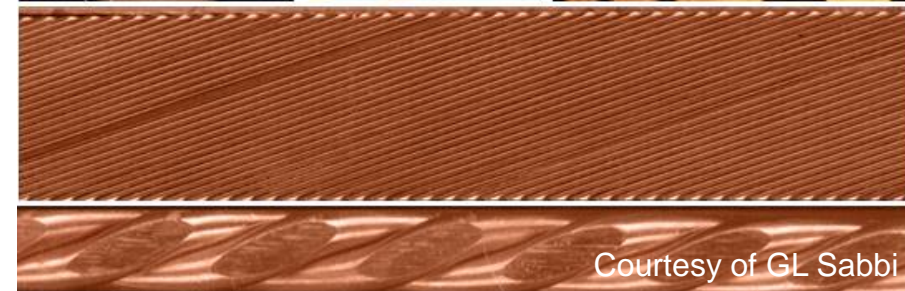
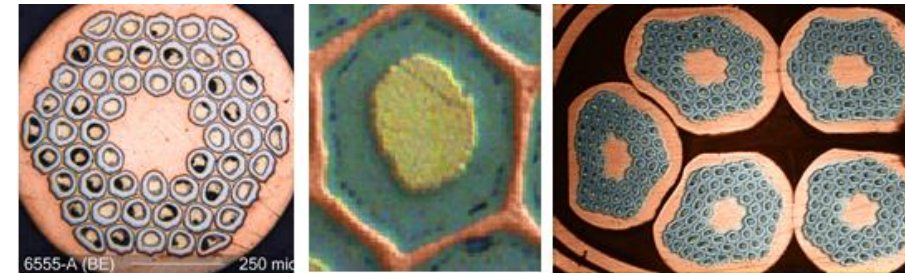

What else do we need? Insulation!

Rule in accelerator magnets: never sacrifice the insulation!



Courtesy of A. Siemko, CERN

Typical insulation schemes for Nb-Ti and Nb₃Sn

Typically the insulation thicknesses: 100 and 200 μm

- The cable insulation must feature good electrical properties to withstand turn-to-turn V after a quench
- Good mechanical properties to withstand high pressure conditions
- Porosity to allow penetration of helium (or epoxy)
- Radiation hardness

In Nb-Ti magnets overlapped layers of polyimide

In Nb₃Sn magnets, fibre-glass braided or as tape/sleeve.

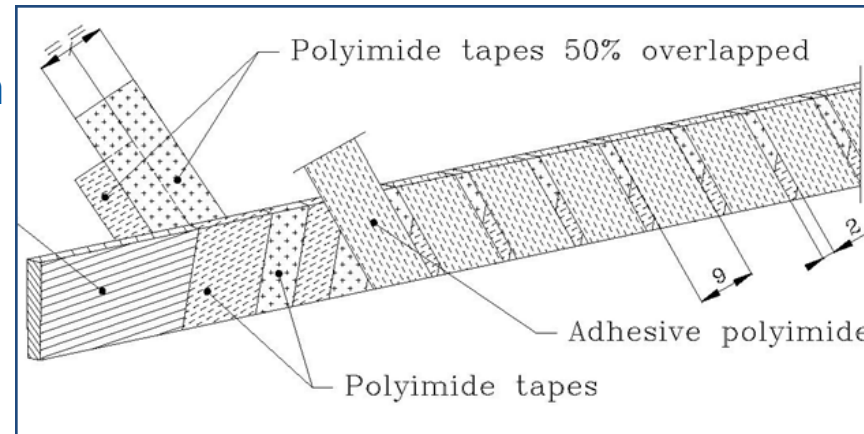

Nb-Ti



Nb₃Sn

Let's take the cable and do an electromagnetic design!

- How do we express field and its “imperfections”?
- How do we create a perfect field?
- How do we design a coil to minimize field errors?
- How do we select the current density in the coil?

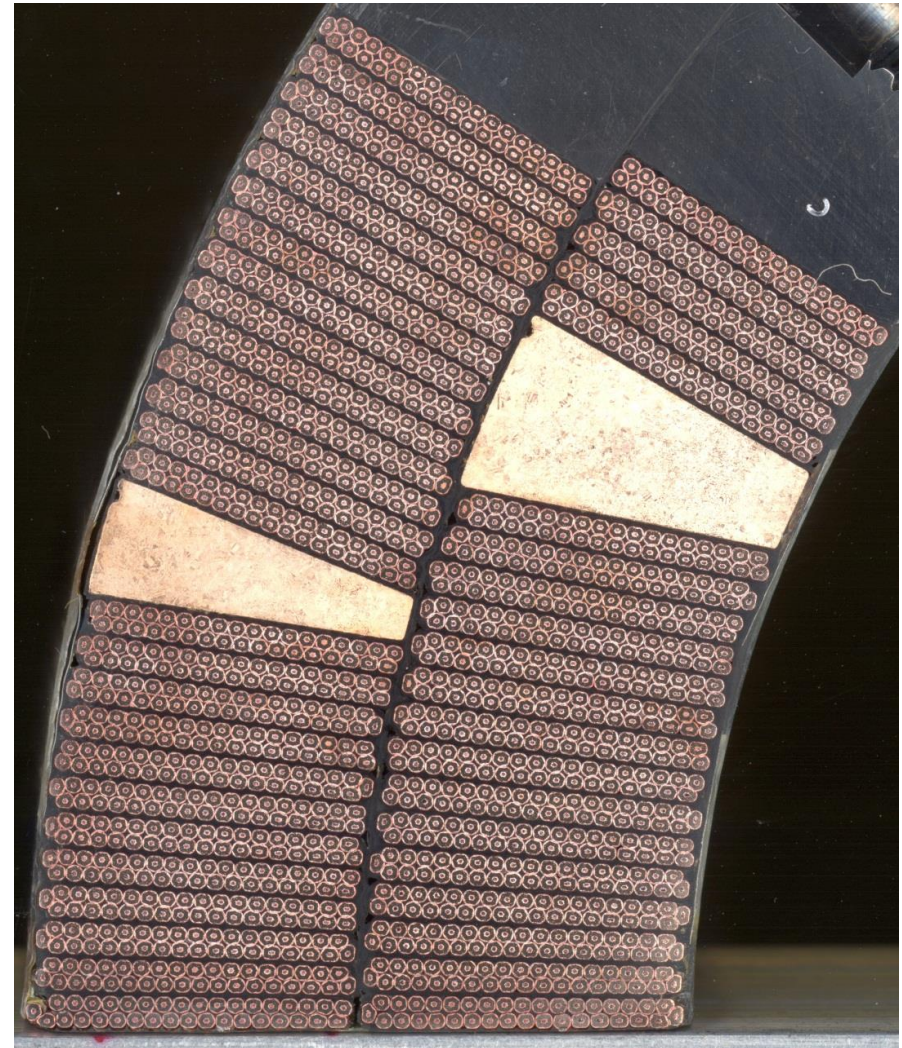

How do we generate a perfect dipole?

- How to generate a dipolar field:
 - Two infinite slabs
 - Two intersection cylinders
 - Cos-theta current distribution
- Many different winding schemes typically classified as
 - Block type magnets (block, common-coil)
 - Cos-theta/shell type magnets (traditional cos-theta, canted cos-theta)

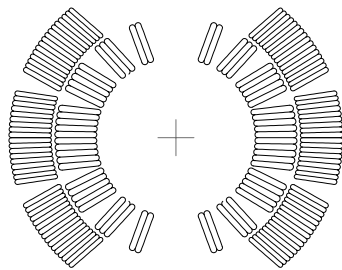

LHC

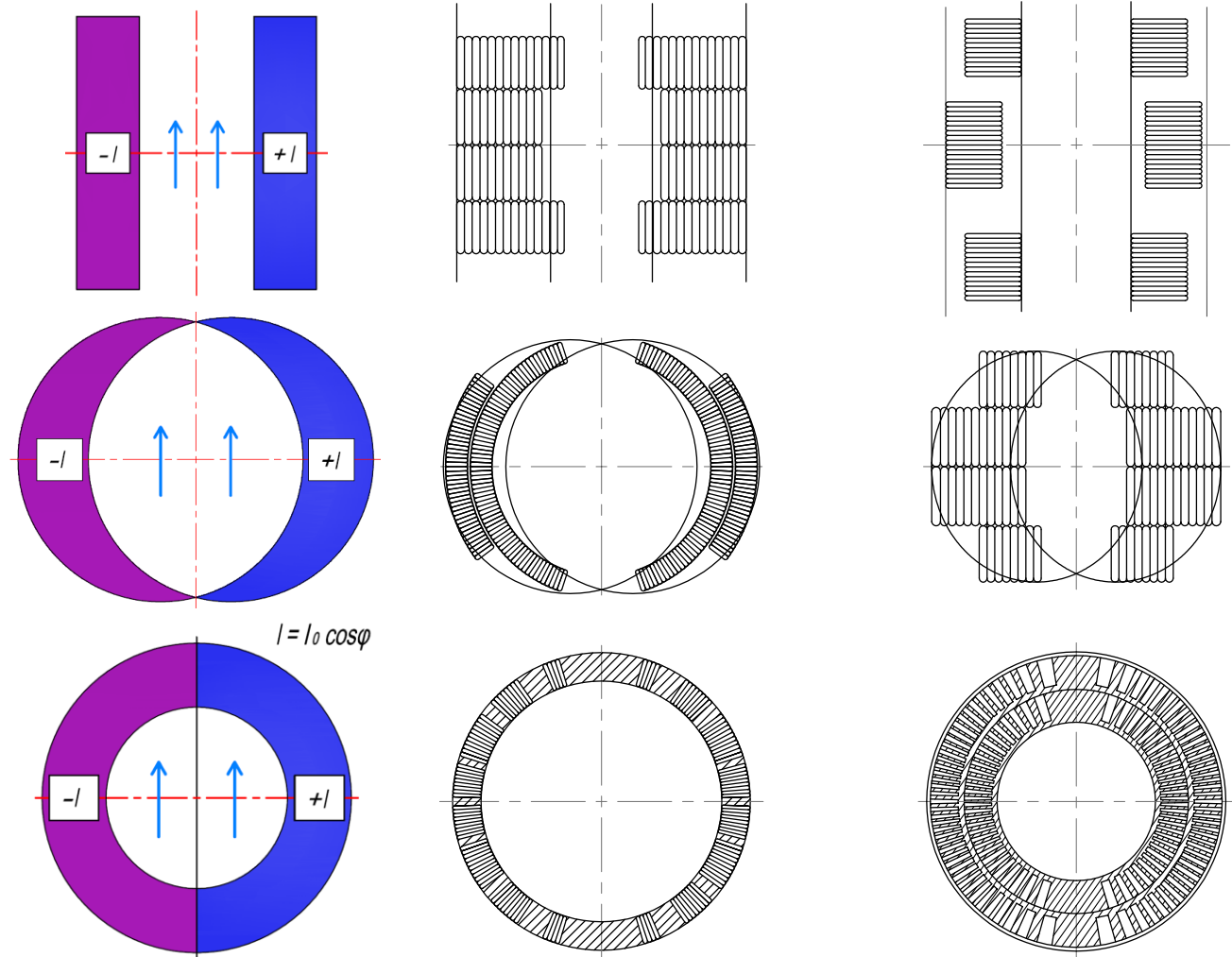

Magnetic design: Harmonics

The field can be expressed as (simple) series of coefficients
So, each coefficient corresponds to a “pure” multipolar field

$$B_y(x, y) + iB_x(x, y) = \sum_{n=1}^{\infty} C_n (x + iy)^{n-1} = \sum_{n=1}^{\infty} (B_n + iA_n)(x + iy)^{n-1}$$

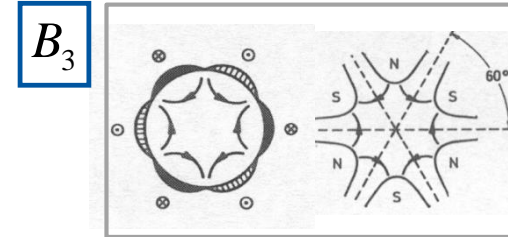
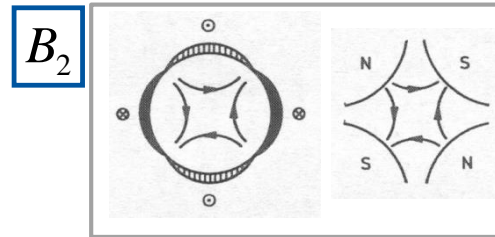
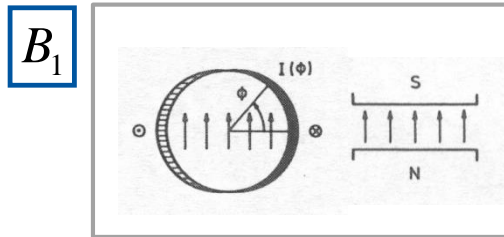

by K.-H. Mess, *et al.*

Magnetic design: Harmonics

The field can be expressed as (simple) series of coefficients
So, each coefficient corresponds to a “pure” multipolar field

Dipole

$$B_1 = \frac{2\mu_0}{\pi} J(R_{\text{out}} - R_{\text{in}}) \sin \varphi = \frac{2\mu_0}{\pi} Jw \sin \varphi$$

$$B_n = \frac{2\mu_0}{\pi} J \frac{(R_{\text{out}}^{2-n} - R_{\text{in}}^{2-n})}{n(2-n)} r_{\text{ref}}^{n-1} \sin(n\varphi), n = 3, 5, 7, \dots$$

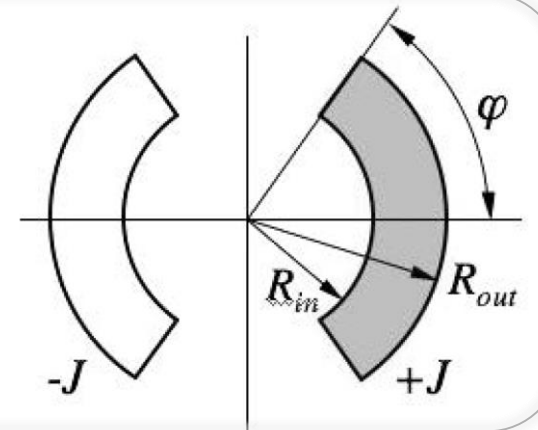

Magnetic design: Optimization of one layer designs

- We compute the central field given by a sector dipole with 2 blocks
- Equations to set to zero B_3 , B_5 and B_7

$$\begin{cases} \sin(3\alpha_3) - \sin(3\alpha_2) + \sin(3\alpha_1) = 0 \\ \sin(5\alpha_3) - \sin(5\alpha_2) + \sin(5\alpha_1) = 0 \end{cases}$$

- And with 3 blocks
- Equations to set to zero B_3 , B_5 , B_7 , B_9 and B_{11}

$$\begin{aligned} \sin(3\alpha_5) - \sin(3\alpha_4) + \sin(3\alpha_3) - \sin(3\alpha_2) + \sin(3\alpha_1) &= 0 \\ \sin(5\alpha_5) - \sin(5\alpha_4) + \sin(5\alpha_3) - \sin(5\alpha_2) + \sin(5\alpha_1) &= 0 \\ \sin(7\alpha_5) - \sin(7\alpha_4) + \sin(7\alpha_3) - \sin(7\alpha_2) + \sin(7\alpha_1) &= 0 \\ \sin(9\alpha_5) - \sin(9\alpha_4) + \sin(9\alpha_3) - \sin(9\alpha_2) + \sin(9\alpha_1) &= 0 \\ \sin(11\alpha_5) - \sin(11\alpha_4) + \sin(11\alpha_3) - \sin(11\alpha_2) + \sin(11\alpha_1) &= 0 \end{aligned}$$

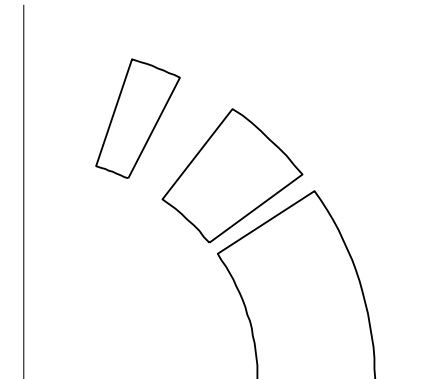
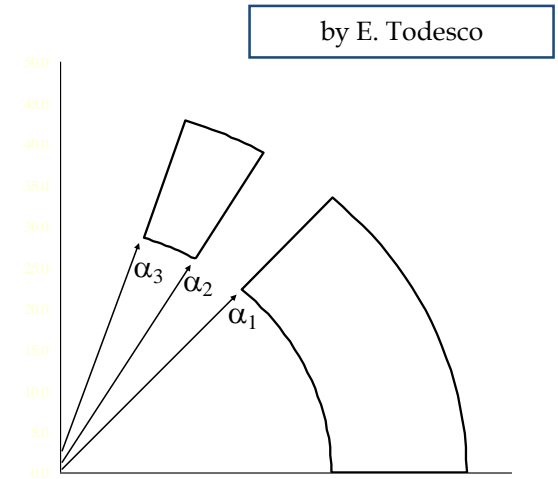

Two wedges, $b_3=b_5=b_7=b_9=b_{11}=0$
 $[0^\circ-33.3^\circ, 37.1^\circ-53.1^\circ, 63.4^\circ-71.8^\circ]$

A review of coil layouts: Existing

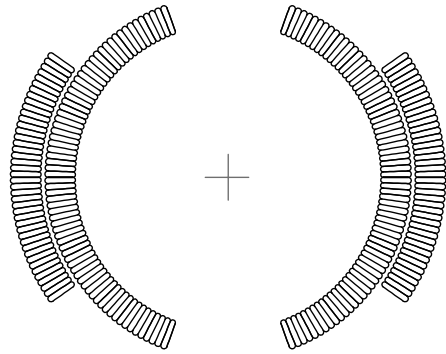

TEVATRON
USA, 1983-2011

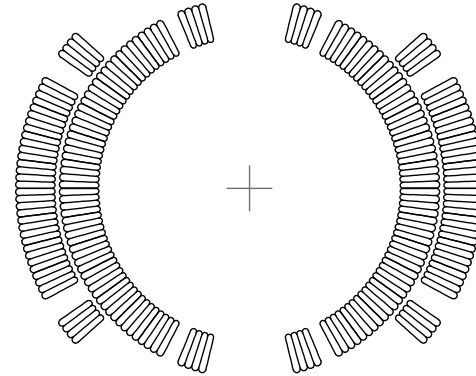

HERA
Germany, 1991-2007

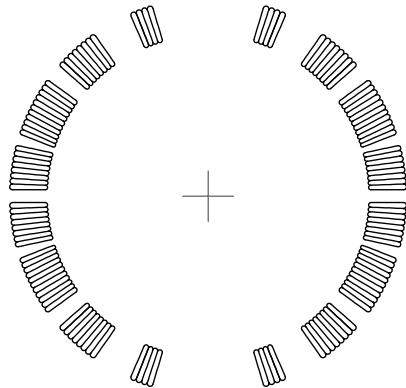

RHIC
USA, since 2000

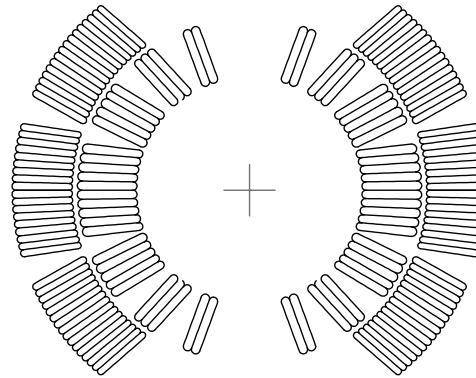

LHC
CERN, since 2008

The Winding House at CERN (bld. 180)



Reaction furnace(s)

Dedicated ovens with controlled atmosphere

Ramp at 25°C/h, held during 72 h at 210°C

Ramp at 50°C/h, held during 48 h at 400°C

Ramp at 50°C/h, held during 50 h at 650°C



Impregnation tank

Dedicated autoclave for vacuum impregnation with epoxy

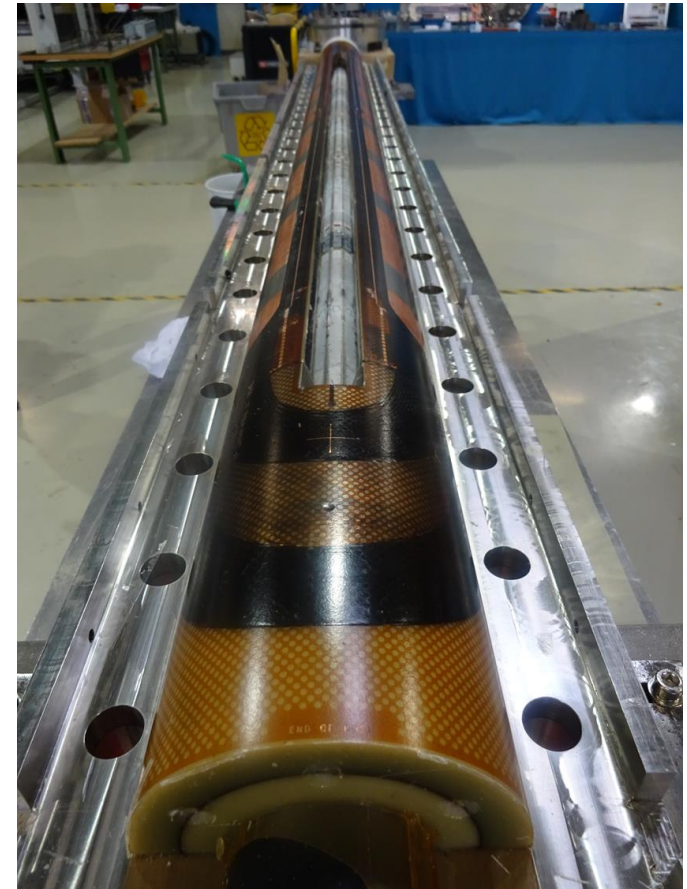
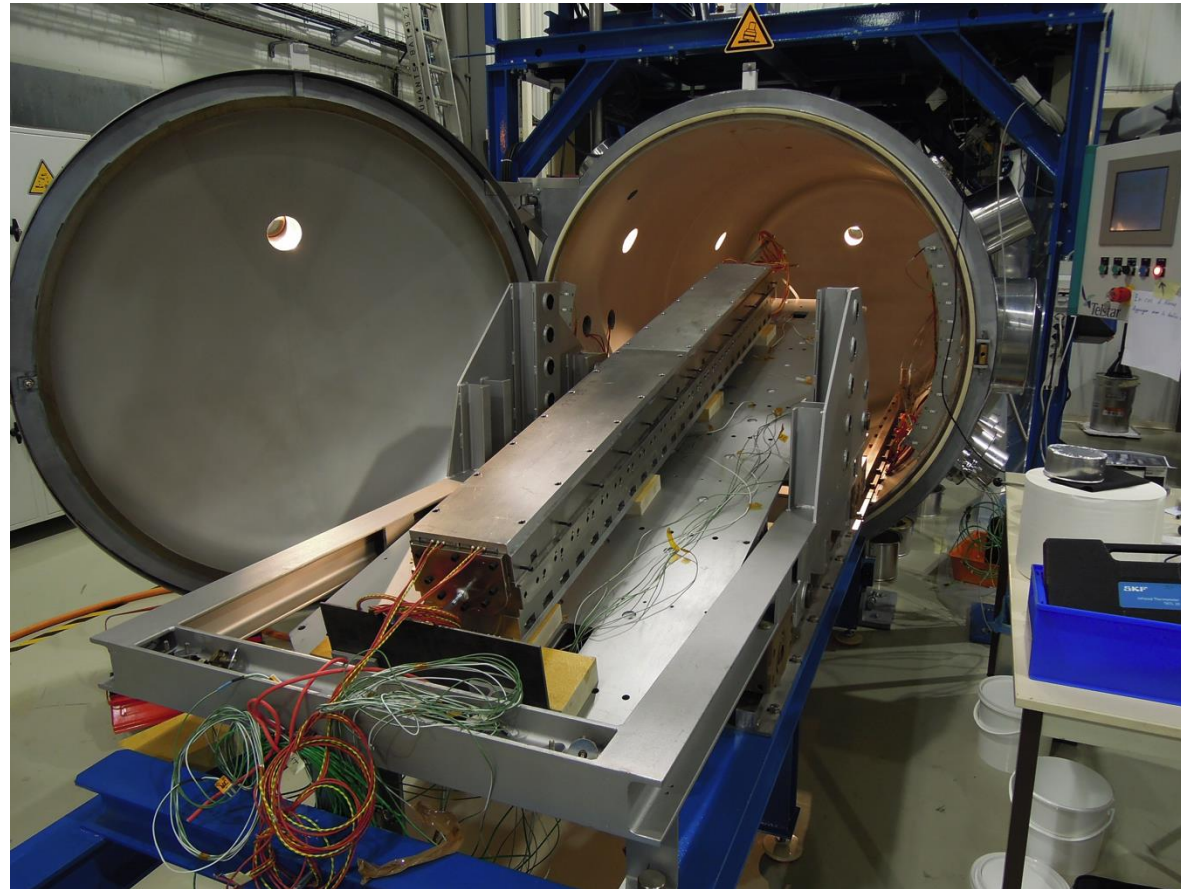

How much superconductor is in the cable?

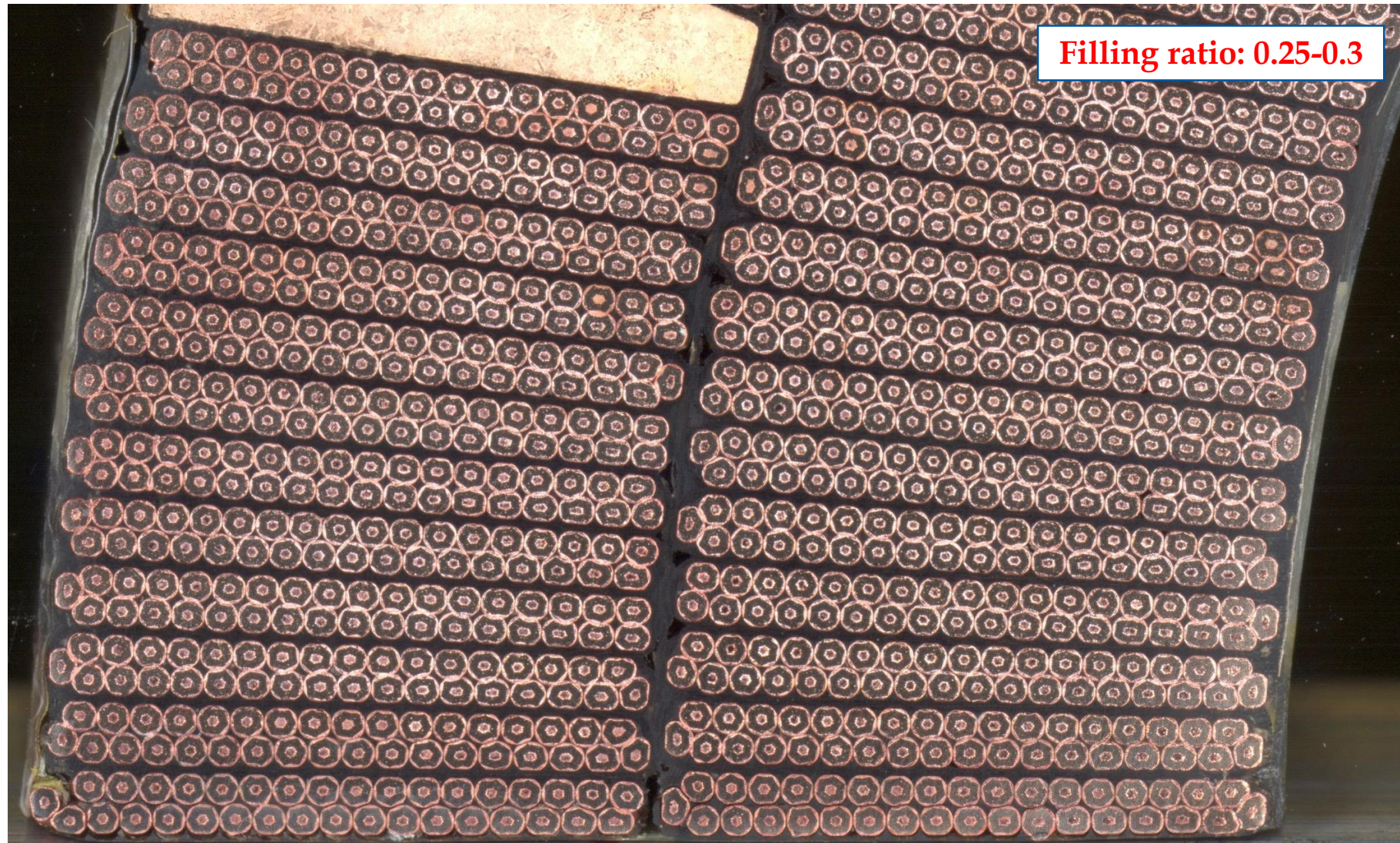

How to select the J in the coil?

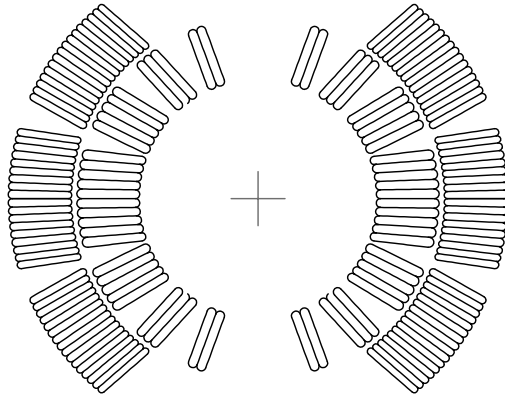

LHC

- LHC main dipole at nominal operation:
 $B_{op} = 8.33$ T, $I_{op} = 11\ 850$ A, $J_{eng} = \sim 450$ A/mm²

IBI (T)

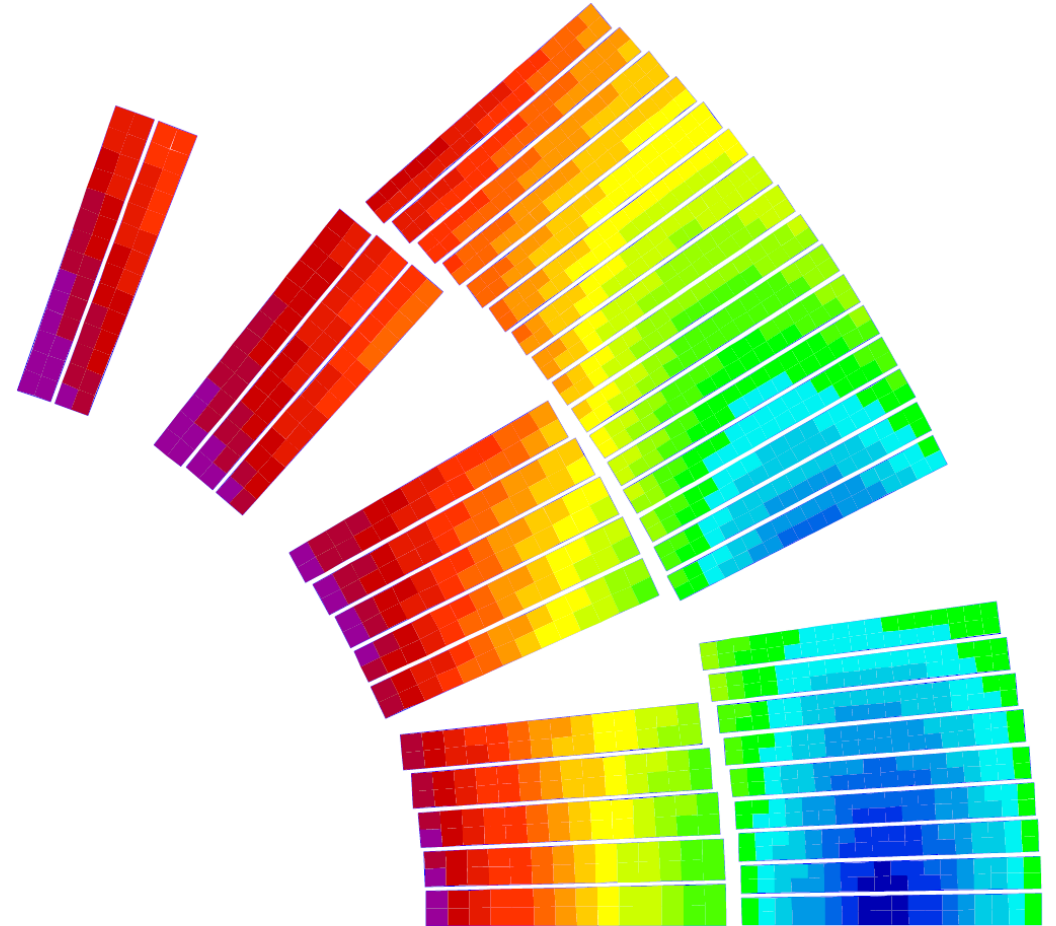
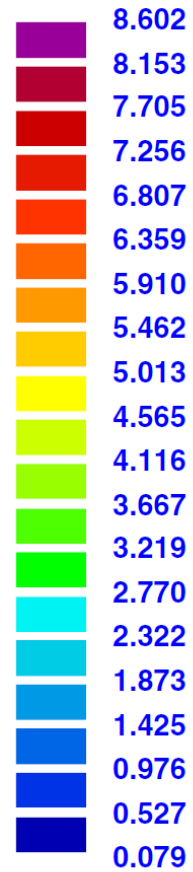

How to select the J in the coil?

Why margins?

- Reach design field
- Limit number of training quenches
- Avoid quenches during operation

Margins:

- Load line margin
- Temperature margin
- Current margin

How to select the margins? Typically, designs are done for load line margin (LHC & FCC: 14%)

How is it selected? Empirically: long discussions and many prototypes!

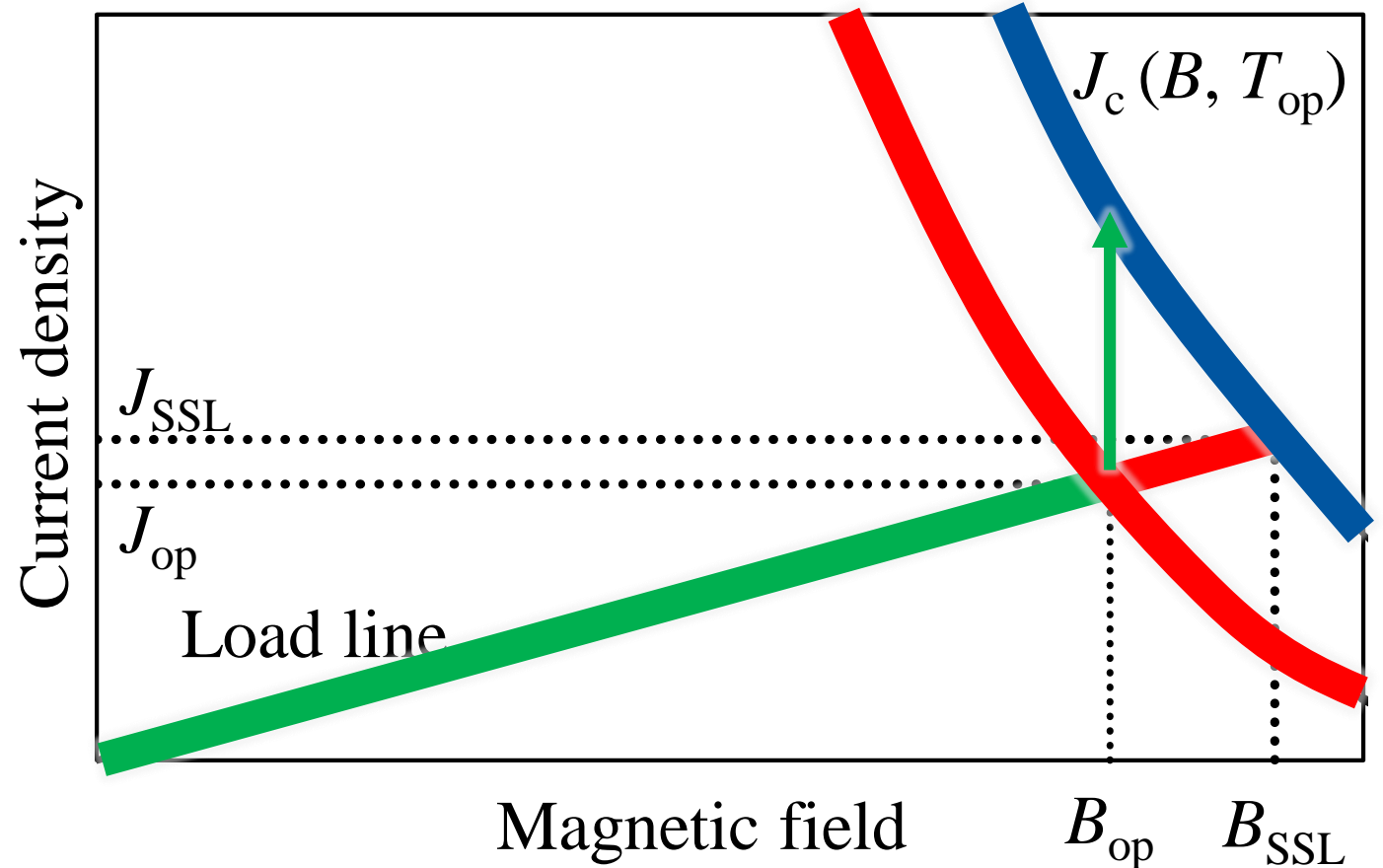

Margin on the load line

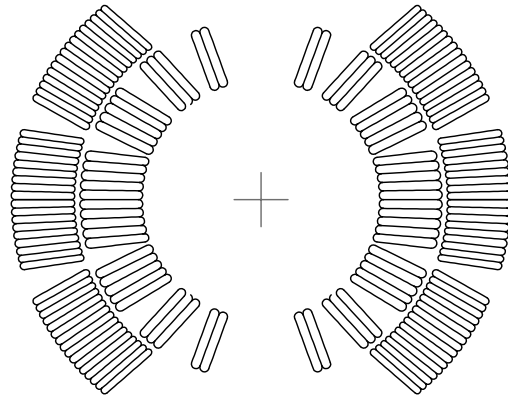

LHC

Margin to quench (%)

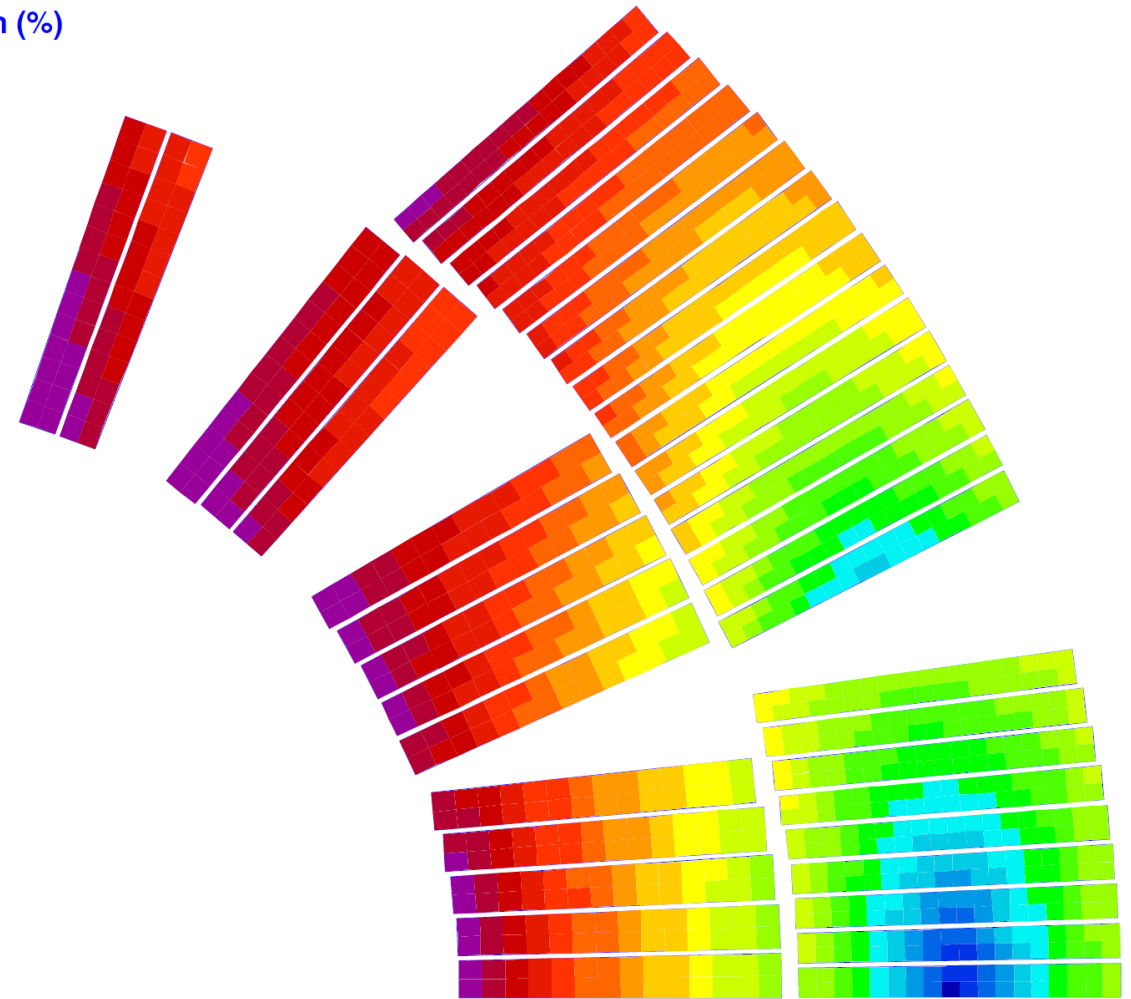
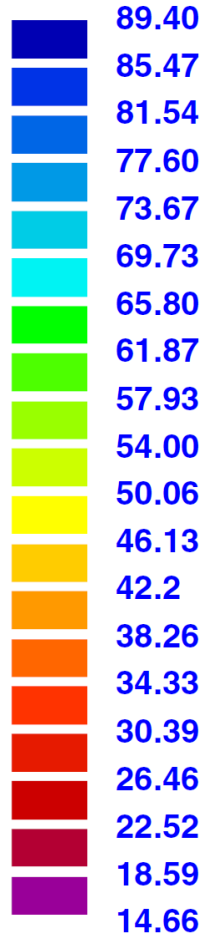

Temperature margin

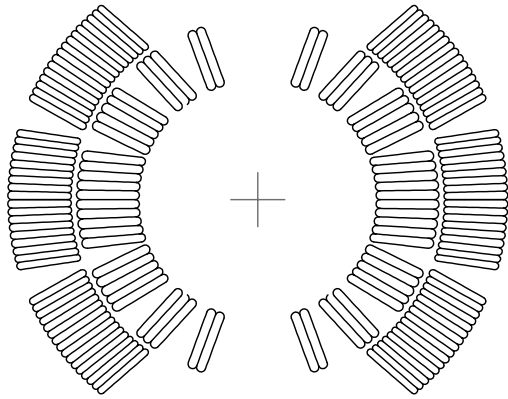

LHC

Temperature margin (K)

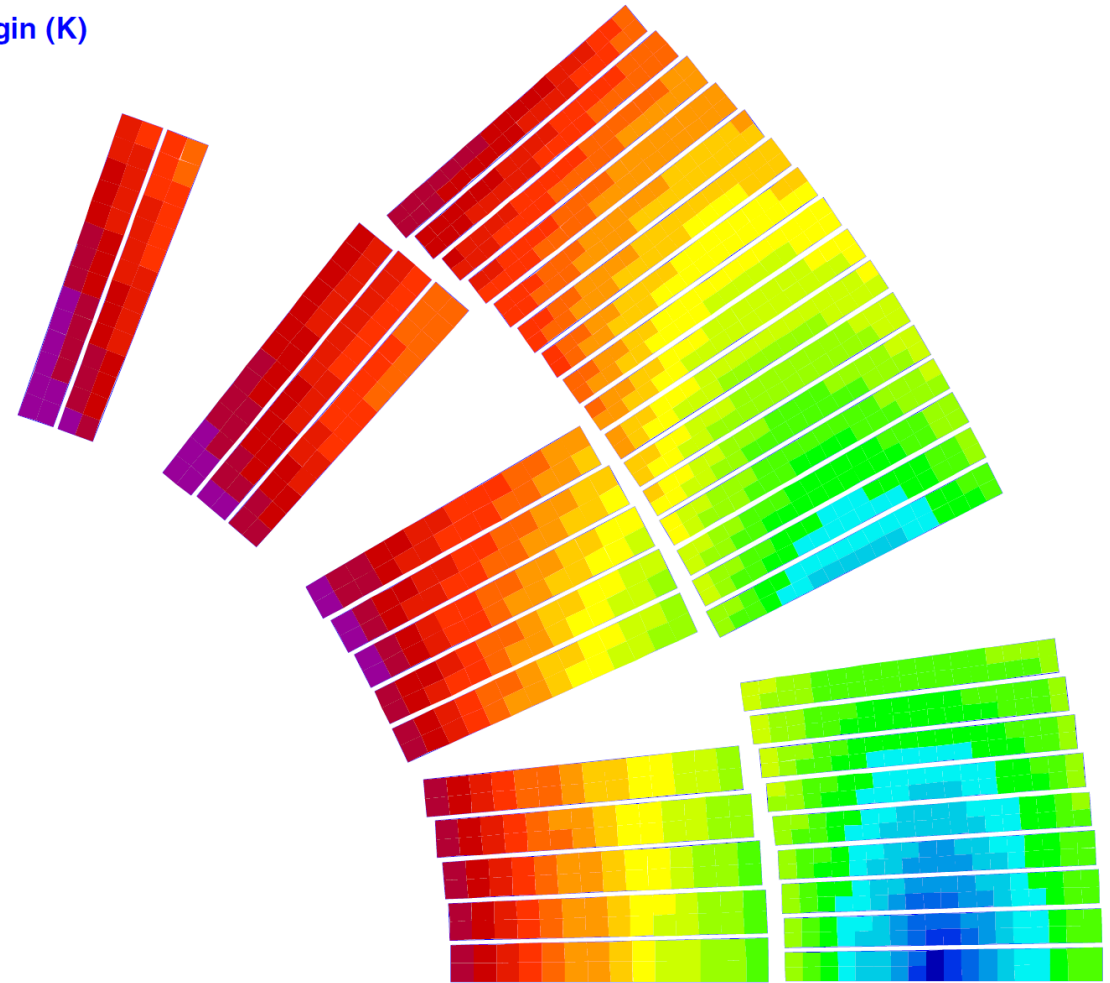
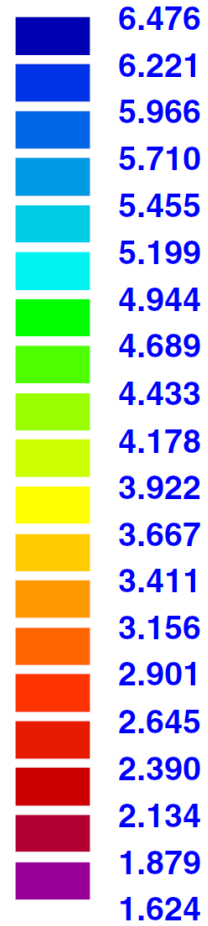

Circuit protection

- LHC MBs are powered in 8 sectors, each with 154 MBs
- The stored energy is 1.1 GJ:
→Corresponds to the kinetic energy of a fully loaded jumbo jet at start

$$E_m = \int_0^v \frac{B^2}{2m_0} dv = \frac{1}{2} LI^2$$

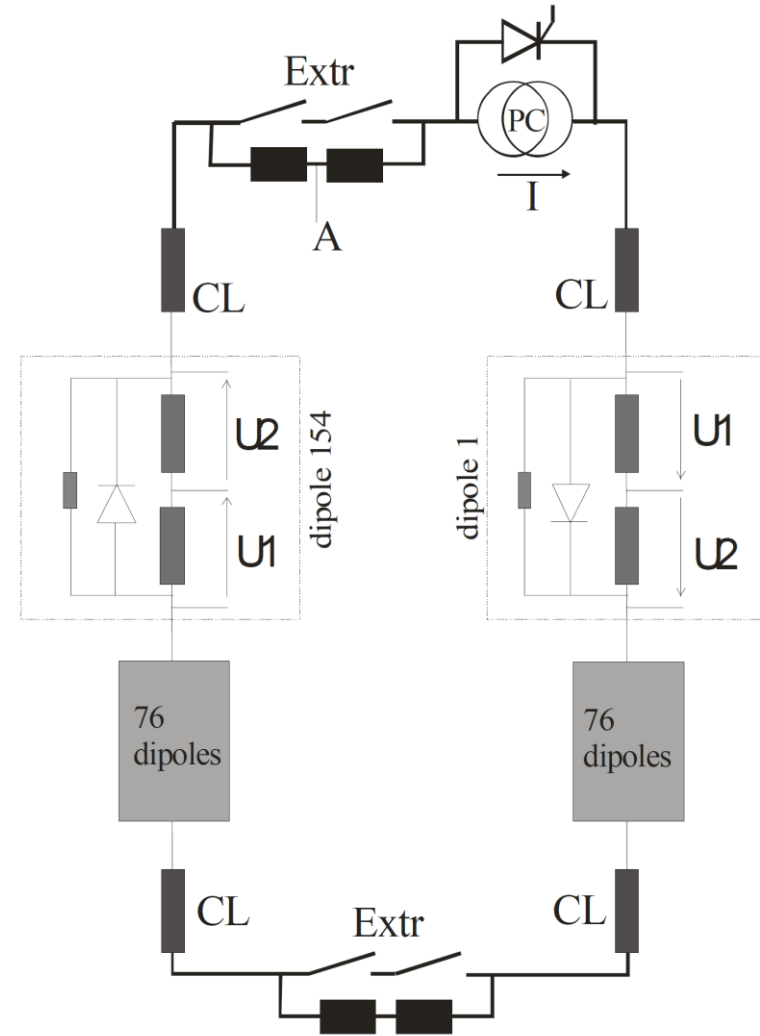

Magnet quench protection

- In case a quench occurs, the stored energy does not allow to be extracted within the required time (few tens of ms): too large voltages (several kV-MV, depending on the circuit) would be required

$$U = L di/dt \text{ (LHC MB: } L = 98.7 \text{ mH/magnet, } I = 11.85 \text{ kA)}$$

→ A discharge in 0.1 s would yields a voltage of ~12 kV

- Alternative:** stored energy is damped into the entire magnet by quenching it: upper theoretical limit can be calculated with adiabatic model

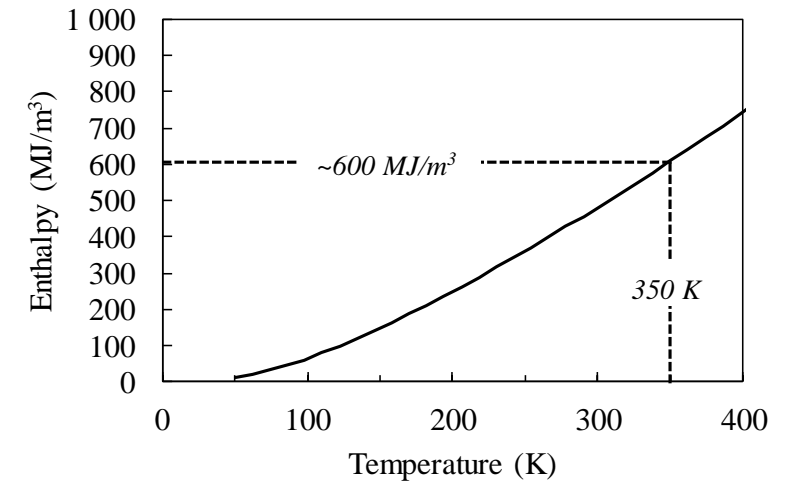
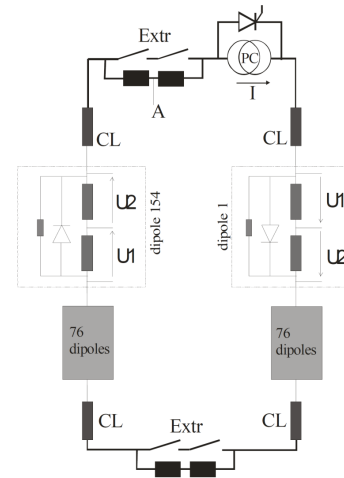
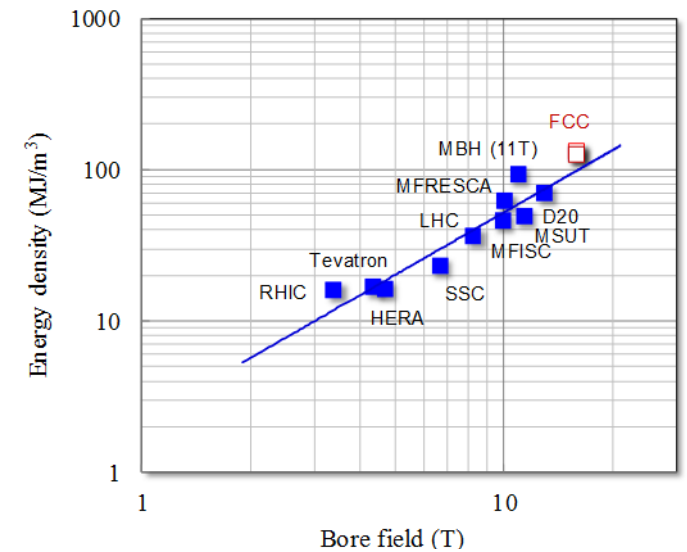

Quench heater

- In case a quench is detected, the magnet will be quenched (brought to normal conducting) within ~ 40 ms everywhere
- The final peak temperature for a given magnet depends on the time span to quench the magnet and the stored energy density

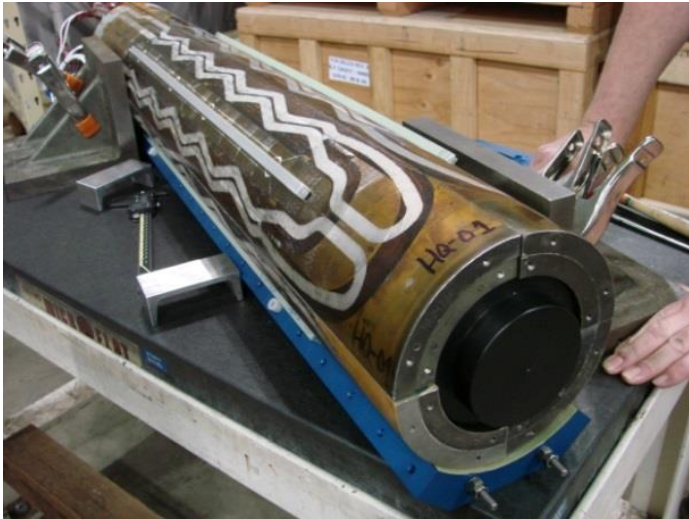

What is around the coils?

- How do we keep the coils in place despite the large forces?
- How do we keep them cool?
- How we ensure that they perform well in the tunnel: testing!

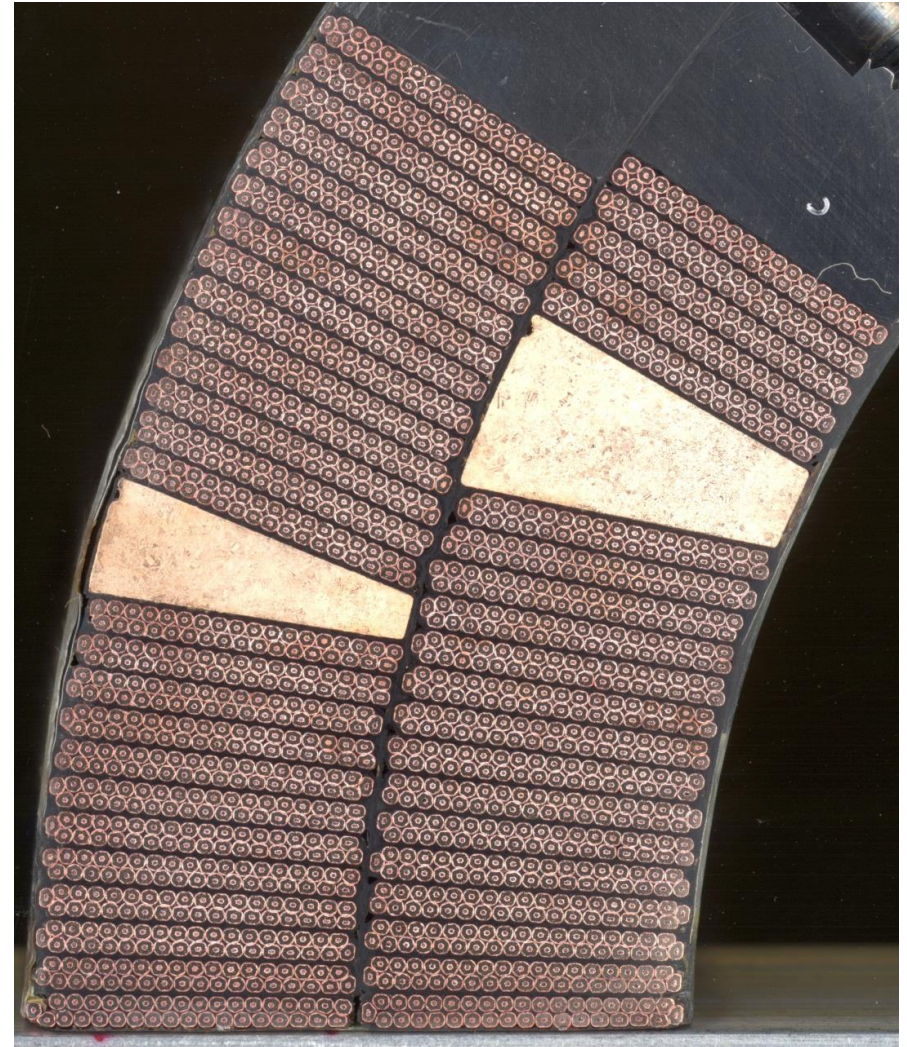

Mechanical structure

The e.m. forces in a dipole/quadrupole magnet tend to push the coil

- Towards the mid plane in the vertical-azimuthal direction ($F_y, F_\theta < 0$)
- Outwards in the radial-horizontal direction ($F_x, F_r > 0$)

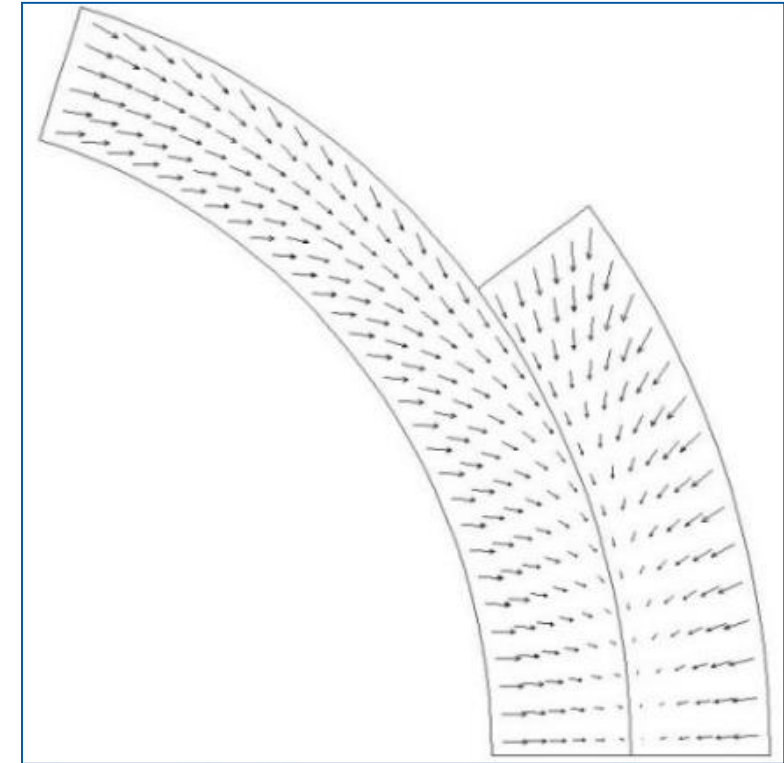
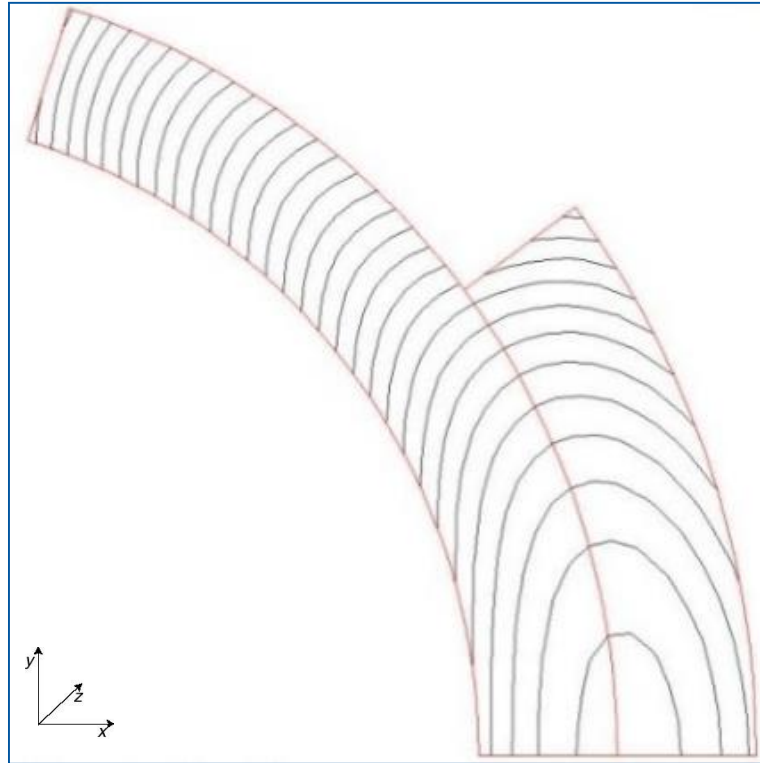
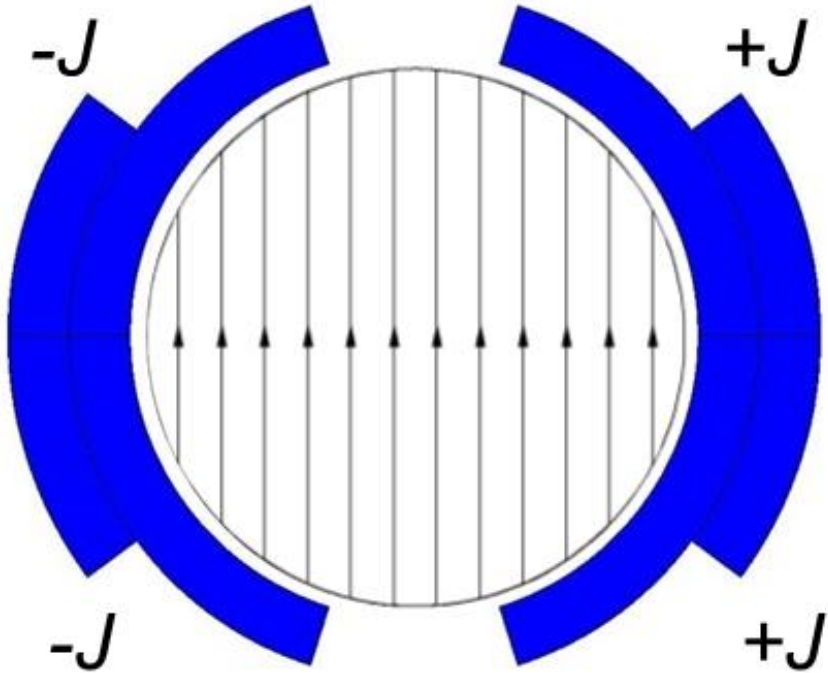

Mechanical structure: Examples

Nb-Ti LHC MB

Values for a central field of 8.33 T

- $F_x = 340$ t per meter: ~300 compact cars/m
- Precision of coil positioning: 20-50 μm
- $F_z = 27$ t: ~weight of the cold mass

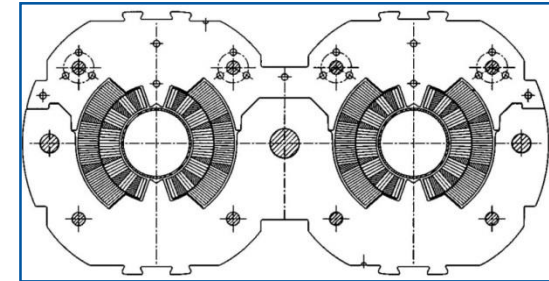
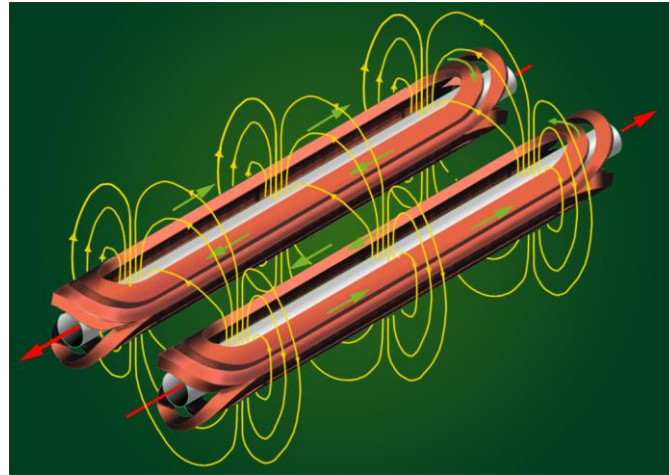

Nb₃Sn dipole (Fresca-2)

Values for a central field of 13 T

- $F_x = 770$ t per meter and quadrant
- $F_z = 72$ t/octant

These forces are applied to an objet with a cross-section of 150x100 mm and by the way, it is brittle

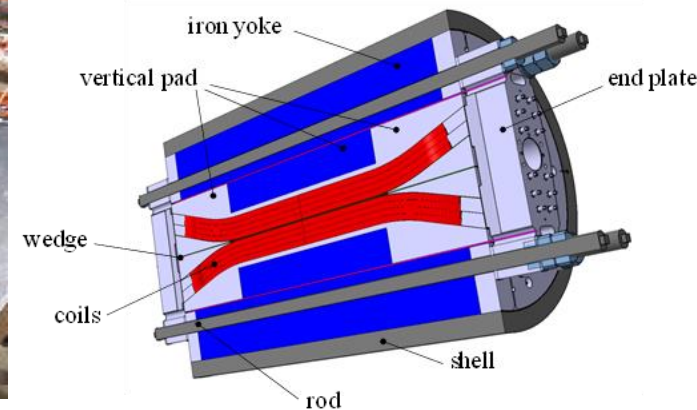

How to do to avoid movement and tensile stress?



How to do to avoid movement and tensile stress?

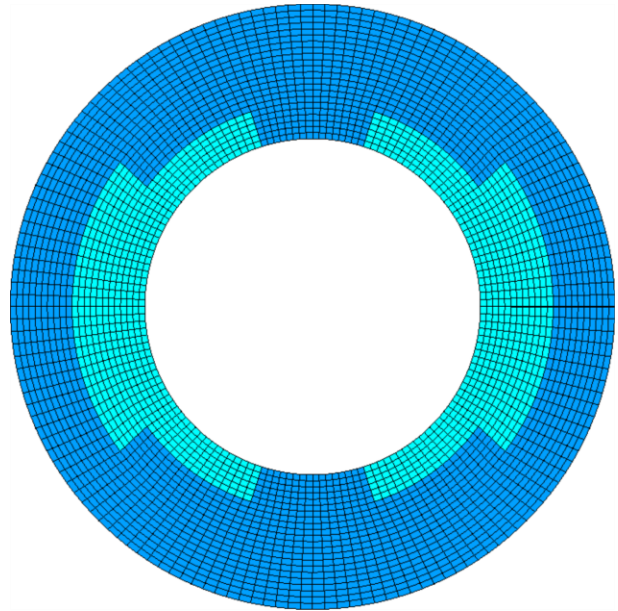

No pre-stress
No e.m. force

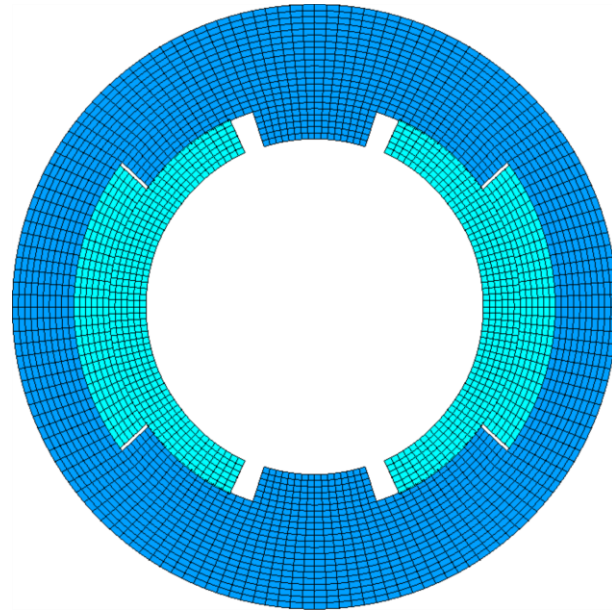

No pre-stress
With e.m. force

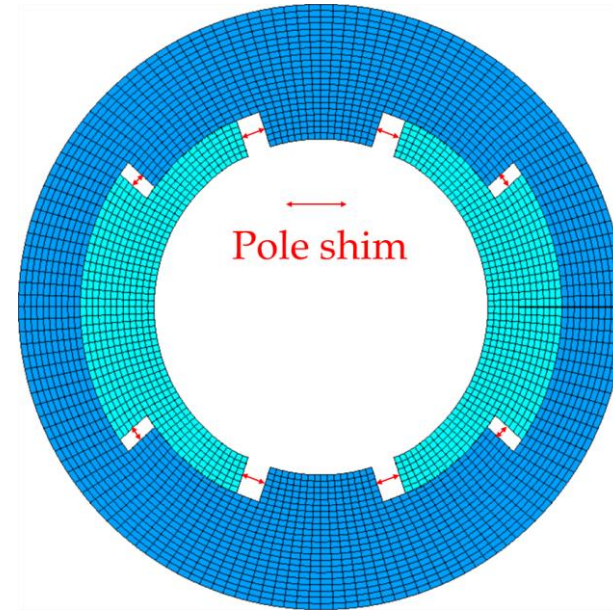

Pre-stress
No e.m. force

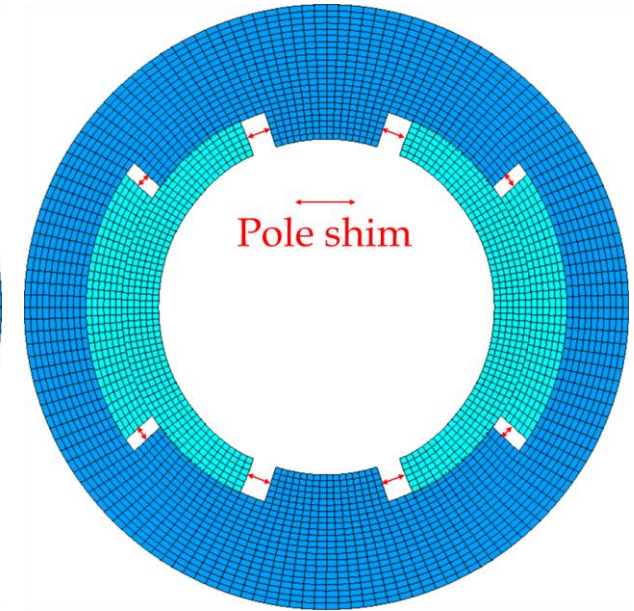

Pre-stress
with e.m. force

Mechanics of superconducting magnets: Collars

- Implemented for the first time in Tevatron, since then, almost always used
- Composed by stainless-steel or aluminium laminations few mm thick.
- By clamping the coils, the collars provide
 - coil pre-stressing;
 - rigid support against e.m. forces
 - precise cavity

Tevatron

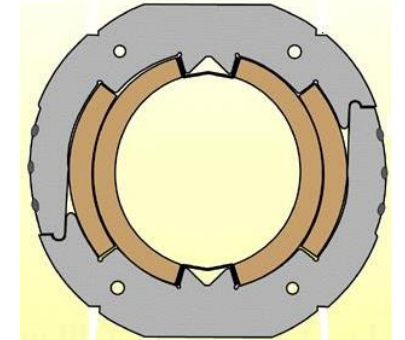
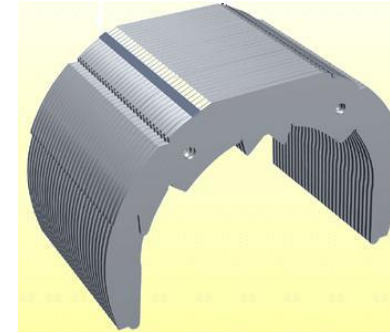

SSC

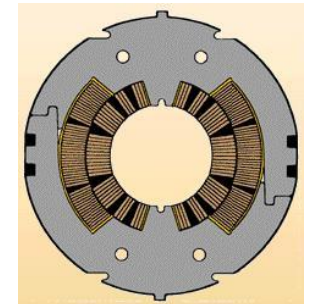
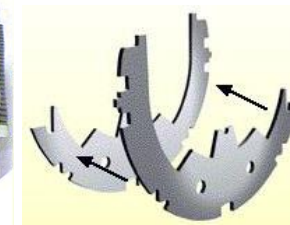
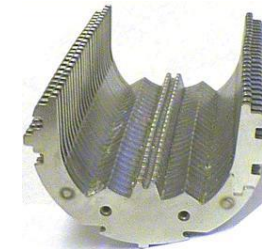

LHC

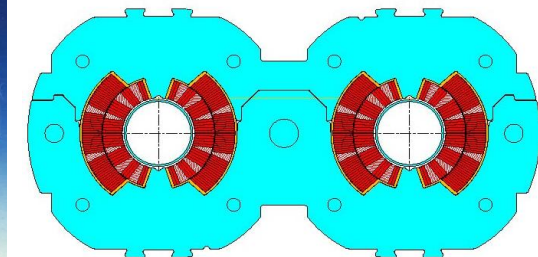
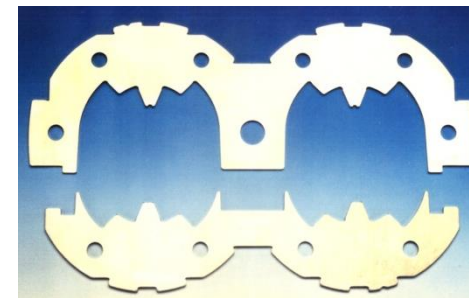

Mechanics of superconducting magnets: Collars

Collaring of a dipole magnet



Collaring of a quadrupole magnet

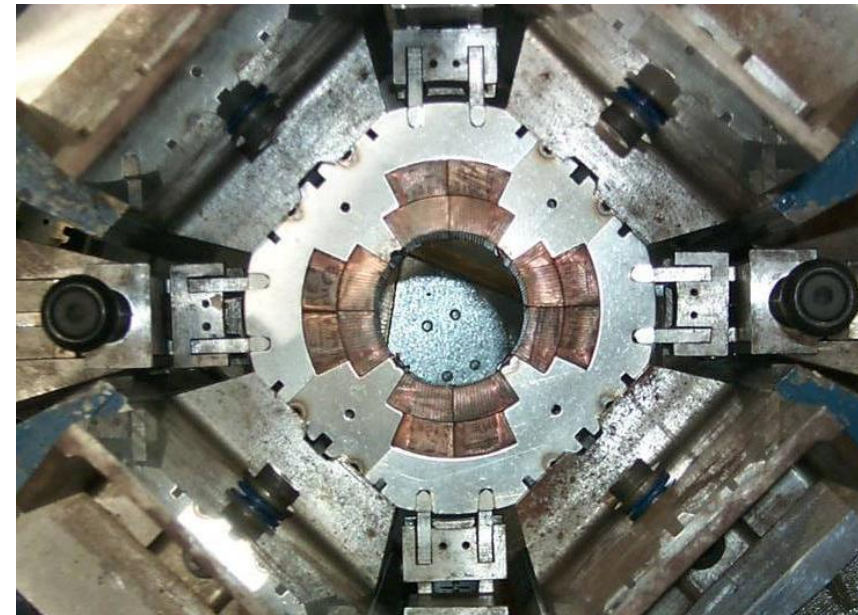

Mechanics of superconducting magnets: Iron yoke

- Iron yoke are also made in laminations (several mm thick)

Magnetic function:

- contains and enhances the magnetic field.

Structural function

- tight contact with the collar
- it contributes to increase the rigidity of the coil support structure and limit radial displacement.

Holes are included in the yoke design for

- Correction of saturation effect
- Cooling channel
- Assembly features
- Electrical bus

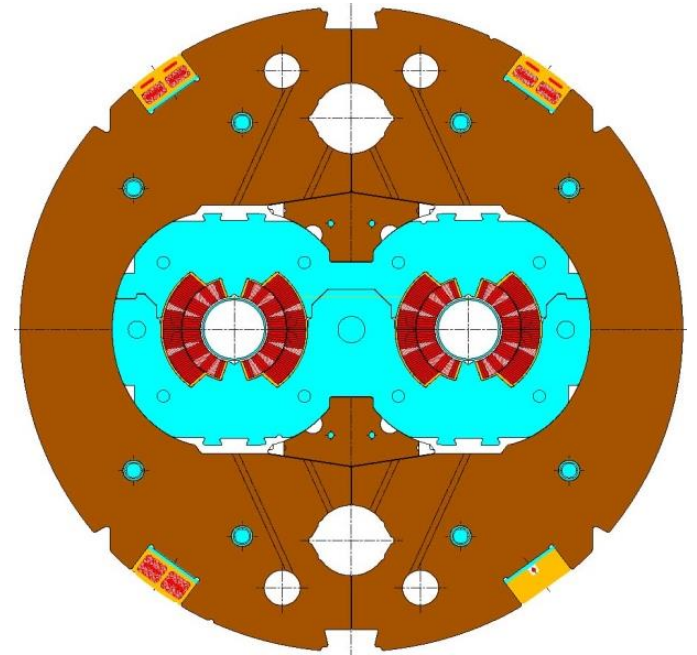

Mechanics of superconducting magnets: Shell structure

Alternative structure, principle is based on different contraction coefficients:

- No large scale infrastructure required
- Only part of pre-stress is applied at ambient temperature

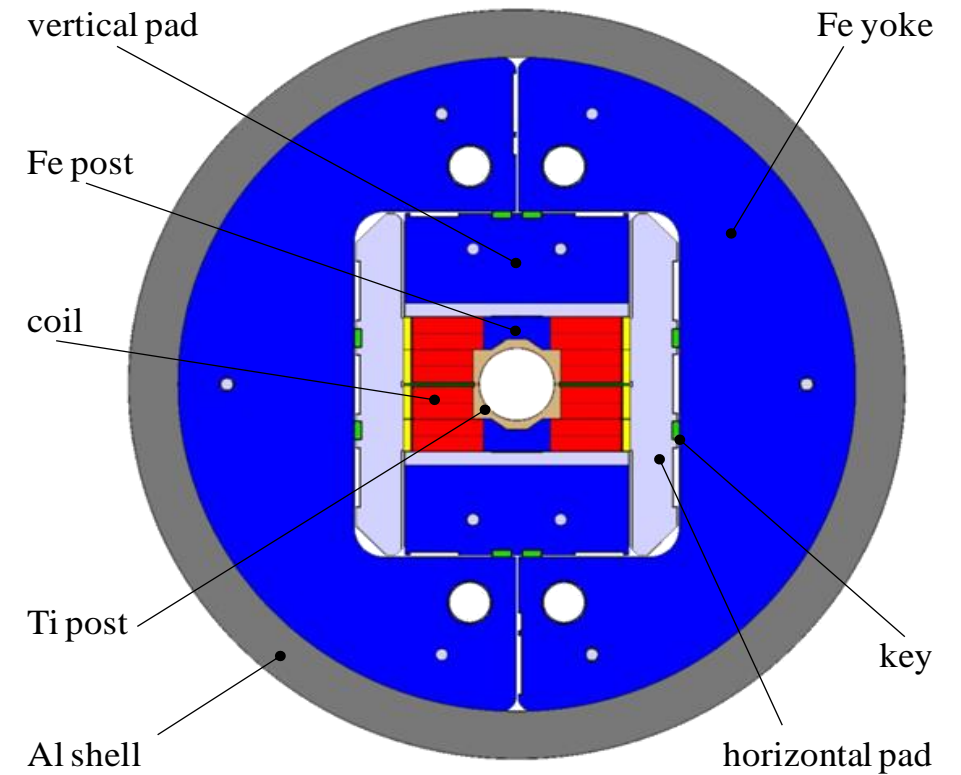

Material	α in mm/m
	293 K \rightarrow 4.2 K
Coil	3.88
Austenitic steel 316LN	2.8
Al 7075	4.2
Ferromagnetic iron	2.0
Pole (Ti6Al4V)	1.7

Cold mass

- The shell constitutes a containment structure for the liquid Helium.
- It is composed by two half shells of stainless steel welded around the yoke with high tension (about 150 MPa for the LHC dipole).
- With the iron yoke, it contributes to create a rigid boundary to the collared coil.
- If necessary, during the welding process, the welding press can impose the desired curvature on the cold mass
- In the LHC dipole the nominal sagitta is of 9.14 mm over ~14.3 m

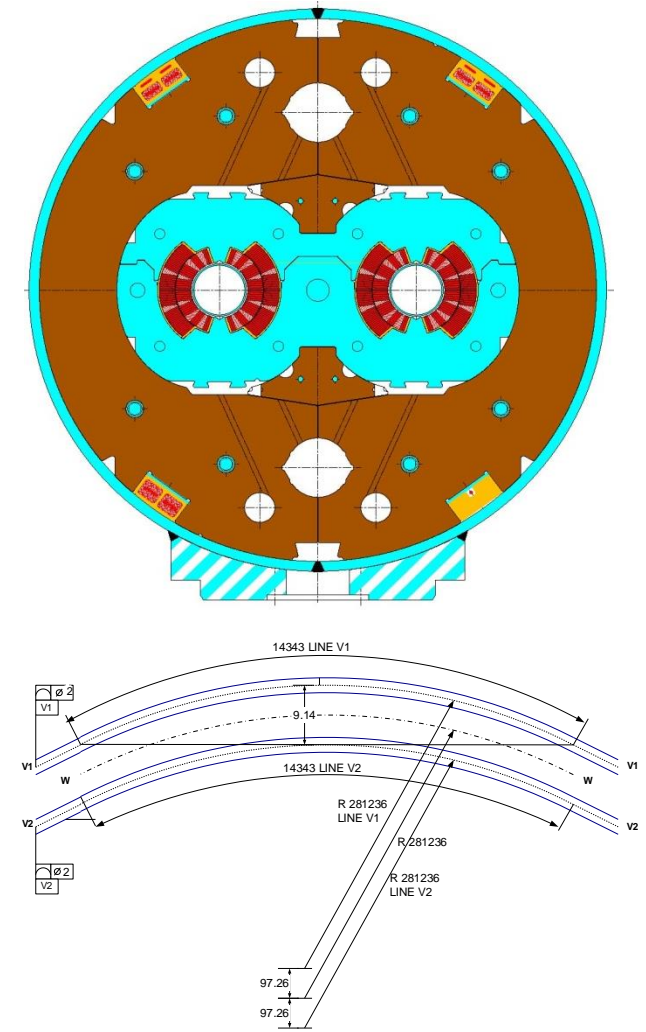

Cold mass

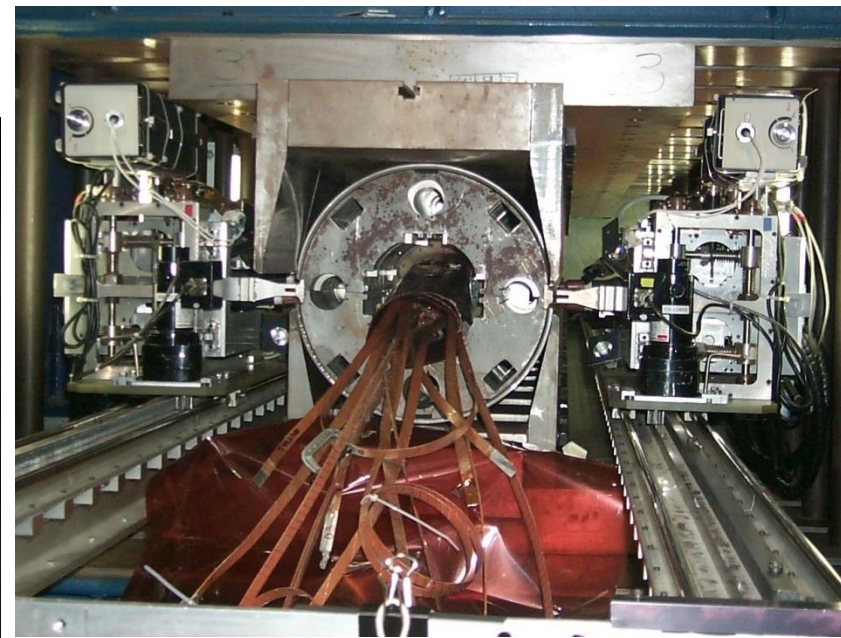
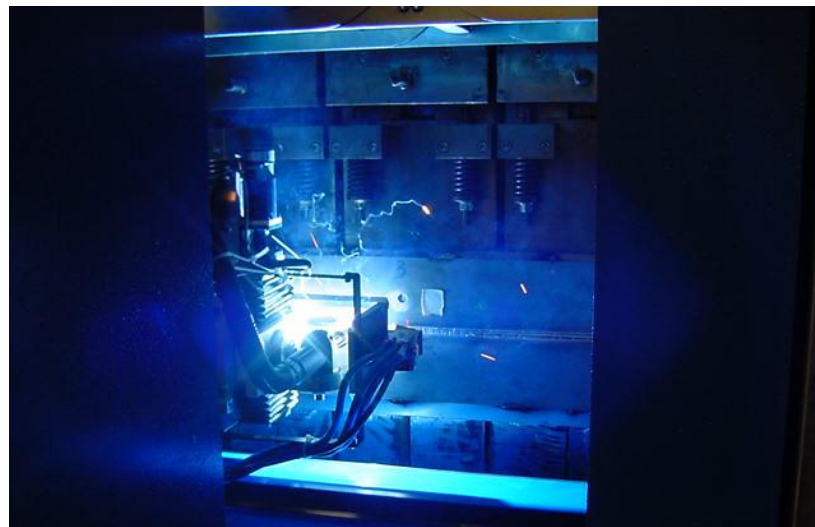
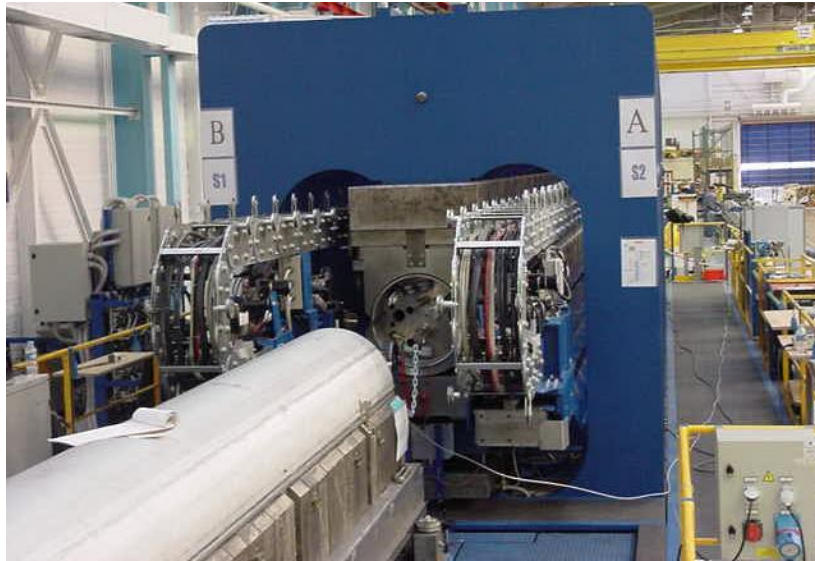

An overview of the infrastructure (bldg. 180)...



**Finishing benches
Geometrical measurements**



15m Welding press



15m Collaring press



Pressure/leak bench



**Nb₃Sn
Reaction
furnace**



**Yoke assembly
bench**



Welding press for 2m models



**Half Yoke
returning
bench**

**Cold mass
assembly
bench**

**Collared coil
returning
bench**

**Collared coil magnetic
measurement bench**

**Cold mass magnetic
measurement bench**

**Impregnation
chamber**

"Winding house"

Cryo-magnets!

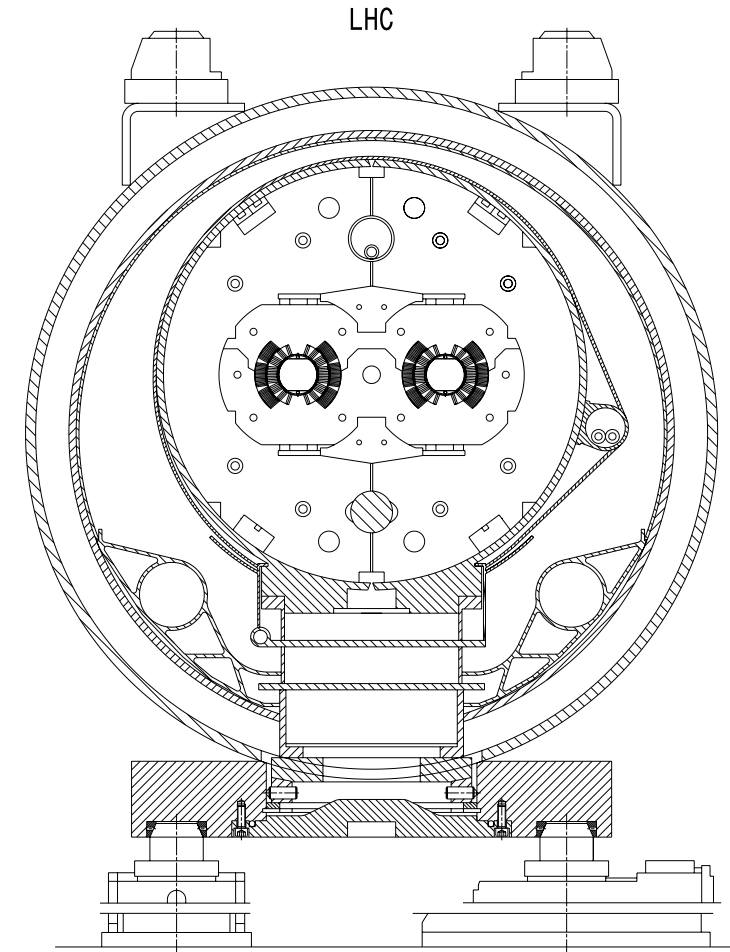
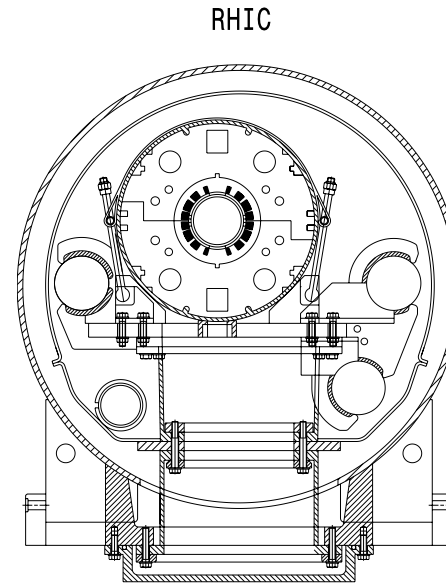
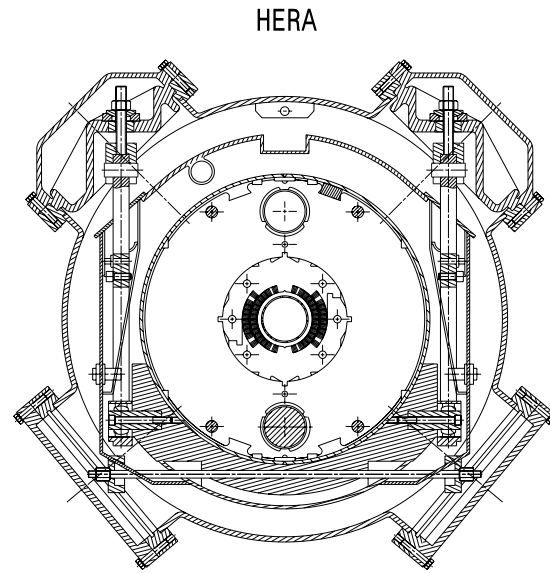
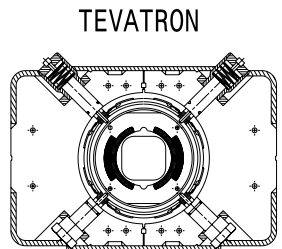

	Tevatron	HERA	RHIC	LHC
Operation period	1983-2011	1991-2007	since 2000	since 2008
Aperture (mm)	76	75	80	56
Magnetic length (m)	6.1	8.8	9.45	14.3
Nominal bore field (T)	4.3	5.3	3.5	8.3
Nominal current (kA)	4.3	5.7	5.1	11.9
Stored energy at I_{nom} (MJ)	0.30	0.94	0.35	6.93
Operation temperature (K)	4.6	4.5	4.3-4.6	1.9

Testing

All magnets to be installed in a machine have to go through testing.

A detailed test plan is elaborated. Main points:

- Electrical integrity (test voltage 1-2 kV)
- Performance (field, field quality): Reduce training!
- Memory after thermal cycle: Keep memory!

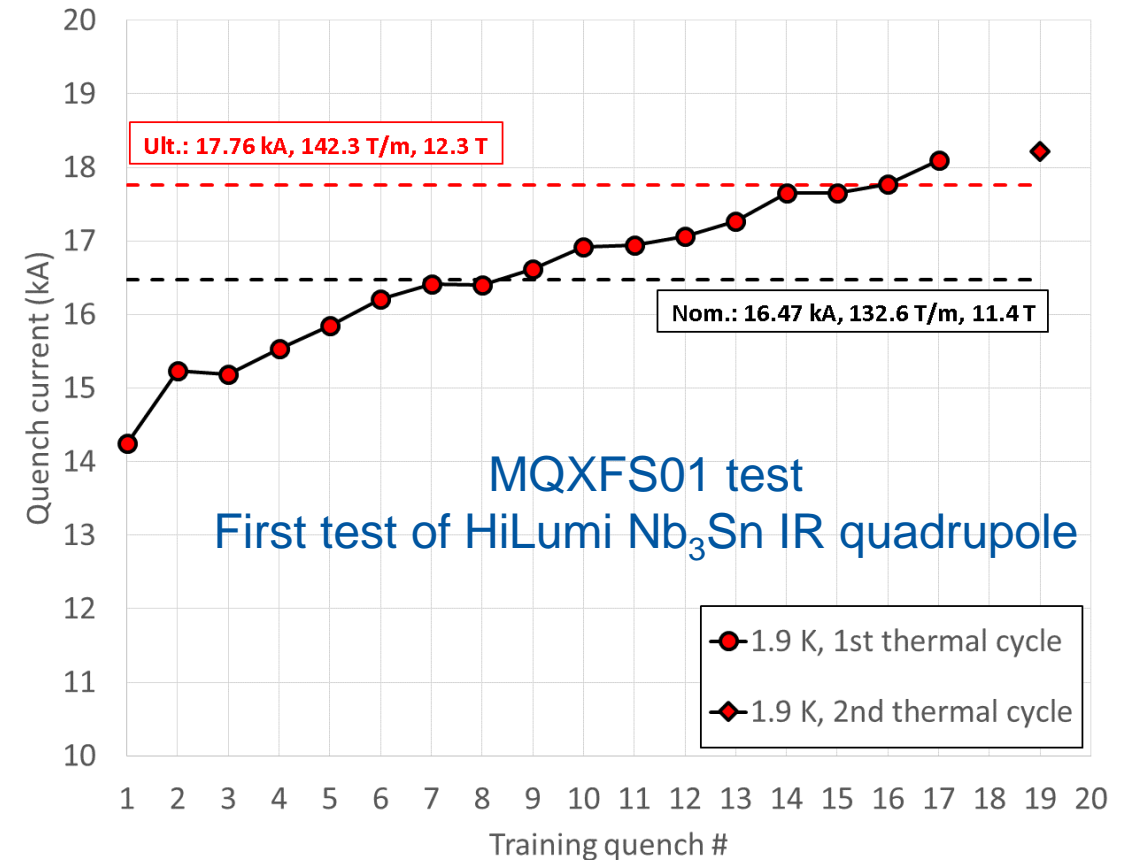

Training

Main causes

- Frictional motion
 - E.m. forces → motion → quench
 - Coil locked by friction in a secure state
- Epoxy failure
 - E.m. forces → epoxy cracking → quench
 - Once epoxy locally fractured, further cracking appears only when the e.m. stress is increased.
- Magnets operate with margin: Nominal current reached with few quenches.

In general, very emotional process!

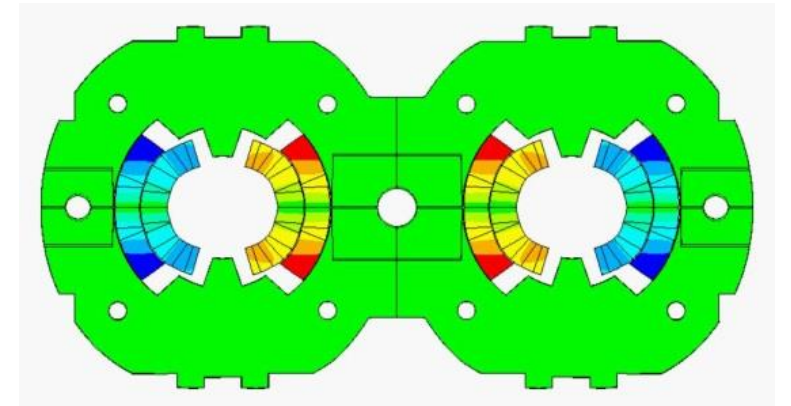
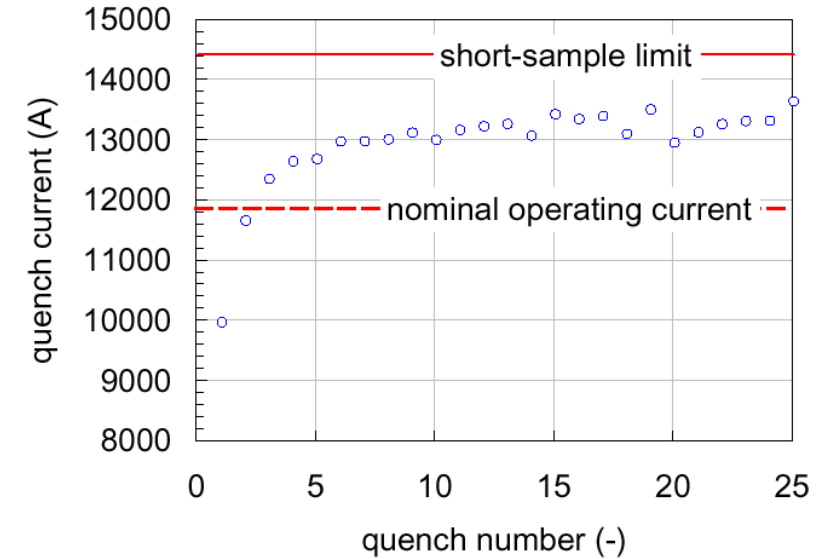

Memory

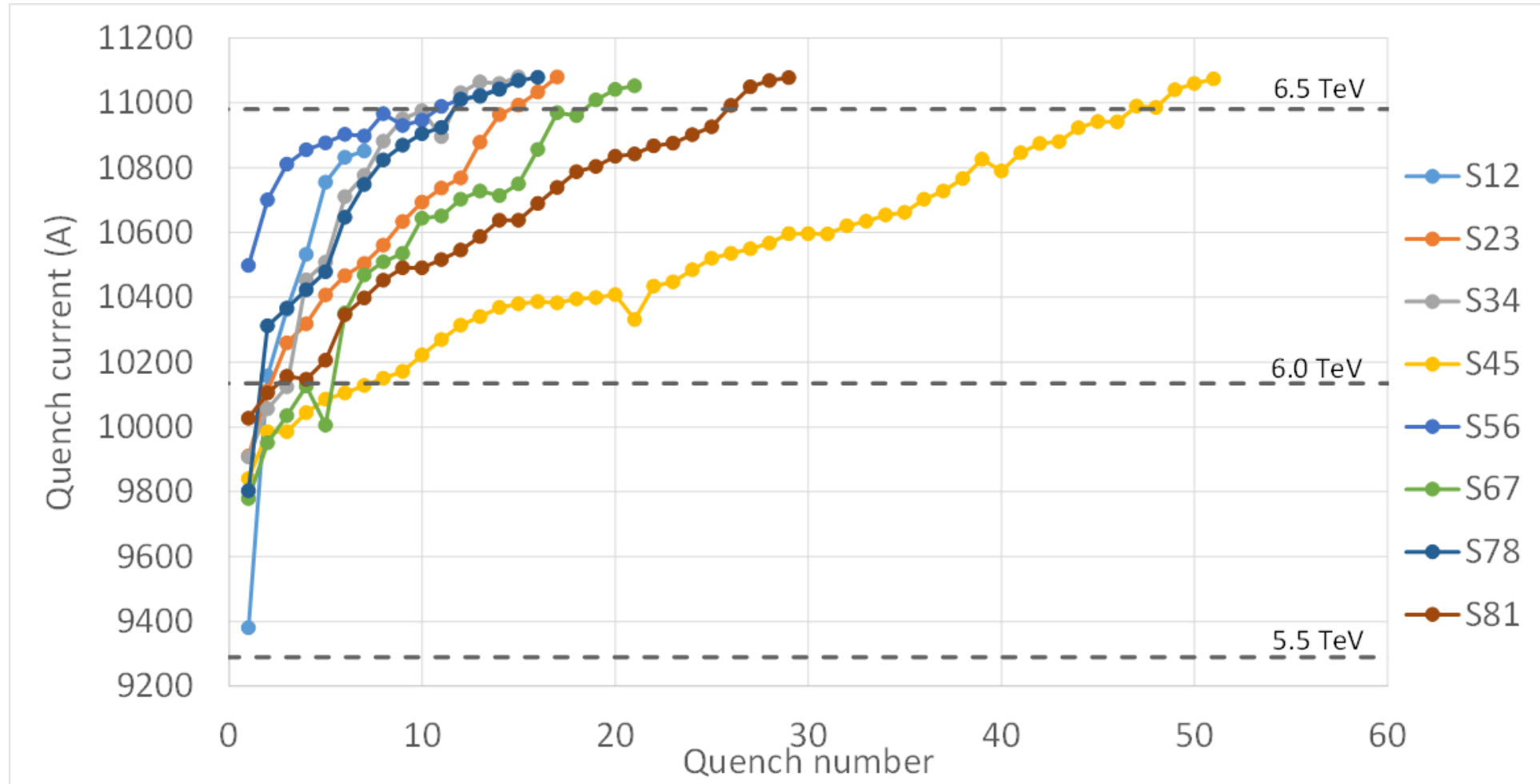

The LHC dipole magnet

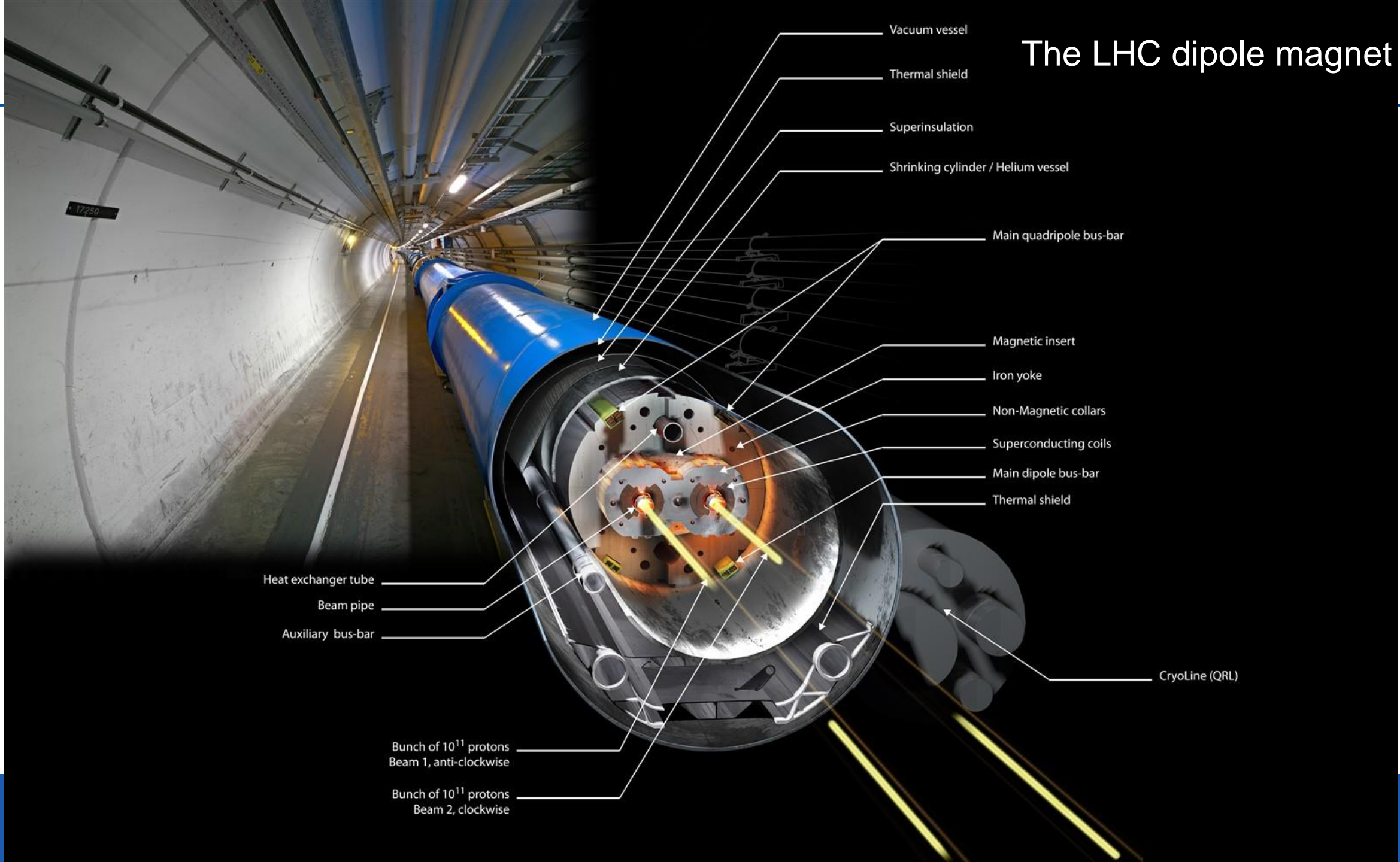

LHC, what next? HL-LHC!

- Achieve instantaneous luminosities a factor of five larger than the LHC nominal value
- Enable the experiments to enlarge their data sample by one order of magnitude compared with the LHC baseline programme

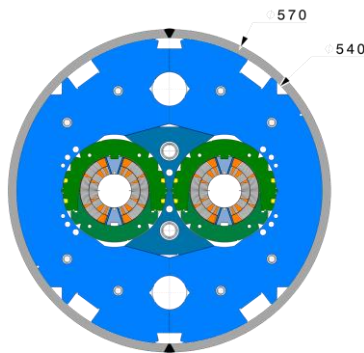
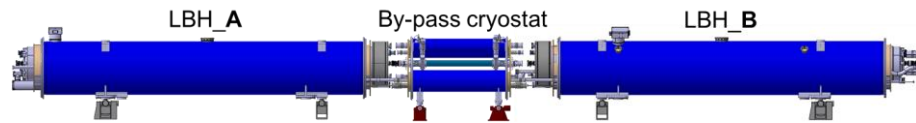

11 T dipole

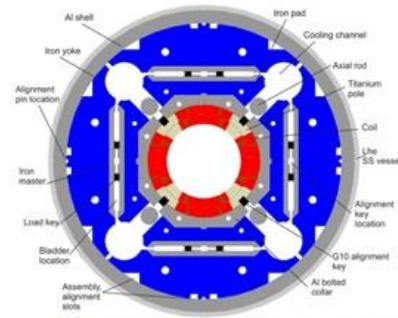

Triplet [G. Ambrosio, P. Ferracin et al.]

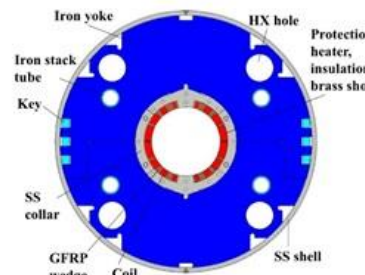

D1 [T. Nakamoto, et al.]

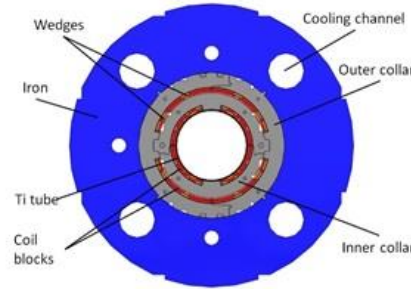

MCBXF [F. Toral, et al.]

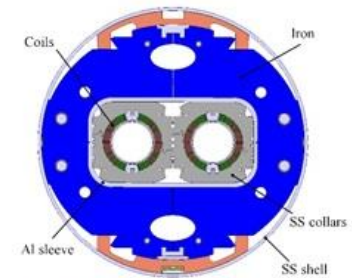

D2 [P. Fabbriatore, S. Farinon, et al.]

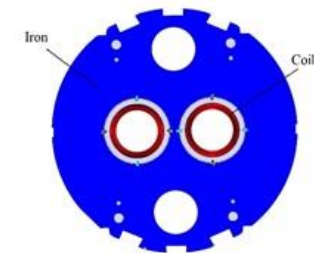

D2 correctors [G. Kirby]

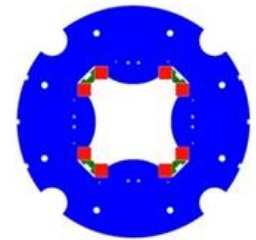

Skew quad [M. Sorbi, M. Statera, et al.]

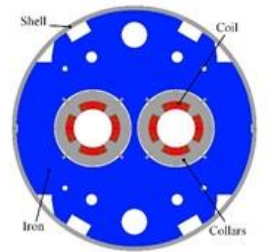

MQYY [H. Felice, et al.]



Dodecapole

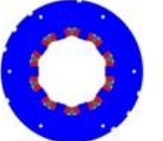

Decapole

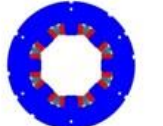

Octupole

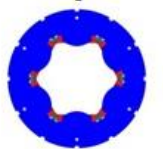

Sextupole

LHC, what next? FCC?

International FCC collaboration (CERN as host lab) to study:

80-100 km tunnel infrastructure

- pp -collider (*FCC-hh*)
- e^+e^- collider (*FCC-ee*) as potential first step
- $p-e$ (*FCC-he*) option

HE-LHC with *FCC-hh* technology

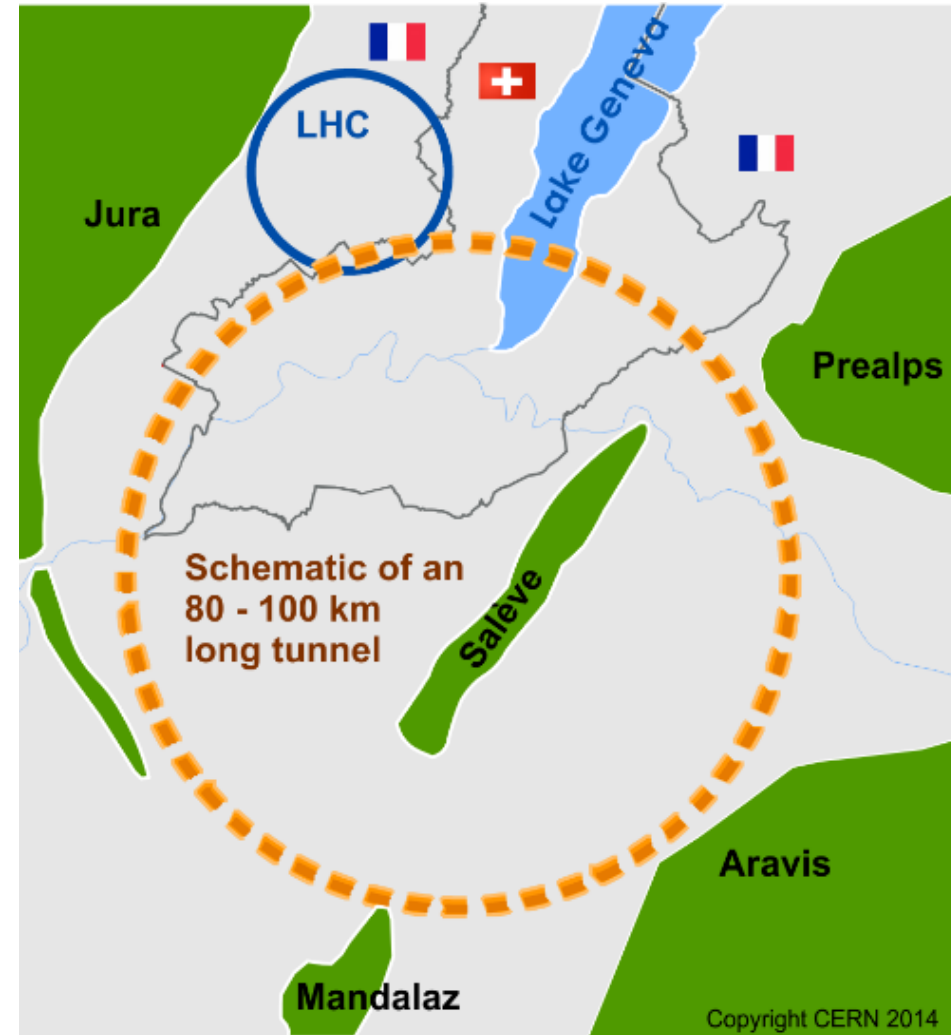
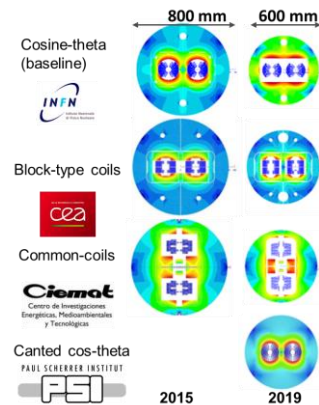
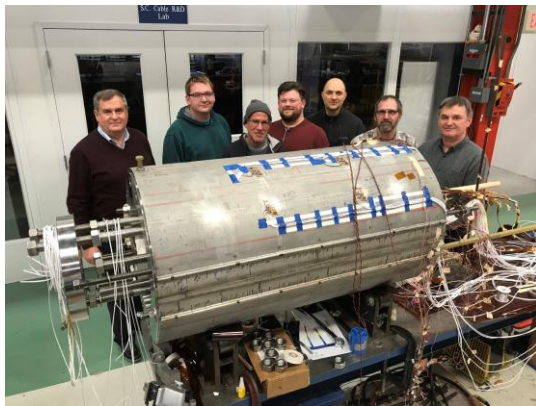

The HFM program

- High-field superconducting magnets (HFM) are a key technology for future accelerators, and can have a significant impact also on societal applications such as thermonuclear fusion, ultra-high-field magnetic resonance imaging (MRI), medical accelerators, other medical applications such as gantries, etc.
- This HFM R&D programme will be carried out within an expanded collaboration with research laboratories, institutes and industry in the Member States and beyond.
- A significant amount of the budget will be invested in industrial procurement and collaborations with European institutes.



MTP 2021-2030 allocation

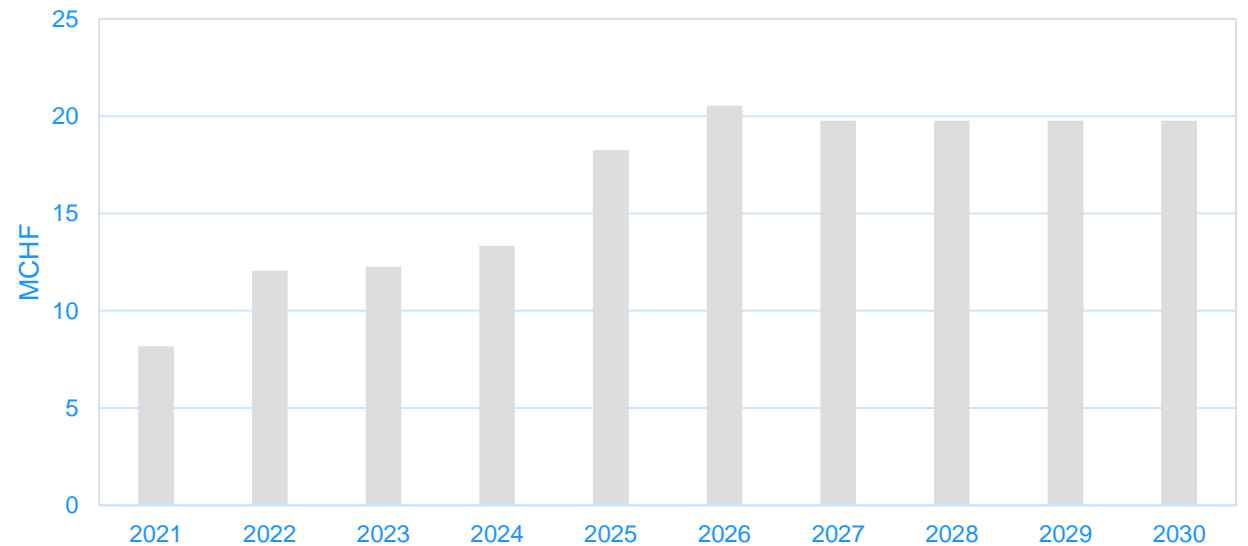

Future of HFM Development

Push Nb₃Sn magnet technology to its practical limit, both in terms of maximum performance as well as production scale

- 1. Develop Nb₃Sn magnets for collider-scale production**, through robust design, industrial processes and cost reduction
- 2. Demonstrate Nb₃Sn full potential** in terms of ultimate performance

Provide a proof-of-principle for HTS magnet technology beyond the reach of Nb₃Sn, and sufficient field quality for accelerator application

Concrete applications provide the opportunity to refine the functional specification for high-field magnets, including concerns around field quality requirements, ramping time and aperture form and diameter.

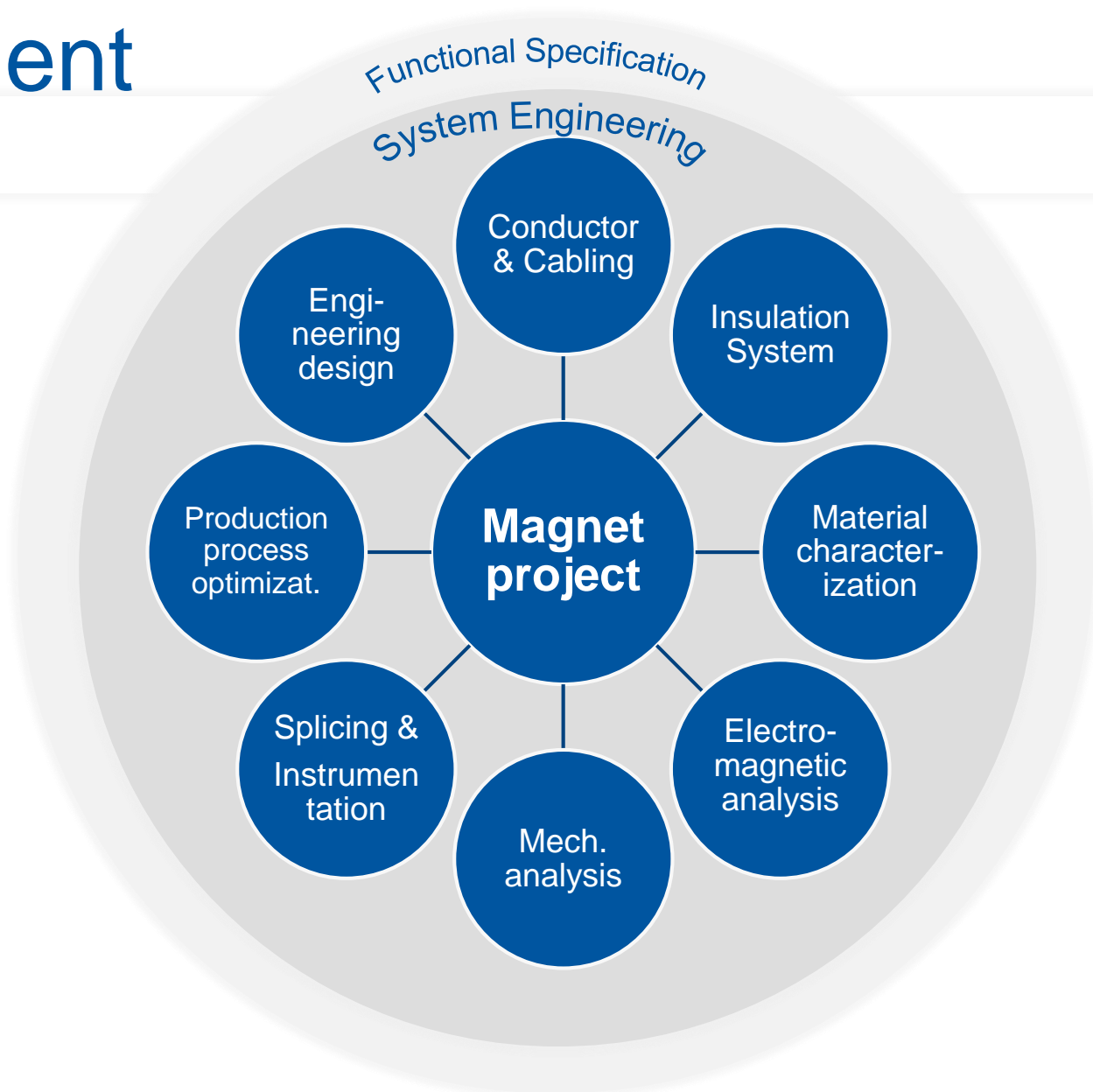

LHC what next? CLIC?

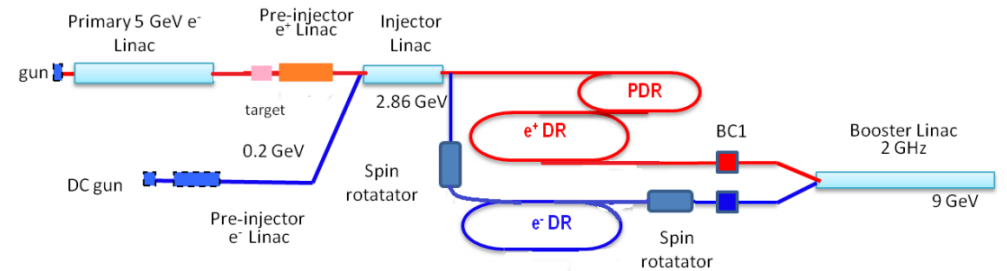
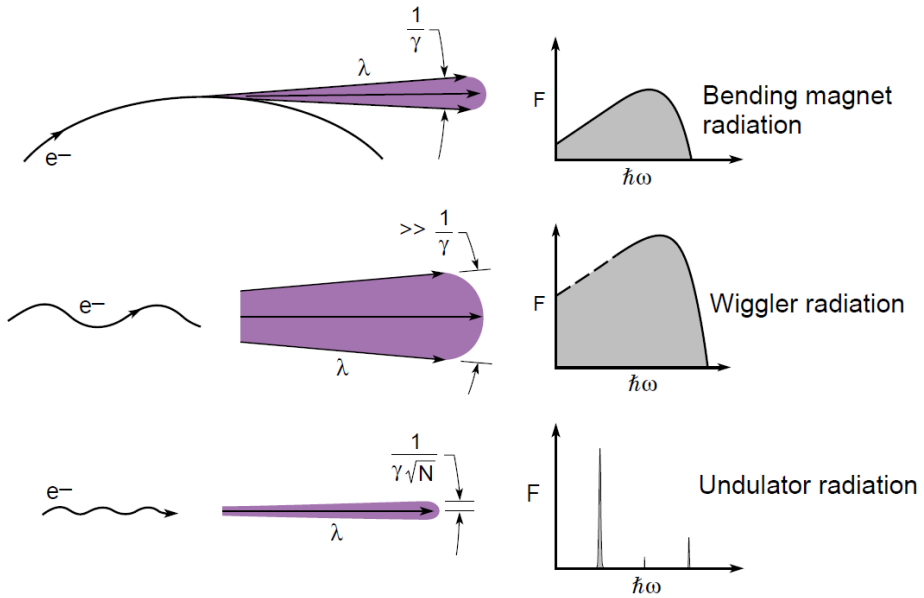
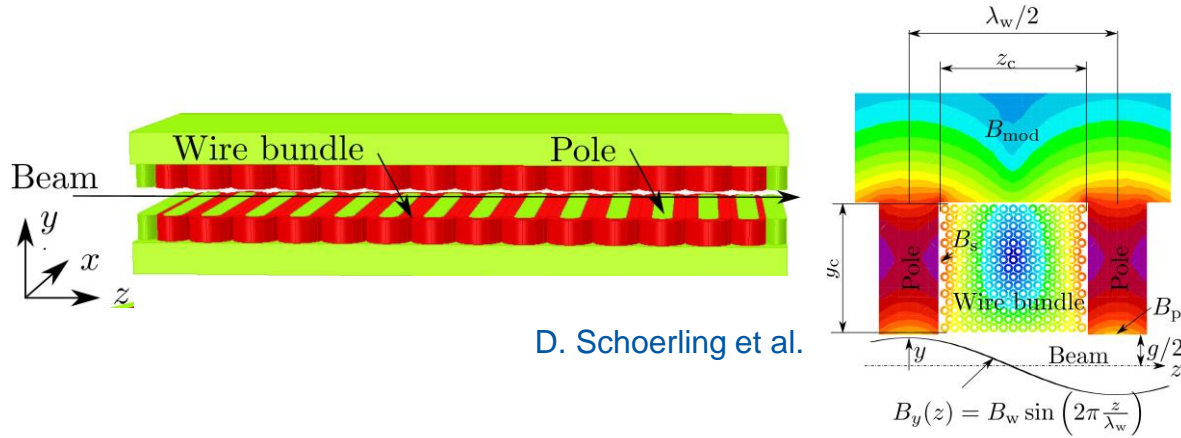

David Attwood, Soft X-Rays and Extreme Ultraviolet Radiation: Principles and Applications

High-Temperature Superconductors

- High-temperature superconductor promise much higher fields
- Technology is currently being developed
- Main challenge: Reduce cost!

Feather-M2

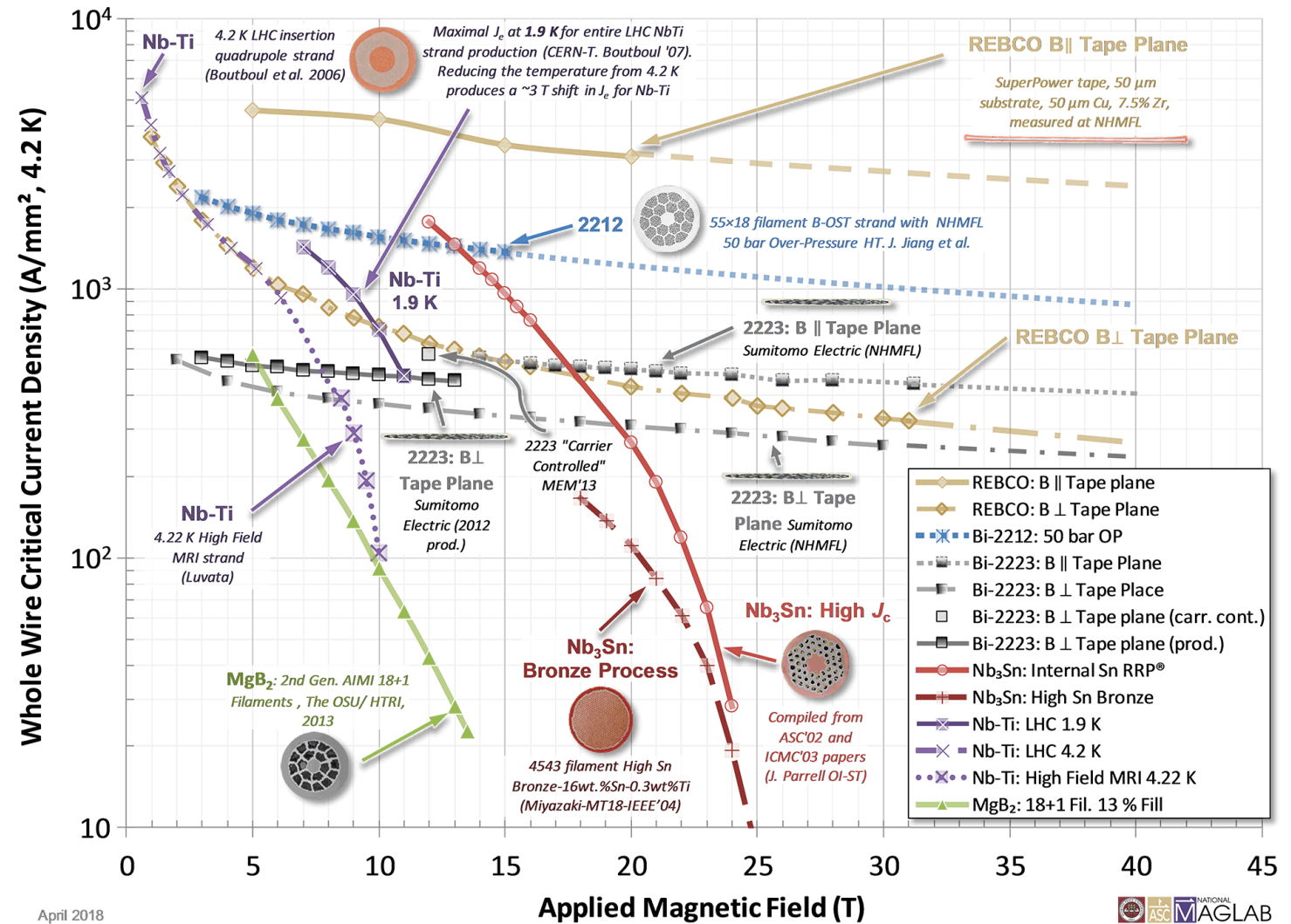
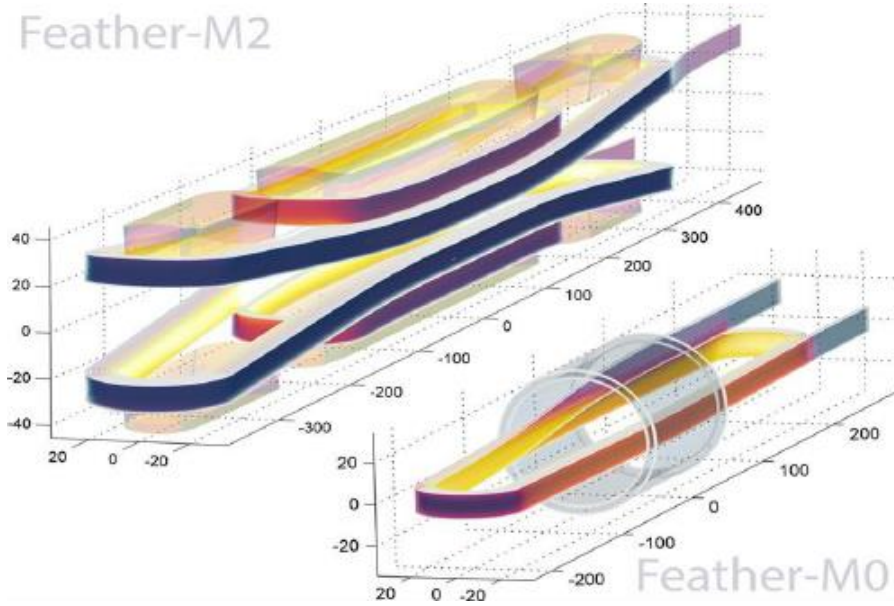

April 2018

Superconducting magnets

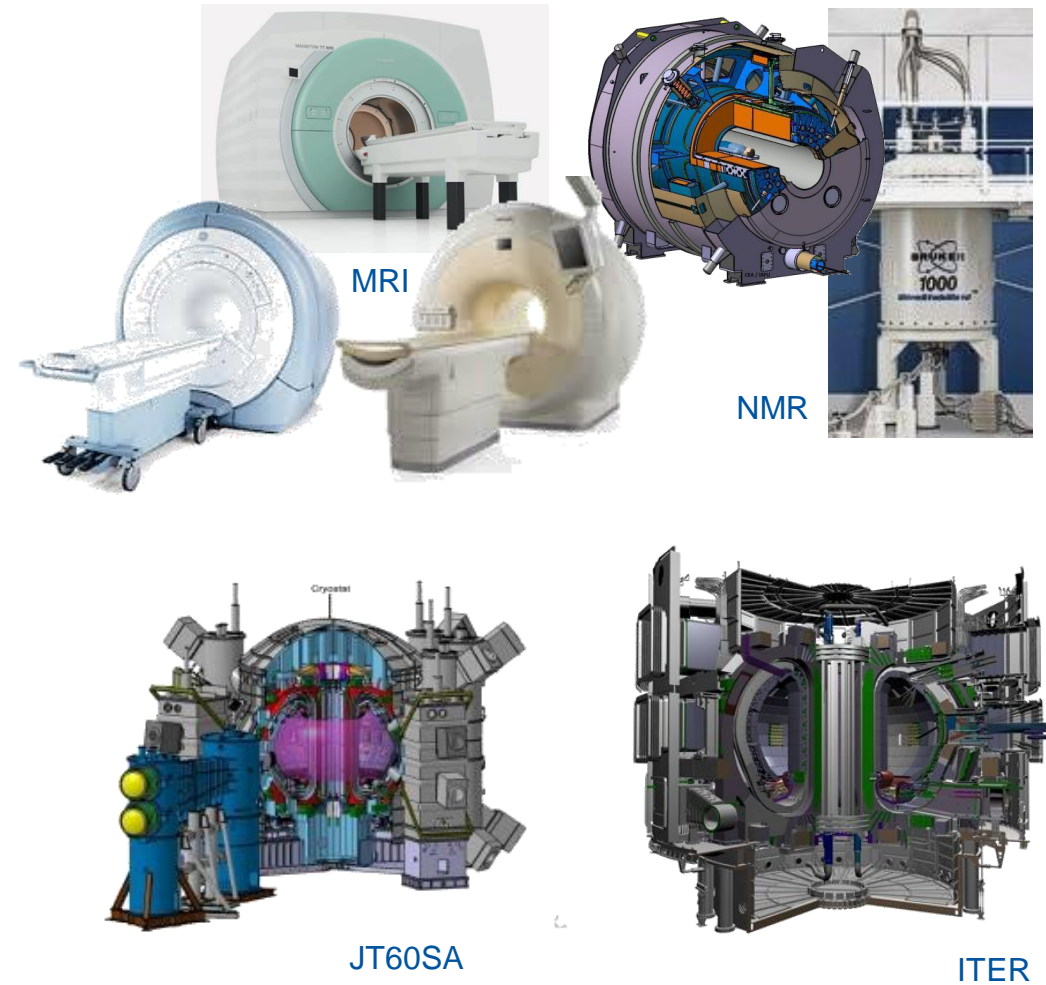
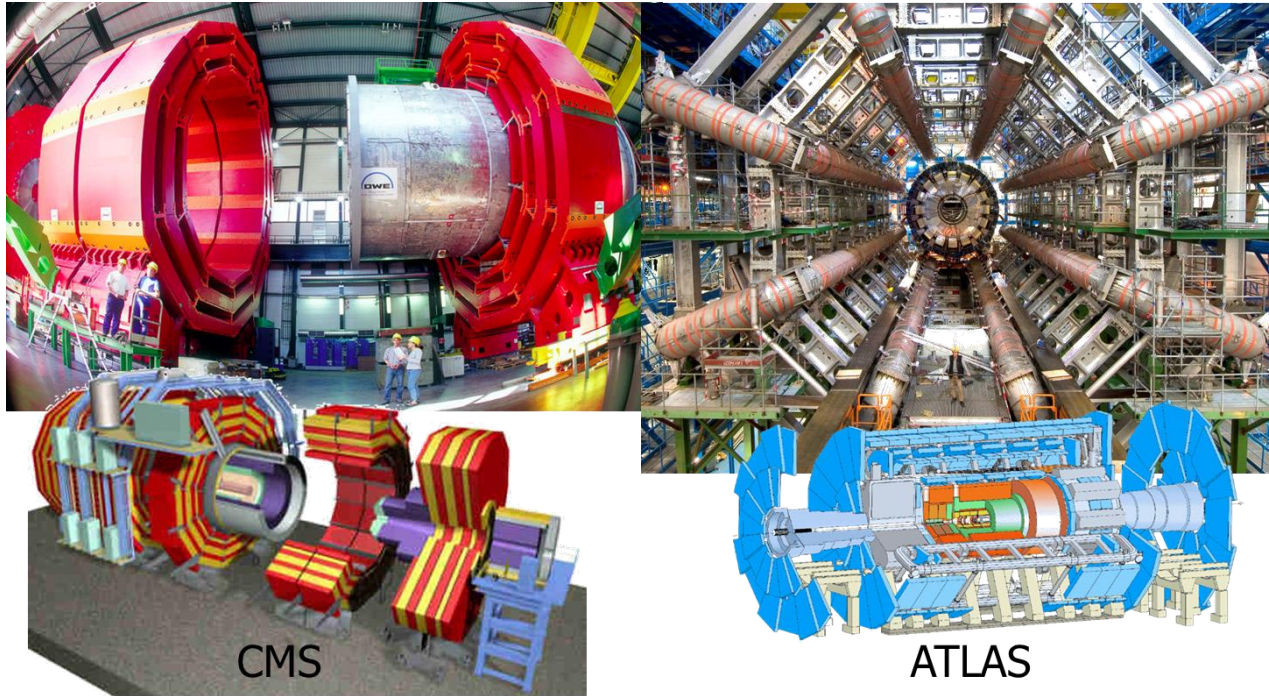

Concluding remarks

- Superconducting magnet design and manufacture is a very diverse field. It starts with superconductors (materials, wires, cables, and their electric and thermal properties), continues with electromagnetic design, thermal calculations, mechanics, protection, stability, etc...
- Cooling requires cryogenic, a field of applied science by its own
- The manufacture requires cost modelling, industrialization, complex project management, etc.
- To continue direction, establishing test beds with reduced turnaround times, to investigate observed limitations in processing Nb₃Sn and HTS magnets would be beneficial

Literature

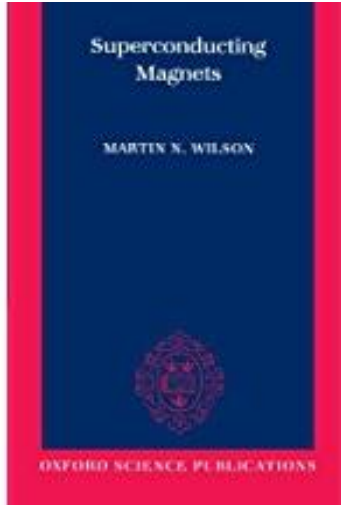

Martin N. Wilson, *Superconducting Magnets*, 1983, [link](#): The classical book! Excellent introduction to the engineering of superconducting magnets.

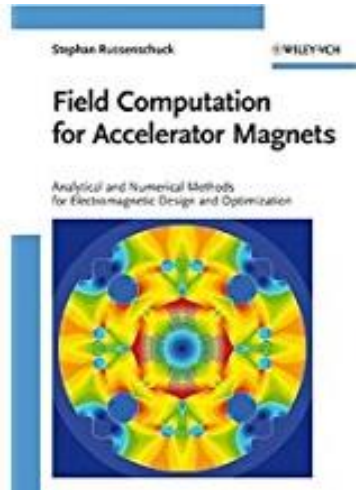

Stephan Russenschuck, *Field computation for Accelerator Magnets*, 2010, [link](#): The book for all questions related to electromagnetic calculations!

Literature

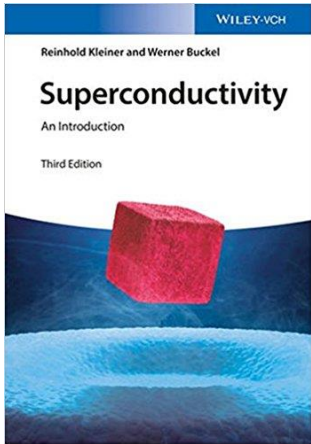

Werner Buckel and Reinhold Kleiner, *Superconductivity*, 2015, [link](#):
Very accessible and comprehensive introduction to superconductivity!

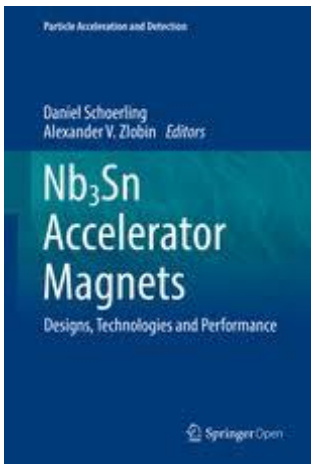

Daniel Schoerling and Alexander V. Zlobin, *Nb₃Sn accelerator magnets: Designs, technologies, and performance*, 2019, [link](#): Review of all so far built Nb₃Sn dipole magnets.