

RF Systems I



H. Damerou
CERN



Basic CAS Extension

29 June 2021

Copyright statement and speaker's release for video publishing

The author consents to the photographic, audio and video recording of this lecture at the CERN Accelerator School. The term “lecture” includes any material incorporated therein including but not limited to text, images and references.

The author hereby grants CERN a royalty-free license to use his image and name as well as the recordings mentioned above, in order to broadcast them online to all registered students and to post them without any further processing on the CAS website.

The author hereby confirms that the content of the lecture does not infringe the copyright, intellectual property or privacy rights of any third party. The author has cited and credited any third-party contribution in accordance with applicable professional standards and legislation in matters of attribution.

Outline

- **Introduction**
- **Choice of parameters**
 - Frequency and voltage
- **RF cavity parameters**
 - Shunt impedance, beam loading, power coupling
- **Power amplifiers**
 - Tube or solid state
 - Local feedbacks
- **Longitudinal beam control system**
 - Building blocks: RF source and receiver
 - Phase, radial and synchronization loops
- **Summary**

Introduction

Introduction

- The **radiofrequency (RF)** system transforms a string of magnets into an **accelerator**
- Cavity most is the most visible part of an RF system
 - On top of the RF system **food chain**
 - Interacts directly with beam

→ What is below?

→ How are RF signals generated which make the beam feel comfortable?

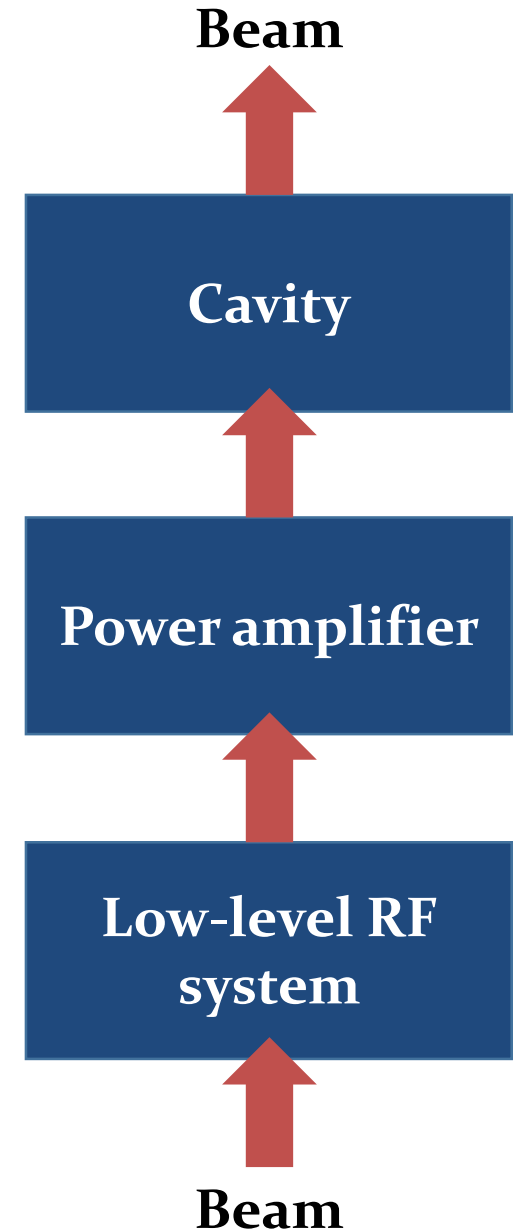

Frequency and wavelength ranges



PS longitudinal damper



PS main RF system

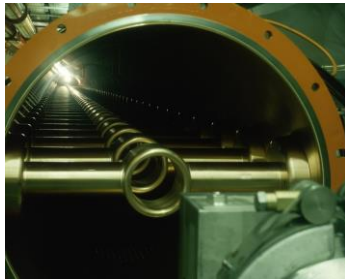

SPS 200 MHz

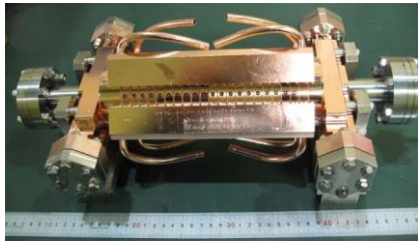

CLIC 12 GHz



Long wave

**Medium/
short wave**



VHF



**Microwave
links**



Amplitude ranges

Signals from beam pick-ups

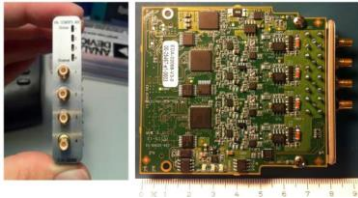

LLRF systems

Low/Medium energy hadron RF

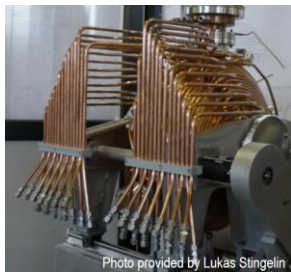
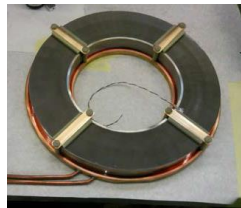

SLS



LHC: 16 MV



LEP: 3.6 GV total

1 μ V

1 mV

1 V

1 kV

1 MV

1 GV

Cooled hadron beams (ELENA)

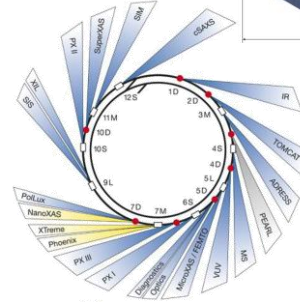
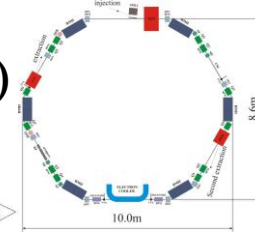

LHC

Electron light sources

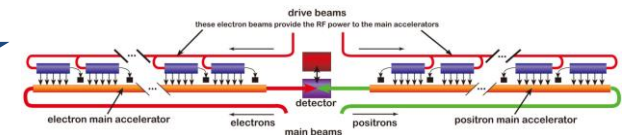
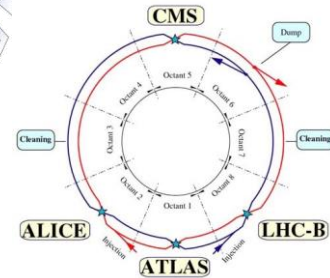

ILC and CLIC: several TV

Particle velocity

- Particle velocity depends on its type: $\beta = v/c = \sqrt{1 - (E_0/E)^2}$

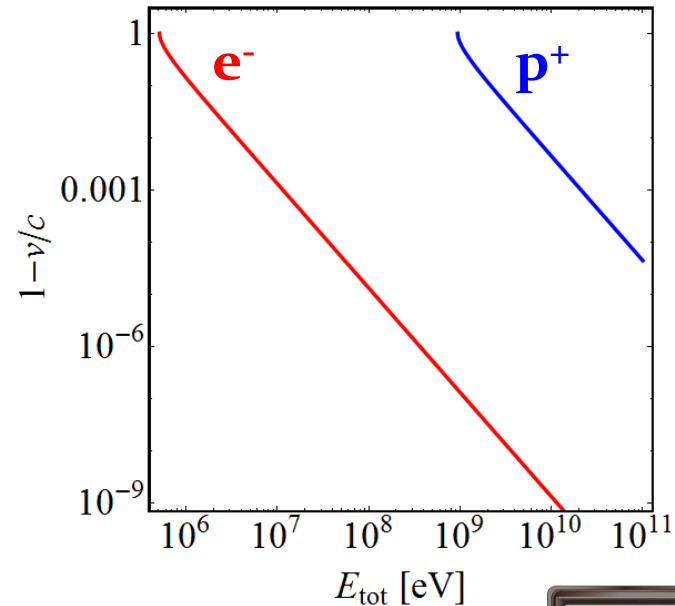
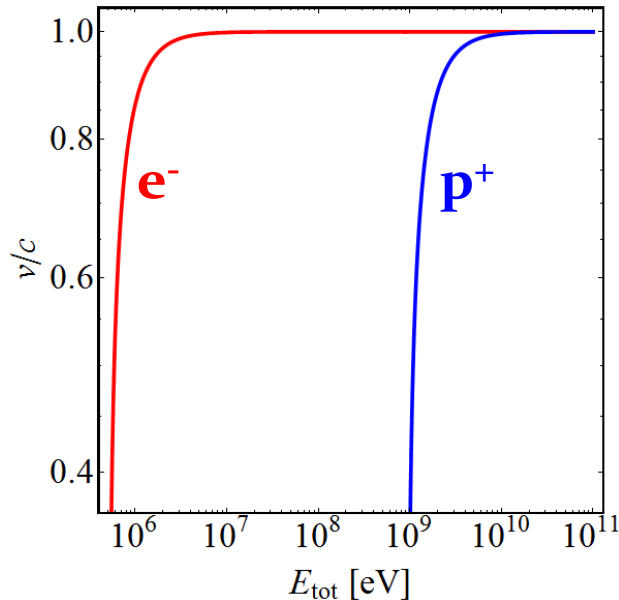

- Old television set (30 kV): **Electrons** at 30% of c_0
Protons just at 0.7%
- Small synchrotron (500 MeV): **Electrons** at 99.99995%
Protons at 75.8%

→ Most electron accelerators at 'fixed' frequency

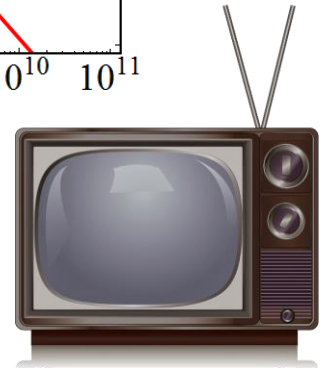

Parameter choices

RF system for high-energy accelerators

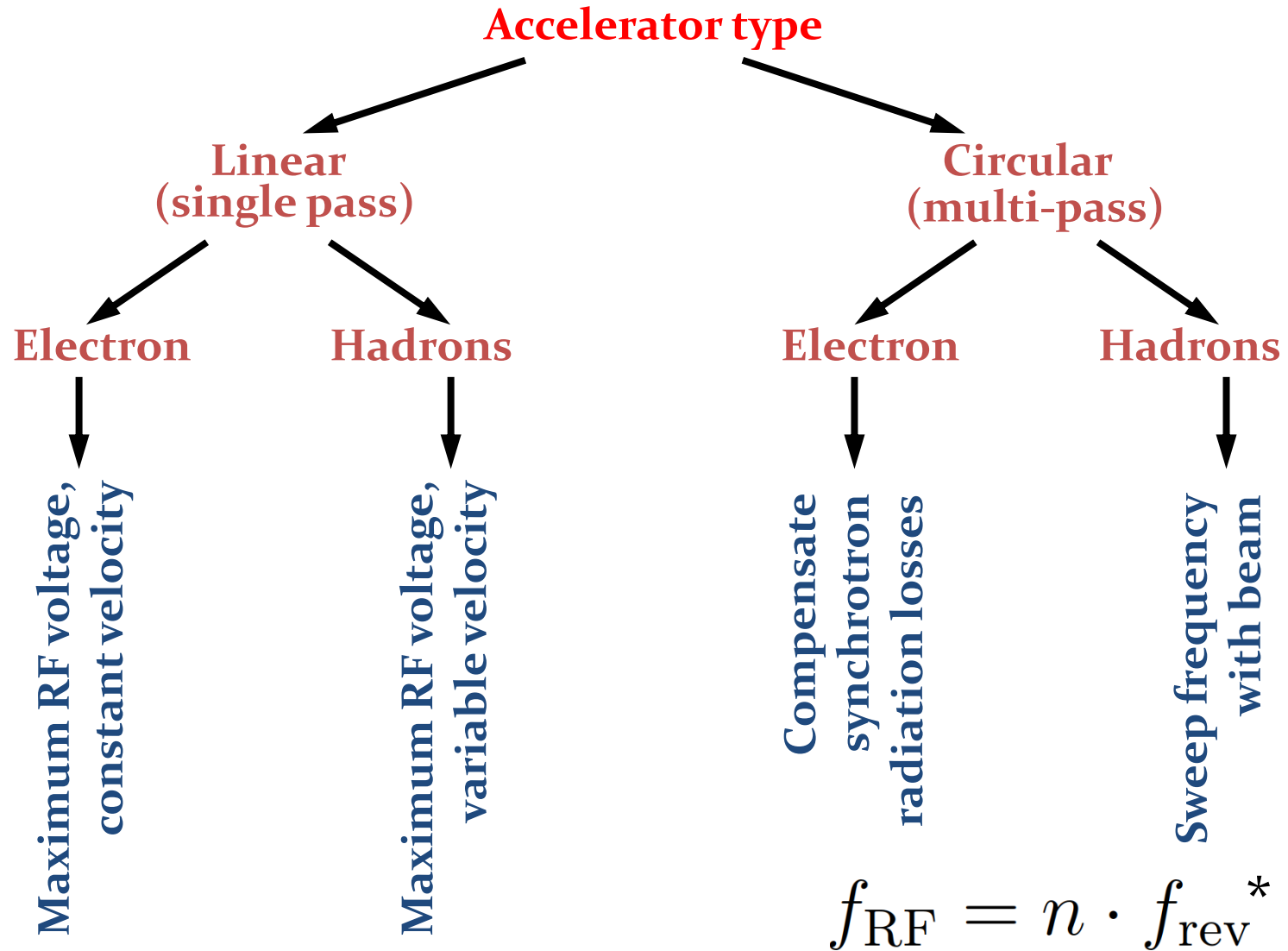

*Exceptions (rare) exist

Choice of frequency (range)

Why choose a **low** RF frequency?

Advantages	Disadvantages
<ul style="list-style-type: none"> • Large beam aperture • Long RF buckets, large acceptance • Wide-band or wide range tunable cavities possible • Power amplification and transmission straightforward 	<ul style="list-style-type: none"> • Bulky cavities, size scales $\propto 1/f$, volume $\propto 1/f^3$ • Lossy material to downsize cavities • Moderate or low acceleration gradient • Short particle bunches difficult to generate

RF frequencies **below**
~200 MHz for



- **Some hadron linear accelerators**
- **Cyclotrons**
- **Low- and medium energy hadron synchrotrons**

Why choose a **high** RF frequency?

Advantages	Disadvantages
<ul style="list-style-type: none">• Cavity size scales $\propto 1/f$, volume $\propto 1/f^3$• Break down voltage increases• High gradient per length• Particle bunches are short	<ul style="list-style-type: none">• Maximum beam available aperture scales $\propto 1/f$• No technology for wide-band or tunable cavities• Power amplifiers more difficult• Power transmission losses
<p>RF frequencies above ~200 MHz used for</p>	 <ul style="list-style-type: none">→ Linear accelerators→ Electron storage rings→ High energy hadron storage rings

Limits to maximum gradient

- Surface electric field in vacuum

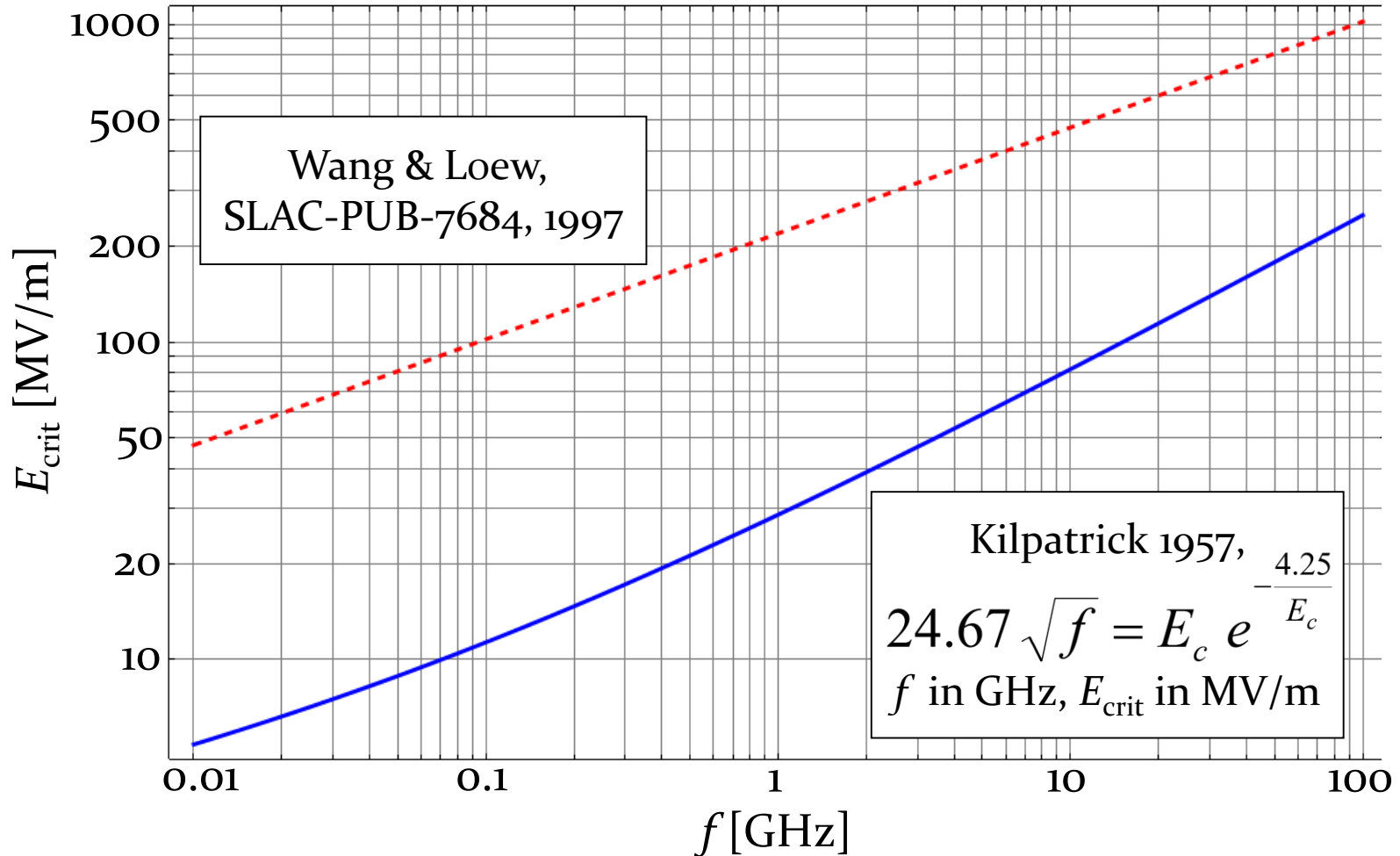

→ High frequencies preferred for large gradient

Some standard frequencies

If exact RF frequency not critical, choose standard value

Accelerator	Frequency
Hadron synchrotrons (PSB, PS, JPARC RCS, MR)	<10 MHz
Hadron accelerators and storage rings (RHIC, SPS)	~200 MHz
Electron storage rings (LEP, ESRF, Soleil)	352 MHz
Electron storage rings (DORIS, BESSY, SLS,...)	499.6...499.8 MHz
Superconducting electron linacs and FELs (X-FEL, ILC)	1300 MHz
Normal conducting electron linacs (SLAC)	2856 MHz
High-gradient electron linac (CLIC)	11.99 GHz

- **Off-the-shelf RF components easily available in frequency ranges used by industry**
- **Exchange of developments and equipment amongst research laboratories**

RF voltage

Minimum voltage requirement

- RF system expected to provide given energy gain

$$qV = \Delta E$$

- On-crest acceleration
- Used in some linear accelerators
- **Insufficient in a circular accelerator**

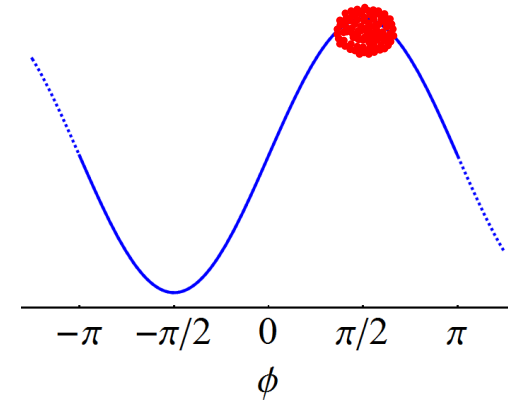

- More voltage provided to avoid on-crest acceleration

$$qV > \Delta E \rightarrow qV \sin(\phi_S) = \Delta E$$

- Off-crest acceleration
- Needed for circular accelerator
- **Higher voltage for given energy gain**

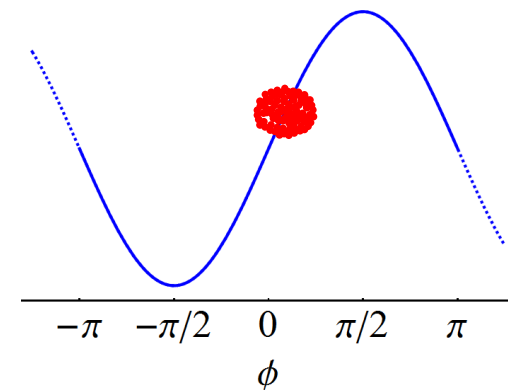

Bucket area dependence on stable phase

- In a circular accelerator the area in energy-time phase space (bucket area) depends on the stable phase

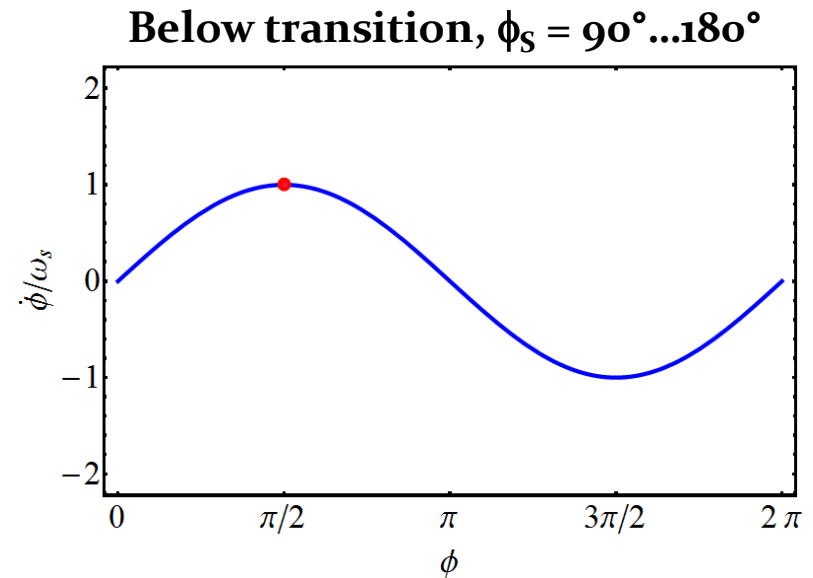
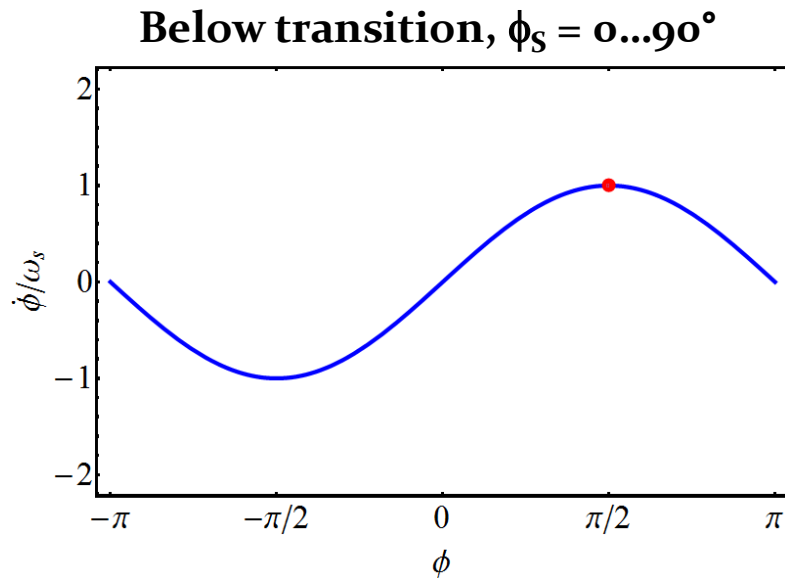

- Typical synchronous phase with respect to 0° or 180°
 - Hadron accelerators: $< 40^\circ$
 - Electron storage rings: $\sim 20^\circ$

Minimum voltage requirement (circular)

The RF system must compensate

1. Energy gain per turn due to changing magnetic field

$$F_Z = F_L \quad \rightarrow \quad \frac{p}{q} = \rho B \quad \rightarrow \quad \dot{p} = q\rho\dot{B}$$

$$\dot{p} = \frac{\Delta p}{\Delta t} = \frac{m_0 c^2 \beta}{2\pi R} (\beta \Delta \gamma + \gamma \Delta \beta) = \frac{\Delta E_{\text{turn}}}{2\pi R}$$

$$\Delta E_{\text{turn}} = 2\pi q \rho R \dot{B}$$

2. Energy loss, e.g., due to synchrotron radiation (electrons)

$$\Delta E_{\text{turn}} = \frac{e^2}{3\epsilon_0 (m_0 c^2)^4} \frac{E^4}{\rho}$$

$$\Delta E_{\text{turn}}[\text{keV}] = 88.5 \cdot \frac{E^4[\text{GeV}]^4}{\rho[\text{m}]} \quad \Delta P_{\text{loss}}[\text{kW}] = 88.5 \cdot \frac{E^4[\text{GeV}]^4}{\rho[\text{m}]} \cdot I_B[\text{A}]$$

$\rightarrow (m_p/m_e)^4 = 1836^4 \sim 1.1 \cdot 10^{13}$ times less for protons

RF system overview

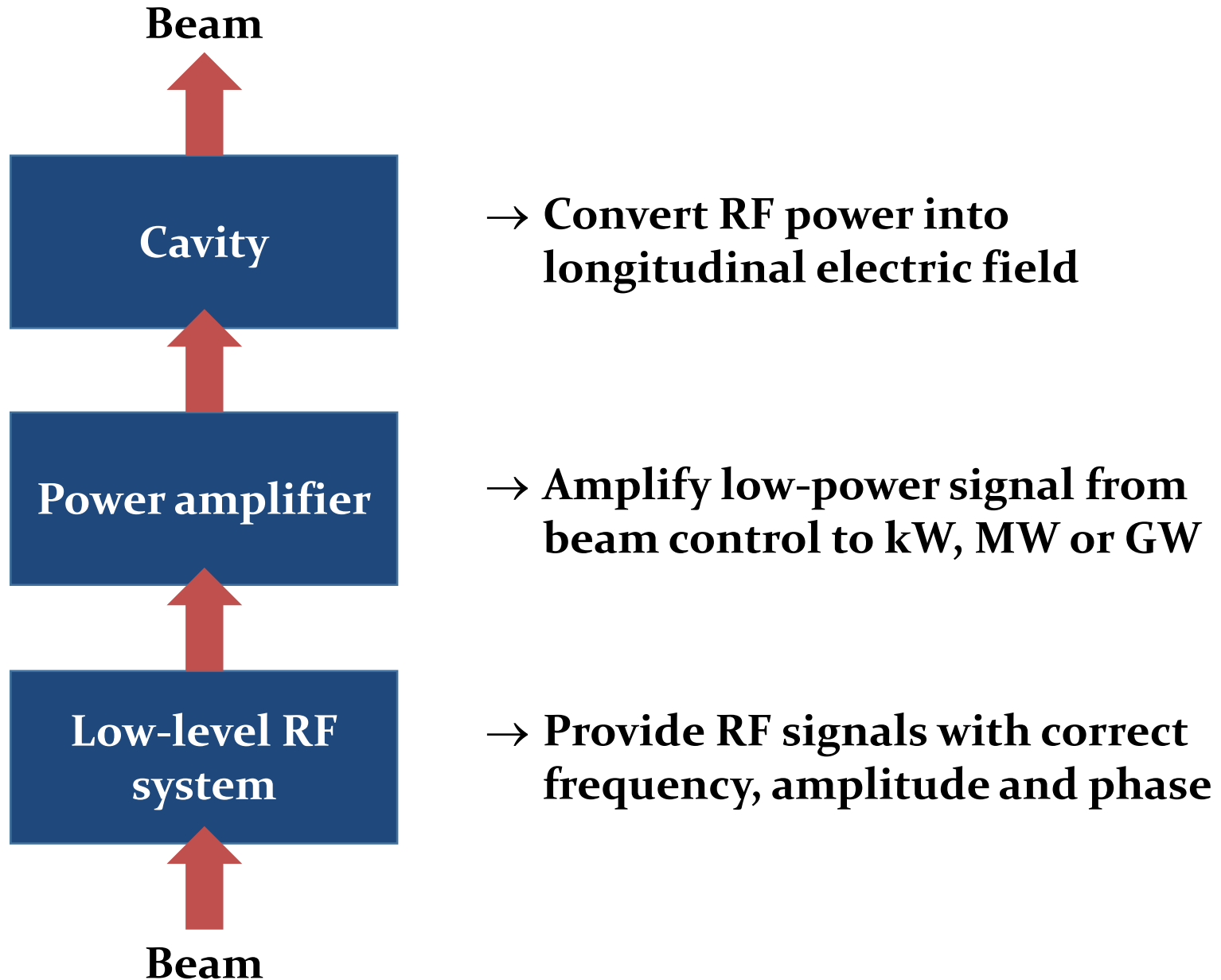

RF system overview

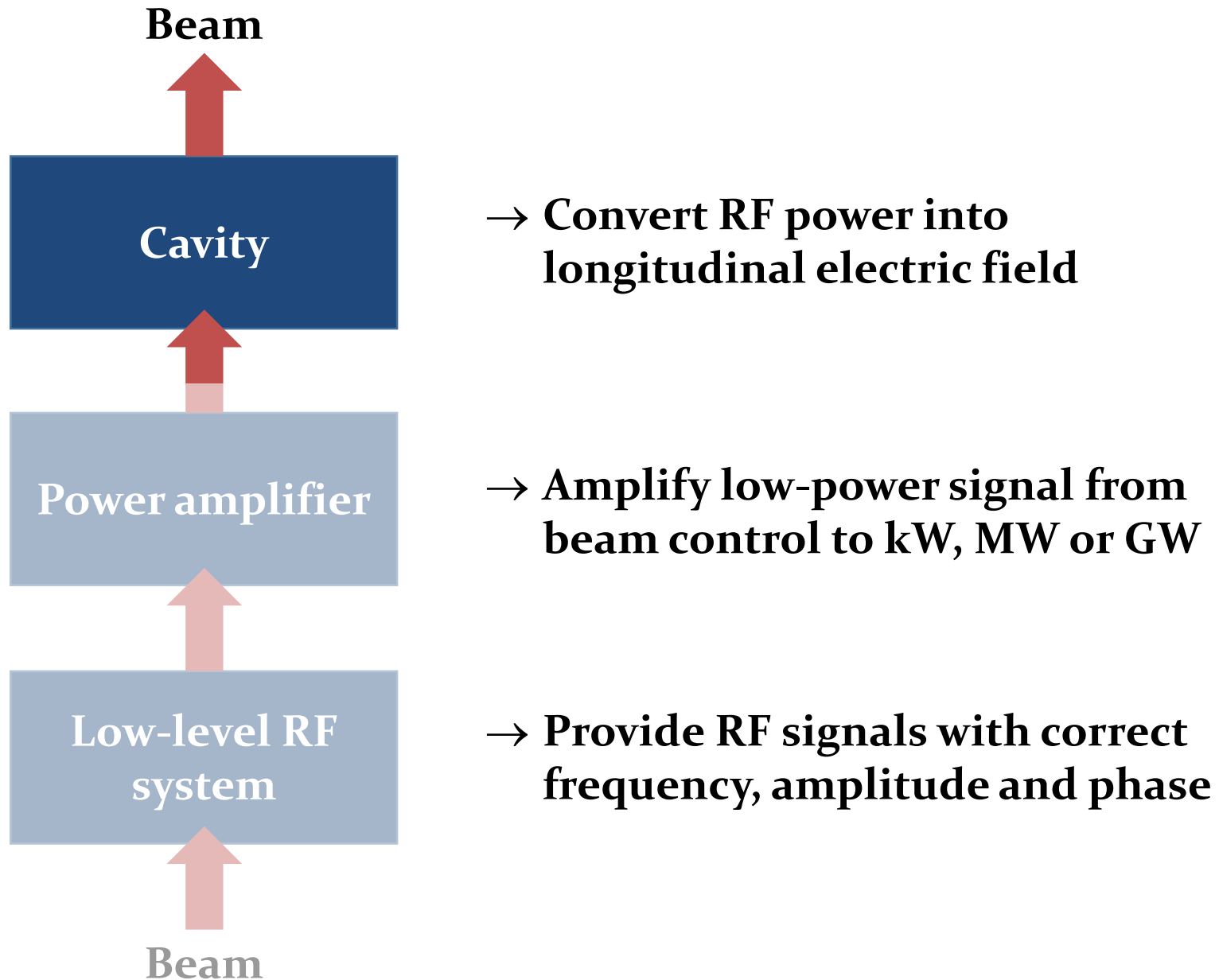

RF cavity

Cavity parameters

- The resonance of a cavity can be understood as simple parallel resonant circuit described by R, L, C

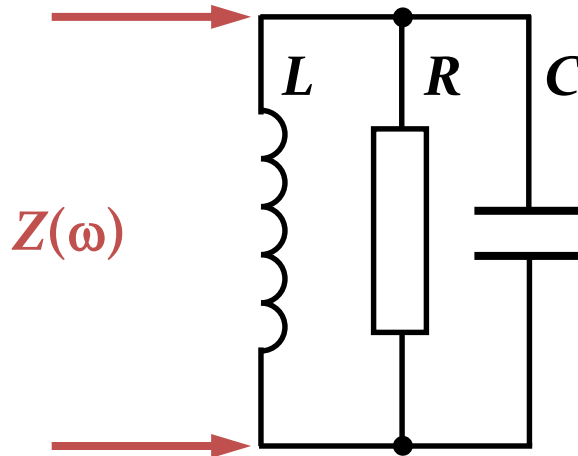

$$\frac{1}{Z(\omega)} = \frac{1}{R} + \frac{1}{i\omega L} + i\omega C$$

with
$$\omega_0 = \frac{1}{\sqrt{LC}}$$

$$Q = \omega_0 \frac{\text{Stored energy}}{\text{Average power loss}} = \frac{\omega_0 E}{P}$$

$E = \frac{1}{2} CV^2 = \frac{1}{2} LI^2$
 $P = \frac{1}{2} \frac{U^2}{R} = \frac{1}{2} I^2 R$

$$Q = \omega_0 RC = \frac{R}{\omega_0 L}$$

Cavity parameters

- The resonance of a cavity can be understood as simple parallel resonant circuit described by R, L, C

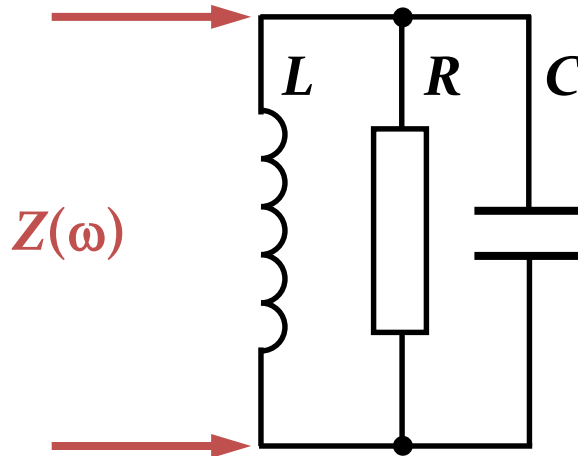

$$\frac{1}{Z(\omega)} = \frac{1}{R} + \frac{1}{i\omega L} + i\omega C$$

with $\omega_0 = \frac{1}{\sqrt{LC}}$

$$Q = \omega_0 RC = \frac{R}{\omega_0 L} \quad Z(\omega) = \frac{R}{1 + iQ \left(\frac{\omega^2 - \omega_0^2}{\omega\omega_0} \right)} \approx \frac{R}{1 + 2iQ \frac{\Delta\omega}{\omega_0}}$$

- Resonant circuit can also be described by $R, R/Q, \omega_0$ or any other set of three parameters

Cavity parameters

- The resonance of a cavity can be understood as simple parallel resonant circuit described by R , L , C

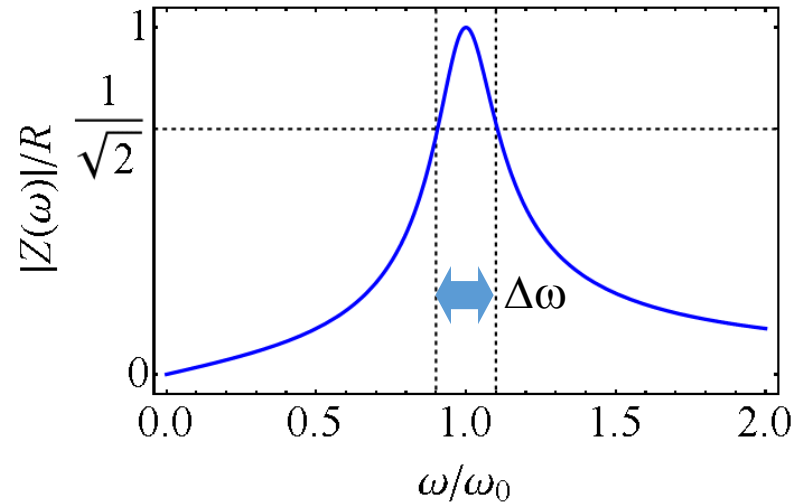
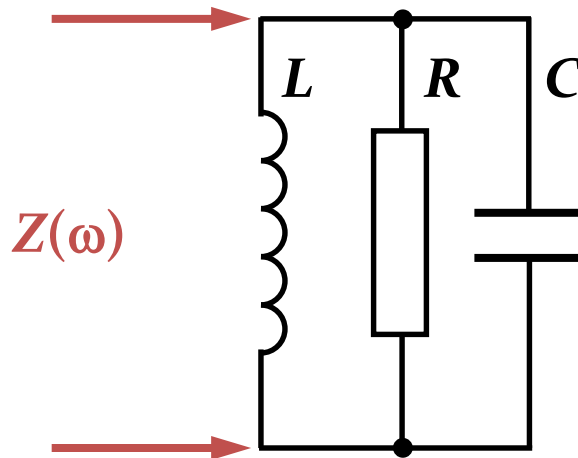

$$Q = \omega_0 RC = \frac{R}{\omega_0 L} \quad Z(\omega) = \frac{R}{1 + iQ \left(\frac{\omega^2 - \omega_0^2}{\omega \omega_0} \right)} \approx \frac{R}{1 + 2iQ \frac{\Delta\omega}{\omega_0}}$$

- Resonant circuit can also be described by R , R/Q , ω_0 or any other set of three parameters

Cavity parameters

- Most common choice by cavity designers ω_0 , R , R/Q – why?
- **Resonance frequency, ω_0**
 - Exactly defined for given application, e.g. hf_{rev}
- **Shunt impedance, R**
 - Power required to produce a given voltage **without beam**
- **“R-upon-Q”, R/Q**
 - Defined only by the cavity geometry
 - Criterion to optimize a geometry
 - Detuning with beam proportional to R/Q

Why R/Q?

→ Charged particle experiences cavity gap as capacitor

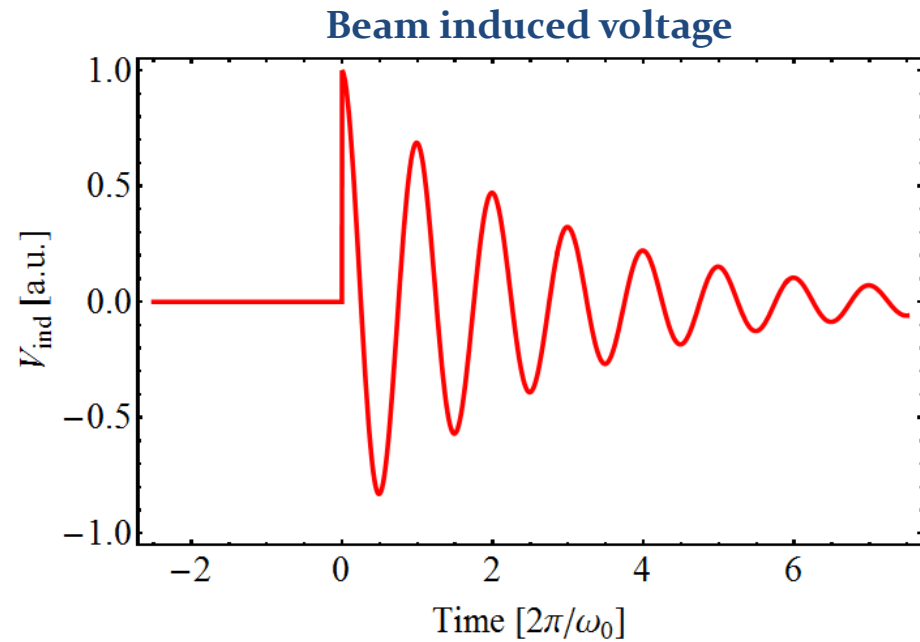
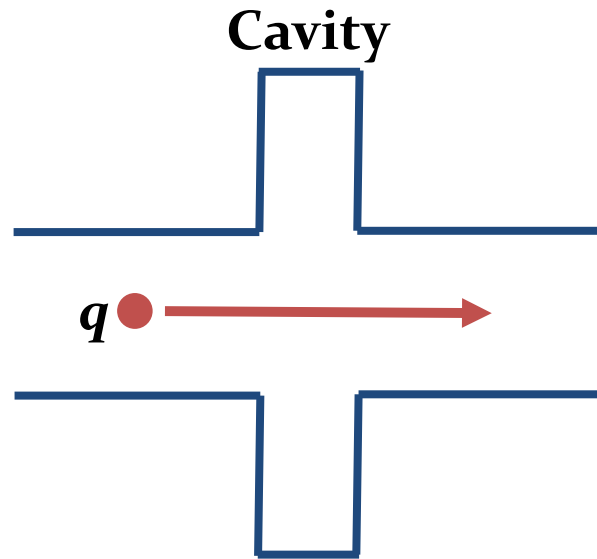

$$q = V_{\text{ind}} C$$

$$Q = \omega_0 RC \quad \rightarrow \quad \frac{1}{C} = \left(\frac{R}{Q} \right) \omega_0$$

$$V_{\text{ind}} = \frac{q}{C} \propto \frac{R}{Q}$$

→ Cavity geometry with small R/Q to reduce beam loading

RF cavities in low frequency range

- **RF wavelength large below ~10 MHz: >30 m**
- Would need huge cavities → too large for accelerators
- Line resonators: **$\lambda/4$ resonator**

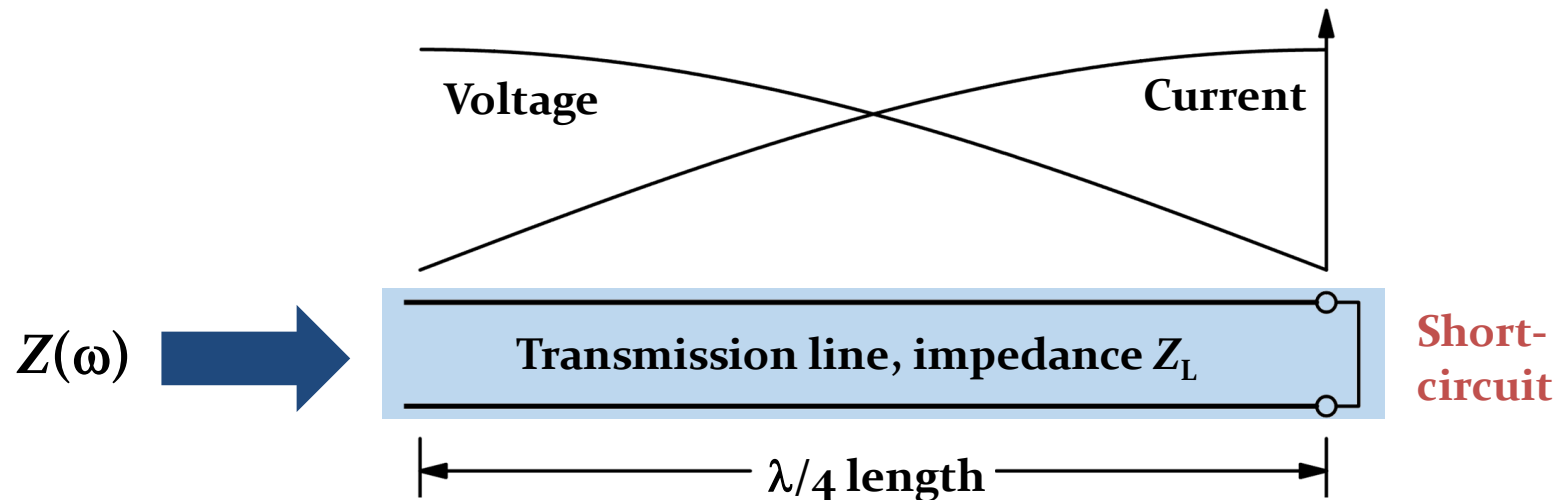

- Short circuit on one side
- Open end on other
- Voltage is zero
- No current but voltage

Why is this resonator so common in particle accelerators?

RF cavities in low frequency range

- Coaxial structure with inner conductor as beam pipe

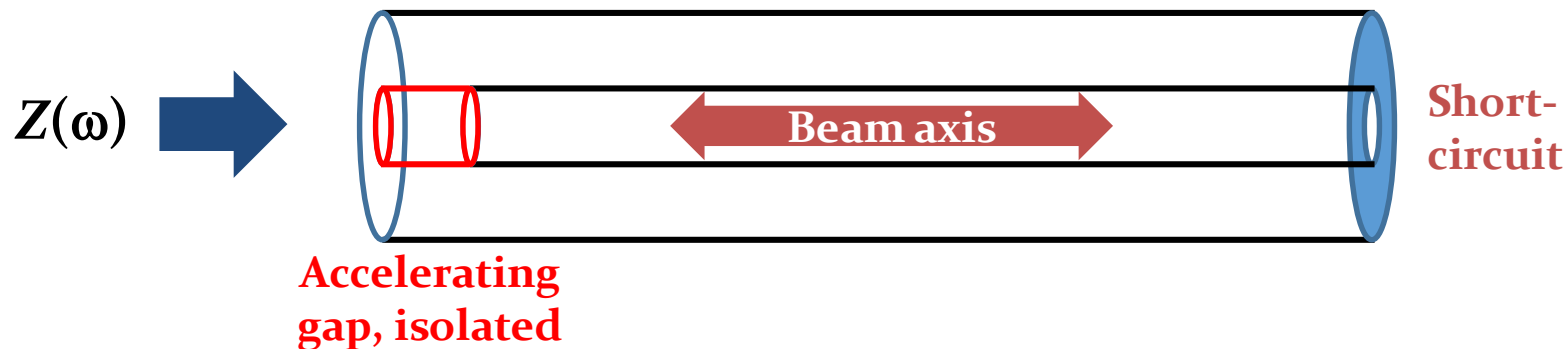

→ Still rather long geometry, 7.5 m at 10 MHz

→ Add capacitive or inductive shortening

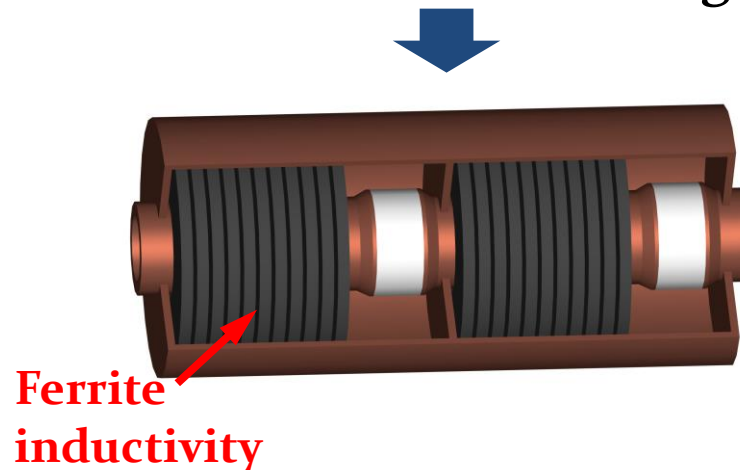
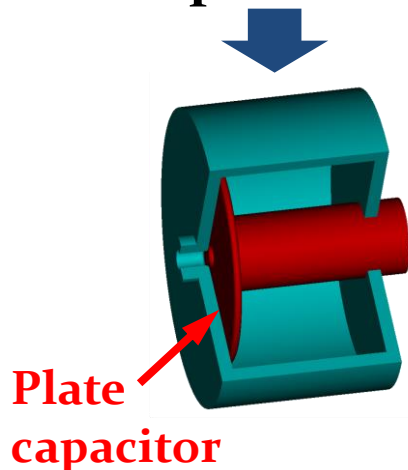

Capacitive loading

→ Add capacitor at gap of cavity to shorten the resonator

NSLS, 52.88 MHz

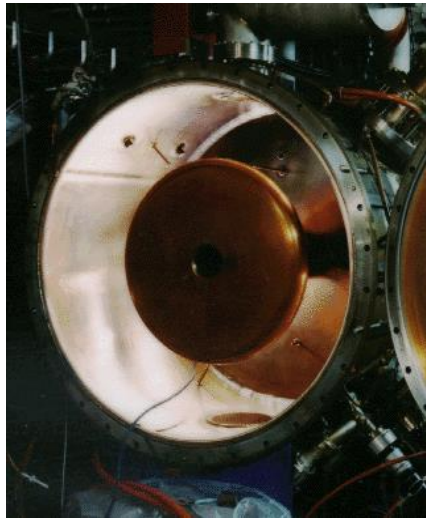

DESY PIA, 10.4 MHz, inner cond.

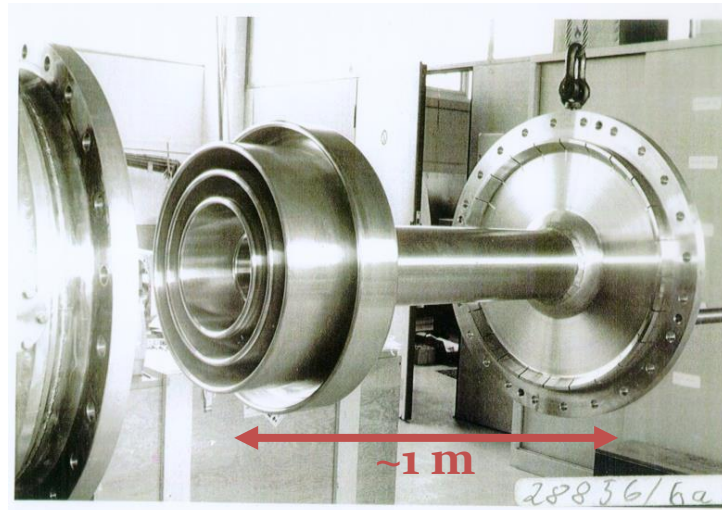

Outer cond.

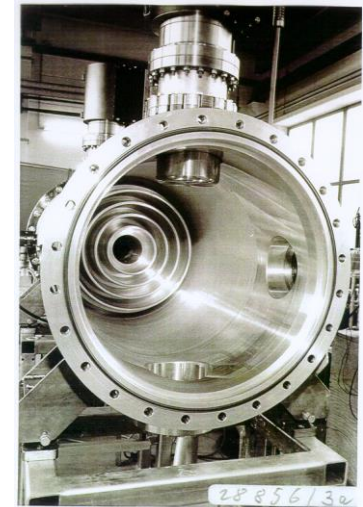

ACOL, 9.53 MHz

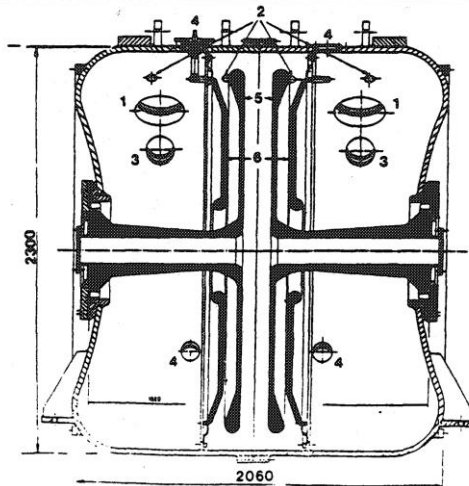

- Significantly reduces cavity size
- Fixed frequency only
- Small losses due to capacitor
- Cavity in vacuum

Inductive loading

- Inductive loading with magnetic material shortens resonator from tens of meters to a device, **lossy though**

CERN PSB Finemet cav., 0.6-18 MHz

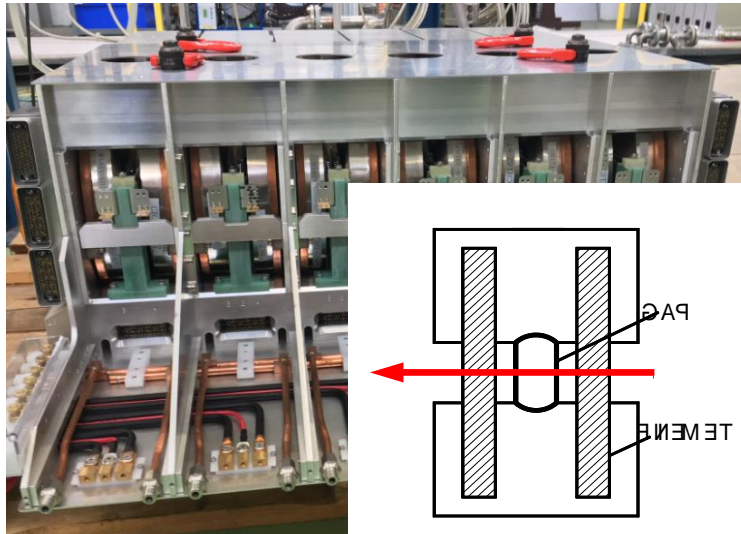

CERN PS, double gap, 2.8-10 MHz

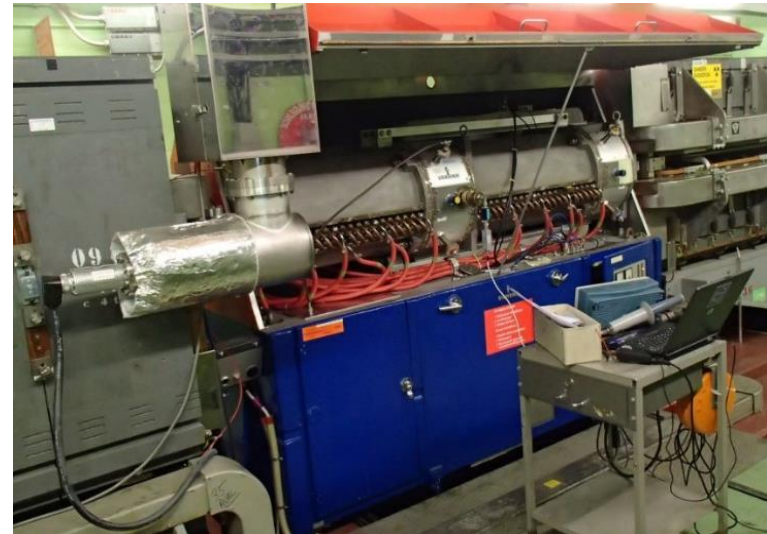

M. Paoluzzi

- Additional advantage: permeability of ferrite can be controlled by DC bias current → **variable inductivity**
 - Cavity with programmable resonance frequency
 - Essential for hadron acceleration in low-energy accelerators

Tunable cavities at higher frequencies

→ Remove inductive or capacitive loading

SSC Low Energy Booster,
~47 MHz to 60 MHz

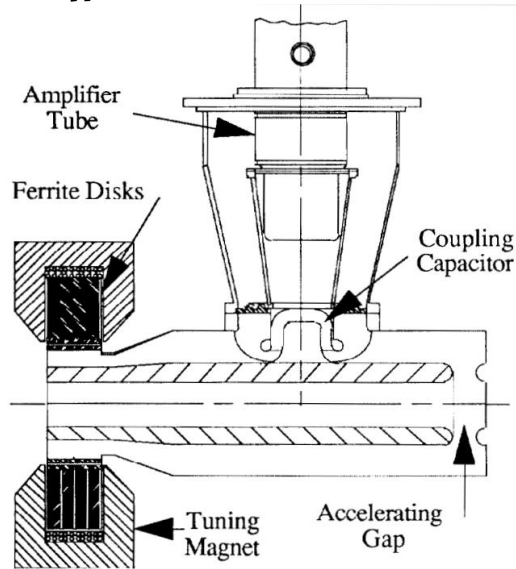

C. C. Friedrichs et al., PAC91, p. 1020

FNAL Booster 2nd harmonic,
76 MHz – 106 MHz, 100 kV

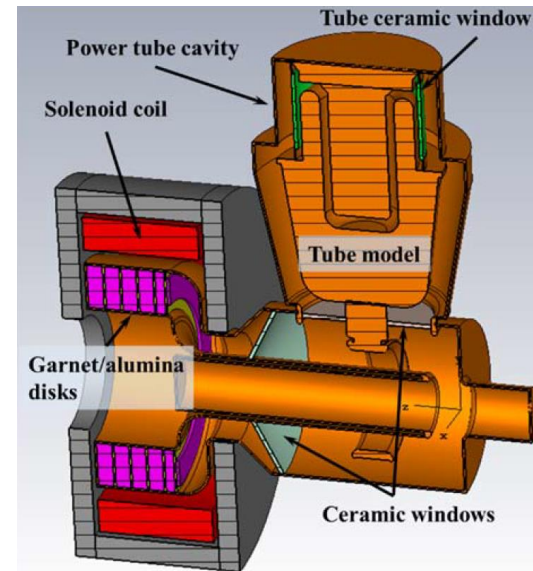

R. L. Madrak, IPAC16, p. 130

→ Upper frequency limit for cavities with large tuning range

Further increase frequency

→ Remove inner conductor from coaxial set-up



→ The resonator becomes a pill-box cavity
DORIS cavity

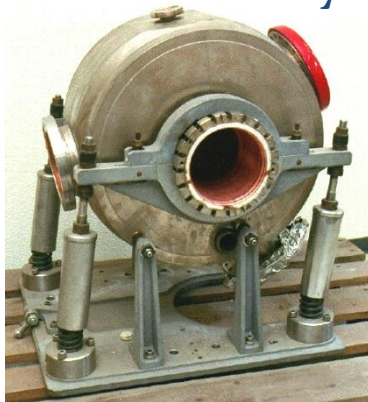

Electric field,
 TM_{010} -mode

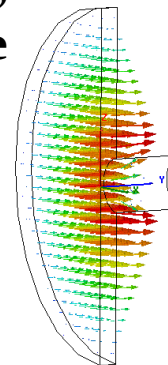

Magnetic field,
 TM_{010} -mode

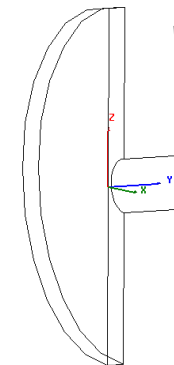

E. Jensen

→ The basis for cavity resonators

Example: 400 MHz cavities in LHC

- Reduce beam loading in RF cavities
- Shunt impedance, R , low for small R/Q with normal conducting cavities → superconducting cavities in LHC

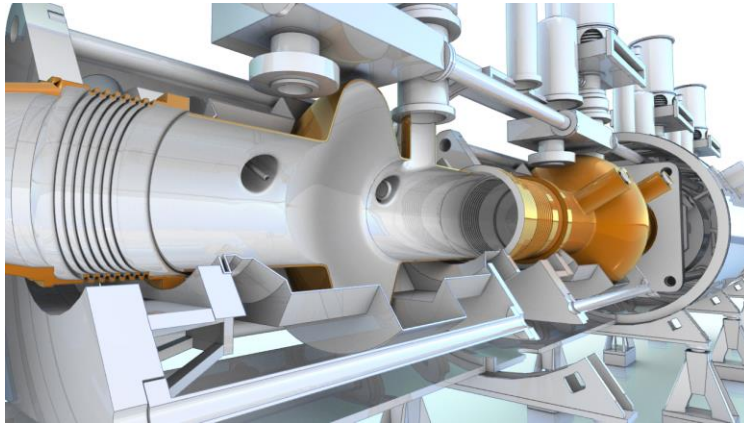

Bell shape: $R/Q \sim 44 \Omega$, 400 MHz

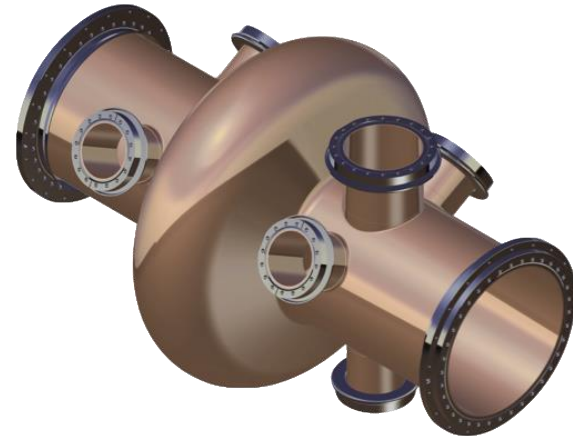
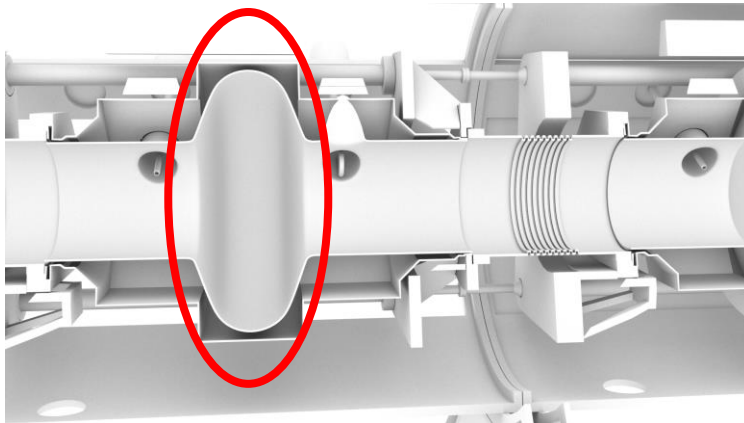

→ 2×8 cavities, 5.3 MV/m

$$\frac{1}{Q} = \frac{1}{Q_{\text{cav}}} + \frac{1}{Q_{\text{ext}}}$$

$\nearrow \sim 0$

RF cavities in linear accelerators

- Beam only passes once → **Maximize gradient**
- Many accelerating cells to best reuse RF voltage

SuperHILAC, ~70 MHz, Berkley



CLIC, 12 GHz, ~100 MV/m

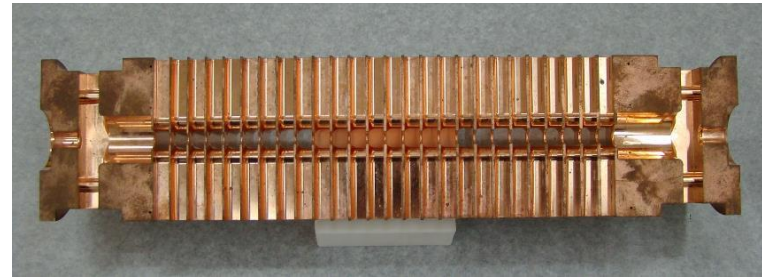

- Cavity is the **contrary to 'one size fits all'**
- **Many, many more variants**

Coupling power into a cavity

Coupling power into a cavity

- **Attack inductivity or capacitance of resonator, or combined**

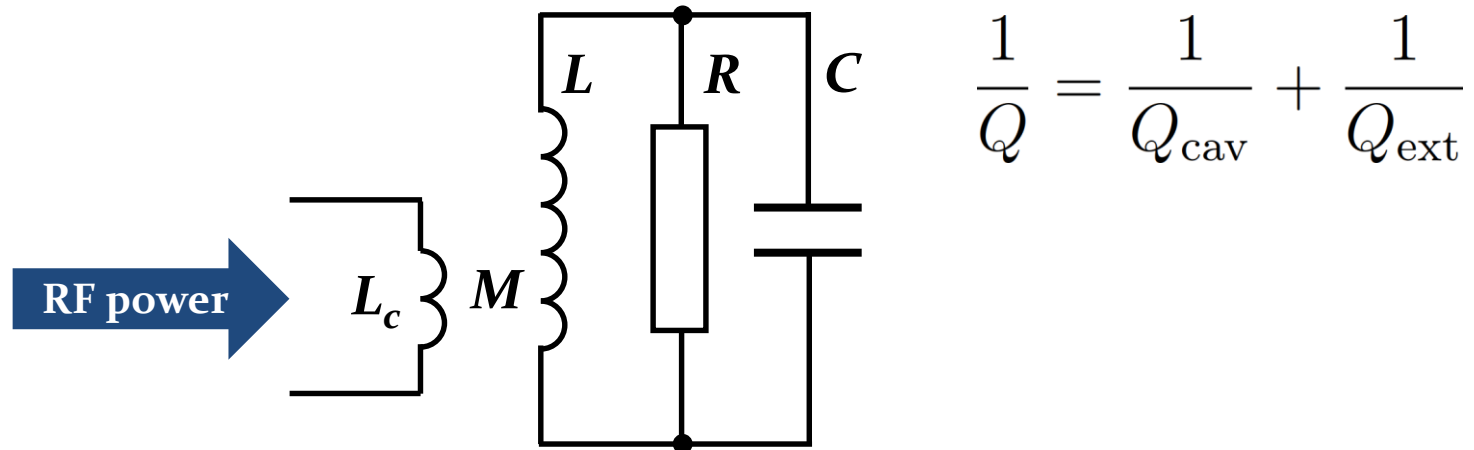

→ **Coupling loop forms transformer with resonator inductivity**

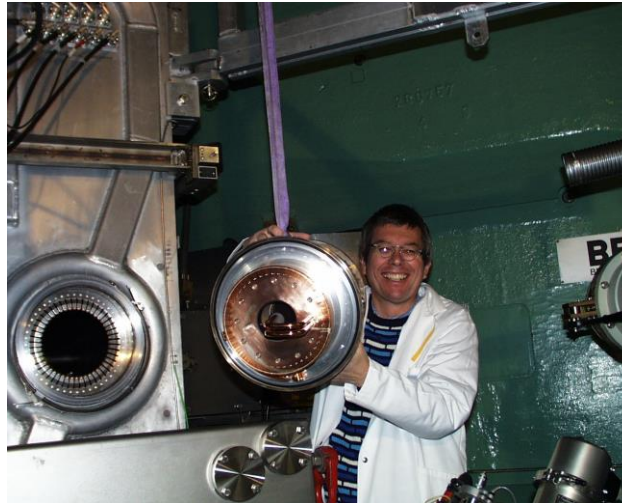

- **Main coupler
PSI cyclotron**
- **~1 MW at 50 MHz**

L. Stigelin

Coupling power into a cavity

- Attack inductivity or **capacitance** of resonator, or combined

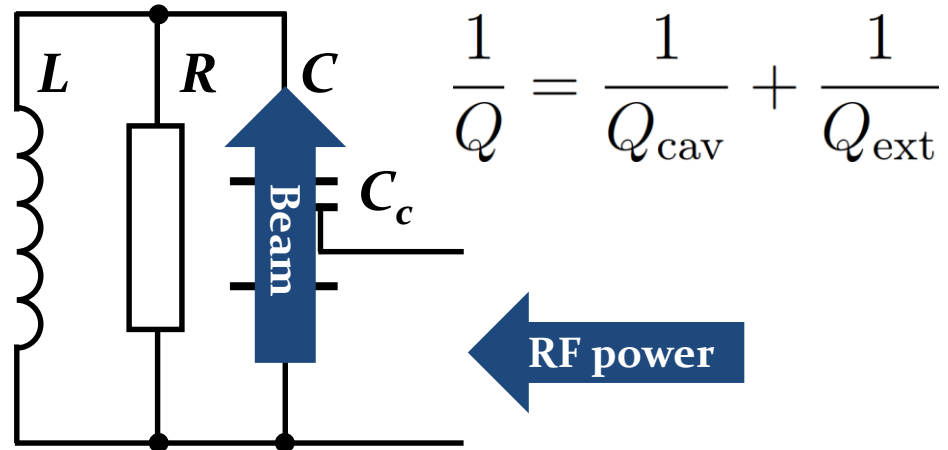

- **Capacitive divider** to gap to transform generator impedance to cavity shunt impedance
- Beam also **couples capacitively** via the gap

Coupling power into a cavity

- **Attack inductivity or capacitance of resonator, or combined**

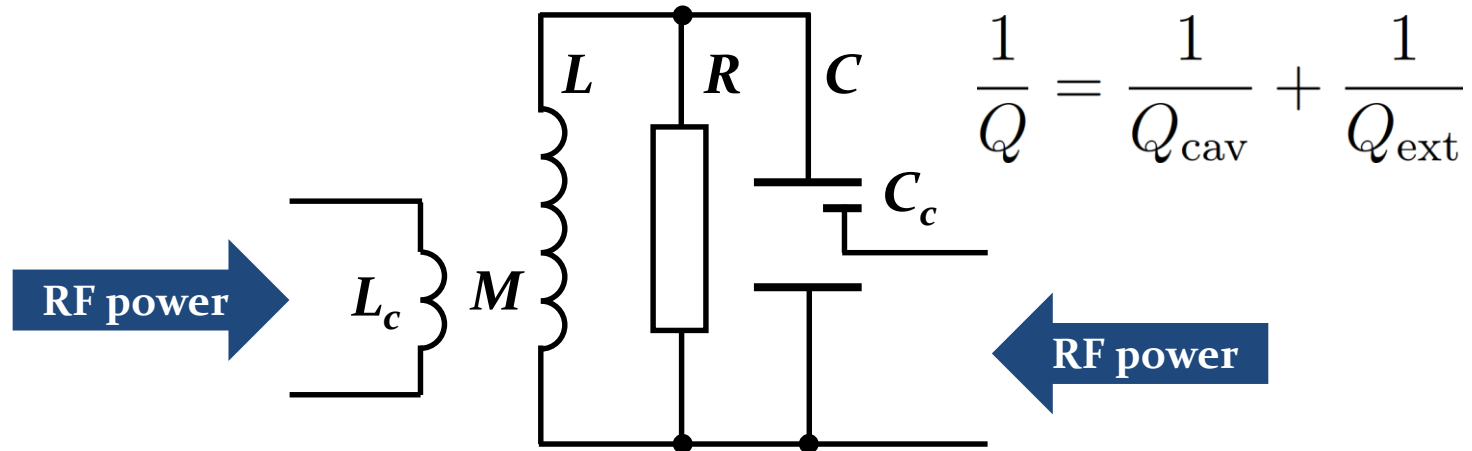

- **Combined electromagnetic coupling**
- **Antenna radiating into cavity**



Capacitive or combined coupling

- Some examples of capacitive and antenna couplers

Capacitive coupler of CERN PS 40 MHz



→ Coupler forms one **half of capacitor with the gap**

Antenna coupler of LHC cavities

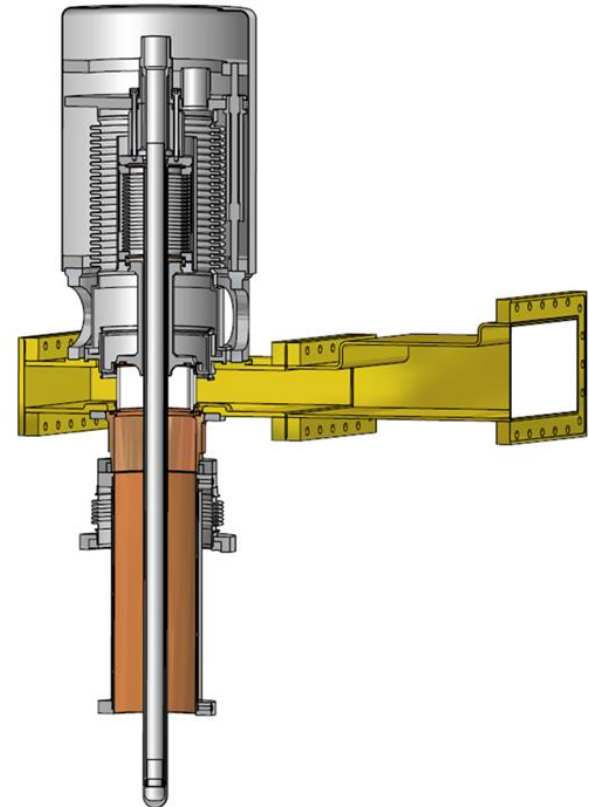

→ Coupler **antenna transmits directly into the cavity**

RF system overview

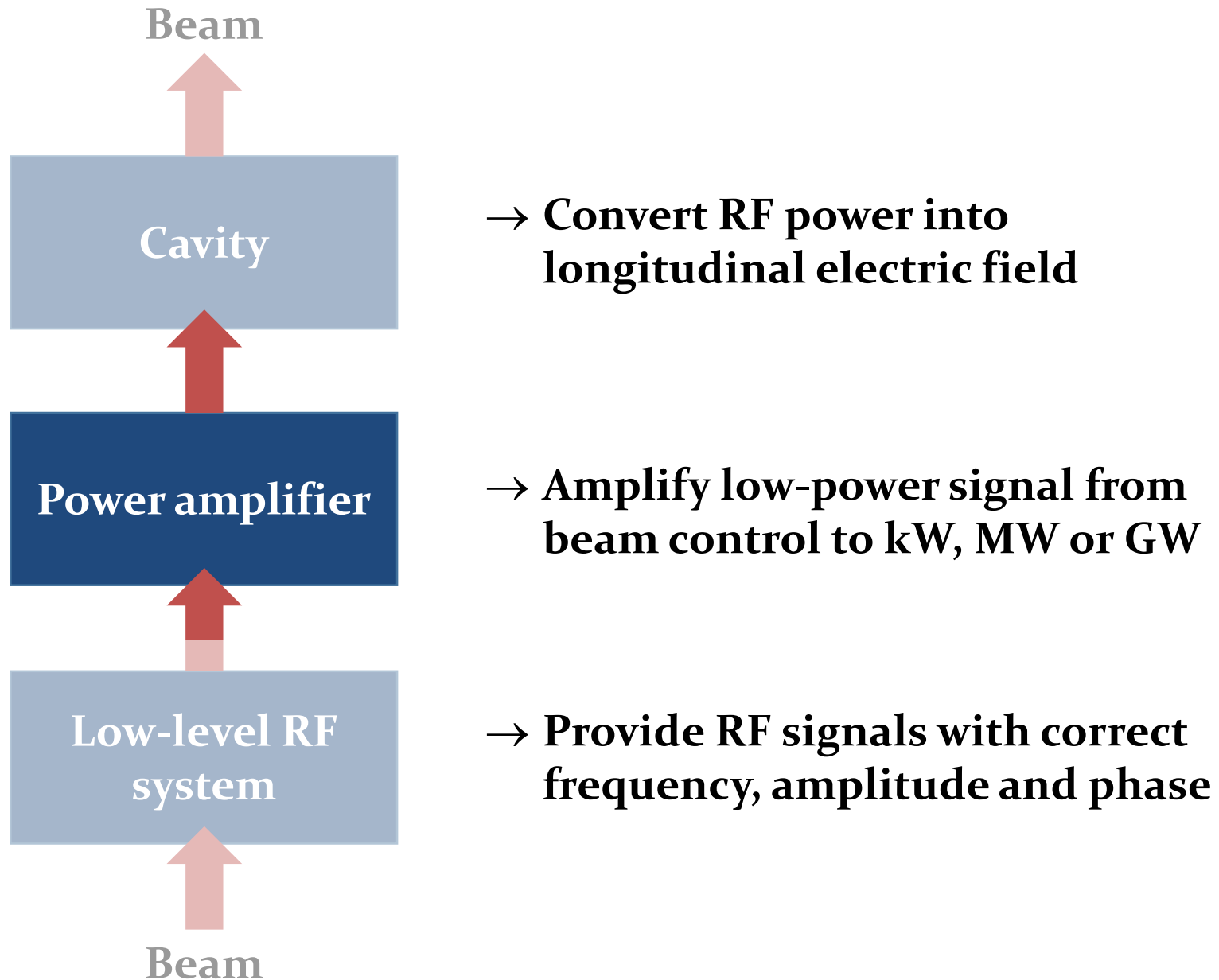

Power amplifiers

How much power is required?

1. Power to accelerate beam → Wanted
2. Compensate beam-induced voltage → Refl. P
3. Compensate electrical losses in cavity → Heat
4. Compensate electrical losses in distribution → Heat

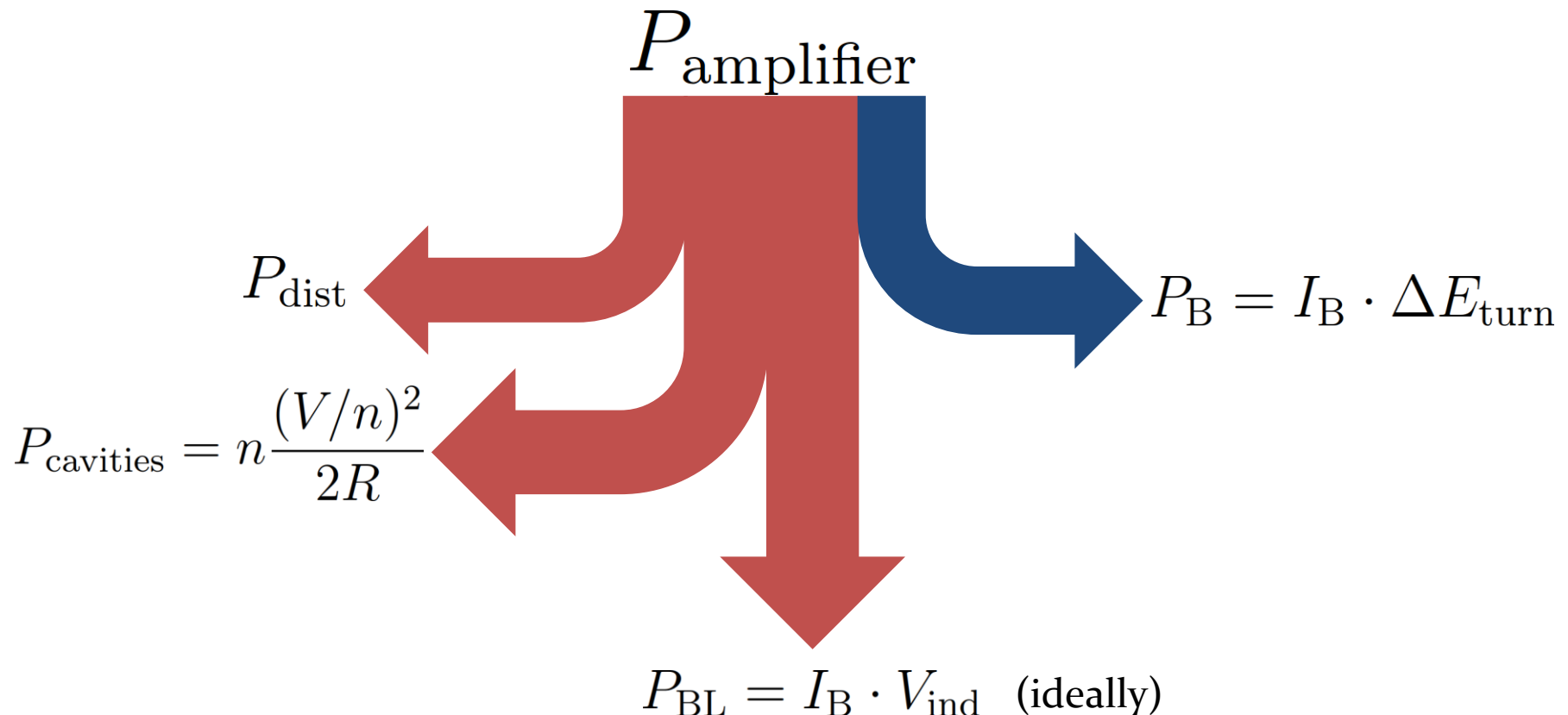

Power amplifiers

- Basically

$$P_{\text{out}} = g \cdot P_{\text{in}} \quad \text{or} \quad V_{\text{out}} = \sqrt{g} \cdot V_{\text{in}}$$

- The ideal power amplifier

- Large bandwidth: amplifies all frequencies equally
 - No saturation, infinite power
 - Zero delay
 - No added noise
 - Unconditionally stable and resistant to reverse power
 - Radiation-hard
-
- Unfortunately such a device has not been invented yet
 - Let us have a look at some real amplifiers

Basics of grid tube

- From diode to tetrode amplifier

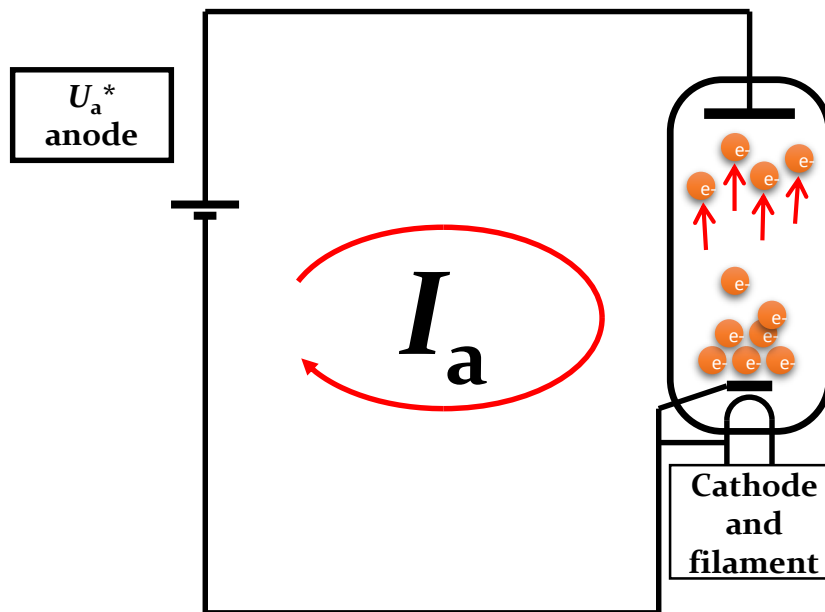

- Vacuum tube
- Heater + Cathode
- Heated cathode
 - Coated metal, carbides, borides,...
- thermionic emission
- Electron cloud
- Anode

→ Diode

*For tube amplifier designs
voltages are named U instead of V

Basics of grid tube

- From diode to tetrode amplifier

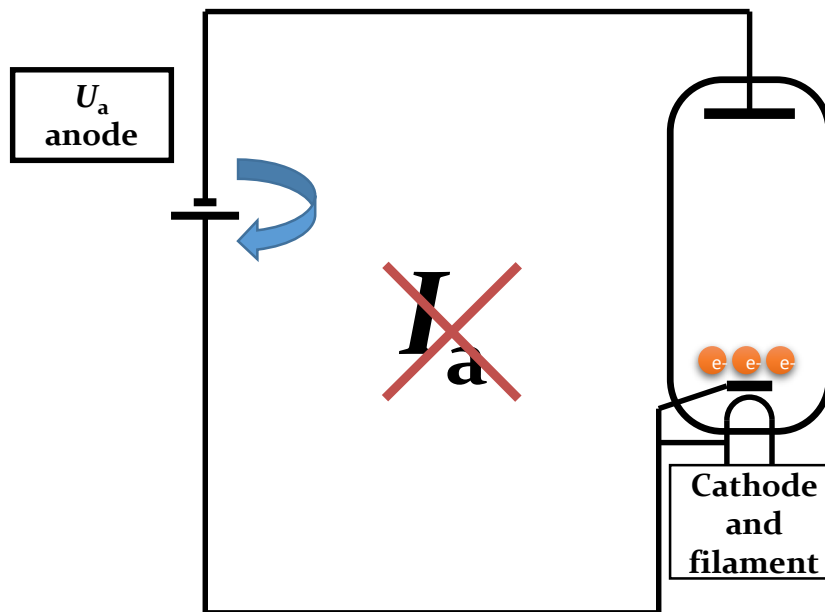

- Vacuum tube
 - Heater + Cathode
 - Heated cathode
 - Coated metal, carbides, borides,...
 - thermionic emission
 - Electron cloud
 - Anode
- Diode

Basics of grid tube

- From diode to tetrode amplifier

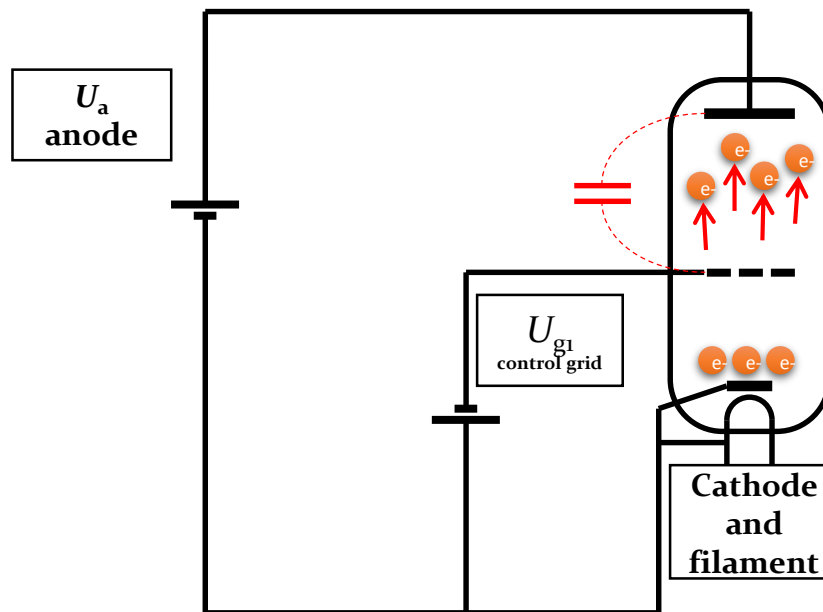

→Triode

- Modulating the grid voltage proportionally modulates the anode current
- Transconductance
 - Voltage at grid
 - Current at anode
- **Limitations**
 - Parasitic capacitor from anode to control grid (g_1)
 - Tendency to oscillate

Basics of grid tube

- From diode to tetrode amplifier

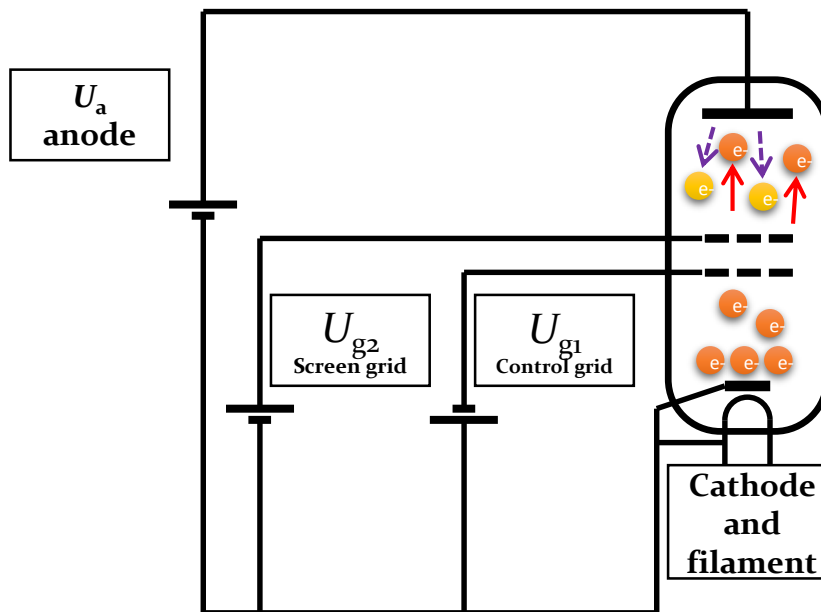

→Tetrode

- **Screen grid**
 - Positive (lower anode)
 - Decouple anode and g_1
 - Higher gain
- **Limitations**
 - Secondary electrons
 - Anode treated to reduce secondary emission

Tetrode based power amplifier

- Example of SPS 200 MHz amplifier, tetrode RS2004

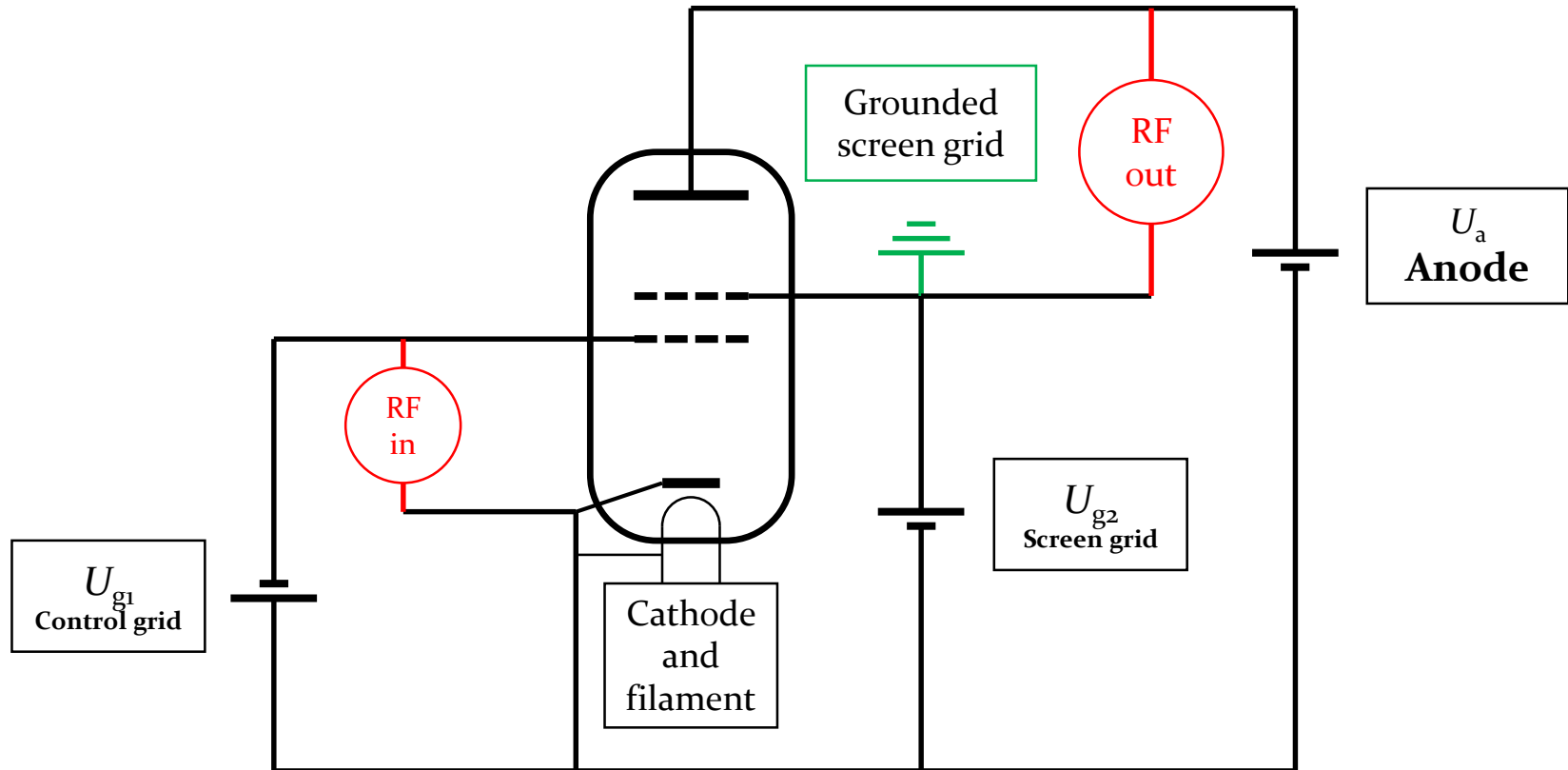

→ Very simplified block diagram

Example: Tetrode amplifier driving SPS RF

- Two transmitters, 2×1 MW at 200 MHz (almost continuous)
- Eight tetrodes per amplifier

RS2004 tetrode



Amplifier trolley



Complete transmitter



→ In operation since 1976

Tetrode amplifier driving PS RF

- Frequency range 2.8..10 MHz, ~60 kW per cavity, 11 units
- **Space constraints to have amplifier installed below cavity**

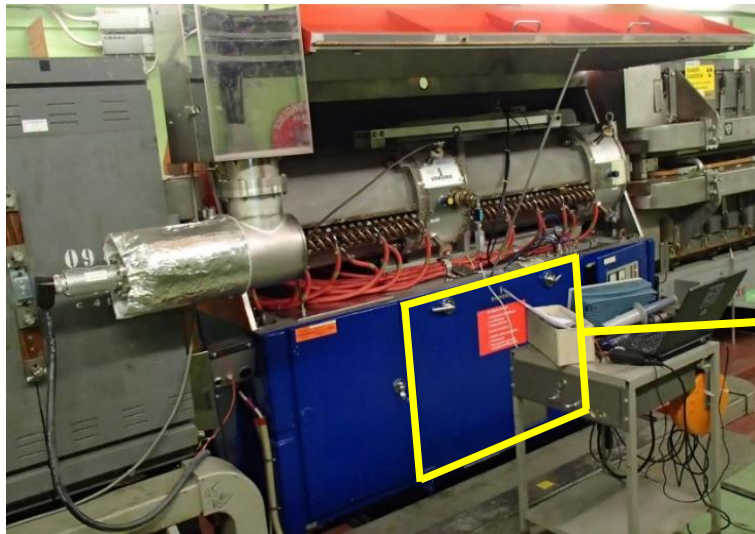

Amplifier trolley

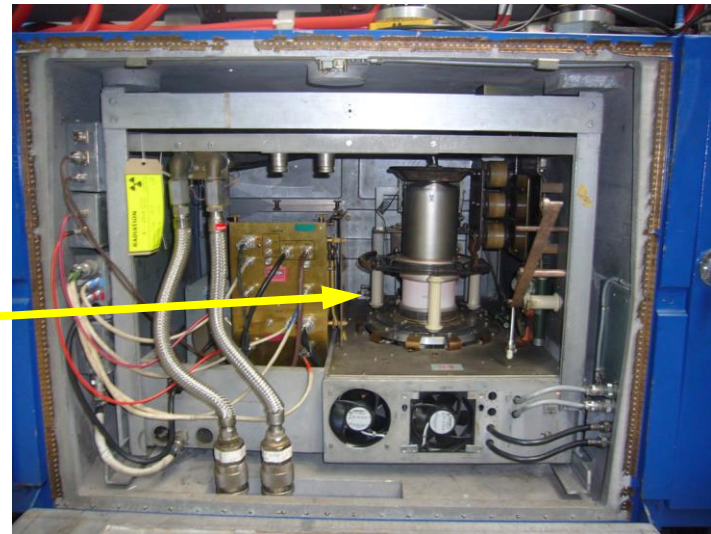

- **Tetrode is obvious choice**
 - High power in small volume
 - Operates in radioactive environment

Basics of linear beam tube

- **Klystron: a complete mini-accelerator**

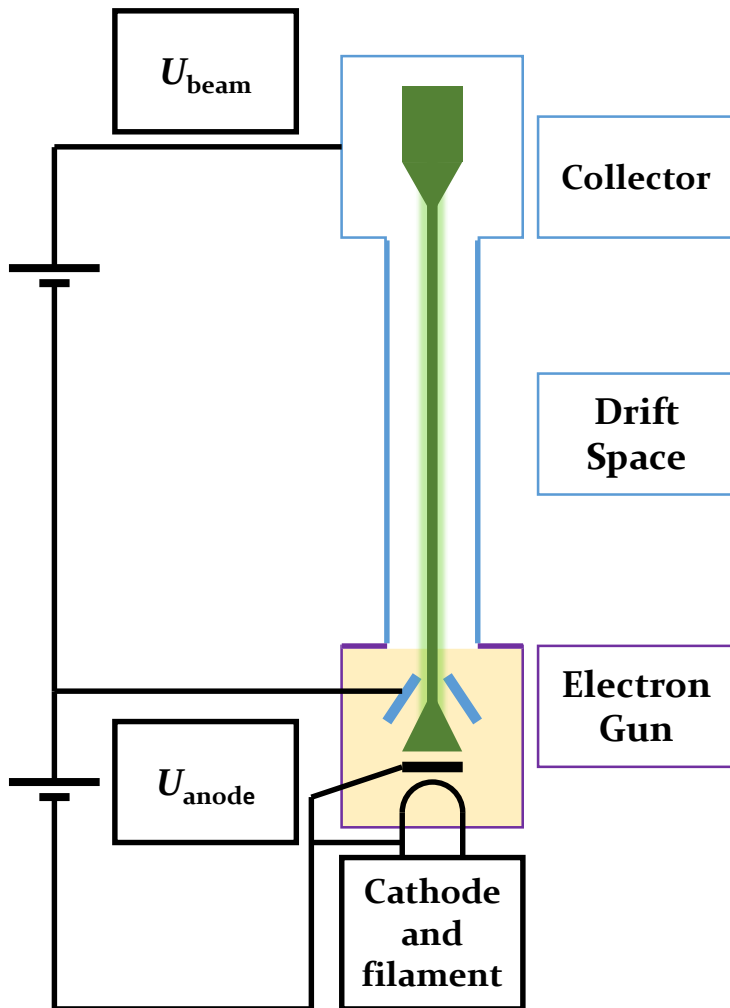

- **Klystrons velocity modulation**
 - Converts the kinetic energy into RF power
- **Vacuum tube**
- **Electron gun**
 - Thermionic cathode
 - Anode
- **Electron beam**
- **Drift space**
- **Collector**
- **e- constant speed until the collector**

Basics of linear beam tube

- **Klystron: a complete mini-accelerator**

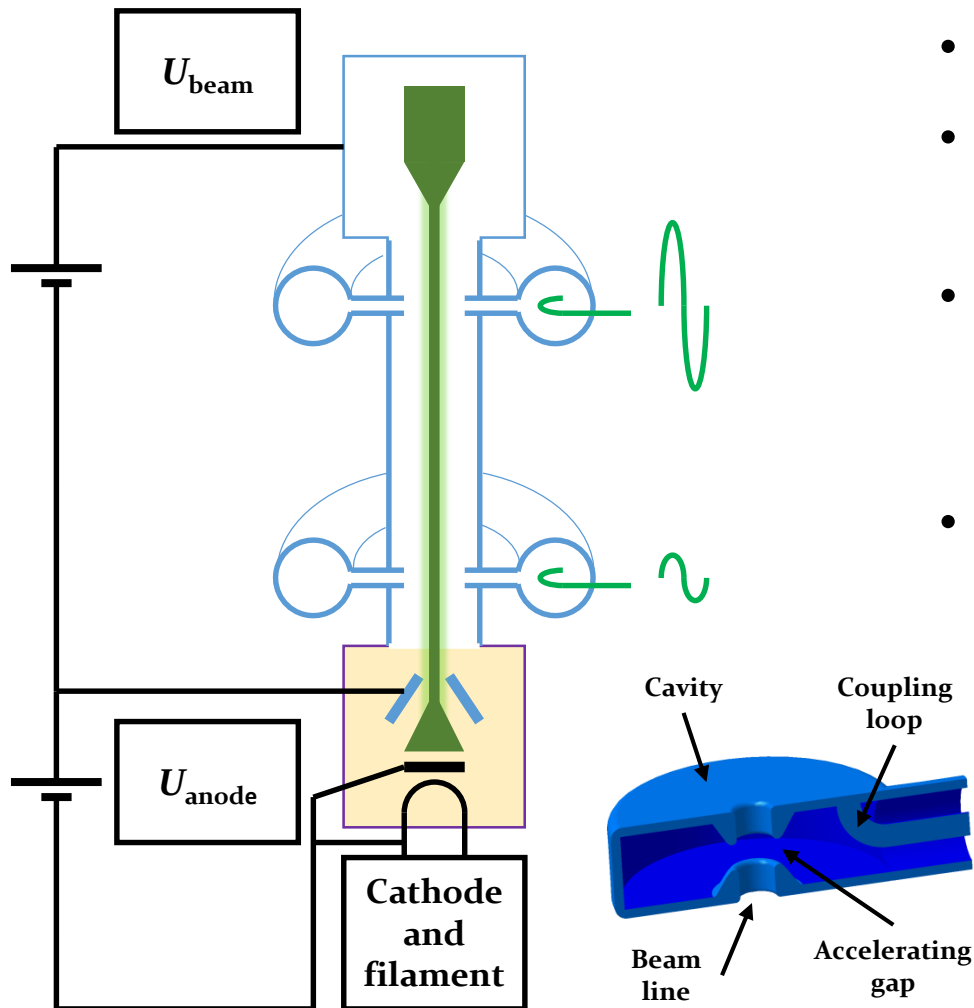

- **Cavity resonators and drift**
- **RF input cavity (Buncher)**
→ Modulates electron velocity
- **Drift space**
→ Faster electrons catch up
→ Slower electrons fall behind
- **RF output cavity (Catcher)**
 - Resonating at same frequency as input cavity
 - At place where electrons are **maximally bunched**
 - Kinetic energy converted into voltage and extracted

Basics of linear beam tube

- **Klystron: a complete mini-accelerator**

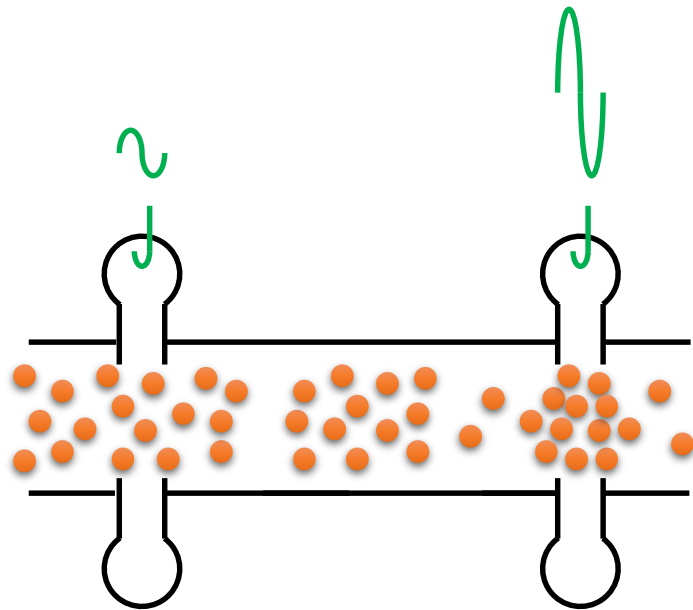

- **Cavity resonators and drift**
- **RF input cavity (Buncher)**
→ **Modulates electron velocity**
- **Drift space**
→ **Faster electrons catch up**
→ **Slower electrons fall behind**
- **RF output cavity (Catcher)**
 - **Resonating at same frequency as input cavity**
 - **At place where electrons are maximally bunched**
 - **Kinetic energy converted into voltage and extracted**

Example: Klystrons driving accelerators

- **2 × 8 cavities**, each driven by separate 400 MHz klystron, **330 kW**
→ First klystron amplifiers powering a hadron collider



E. Montesinos

- 12 GHz pulsed klystron for CLIC
→ **50 MW in 1.5 μs**



G. McMonagle

- Significantly more power was required to feed LEP (until 2000)
→ About **50 MW CW** was installed at 352 MHz

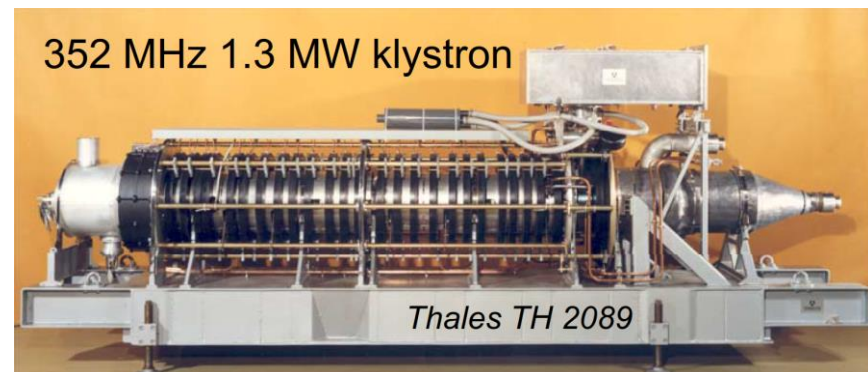

Basics of RF solid state amplifiers

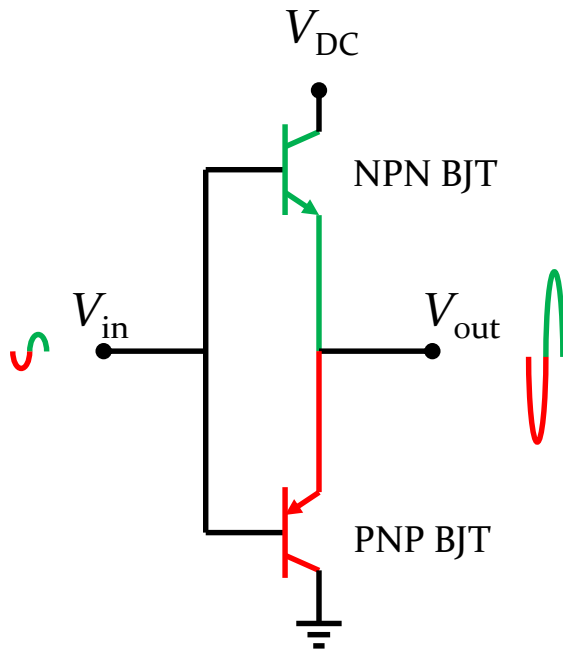

BJT: Bipolar Junction Transistor

- In a **push-pull** circuit the RF signal is applied to **two devices**
 - One of the devices is active on the positive voltage swing and off during the negative voltage swing
 - The other device works in the opposite manner so that the two devices conduct half the time
- The full RF signal is then amplified

→ Needs two different type of devices

Basics of RF solid state amplifiers

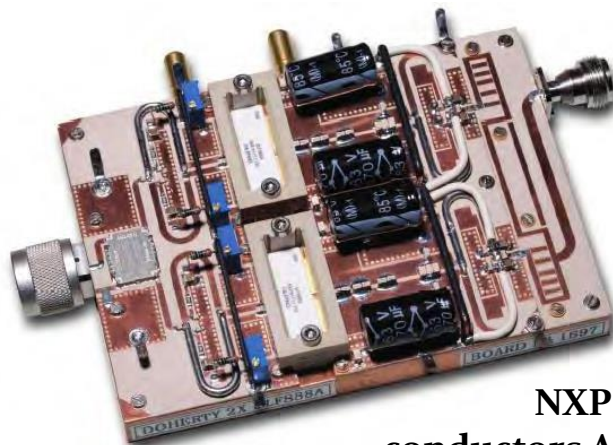
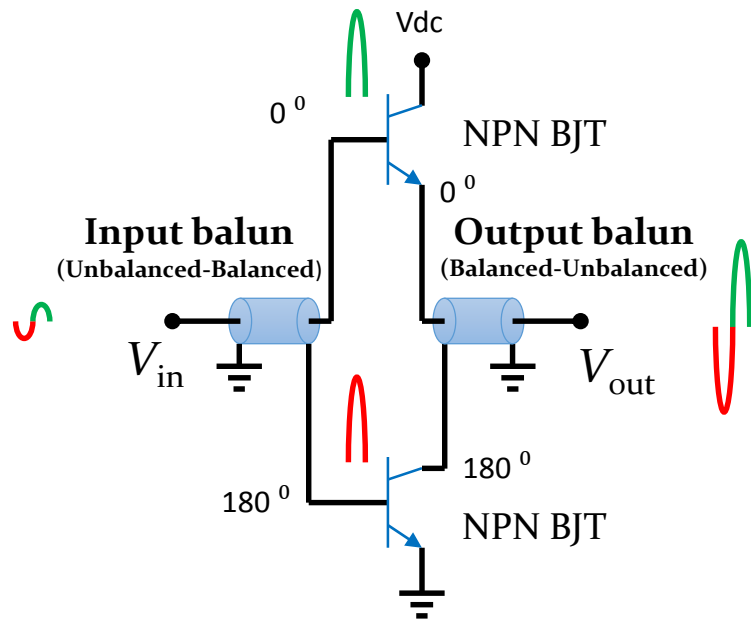

NXP Semi-
conductors AN11325
2-way Doherty amplifier with BLF888A

- Another **push-pull configuration** is to use a balun (balanced-unbalanced)
 - Power splitter, equally dividing the input power between the two transistors
 - Balun keeps one port in phase and inverts the second port in phase
 - Since the signals are out of phase only one device is On at a time
- This configuration is easier to manufacture since only one type of device is required

Example: Soleil 45 kW, 352 MHz

Electron storage ring running at 352 MHz

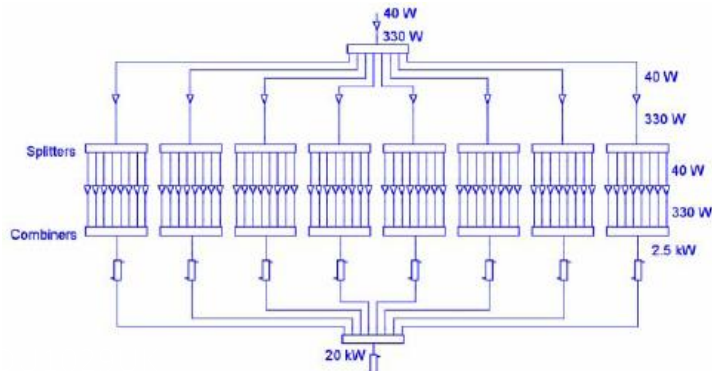

330 W amplifier module

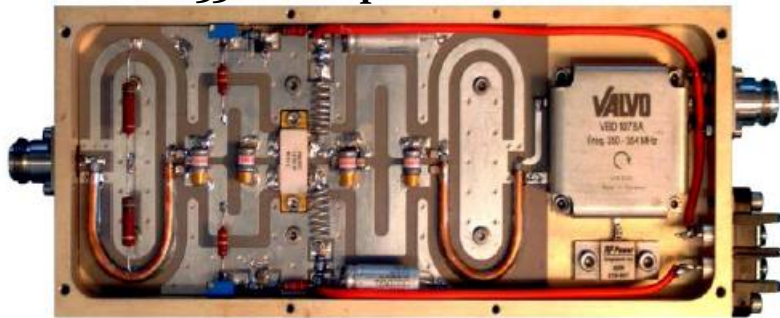

600 W, 300 V_{DC}/30 V_{DC} converter

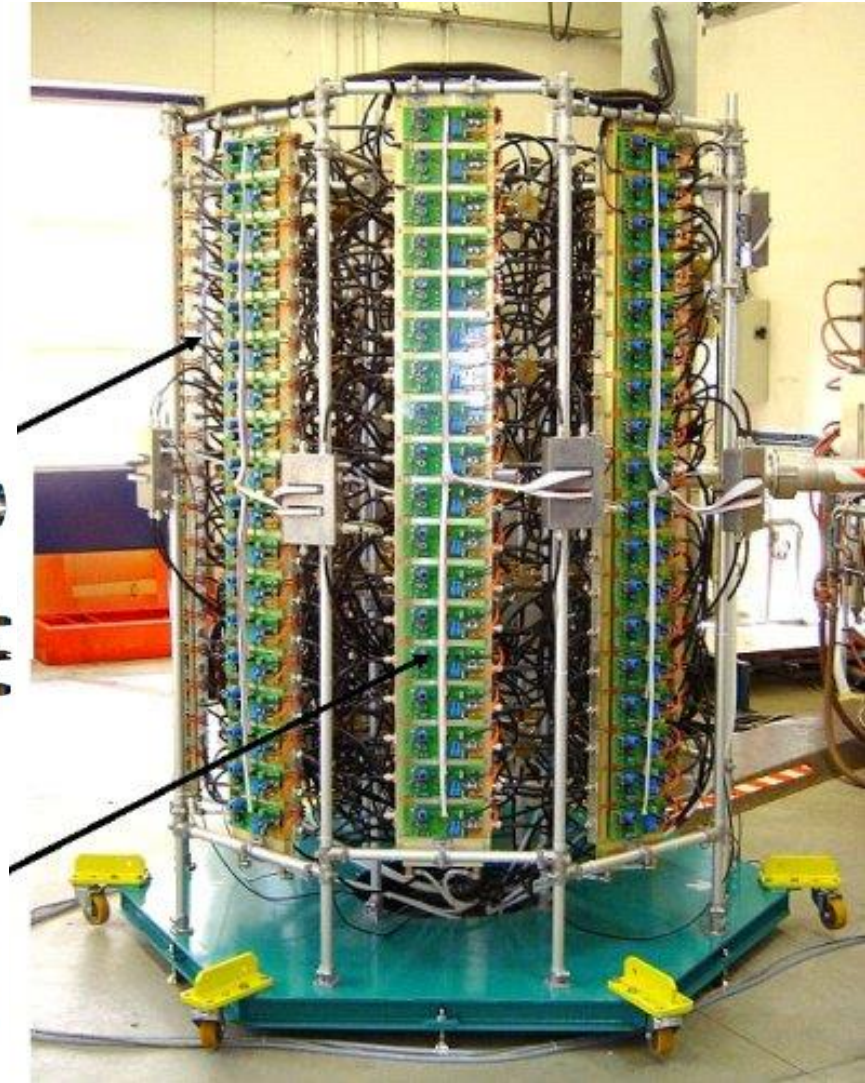

Example: Soleil 45 kW, 352 MHz

Large scale solid state amplifier installations

45 kW per tower (2004 and 2007)



150 kW per tower (2012)

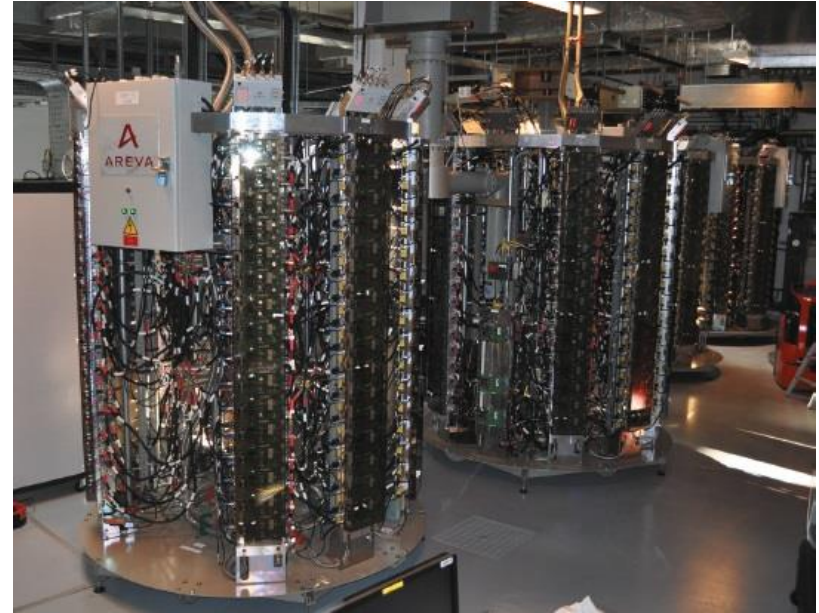

→ Requires a series of power combiners to moderate power per amplifier module to several tens of kilowatts

Example: BESSY II

500 MHz solid state amplifiers: 4×80 kW for storage ring,
 40 kW for booster synchrotron

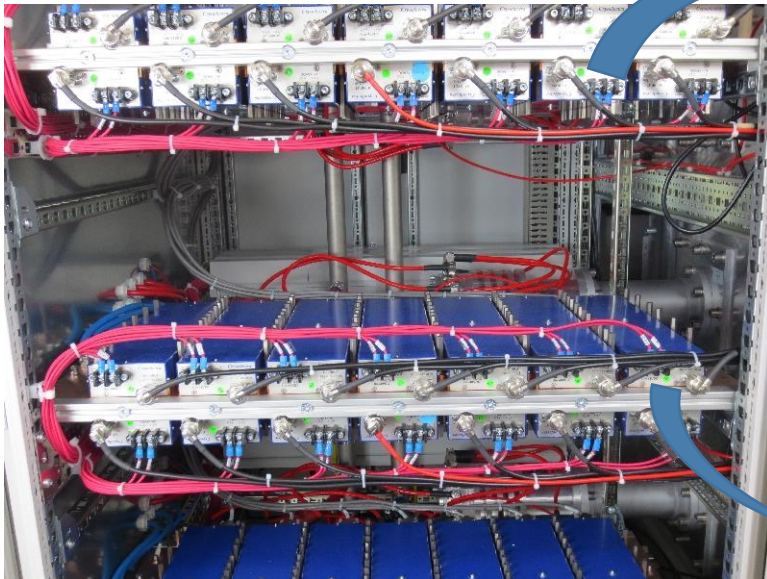

Amplifier modules



80 kW unit

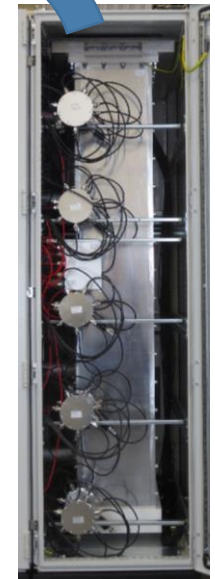

Combiner

- Power per module limited by RF transistors
- Increasing with modern semiconductor devices

Example: SPS

200 MHz solid state amplifiers: 2×1.6 MW peak power,
 2×16 towers per amplifier

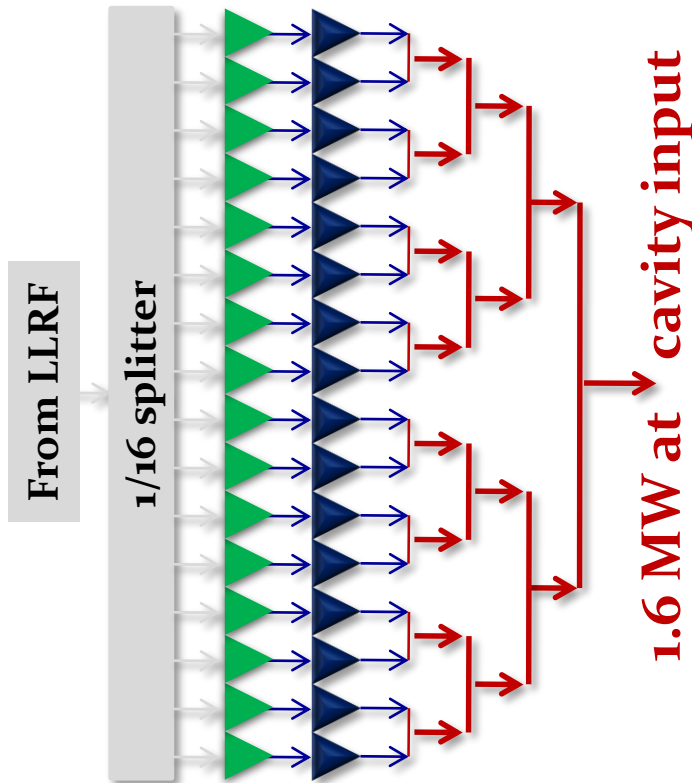

- 80 modules per tower, 1280 modules with **5120 transistors per amplifier**
- Presently the **largest RF installation** in a particle accelerator

RF power amplifier

Power capability of commercially available amplifier types

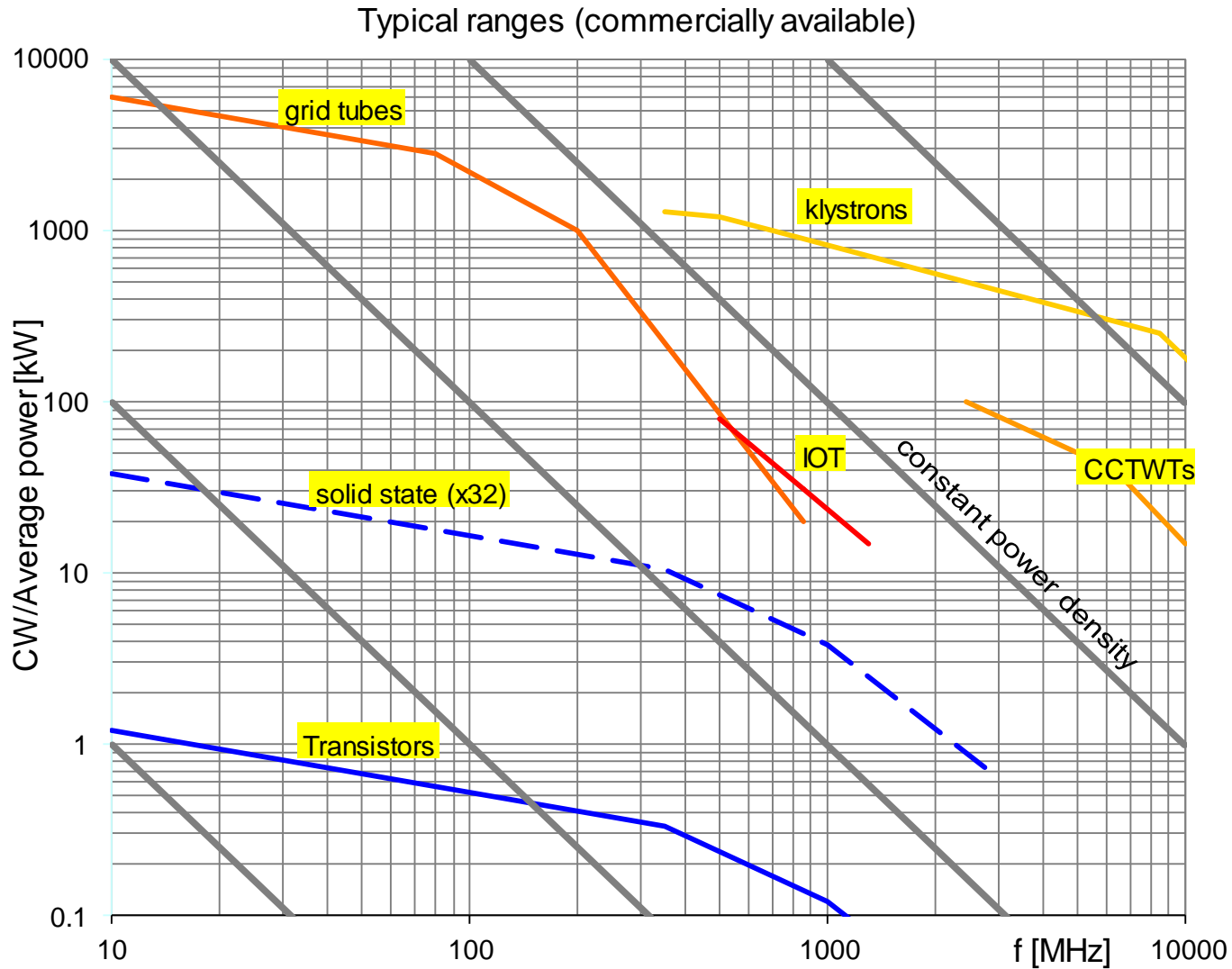

How to choose the right RF amplifier?

Prefer tube amplifier, when	Prefer solid-state amplifier, when
<ul style="list-style-type: none"> • Amplifier must be installed in the accelerator tunnel • Expecting important spikes from beam induced voltage • Large output power of a single device is required, without combiners • Not much space is available • High peak power in pulsed mode • Amplifier must be compact and/or close to cavity 	<ul style="list-style-type: none"> • Amplifier can be located in non-radioactive environment • Circulator can be installed to protect the amplifier • Delay due to unavoidable combiner stages is little issue • Sufficient space can be made available • Continuous operation • Amplifier can be separate from the cavity

→ Mostly no hard criteria → decide on case by case basis

Summary

- **RF system parameters**
 - **Choose frequency and voltage wisely**
- **Parameters of RF cavities**
 - **R , R/Q**
 - **No 'one-size fits' all**
- **Power amplifier**
 - **Ideal amplifier does not (yet) exist**
 - **Tube or solid-state based**
- **Feedbacks and longitudinal beam control**
 - **Make the beam feel comfortable in bucket**
 - **Beam phase, radial and synchronization loops**

RF Systems II



H. Damerou
CERN



Basic CAS Extension

01 July 2021

Copyright statement and speaker's release for video publishing

The author consents to the photographic, audio and video recording of this lecture at the CERN Accelerator School. The term “lecture” includes any material incorporated therein including but not limited to text, images and references.

The author hereby grants CERN a royalty-free license to use his image and name as well as the recordings mentioned above, in order to broadcast them online to all registered students and to post them without any further processing on the CAS website.

The author hereby confirms that the content of the lecture does not infringe the copyright, intellectual property or privacy rights of any third party. The author has cited and credited any third-party contribution in accordance with applicable professional standards and legislation in matters of attribution.

Outline

- Introduction
- Choice of parameters
 - Frequency and voltage
- RF cavity parameters
 - Shunt impedance, beam loading, power coupling
- **Power amplifiers**
 - Tube or solid state
 - Local feedbacks
- **Longitudinal beam control system**
 - Building blocks: RF source and receiver
 - Phase, radial and synchronization loops
- **Summary**

RF system overview

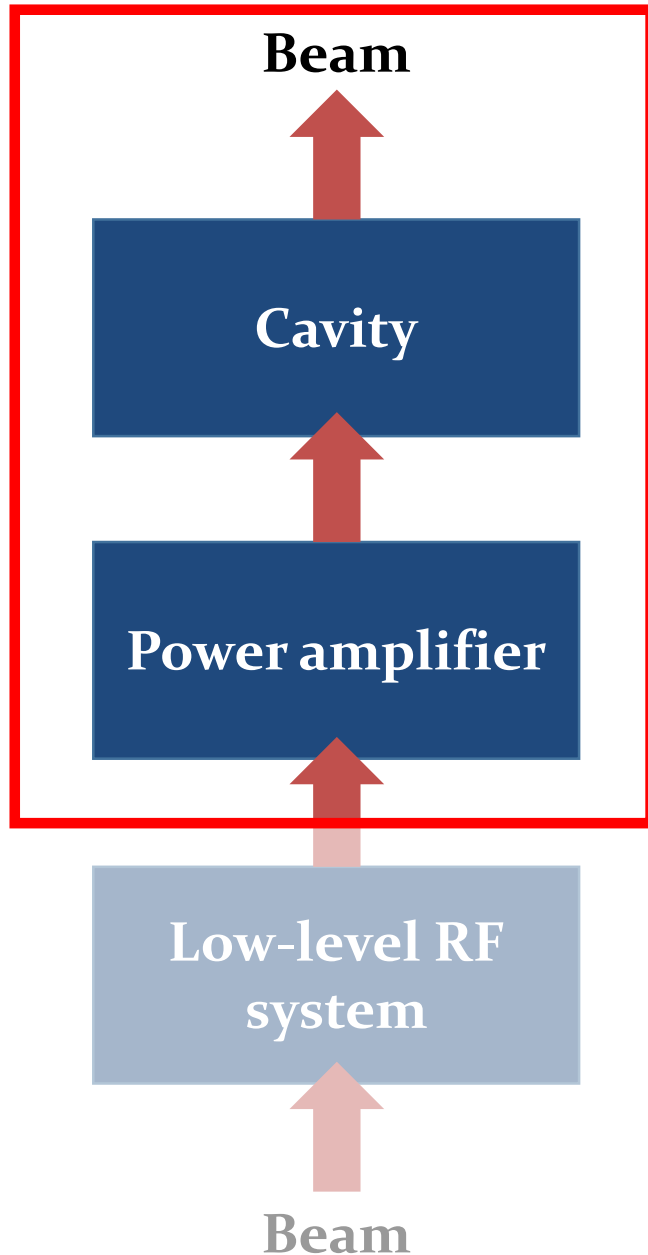

→ Convert RF power into longitudinal electric field

→ Amplify low-power signal from beam control to kW, MW or GW

→ Provide RF signals with correct frequency, amplitude and phase

Local feedbacks

Reduction of cavity impedance

- Energy transfer from cavity to beam, but **from beam to cavity**
- Both, RF generator and **beam can induced voltage** in cavity

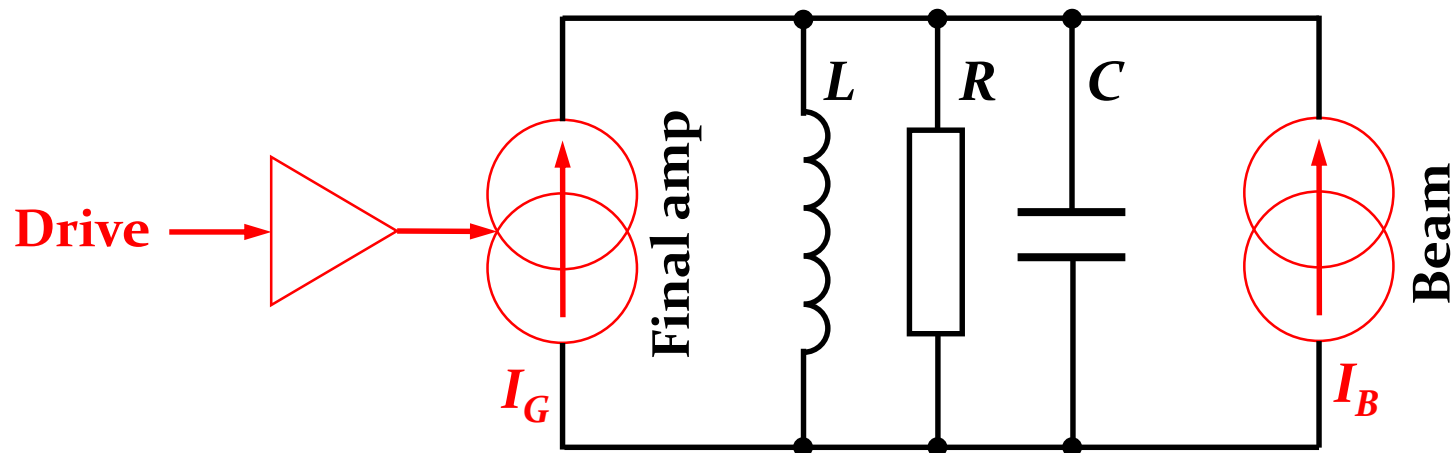

1. Reduce beam induced voltage by reducing R , **but not efficient**
→ Obviously needs more power → \$\$\$
2. Feedback to decrease the apparent impedance for the beam
→ Use amplifier to counteract beam induced voltage

Reduction of cavity impedance

- Energy transfer from cavity to beam, but **from beam to cavity**
- Both, RF generator and **beam can induced voltage** in cavity

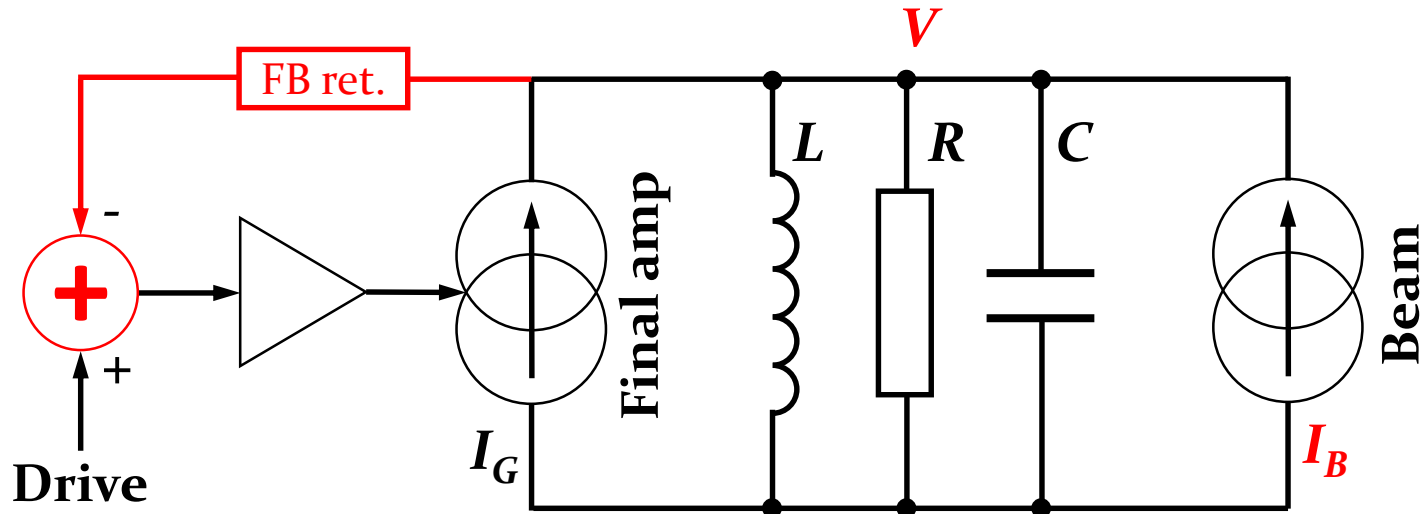

1. **Compare** drive signal (no beam) with gap (beam and generator)
2. **Amplify** inverted difference

$$Z_{\text{eq}}(\omega) = \frac{dV}{dI_B} = \frac{Z(\omega)}{1 + g_{\text{OL}}}$$

Example: 10 MHz RF system in CERN PS

Transfer function with and without feedback

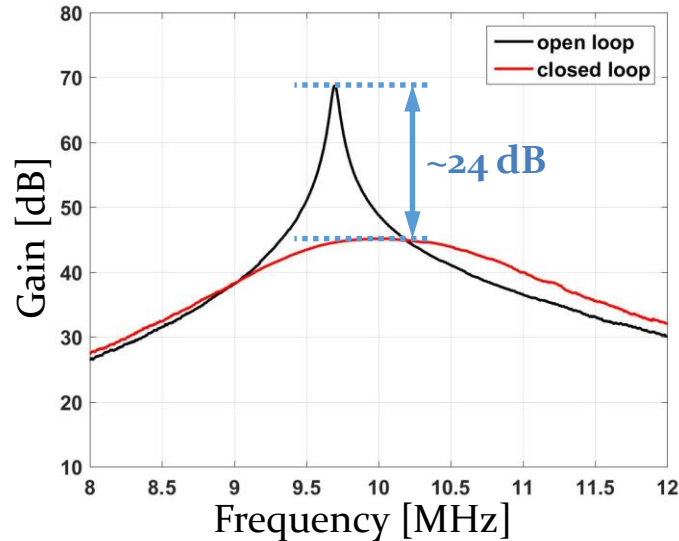

- Feedback gain of 24 dB
- Equivalent impedance, $Z_{eq}(\omega)$ reduced
- Impedance for amplifier remains unchanged, $Z(\omega)$



Why not further reduction with more gain?

- Subtraction of gap voltage and drive signal imperfect due to
 1. Delay of cables and amplifier
 2. Parasitic resonances of amplifier and cavity system

Bandwidth \uparrow \Leftrightarrow Achievable gain \downarrow

Example: 10 MHz RF system in CERN PS

- 10 + 1 ferrite loaded cavities, tunable from 2.8...10 MHz

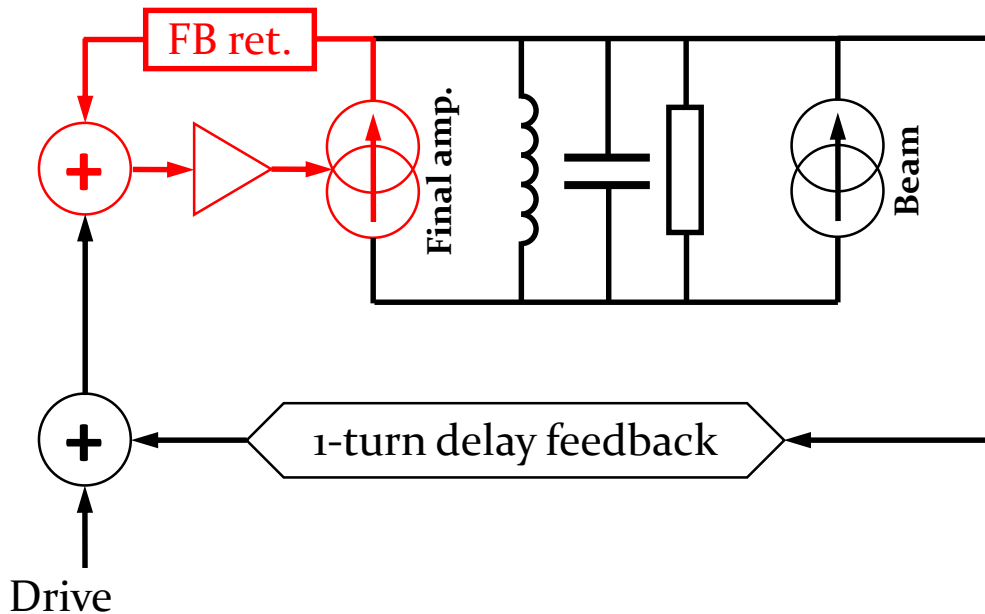
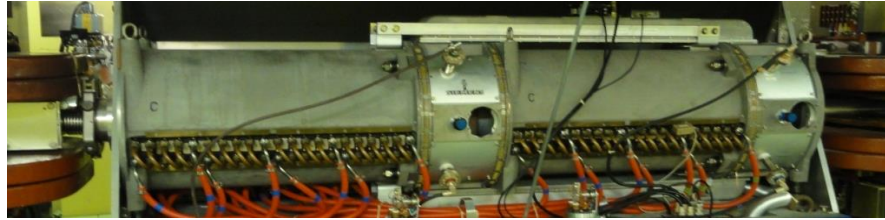

- Fast wide-band feedback
around amplifier (internal)
→ Gain limited by delay

Example: RF feedback with 1-turn delay

- 10 + 1 ferrite loaded cavities, tunable from 2.8...10 MHz

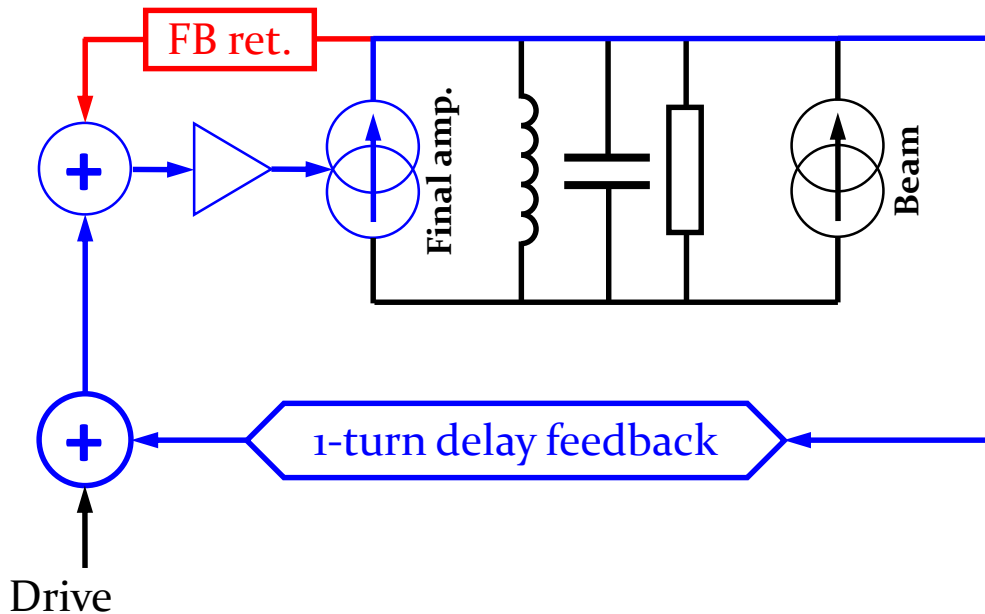
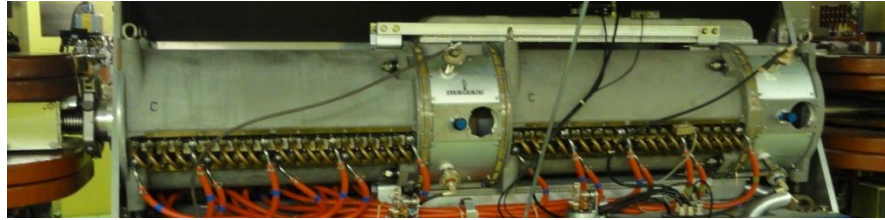

- Fast wide-band feedback
around amplifier (internal)
→ Gain limited by delay

- 1-turn delay feedback
→ High gain at $n \times f_{rev}$

Example: RF feedback with 1-turn delay

→ Reduce cavity impedance beyond stability limit of wide-band FB

Open/closed loop transfer functions

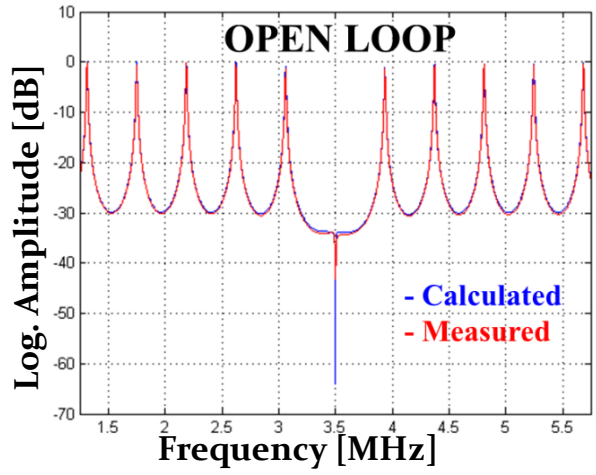

Spectrum at cavity gap return

Feedback off

Feedback on

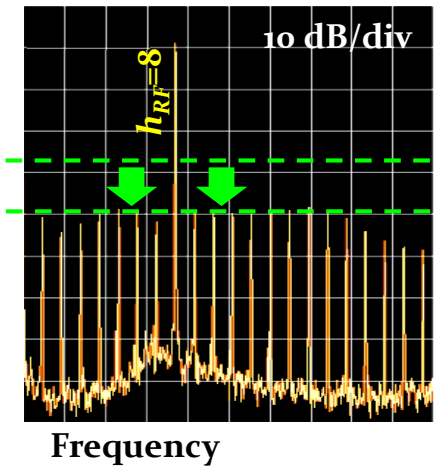
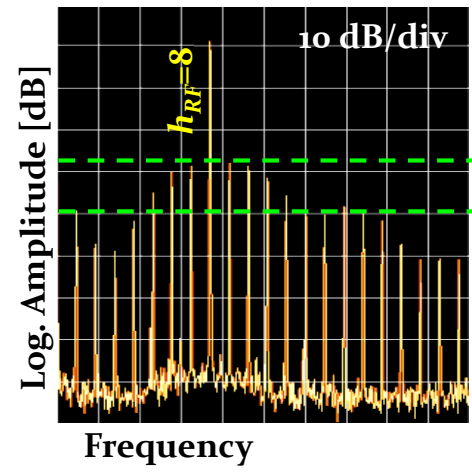

D. Perrelet

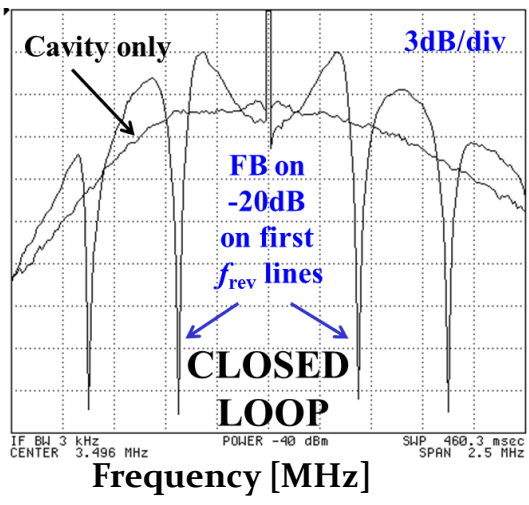

→ Important additional impedance reduction

→ Clever usage of beam periodicity in circular accelerator

RF system overview

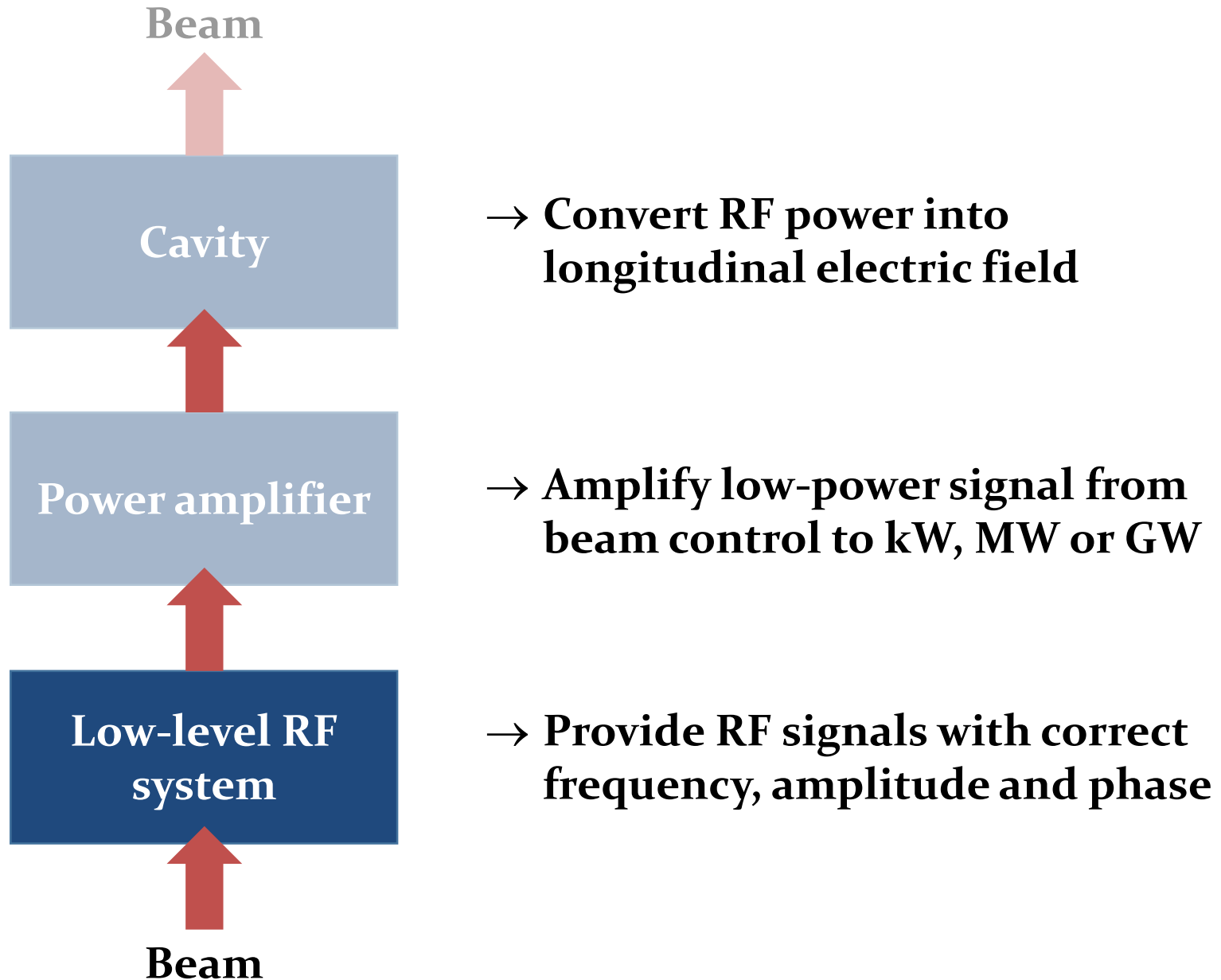

Global feedbacks

Low-level RF beam control

Longitudinal beam control

- **Local** feedbacks → Act on individual RF stations
- **Global** feedbacks → Act on all RF stations simultaneously

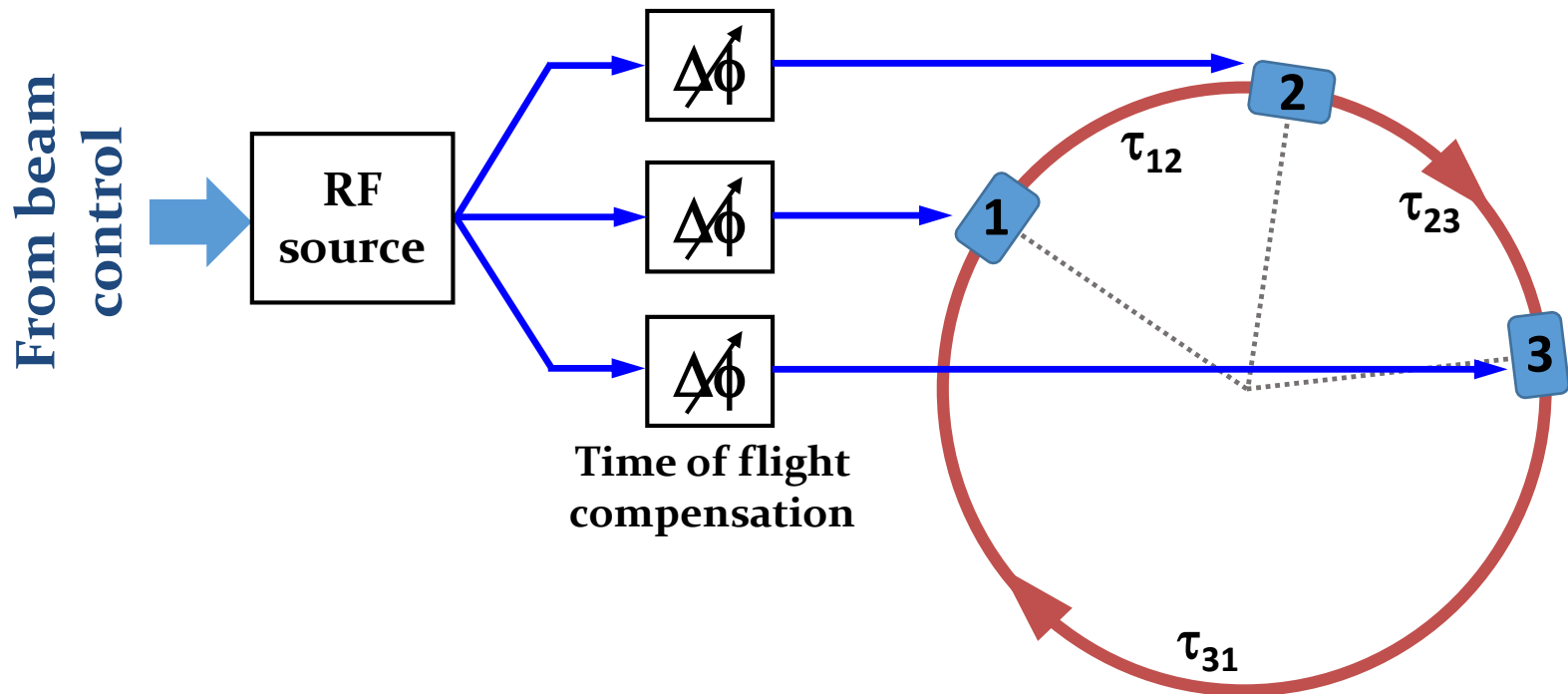

- RF distribution to compensate time of flight between stations
- Beam control drives all stations **like a single one**

Basic building blocks

Measure phase differences

- Two signals at different frequencies ω_1 and ω_2

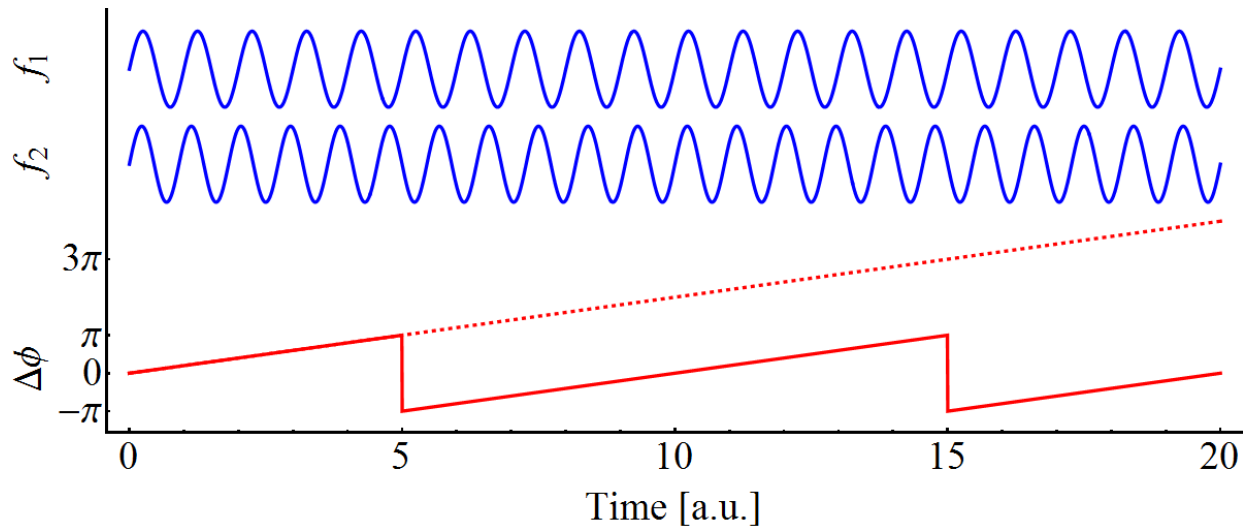

- Phase difference, $\Delta\phi$, between both signals changes linearly
- Ambiguity to distinguish between $\Delta\phi = -\pi, \pi, -3\pi, 3\pi, \dots$
- Saw-tooth in phase means constant frequency difference

→ Equivalence of frequency and phase

$$\omega = \frac{d\phi}{dt} \quad \leftrightarrow \quad \phi = \int \omega dt$$

Mixer or multiplier

- **Example: analogue 4 quadrant multiplier and low pass filter**

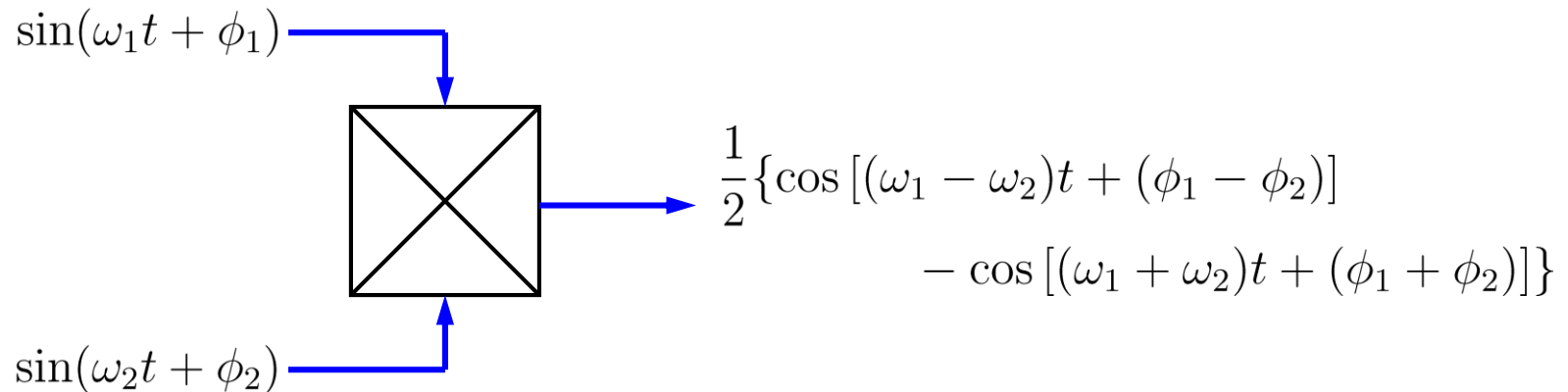

- **Signals:**

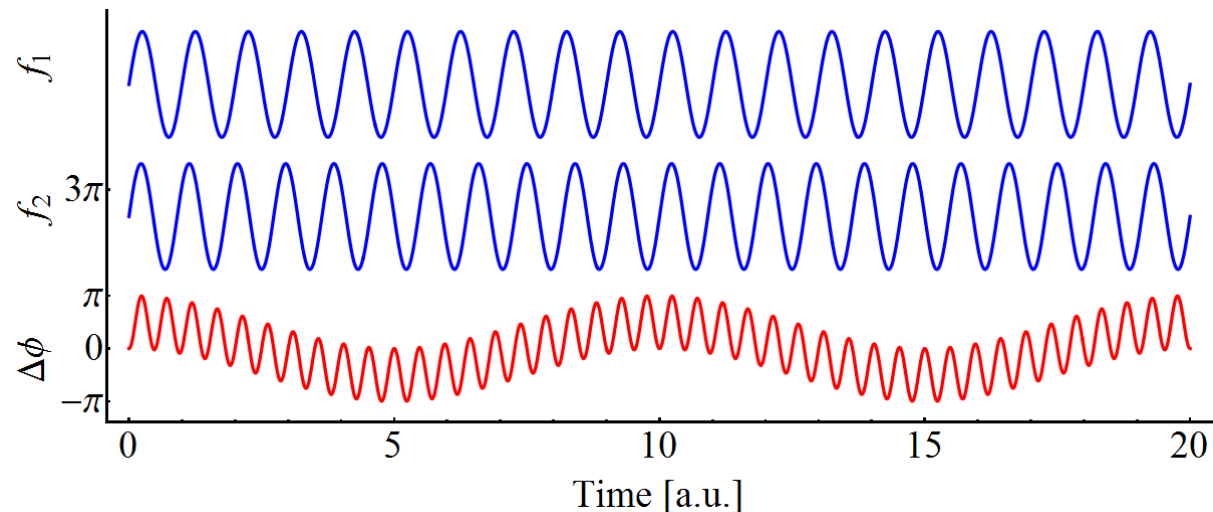

Mixer or multiplier

- **Example: analogue 4 quadrant multiplier and low pass filter**

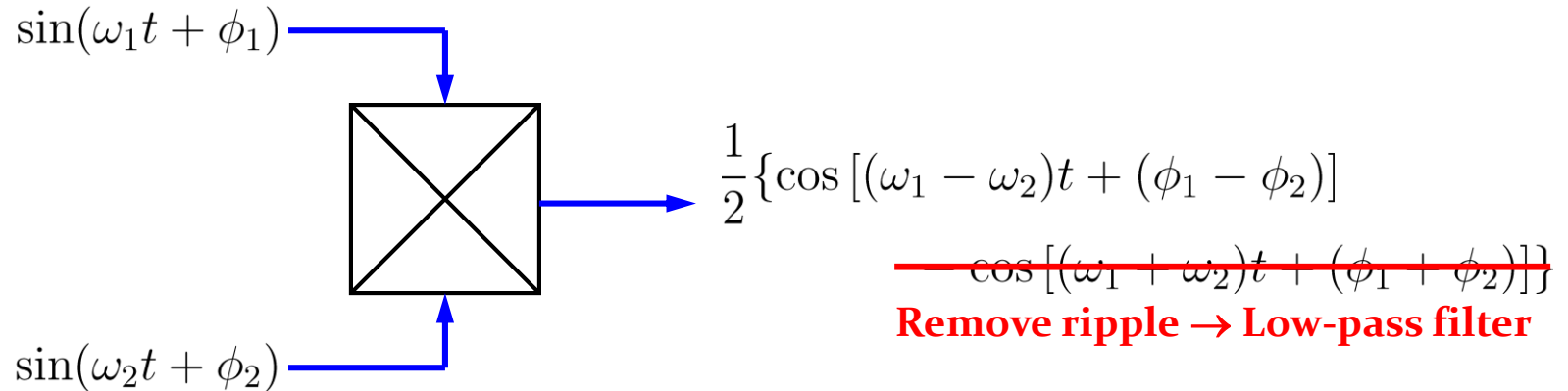

- **Signals:**

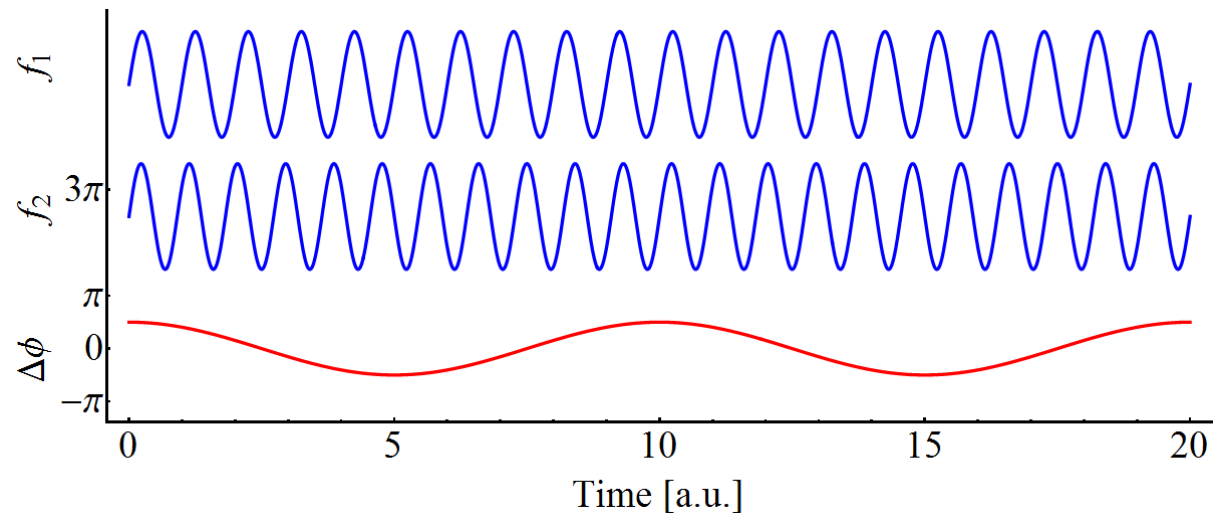

How to detect phase differences?

- **Example: analogue 4 quadrant multiplier and low pass filter**

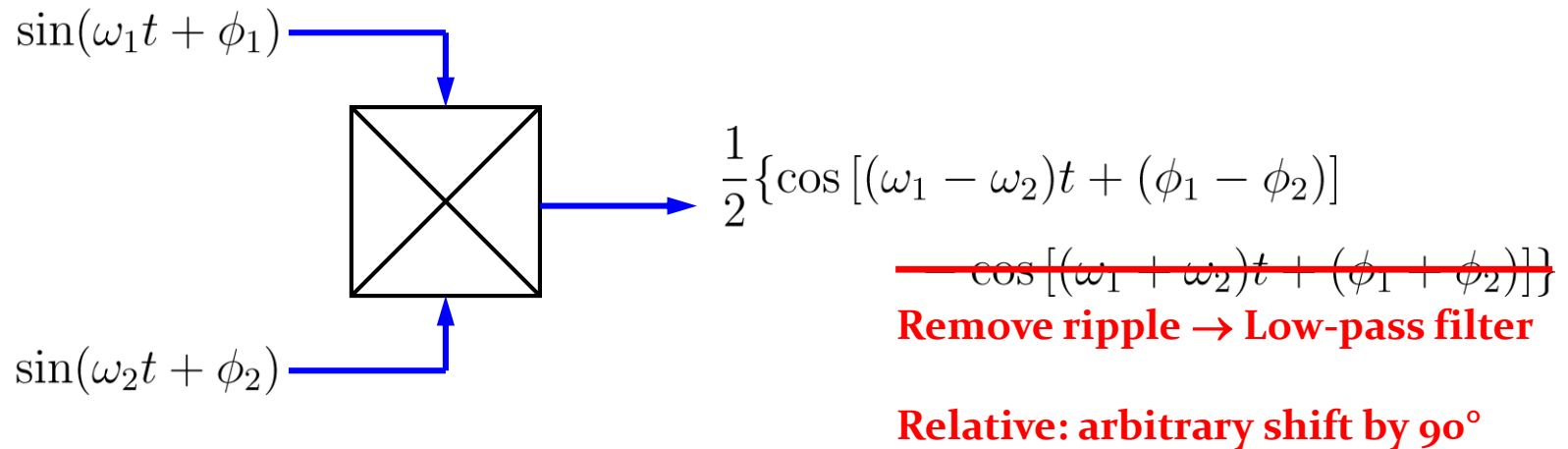

- **Signals:**

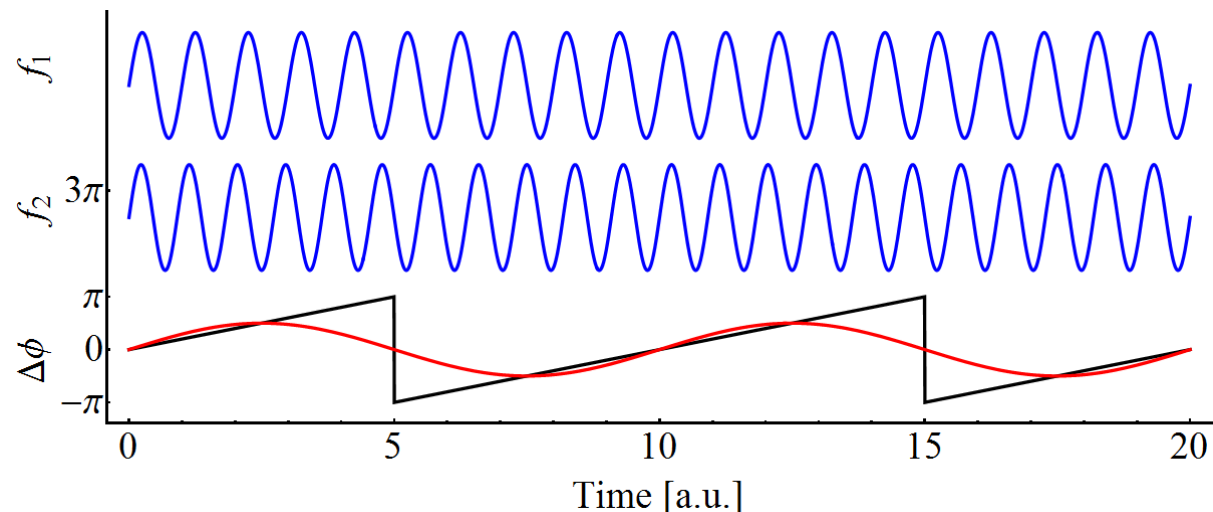

- **Phase discriminator in approximately $\pm 90^\circ$ range**

RF sources

RF sources

What finally generates the RF signal to power amplifier and cavity?

→ Need an RF source!



- **Electron accelerators**

- Off-the-shelf high-performance laboratory generators as reference: **BESSY SR, CERN CTF₃**
- Dedicated commercial fixed-frequency sources with low phase noise: **free electron lasers, CERN AWAKE**

- **Proton accelerators**

- Special sweeping RF sources, controlled by beam-based loops: **mostly in-house developments**

Noisy RF signals

- Degradation of signal quality due to noise
 - Amplitude and/or phase jitter
- What is the difference between a coherent signal and noise?

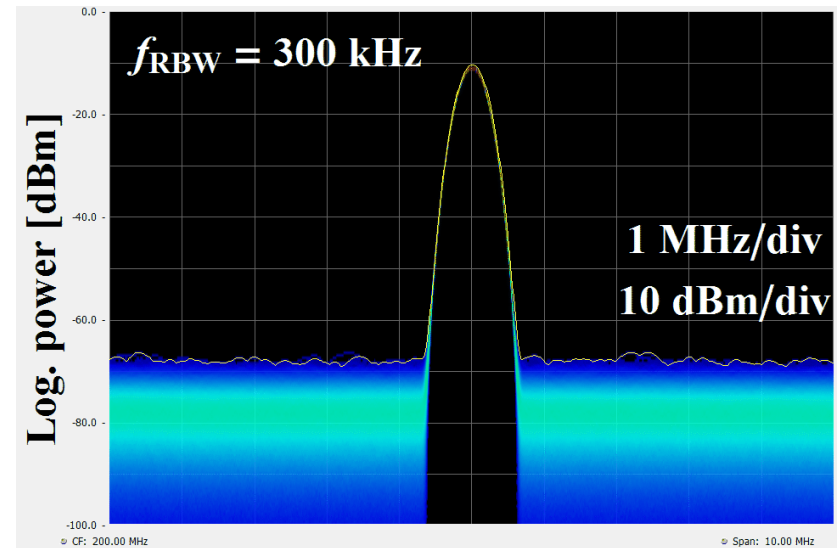
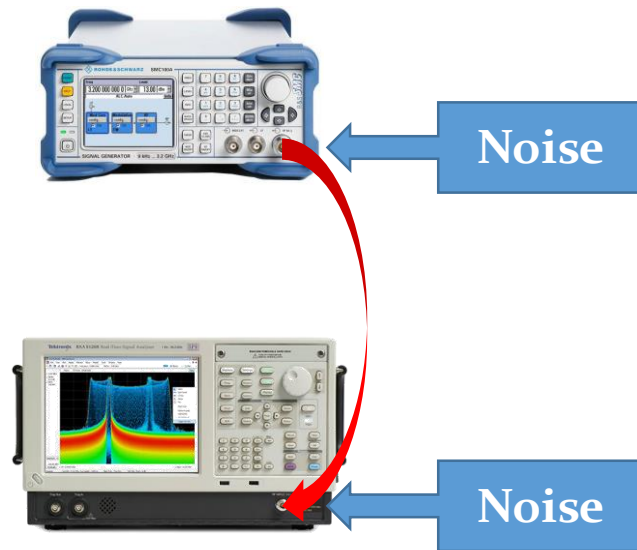

- Amplitude of **coherent**, quasi **monochromatic** signal (at 200 MHz) is **independent of observation bandwidth**
- Incoherent **noise power** (dominated by spectrum analyzer front-end amplifier/mixer) is **proportional to bandwidth**
- Thermal noise power $\frac{P}{\Delta f} = k_B T = 1.38 \cdot 10^{-23} \text{ J/K} \cdot 296 \text{ K} \simeq -174 \text{ dBm/Hz}$

Analysis of phase noise

- Compare noise power with carrier power as reference

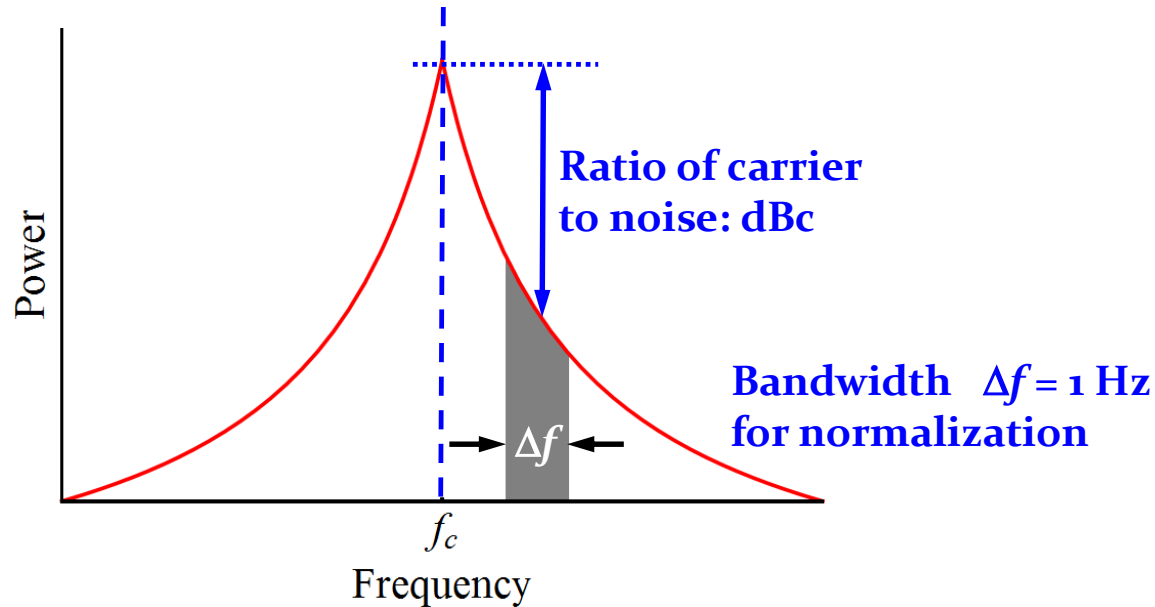

- **Noise power density** $\mathcal{L}(f) = \frac{\text{Power density}}{\text{Carrier power}} \left[\frac{\text{dBc}}{\text{Hz}} \right] = \frac{1}{2} S_\phi(f)$

→ Its integral is the phase jitter and using $\Delta t = \frac{\Delta\phi}{2\pi f_c}$

the jitter in time becomes

$$\Delta t_{\text{rms}} = \frac{1}{2\pi f_c} \sqrt{\int_{f_1}^{f_2} S_\phi(f) df}$$

Typical phase noise plots

- Measure phase noise of a synthesized lab generator

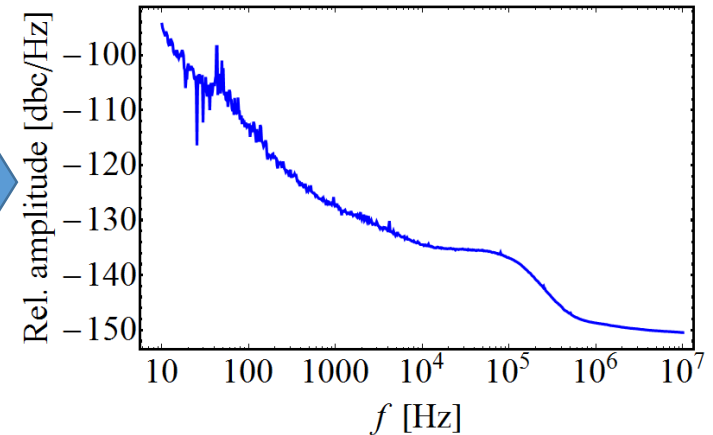
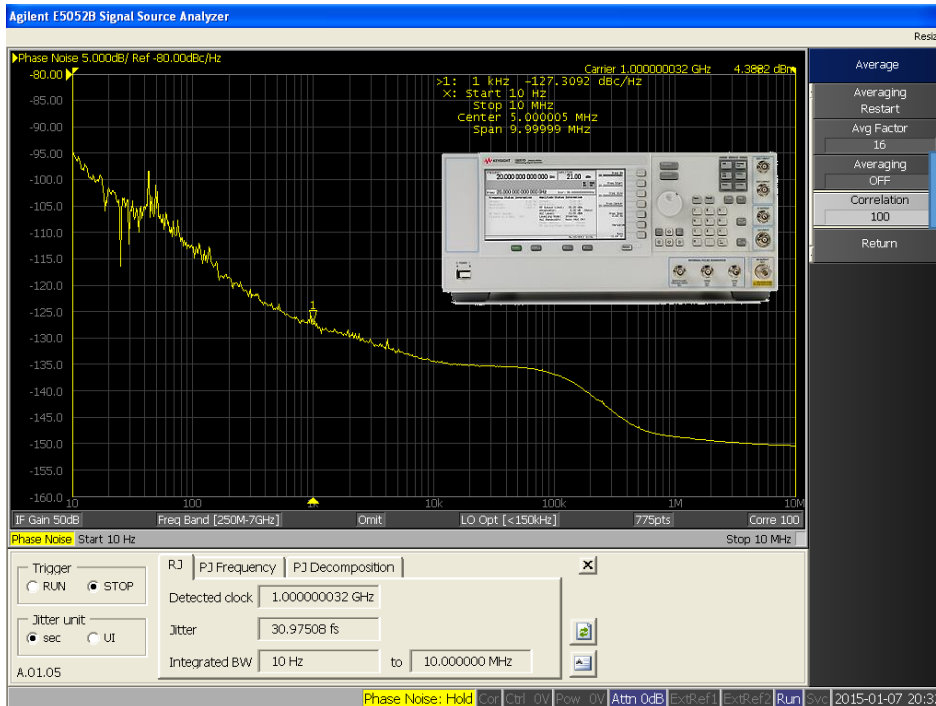

Frequency range	Δt_{rms} [fs]
10...100 Hz	12.4
100 Hz ...1 kHz	5.4
1...10 kHz	5.4
10...100 kHz	11.1
100 kHz...1 MHz	13.0
Total	31.0

→ **Note: jitter values can be added as square root of quadratic sum**

$$\Delta t_{\text{rms}} = \sqrt{\Delta t_{\text{rms},1}^2 + \Delta t_{\text{rms},2}^2 + \dots}$$

→ **Convenient split to relevant ranges**

Variable frequency: direct digital synthesis

- Generate (almost) any frequency starting from a given clock frequency, f_{clk}
- Digitally programmable **in frequency**

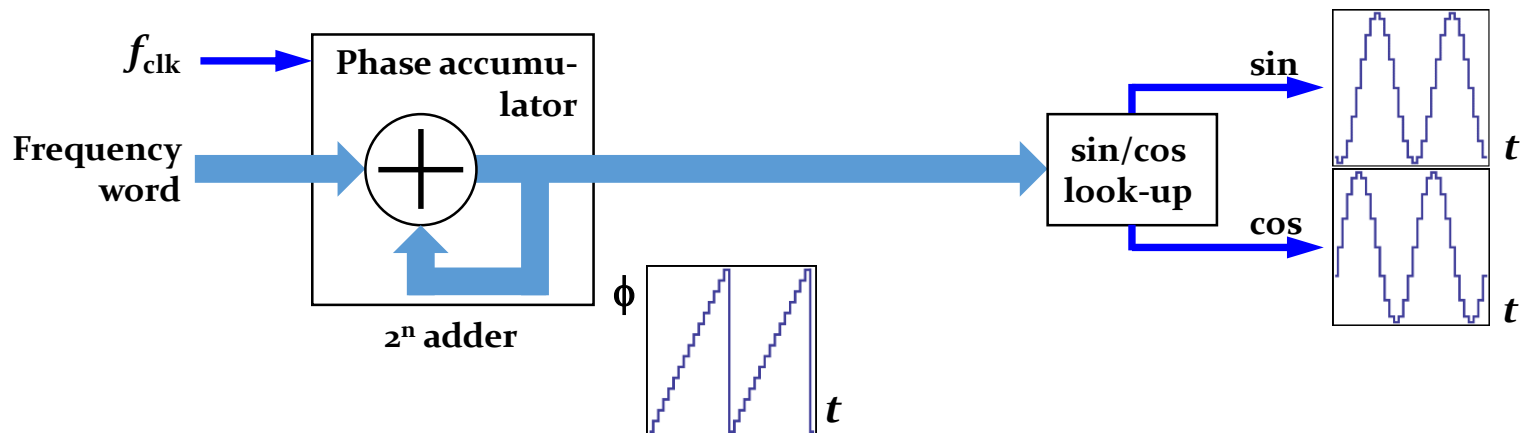
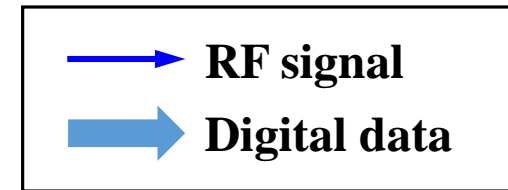

$$f_{\text{out}} = \frac{\text{Frequency word}}{2^n} \cdot f_{\text{clk}}$$

Variable frequency: direct digital synthesis

- Generate (almost) any frequency starting from a given clock frequency, f_{clk}
- Digitally programmable **in frequency and phase**

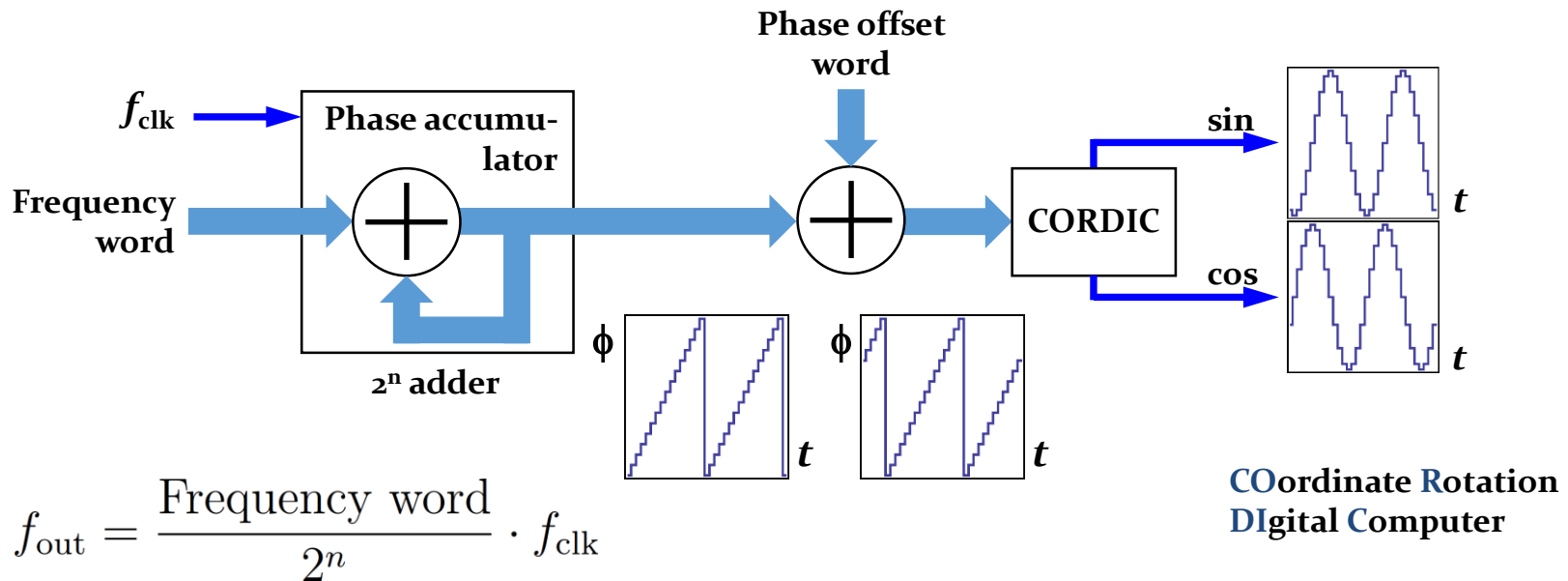
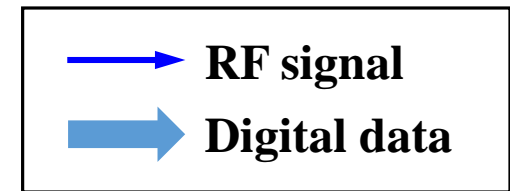

- Two output signals with ideal 90° phase shift
- Output signals are digital data streams

Receivers

I/Q representation of signals

- Any signal can be represented by amplitude A and phase ϕ

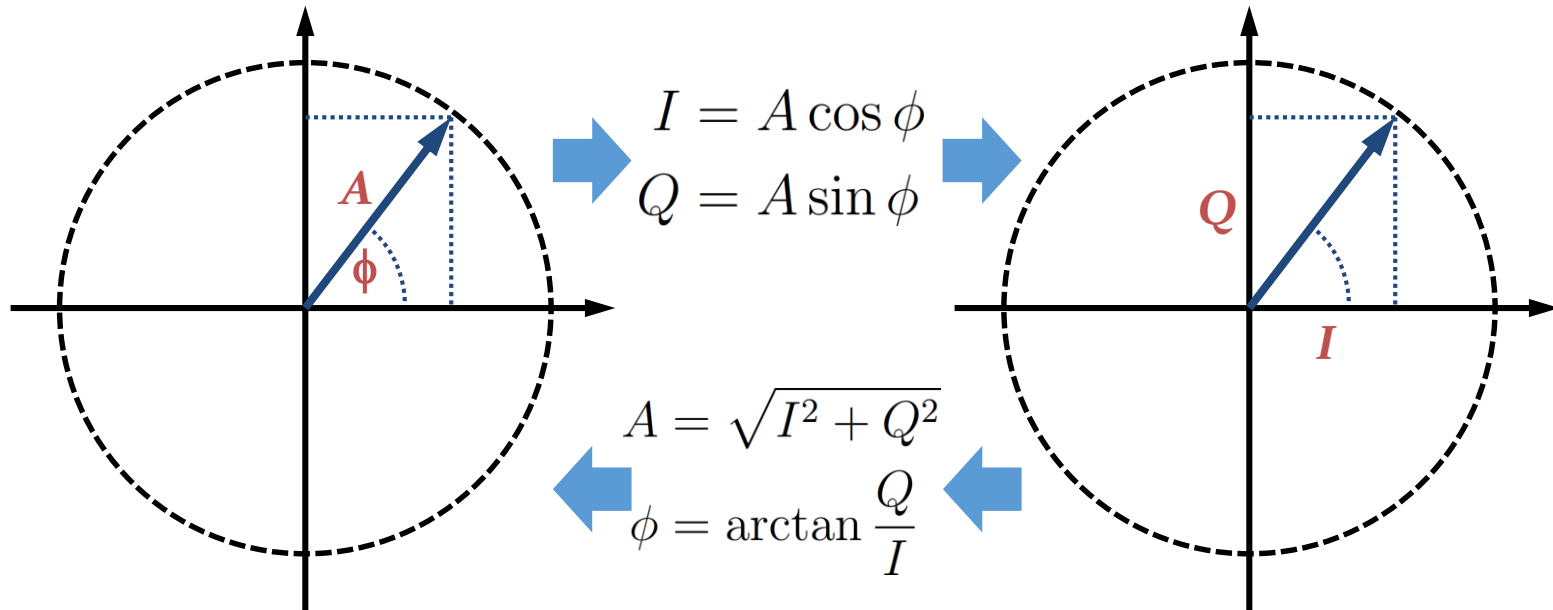

- **In phase, I** and **quadrature, Q** describe the same signal
- **Avoids phase discontinuities** at $0, 2\pi, \dots$

Signal receivers

- Radio with listens to beam or cavity signals
- Listens to amplitude **and phase**

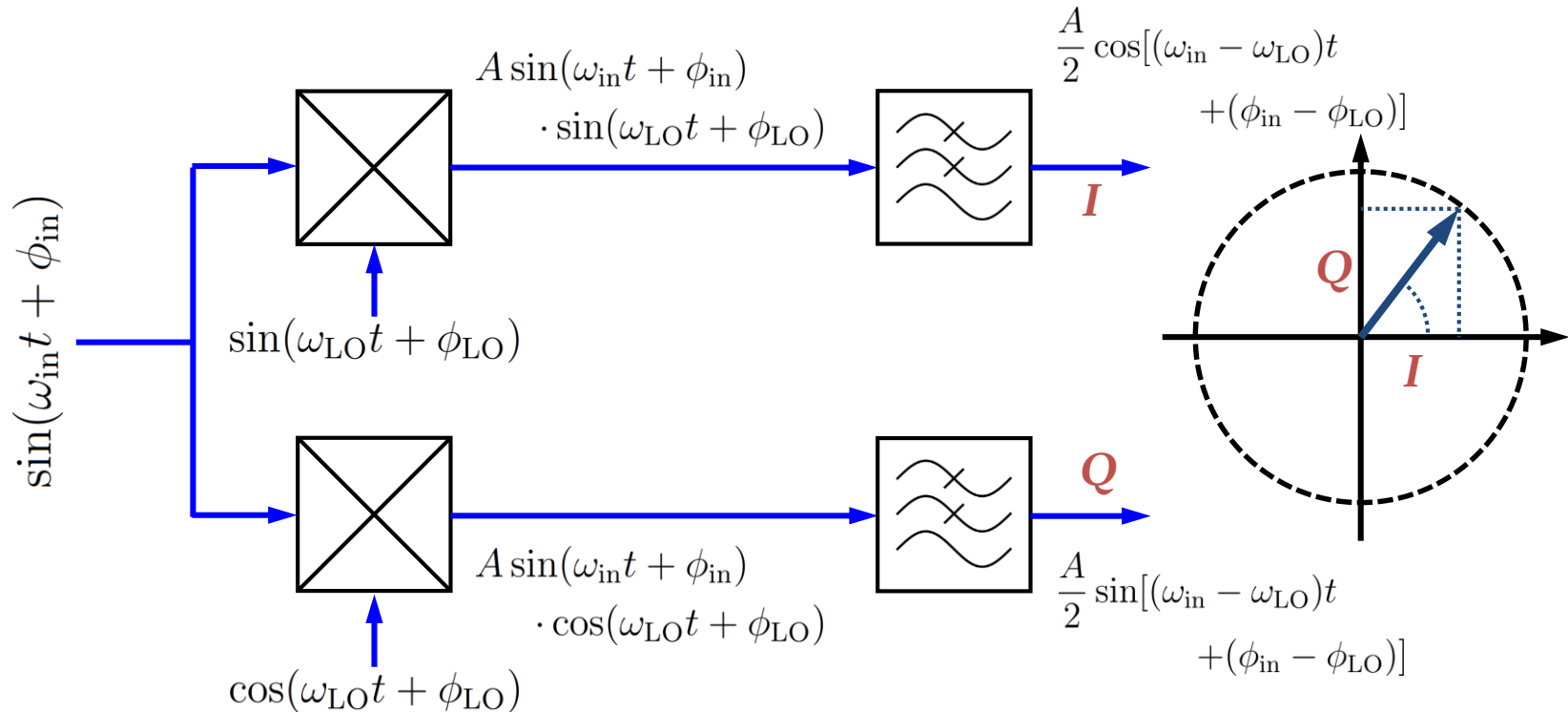

→ With $\omega_{in} \approx \omega_{LO}$ input signal is down-converted to base-band

→ Resulting I/Q vector rotates slowly with $\omega_{in} - \omega_{LO}$

Digital receivers

- No conceptual difference between analogue and digital
- Digitization can be performed at any level

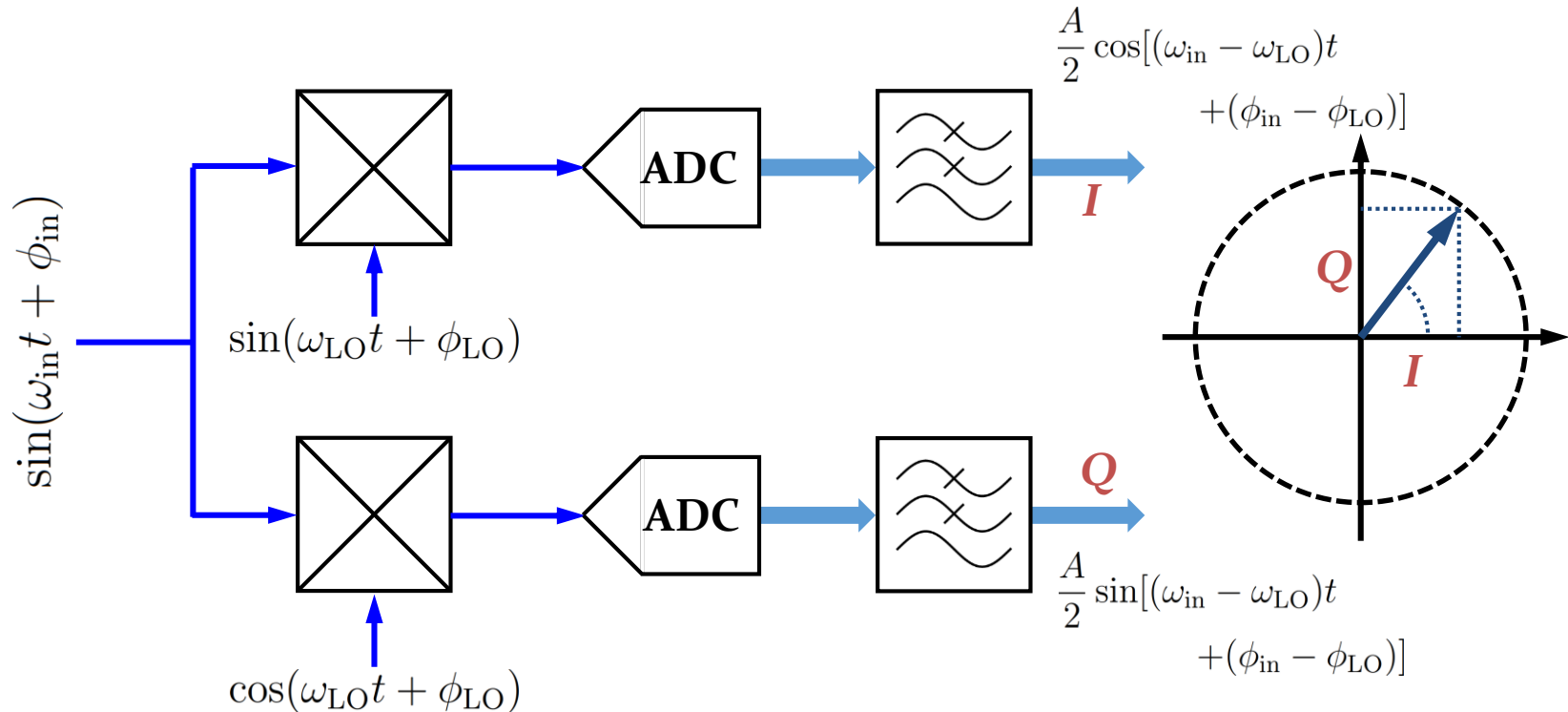

- **Analog down-conversion** of I and Q, then **digital processing**
- **High input frequencies** beyond ADC sampling rates

Digital receivers

- No conceptual difference between analogue and digital
- Digitization can be performed at any level

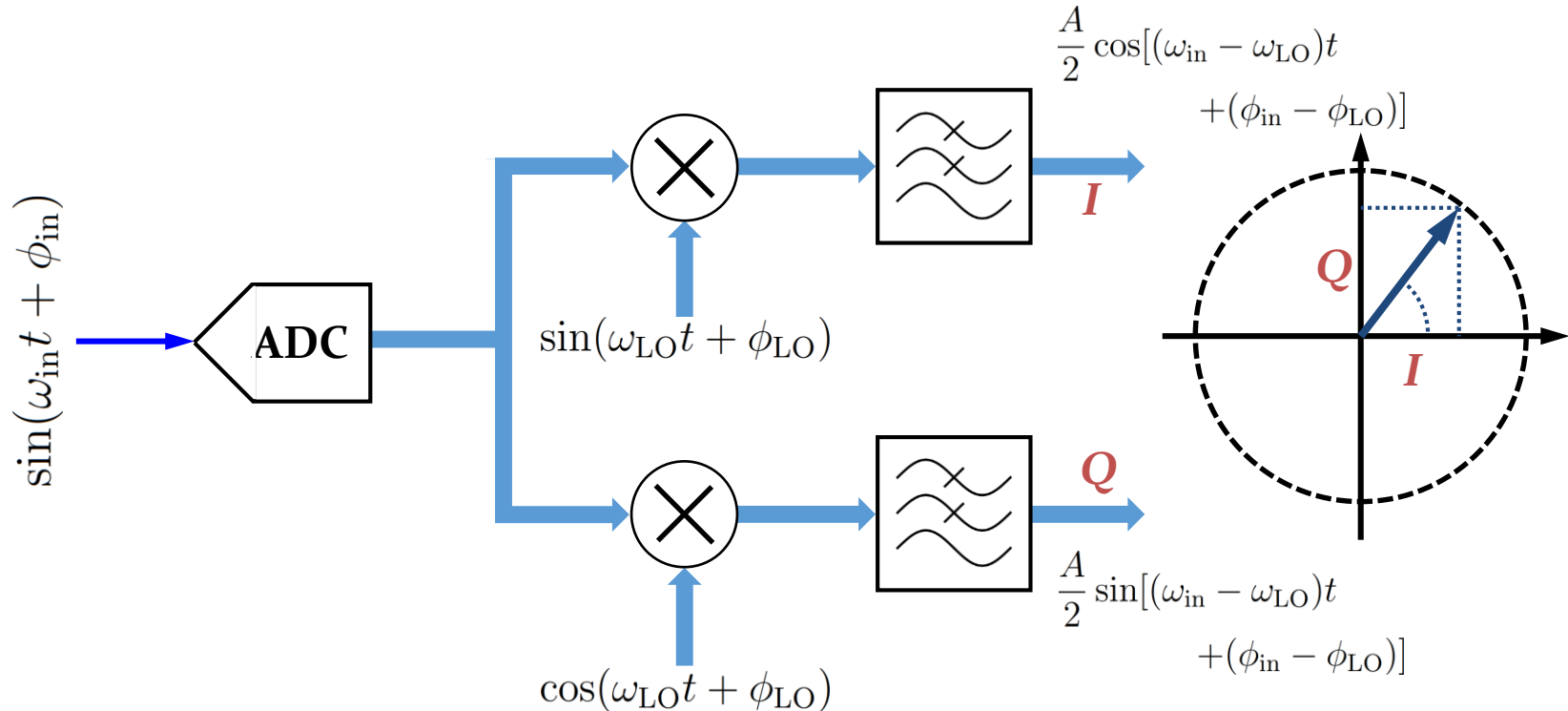

- Analogue mixers become digital multipliers
- All digital receiver
- Theoretically perfect I/Q symmetry

Vector modulator

Invers receiver: vector modulator

- Convert I/Q data into modulated RF signal

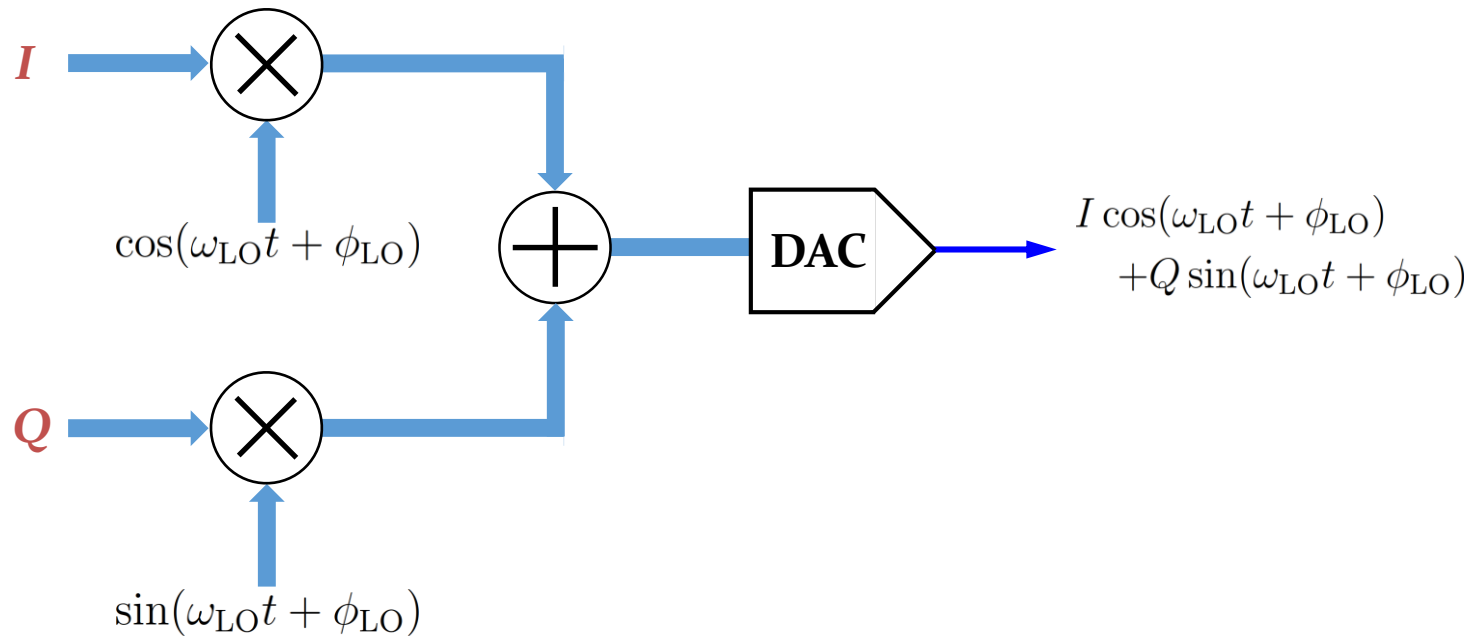

Inverse receiver: vector modulator

- Convert I/Q data into modulated RF signal

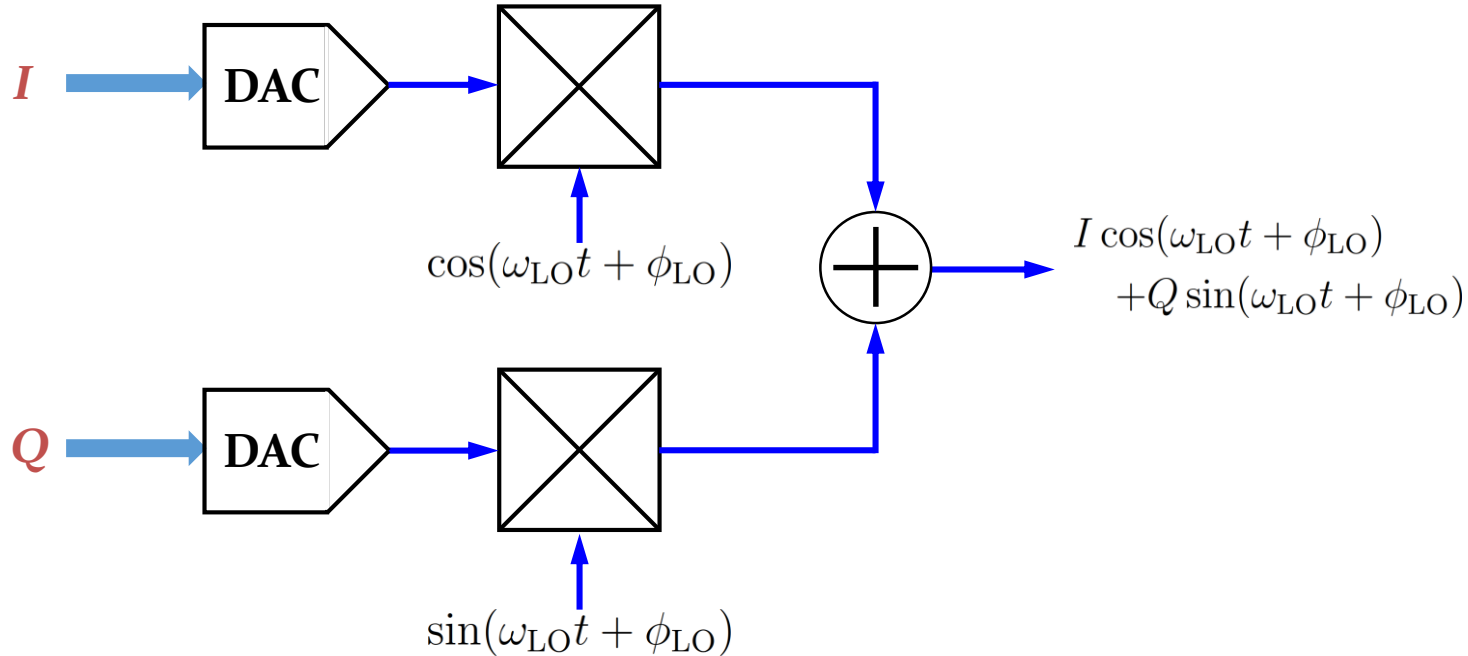

- Perfect **I/Q symmetry** difficult to achieve
- Up-conversion of digital signal to a high RF frequency

Beam phase loop

Electronic phase-locked loop

- Frequency re-generation and multiplication
- Voltage controlled oscillator (VCO) locked in phase to input

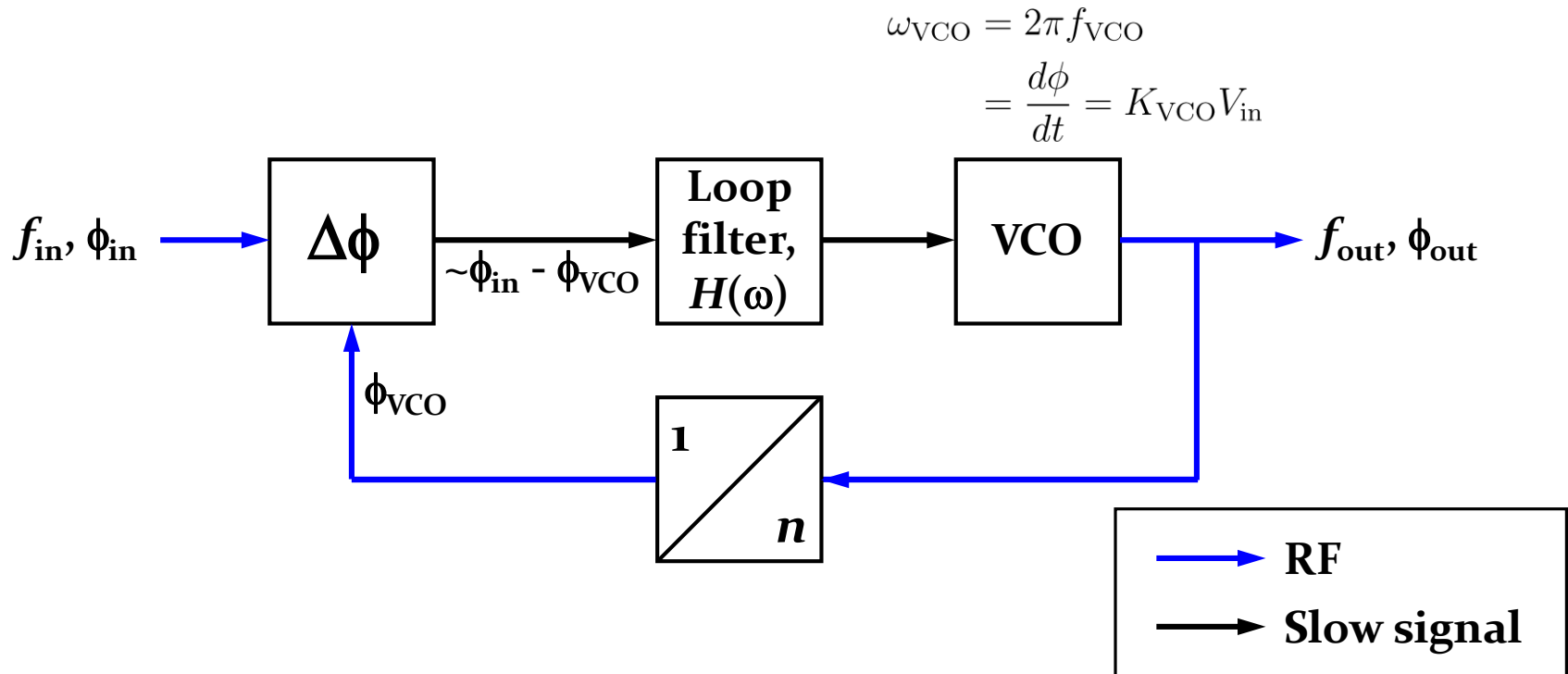

→ Fixed phase relationship:

$$\phi_{\text{out}}/n - \phi_{\text{in}} = \text{const.}$$

→ Optional divider:

$$f_{\text{out}} = n \cdot f_{\text{in}}$$

Beam phase loop

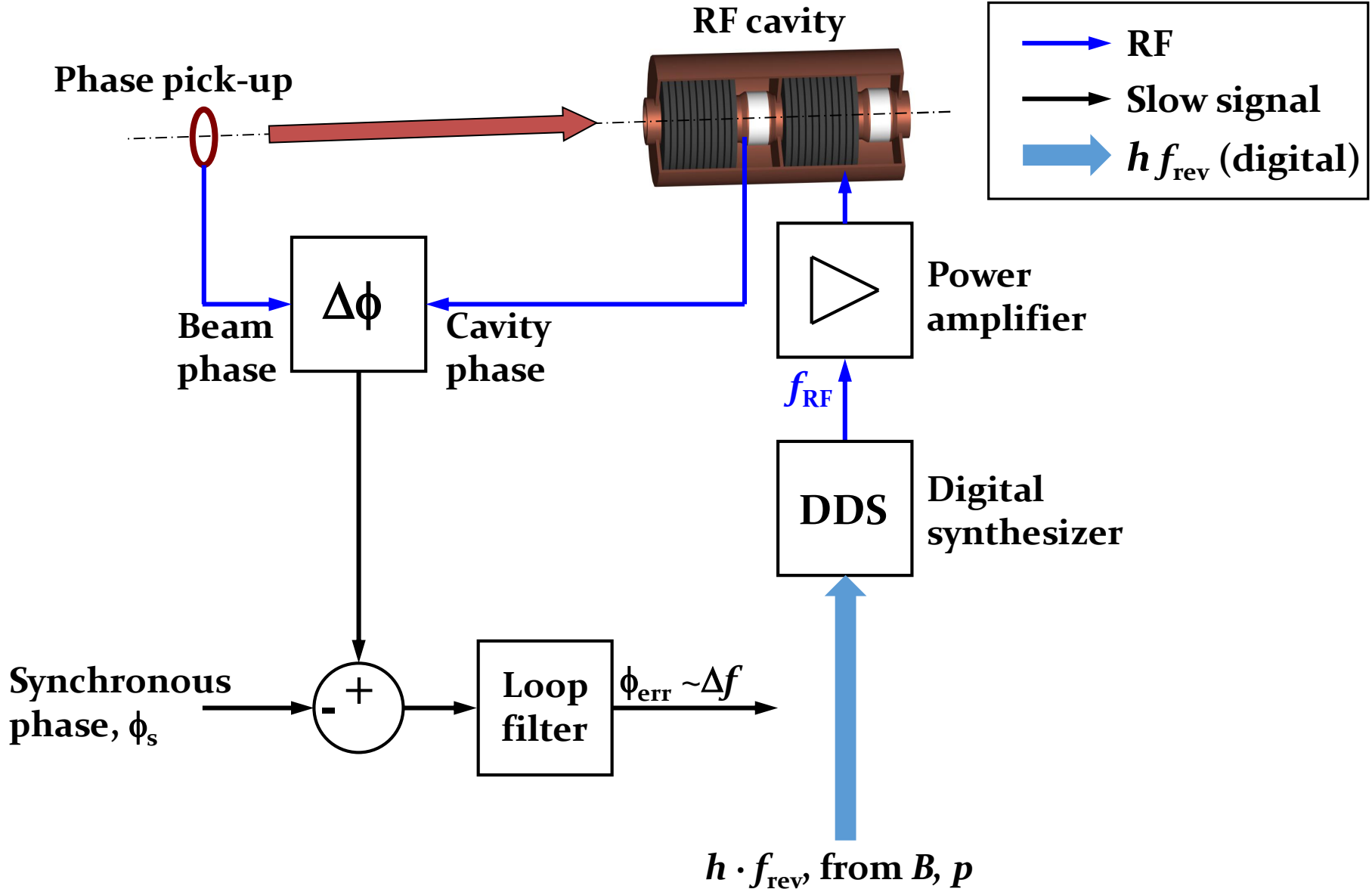

Beam phase loop

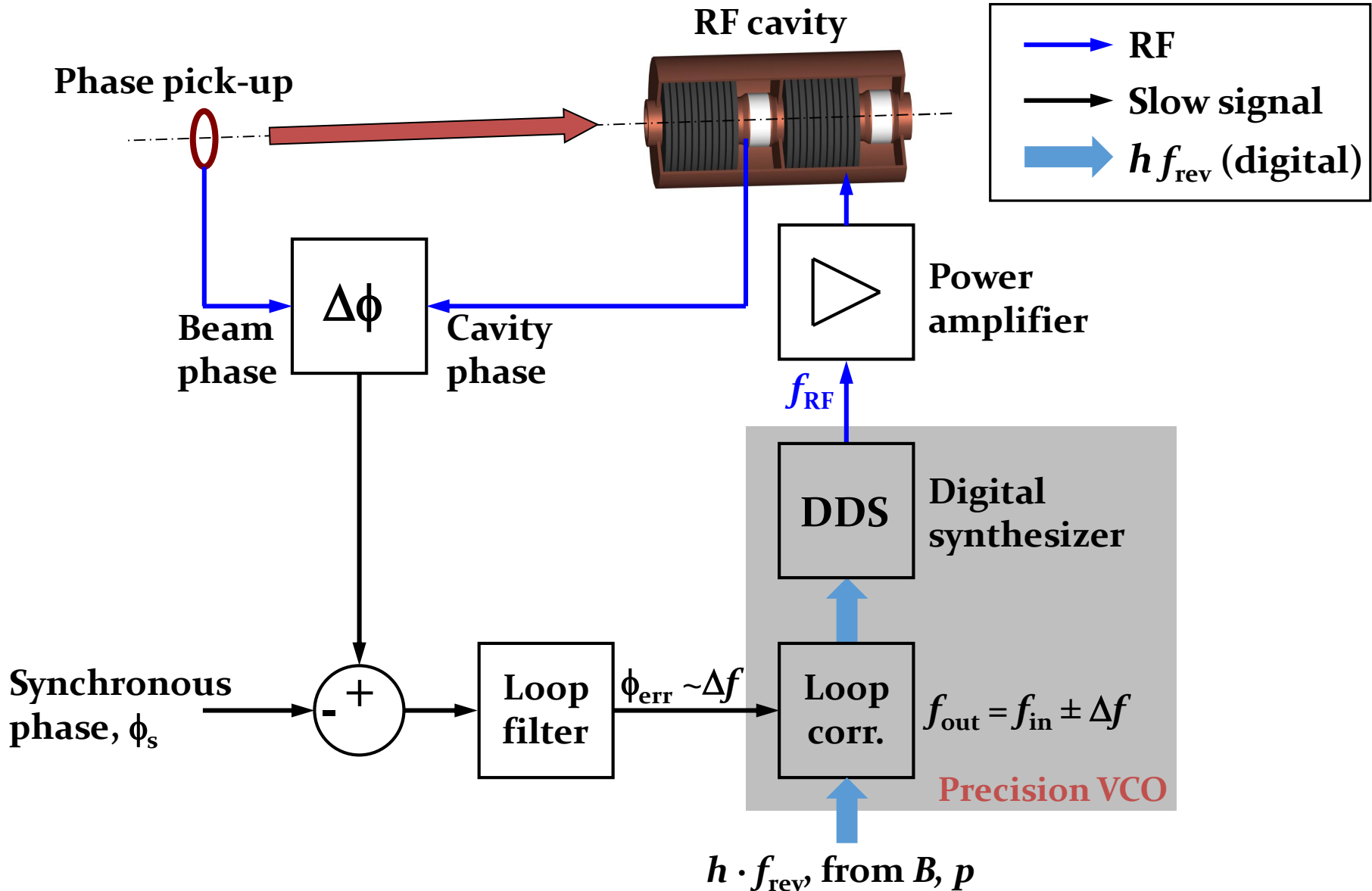

→ Phase-locked loop with beam phase as reference for RF system

Beam phase loop

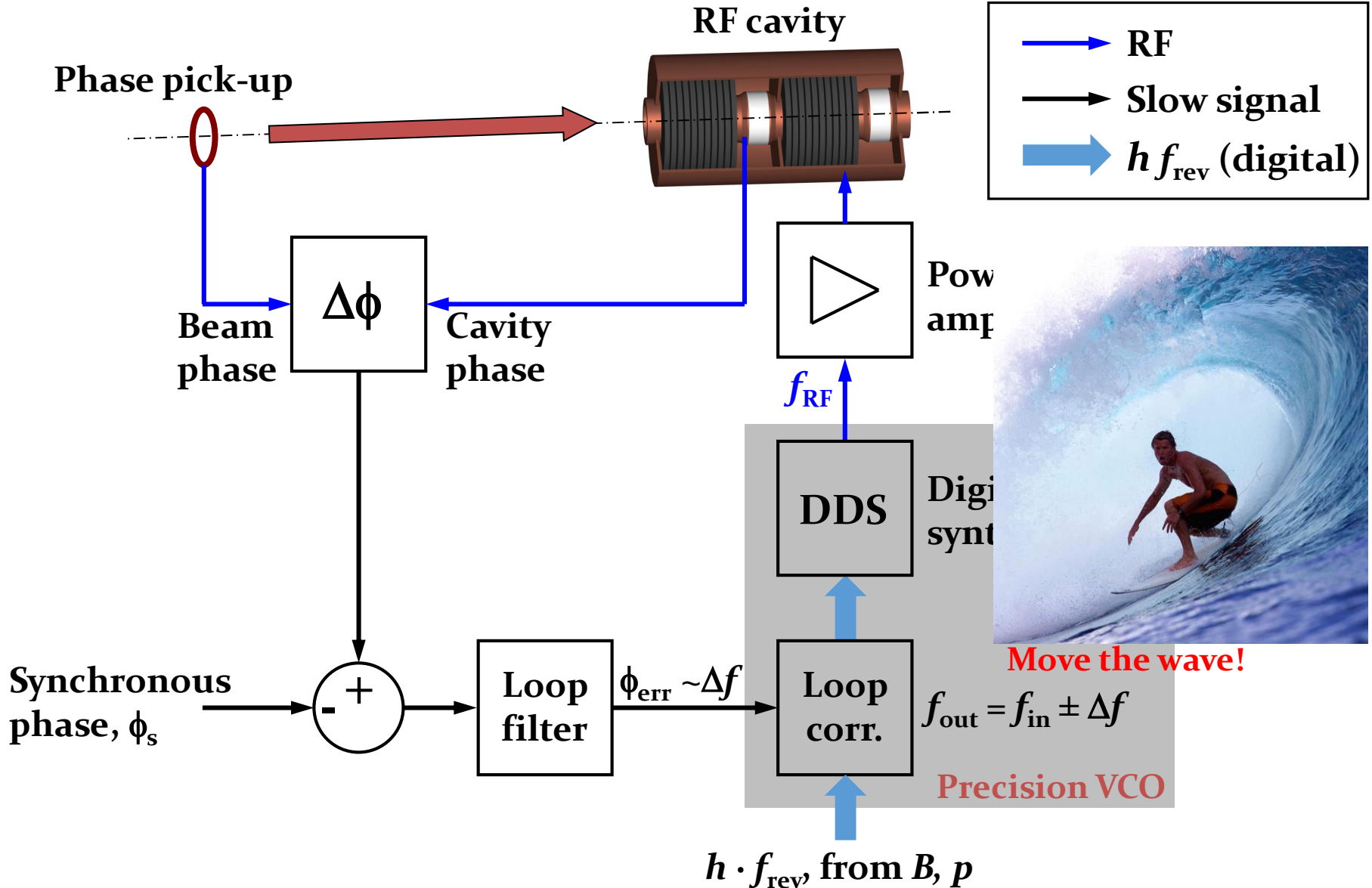

→ Fast control of RF frequency to cavities, **but no slow corrections**

Effect of beam phase loop at injection

- **Example: Injection of a bunch from PS Booster into PS**

90° error, **phase loop off**

Turn# 0

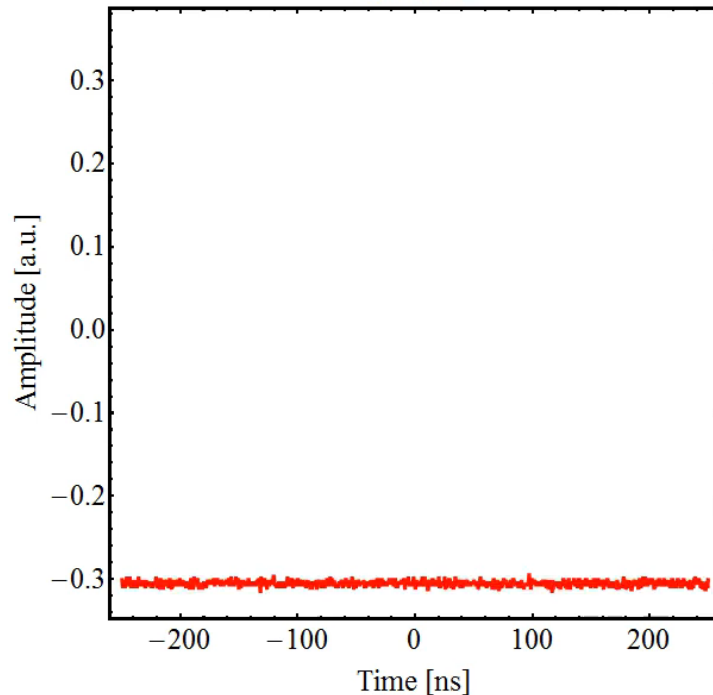

90° error, **phase loop on**

Turn# 0

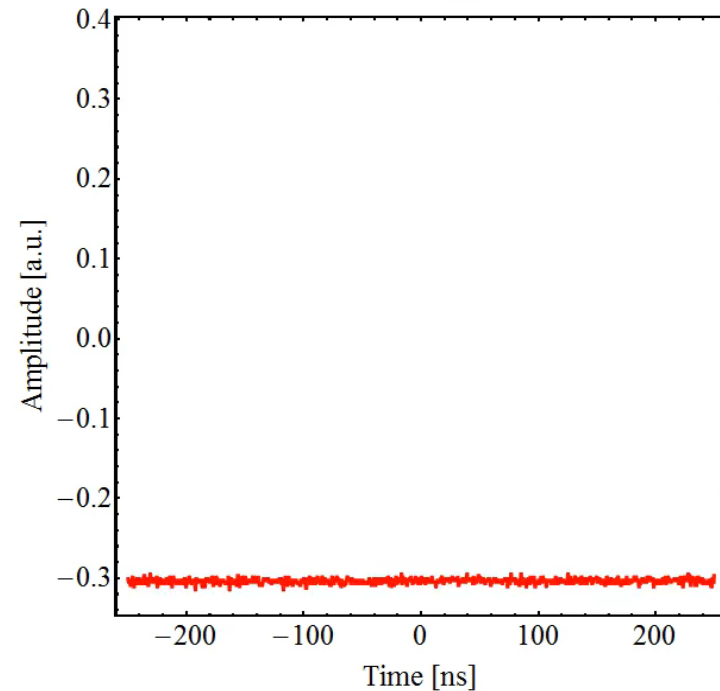

- **Essential in hadron accelerators to keep RF locked to beam**
- **How does this look like in longitudinal phase space?**

Effect of beam phase loop at injection

→ Essential in hadron accelerators to keep RF locked to beam

Bunch in rigid bucket, no loop

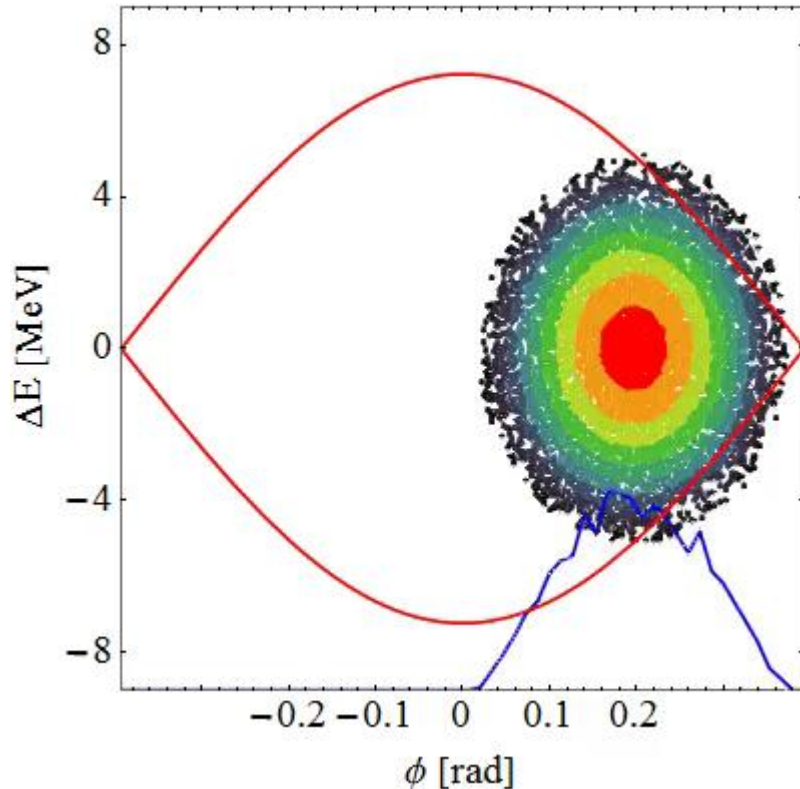

Injection with phase loop

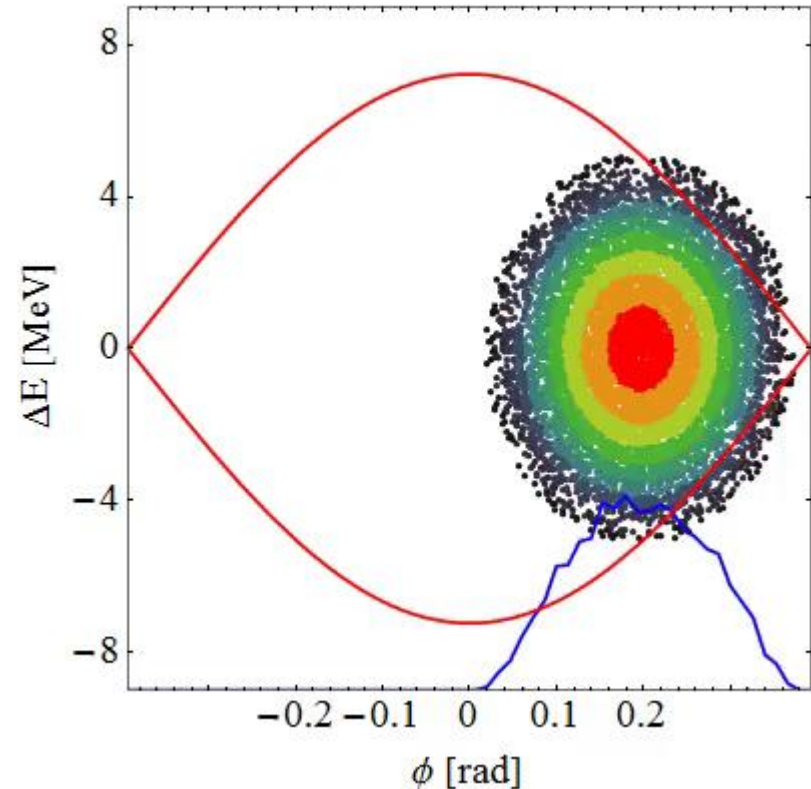

- Even large transients (injection, transition) are controlled
- Only minor longitudinal perturbation

Beam phase loop during acceleration

- What happens with phase loop during acceleration?
- During plateaus the phase between RF and beam is either 0° or 180°
- Fast phase changes well handled, but **need slow frequency correction**
- **Radial or synchronization loop**

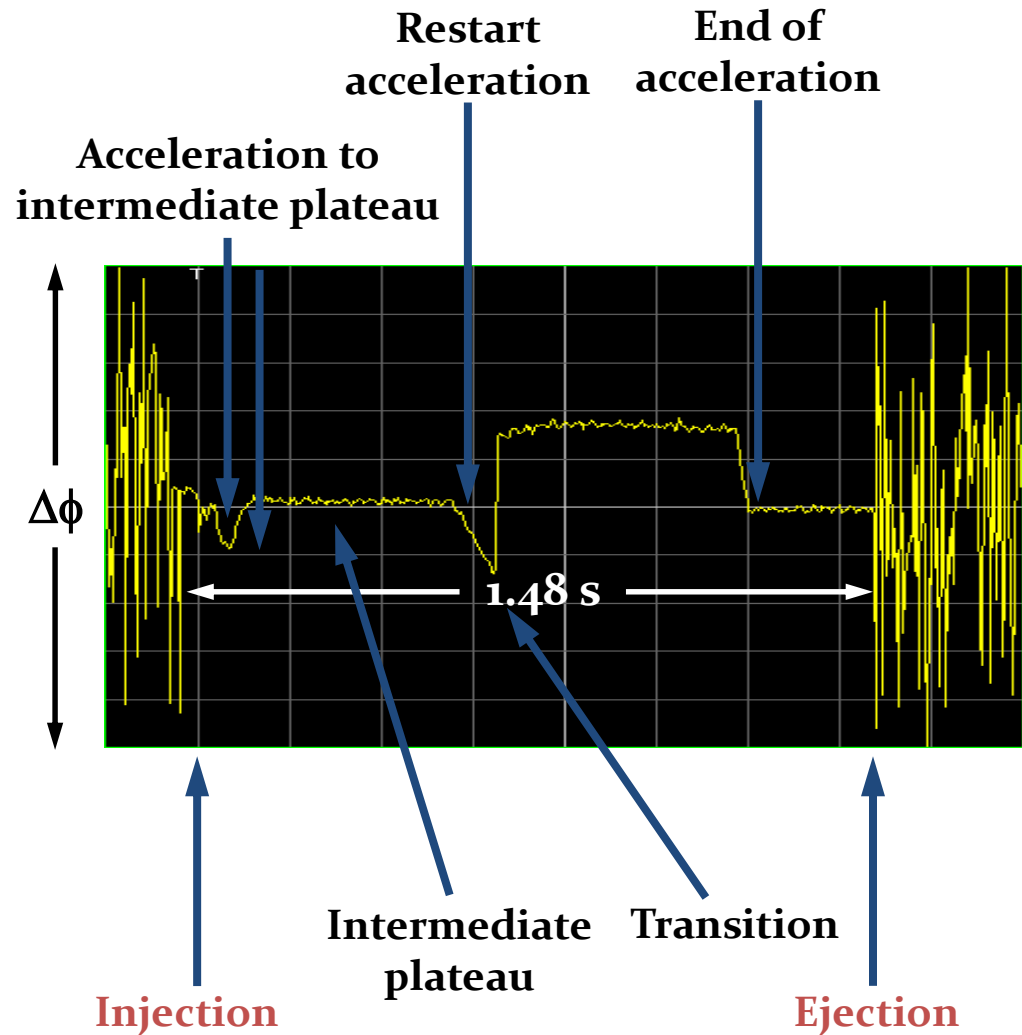

Radial loop

Radial loop

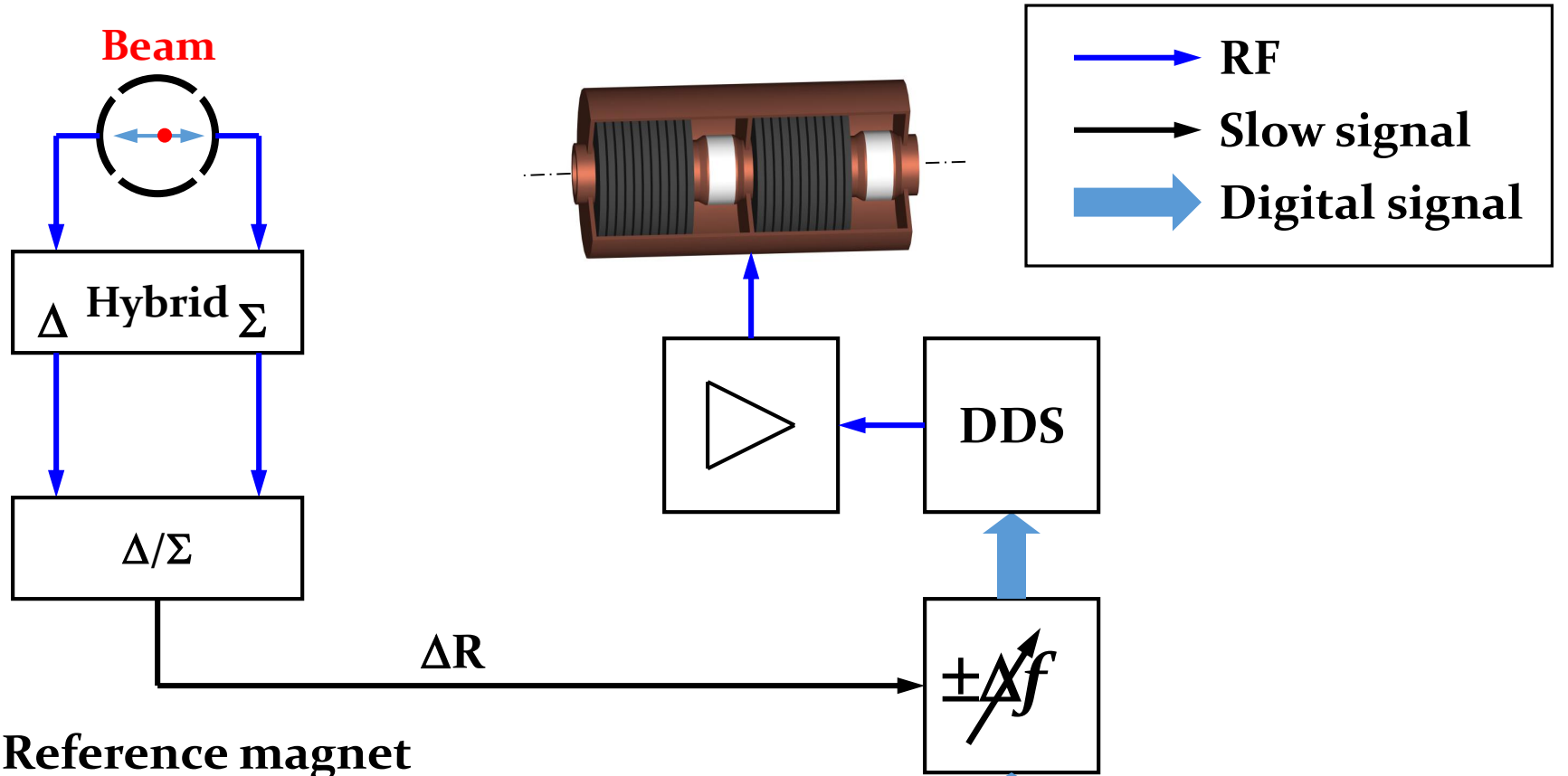

Reference magnet

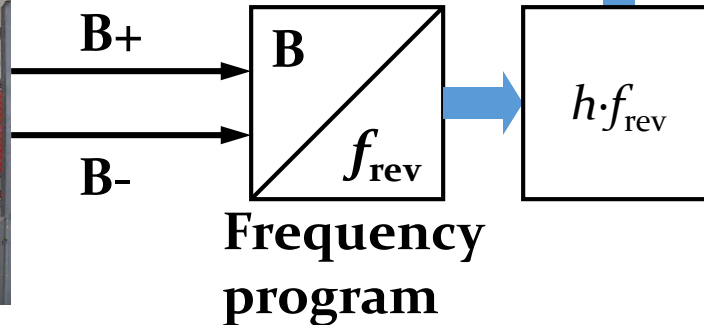

→ Slow correction of average RF frequency

Radial loop

- Slow correction of RF frequency to keep beam centred

Why needed at all with arbitrary precision synthesizers driving the RF system?

→ At transition energy

- Longer path of higher energy particle compensated by higher velocity
- No revolution frequency change for energy offset

$$\frac{\Delta R}{R} = \frac{\gamma^2}{\gamma_{tr}^2 - \gamma^2} \frac{\Delta f}{f}$$

→ Need beam-based frequency correction

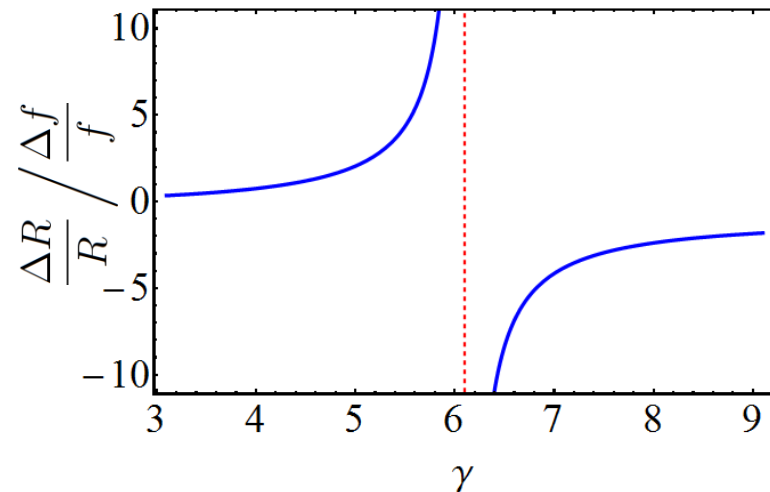

Synchro(nization) loop

Beam phase loop

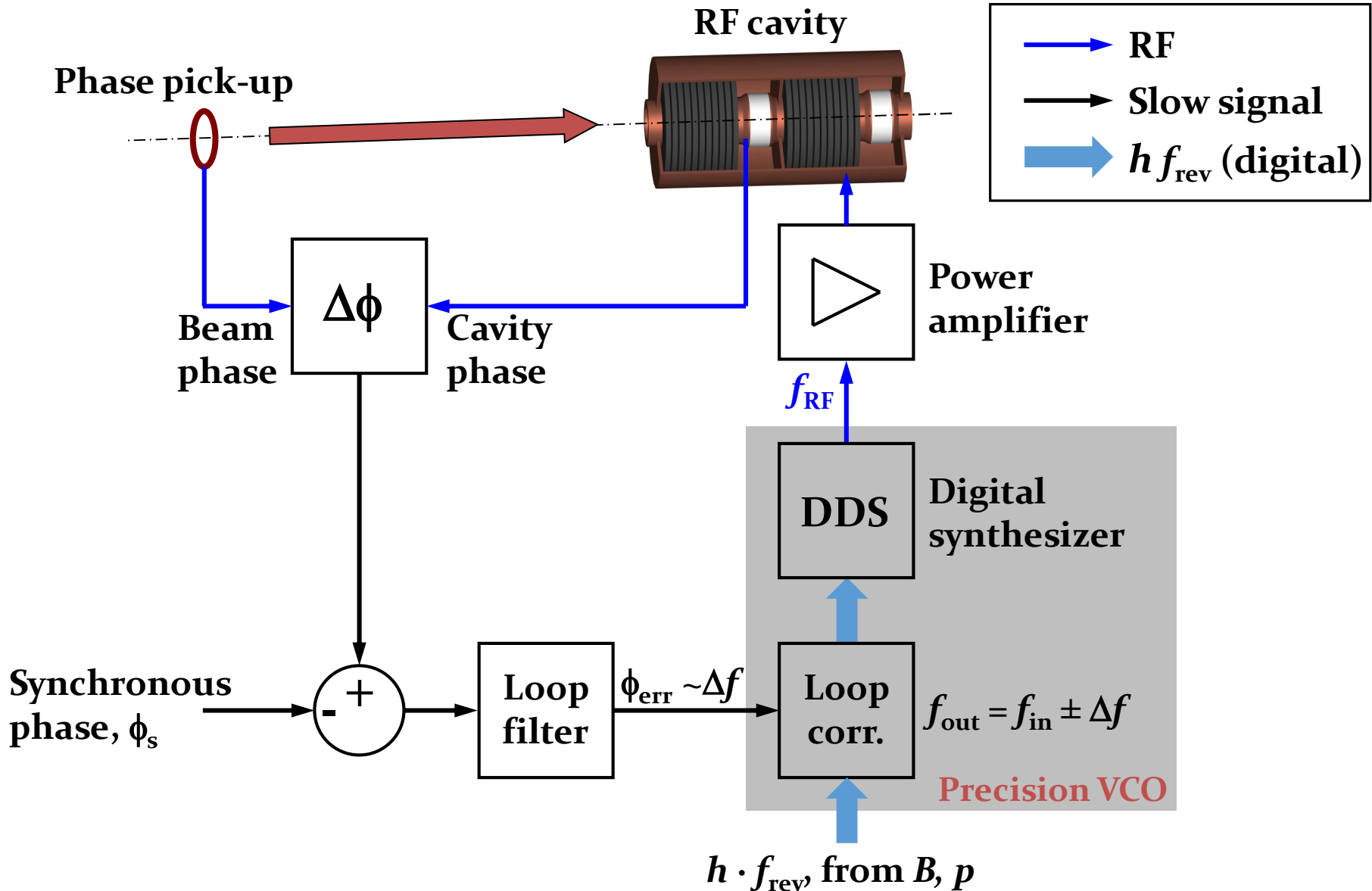

→ Fast control of RF frequency to cavities, **but no slow corrections**

Synchronization loop, **internal** reference

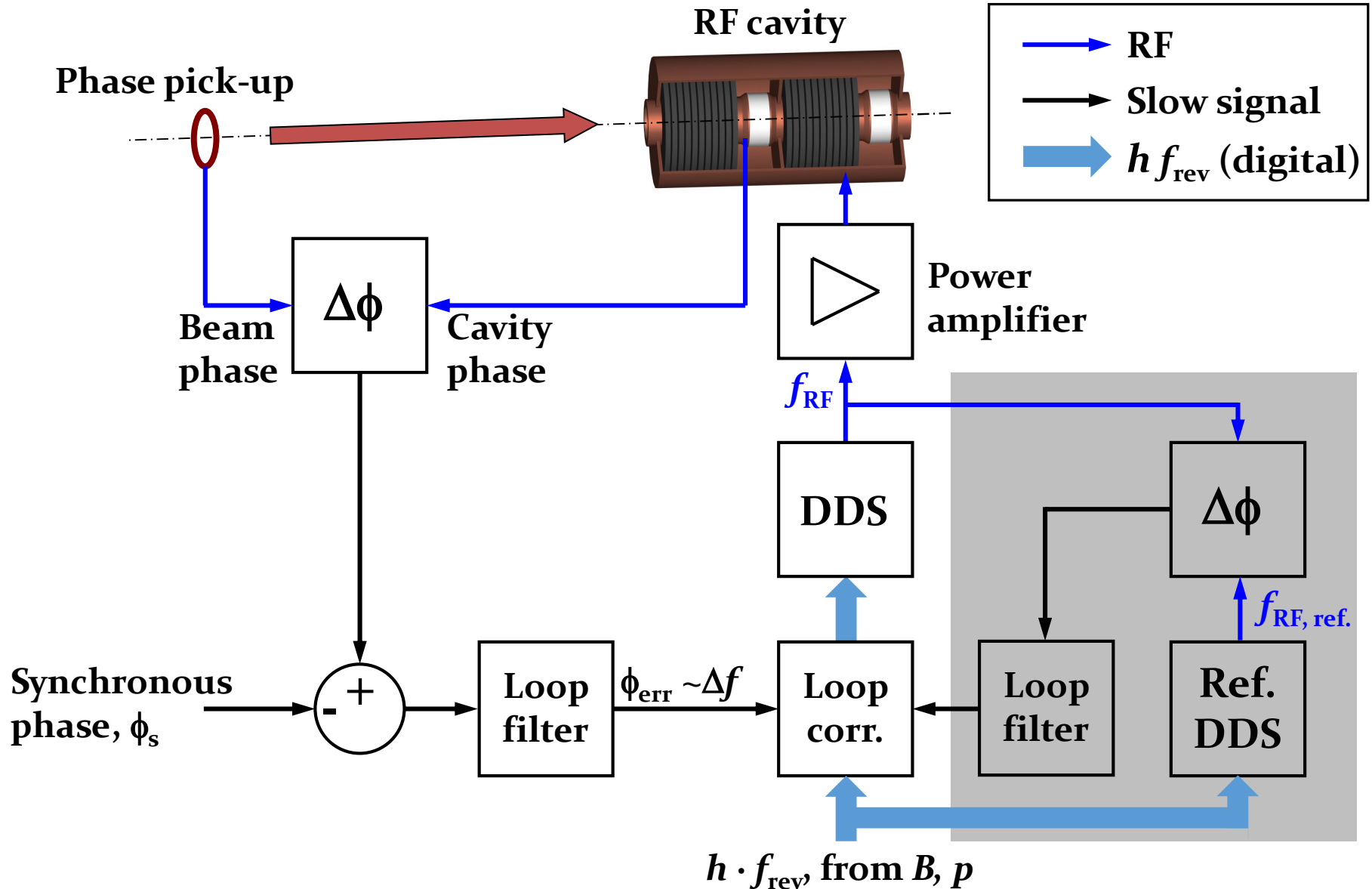

→ Avoids **noise from radial detection** when not crossing transition

Synchronization loop, external reference

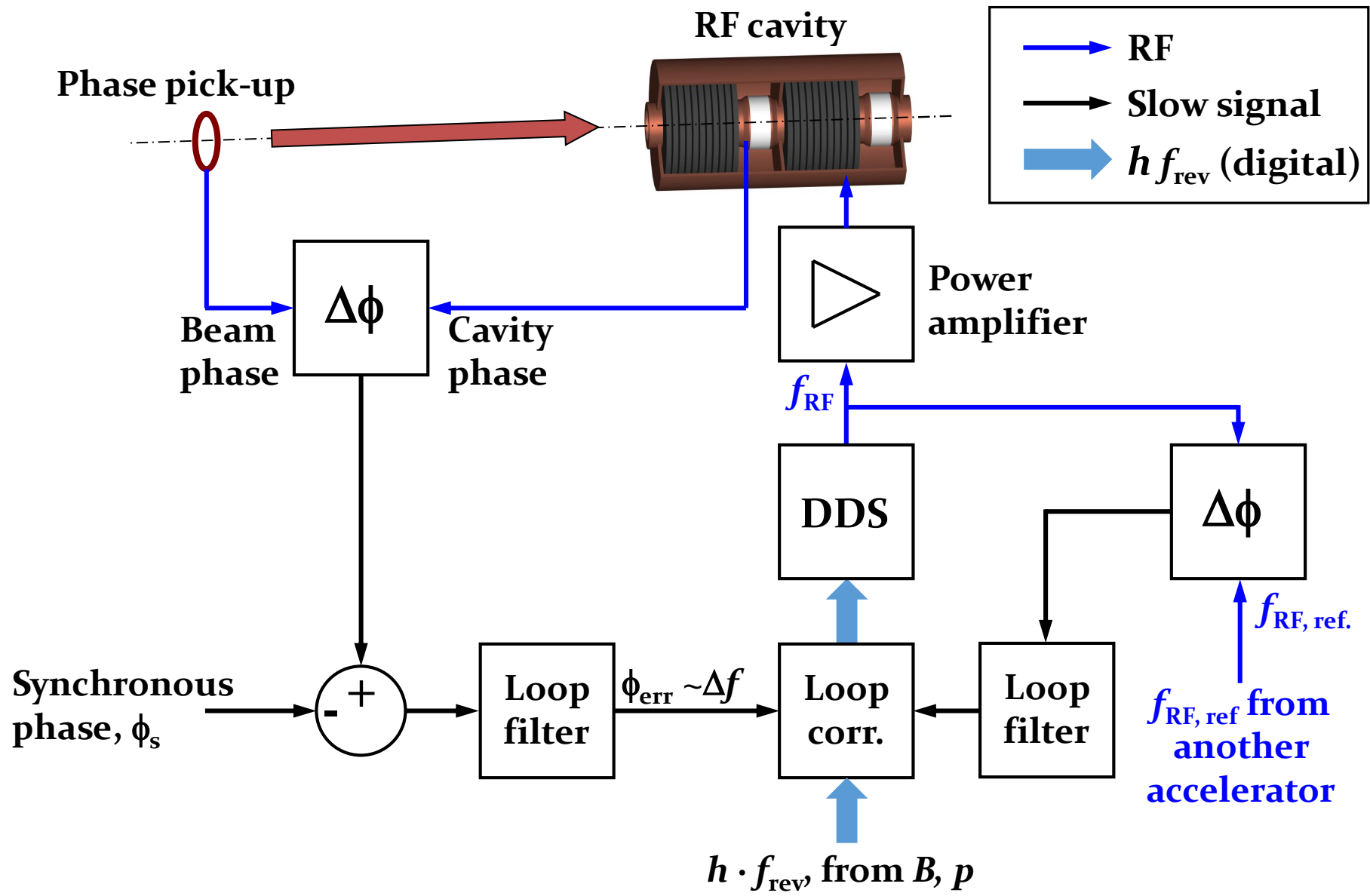

→ Synchronize between accelerators for **transfer**

Before synchronization

- Simple test case of circumference ratio 2: $C_2 = 2C_1$

Target accelerator is
master at transfer

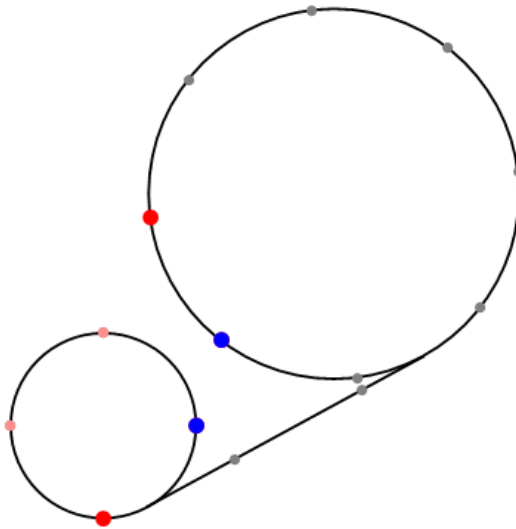

Target accelerator is
master at transfer

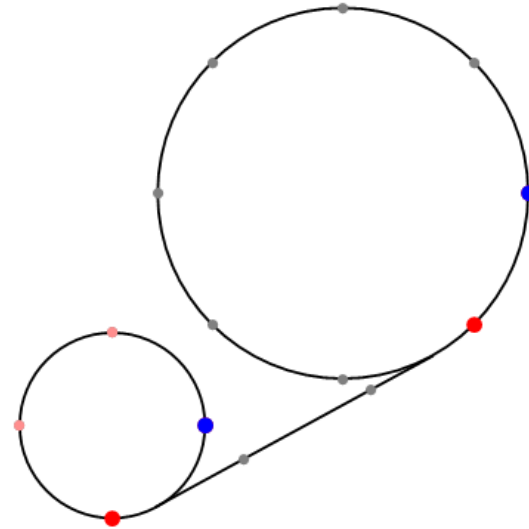

→ Synchronize both accelerator to force: $f_{\text{rev},1} = 2f_{\text{rev},2}$

After synchronization

- Simple test case of circumference ratio 2: $C_2 = 2C_1$

Source or target accelerator
is **master** at transfer

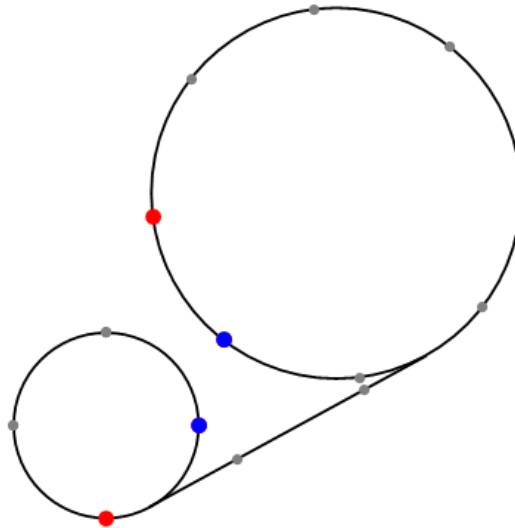

- Revolution frequencies coupled: $f_{\text{rev},1} = 2f_{\text{rev},2}$
- **Ready to extract during every turn of the target accelerator**

Summary

- RF system parameters
- Parameters of RF cavities
- Power amplifier
- **Local feedbacks**
 - **Direct and 1-turn delay feedback**
- **Building blocks of low-level RF systems**
 - **Phase comparison, RF sources and receivers**
- **Basic global feedback loops**
 - **Beam phase, radial and synchronization loops**
 - **Make the beam feel comfortable!**

A big Thank You

to all colleagues providing support, material and feedback

**Maria-Elena Angoletta, Philippe Baudrenghien, Thomas Bohl,
Giorgia Favia, Jörn Jacob, Erk Jensen, John Molendijk,
Eric Montesinos, Gerry McMonagle, Mauro Paoluzzi,
Damien Perrelet, Bernhard Schriefer, Lukas Stingelin,
Fumihiko Tamura, Frank Tecker, Daniel Valuch and many
more...**

**Thank you very much
for your attention!**

References

- D. Boussard, Design of a Ring RF System, CERN SL/91-2 (RFS, rev.), 1991, <http://cds.cern.ch/record/1023436/files/CM-P00065157.pdf>
- E. Montesinos, Accelerators for Medical Applications - Radio Frequency Powering, CERN-2017-004-SP, <http://cds.cern.ch/record/2315172/files/1804.08535.pdf>
- R. Garoby, Low level rf building blocks, CERN-1992-003, 1991, <http://cds.cern.ch/record/225609/files/CM-P00059483.pdf>
- J. W. Wang, G. A. Loew, Field Emission and RF Breakdown in High-Gradient Room-Temperature Linac Structures, SLAC-PUB-7684, 1997, <http://www.slac.stanford.edu/cgi-wrap/getdoc/slac-pub-7684.pdf>
- W. D. Kilpatrick, Criterion for vacuum sparking designed to include both rf and dc, Rev. Sci. Instrum. 28 (1957), 1957, <http://inspirehep.net/record/44645>

Normalized Hamiltonian representation

- **For a single harmonic RF system**

$$H(\phi, \dot{\phi}) = \frac{1}{2} \dot{\phi}^2 + \frac{\omega_s^2}{\cos \phi_S} [\cos \phi_S - \cos \phi + (\phi - \phi_S) \sin \phi_S]$$

with $\phi = \phi_S + \Delta\phi$ **it becomes**

$$H(\Delta\phi, \dot{\phi}) = \frac{1}{2} \dot{\phi}^2 + \frac{\omega_s^2}{\cos \phi_S} [\cos \phi_S - \cos(\phi_S + \Delta\phi) - \Delta\phi \sin \phi_S]$$

using $\cos(\phi_S + \Delta\phi) = \cos \phi_S \cos \Delta\phi - \sin \phi_S \sin \Delta\phi$

$$\simeq \cos \phi_S \left(1 - \frac{1}{2} \Delta\phi^2 \right) - \sin \phi_S \Delta\phi$$

this simplifies to $H(\Delta\phi, \dot{\phi}) \simeq \frac{1}{2} \dot{\phi}^2 + \frac{1}{2} \omega_s^2 \Delta\phi^2$

Cascaded integrator-comb filter (CIC)

- Efficient implementation of low pass filter
- Standard form with sampling rate decimation: $f_{\text{clk}} \rightarrow f_{\text{clk}}/d$

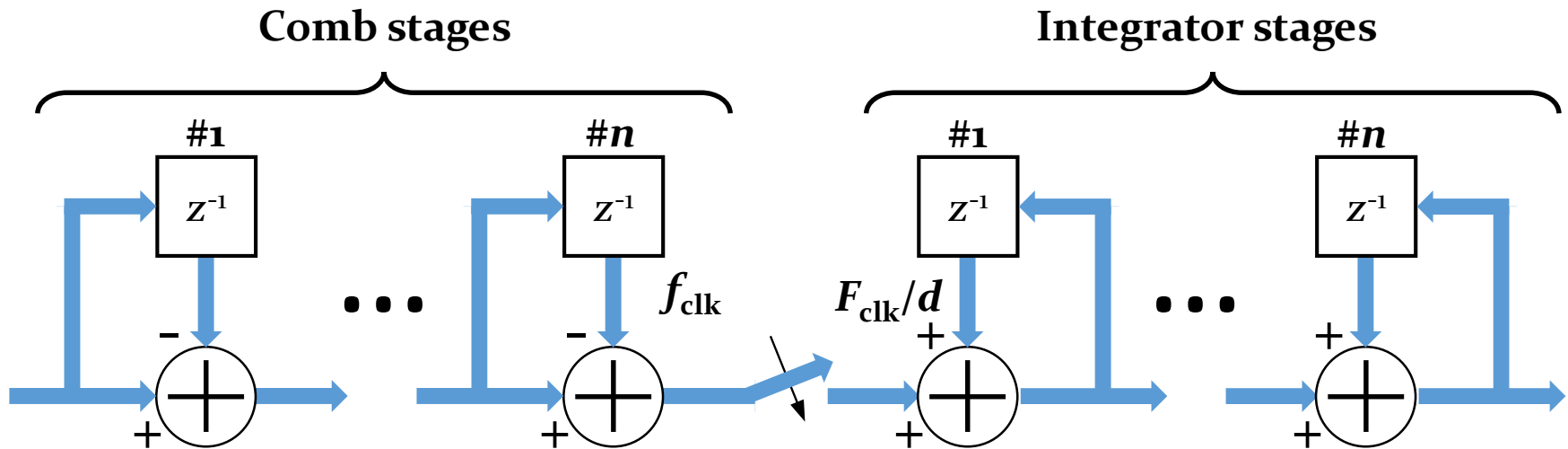

$$H(z) = \left(\frac{1 - z^{-d}}{1 - z^{-1}} \right)^n \quad \begin{array}{l} n: \text{filter order} \\ d: \text{decimation ratio} \end{array} \quad z = e^{2\pi i \cdot f / f_{\text{clk}}}$$

- Easy to implement in programmable logic: **no multipliers**
- **Only adders and shift registers**

Cascaded integrator-comb filter (CIC)

Why particularly interesting for circular accelerators?

- Choose clock frequency, $f_{\text{clk}} = 2^m f_{\text{rev}}$ and decimation $d = 2^m$
- Notches at all multiples of f_{rev} **except zero**
- Linear phase $\phi(f)$ → filter behaves like a constant delay

Example:

$$f_{\text{clk}} = 128 f_{\text{rev}},$$

$$d = 128,$$

$$n = 3$$

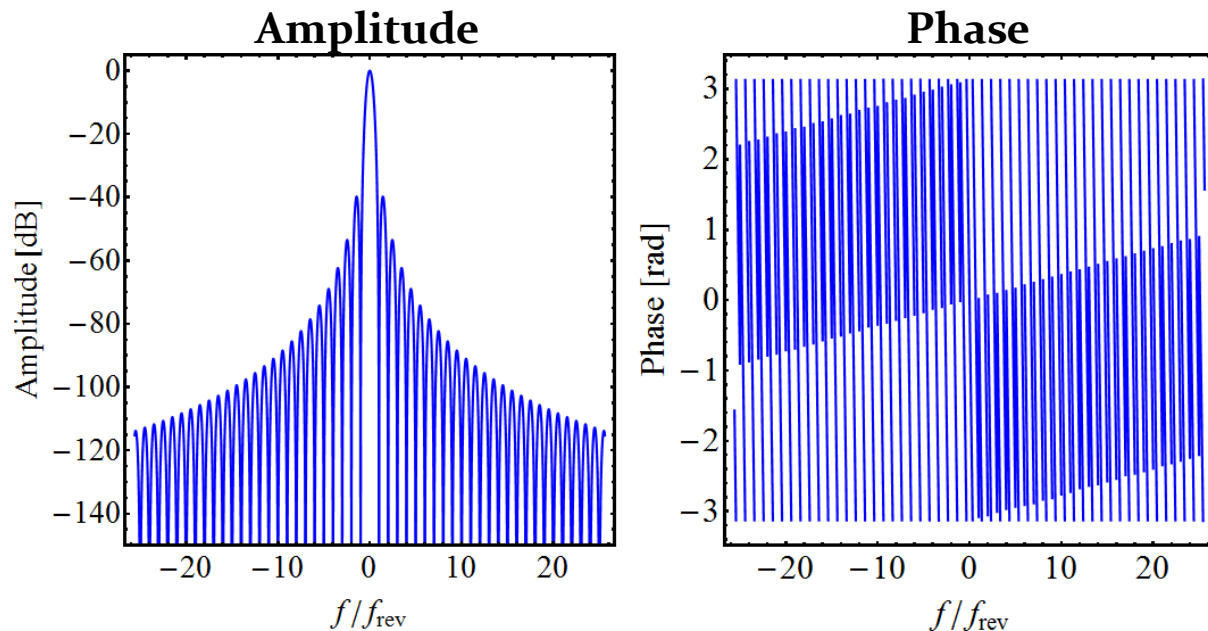

Ideal low-pass filter in digital receivers

→ Filter selected multiple of f_{rev} while suppressing all others

Transmission of reference signals

- Thermal drift of long coaxial cables or optical fibres

- Thermal coefficient of delay:

$$\text{TCD} = \frac{\Delta\tau}{\tau} \cdot \frac{1}{\Delta T} = \frac{\Delta\phi}{\phi} \cdot \frac{1}{\Delta T}$$

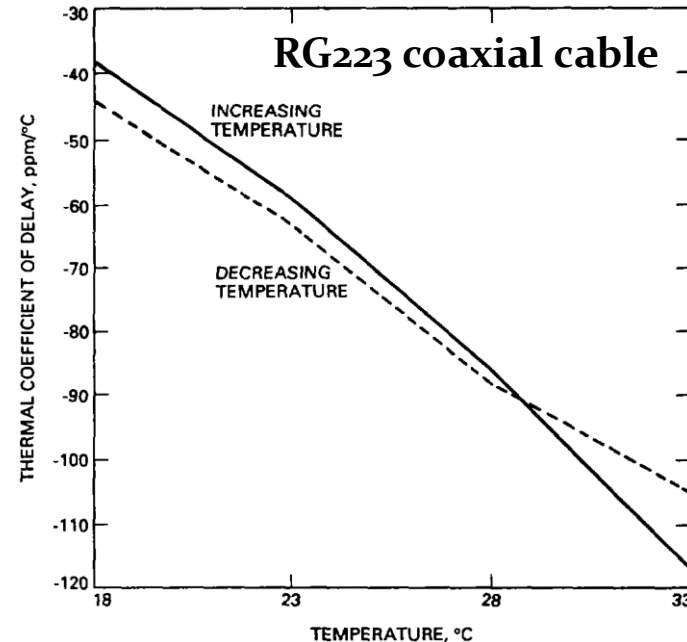

- Example: 2 km long RG223 cable with ~10 μs delay
 - ΔT of only 1° C (room temperature) changes delay by ~0.5 ns
 - 1.8° at 10 MHz (CERN PS), but 73° at 400 MHz (LHC)
- Optical fibres are typically 10...100 times more stable
- What to do if this is still not sufficient?

Simple synchronization process

1. Move beam to off-momentum (B const.): $\frac{df}{f} = \frac{\gamma_{tr}^2 - \gamma^2}{\gamma^2 \gamma_{tr}^2} \frac{dp}{p}$
 - Well defined frequency difference between accelerators
2. Measure azimuth error, when beam at correct azimuth
 - Close synchronization loop
 - Moves beam to ref. momentum

