

Introduction to the Course on Beam Position Measurement CAS on Beam Instrumentation 2018

M. Gasior & R. Jones (CERN) Tuusula, Finland, 2nd – 15th June 2018

Purpose

The aim of this course is to give you a basic understanding of the measurement principles, fundamental concepts and related technological aspects of deriving beam position in a particle accelerator. An interactive simulation tool will allow you to generate beam signals and construct your own virtual monitor and acquisition systems. The simulation course will be complemented by a practical laboratory session, where you will be able to physically measure what you've been simulating, to further enhance your understanding of the concepts behind such systems.

Introduction to the Simulation Tool:

1. The Workspace

The simulation tool is based on a main workspace (Fig. 1) where the components to be simulated are put by selecting the appropriate circuit drawing block. The blocks are connected using wires, with the signals on any wire capable of being probed. The Circuit Drawing Block contains most of the standard components required to simulate a beam and build a beam position monitor acquisition system.



Fig. 1: Workspace with circuit drawing Block open

1.1 Connecting Items

Once selected and dropped onto the simulator workspace the output from one ITEM can be provided to the input of another ITEM by clicking on Place Wire in the Circuit Drawing menu. Clicking on an input or output node (small icon rectangles within each ITEM) then generates a wire, which can be terminated by clicking on another input or output node. REMEMBER to click on Exit Place Wire when you've finished with the wiring.

1.2 Probing Signals

To look at a signal at any point in the acquisition chain requires a probe to be placed on a wire (or a wire to be joined to a probe). Select Place Probe from the Circuit Drawing menu & click on the wire to be probed, or drop the probe with a left click & attach the automatically generated wire to the point to be probed.

1.3 Saving and Loading Circuits in the Workspace

A circuit can be saved at any time by clicking on the Save button in the Circuit menu. This will save the circuit and the parameters currently attributed to all components. A saved circuit can be retrieved using the Load button in the Circuit menu.

2. Component Properties

Once selected and dropped onto the simulator workspace the properties of each component can be modified by right clicking on the item and selecting "properties" from the dropdown menu. For example the beam itself is represented by the "Beam" component in the "Sources" section of the circuit drawing Block menu. This appears as ITEM1 in the workspace shown in Fig. 1. The "properties" of this component (Fig. 2) allows the user to set all the parameters necessary to simulate most standard beam types.

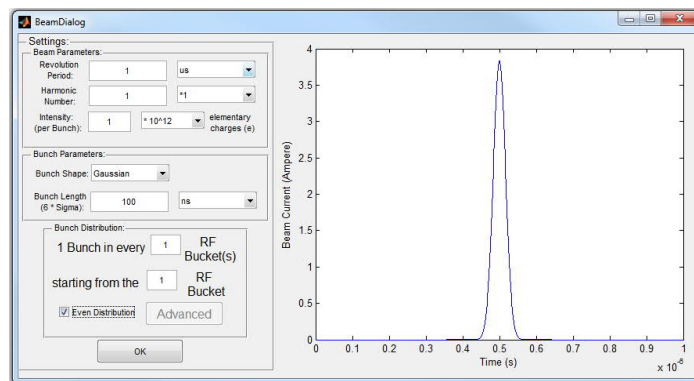

Fig. 2: BeamDialog showing the current properties of the BEAM generator component

In the example of Fig. 2 the beam is defined to be a single Gaussian bunch of length (6 x sigma) = 100ns containing 10¹² charges. The revolution period is 1 microsecond (revolution frequency of 1MHz), with a harmonic number (number of RF buckets per revolution period) of 1, corresponding to an RF frequency which is also 1MHz. For higher harmonic numbers it is possible to further define how many bunches there are per turn and where these bunches are positioned, using the Bunch Distribution panel which can be opened by unselecting the "Even Distribution" checkbox.

All the ITEMS in the Circuit Drawing Block will open similar property windows that allow the user to define their parameters.

3. Simulating the Circuit

Once you're happy with the model, and have placed probes at all locations that you wish to monitor, the simulation can be launched. To do this press the Simulate button in the Simulate Actions menu. Once the simulation is complete you will be asked to name the output data before the Results Viewer (Fig. 3) is automatically opened to show the results.

4. Displaying Results

The Results Viewer is comprised of two graphs, the top graph showing the time evolution of the signal at each probe and the lower graph showing the frequency content of the signal at each probe (i.e. the signal magnitude spectrum calculated from the Fourier Transform of the time domain data).

Each time you simulate the new results will be added to the existing graphs. This allows you to compare results from circuits with different settings.

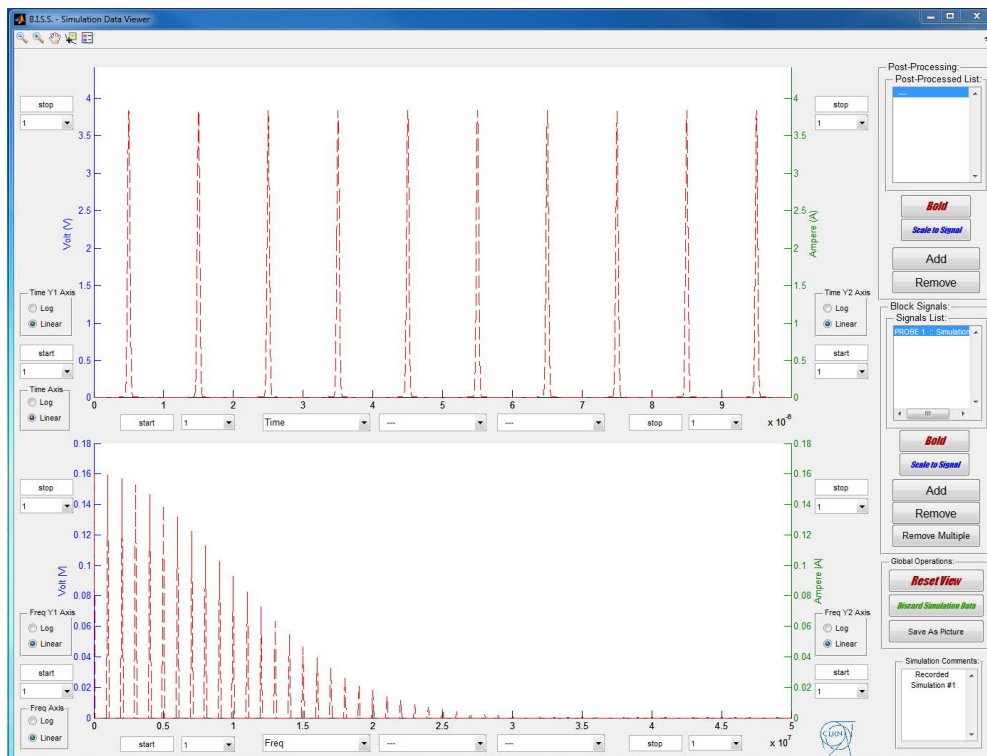

Fig. 3: The Results Viewer. Top plot shows the time evolution of the signal at a probe, while bottom plot shows the frequency content of the signal for the same probe.

5. Manipulating the Graphs in the Results Viewer

5.1 Global Figure Functions

Zooming, obtaining data point values and adding or removing the legend can be performed using the top menu bar in the Results Viewer.

5.2 Axis properties

The axis scale for each graph can be set manually if desired by replacing the "start" or "stop" with a value and selecting the appropriate scaling factor in the adjacent drop-down menu. For example in

Fig. 3 if we wish to look only at frequencies up to 20MHz, then “stop” should be replaced by 20 with 10^6 selected in the adjacent drop-down menu. It is also possible to display the data on a logarithmic scale by selecting the appropriate check-box. Clicking on Reset View will restore the original, auto-scaled display.

5.3 Highlighting Traces

When there are multiple traces present in the Results Viewer it is possible to highlight one of the traces for easier viewing. First select the trace to be highlighted from the Signal List in the Block Signals menu and then click on the Bold button.

5.4 Discarding Traces

To discard simulation results simply select the Discard Simulation Data button in the Global Operations panel of the Results Viewer or the Simulate Actions menu of the workspace. Select the trace or traces (result data) you wish to suppress from the list and click OK.

5.5 Saving Results

In order to save a screenshot of a graph to file, first click on the graph to be saved and then click on the Save as Picture button in the Global Operations panel. Please note that as only one graph is saved at a time it is important to first select the graph to be saved by clicking on it before clicking on the Save as Picture button.

5.6 Post-Processing Results

If you wish to perform simple mathematical operations on the data, or combine signals and then display the results, this is possible using the Add button in the Post-Processed List panel. A ComplexSignalDialogue window will then open to allow mathematical functions to be defined for the new, post-processed trace. This allows two or more traces to be combined via simple addition, subtraction, multiplication or division. It also gives the option of producing a trace of the integrated signal or to find the average, rms, standard deviation, maximum value, minimum value or peak-peak value for any existing traces.

Course on Beam Position Measurement

CAS on Beam Instrumentation 2018

Understanding Beam Position Monitors:

1. Beam Signals in the Time and Frequency Domain

In order to be able to correctly design a pick-up system, it is important to be able to switch between the time and frequency domain. Let's therefore first try to understand what the signal from a Beam would look like if we were able to directly measure it with an ammeter.

1) Let's assume we have a single Gaussian bunch of length (6σ) = 2ns containing 5×10^9 charges. We'll set the Revolution Period to 100ns (revolution frequency of 10MHz) and the number of turns to 1, so that we can see what the signal from a single passage of this bunch looks like.

- Using the Circuit Drawing \Rightarrow Block \Rightarrow Sources \Rightarrow BEAM module produce the time and frequency domain plot for this beam, with the following settings:

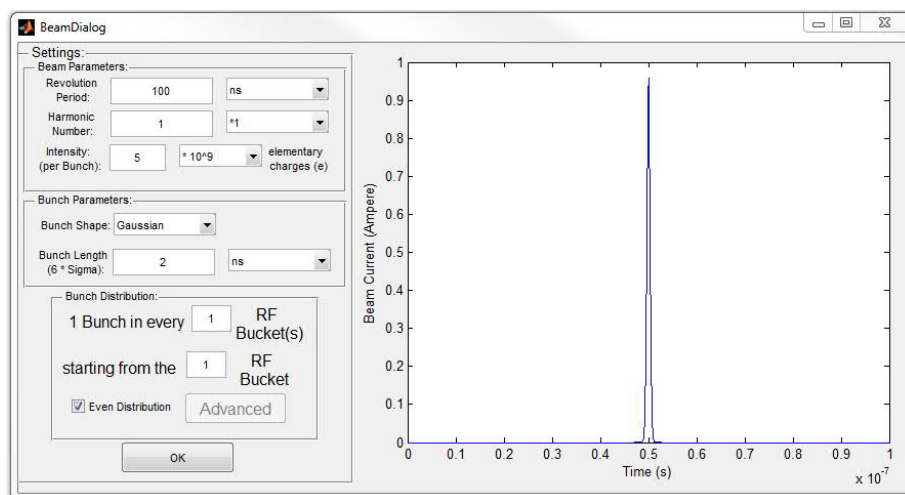
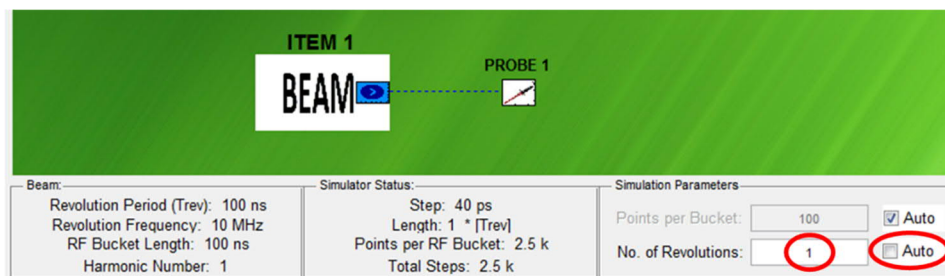

[N.B. Right clicking the mouse on any ITEM in the workspace opens a dialogue window where its "properties" can be found]

- a) What can you say about the frequency content of a Gaussian input signal
- b) What happens to the frequency content of the signal if we increase the bunch length to 4ns or reduce it to 1ns?

Results
a)

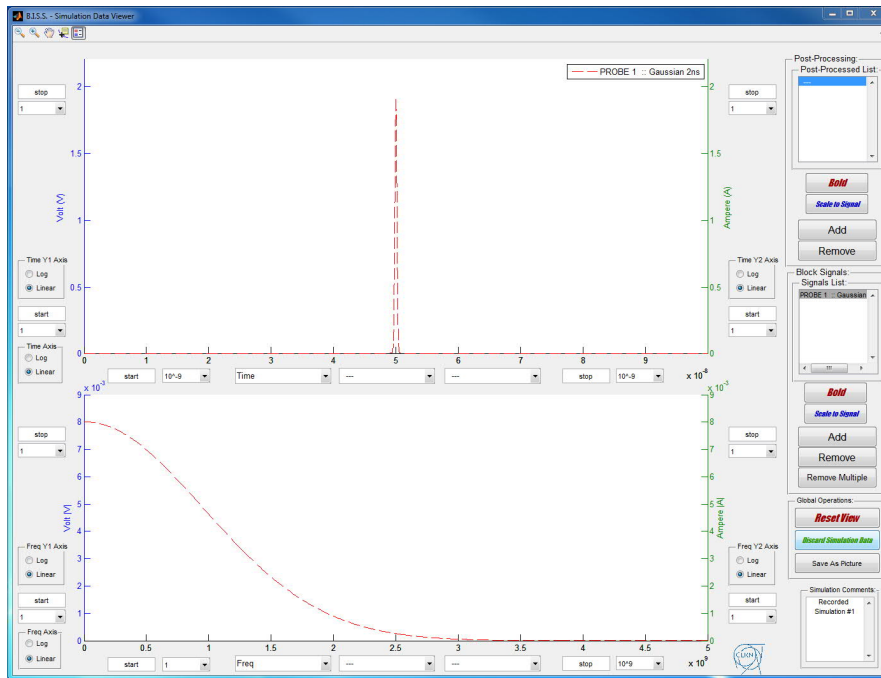

A Gaussian input pulse leads to a Gaussian frequency spectrum.

b)

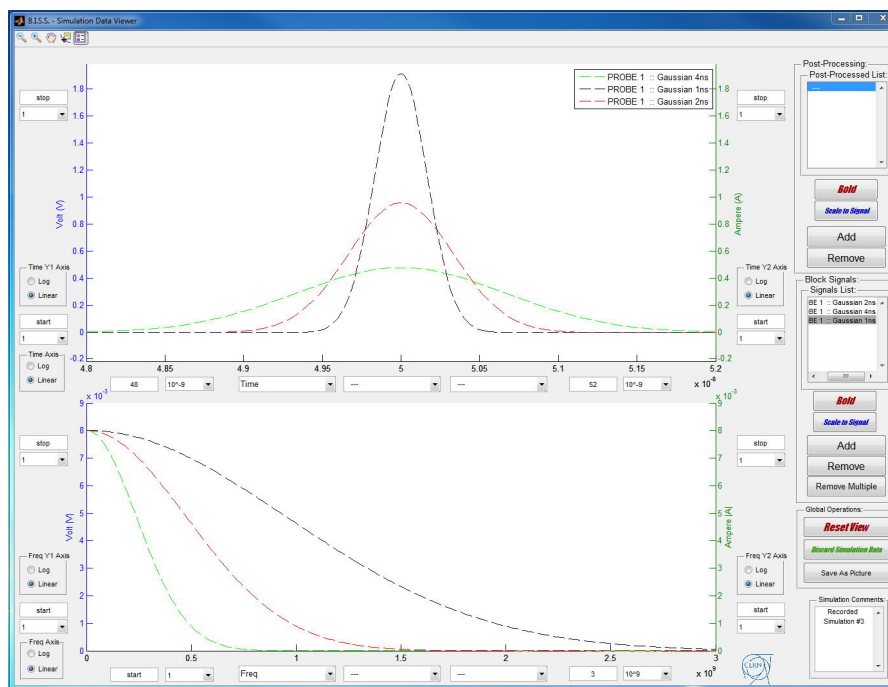

The shorter the pulse the higher the frequency content.

Frequency at half maximum is $\sim \frac{1}{6\sigma(ns)}$ GHz, i.e. 1, 2, 4 ns (6σ) pulses \rightarrow 1, 0.5, 0.25 GHz respectively.

- 2) Although Gaussian approximations are often used in simulating beam parameters, the bunches in a real accelerator are rarely Gaussian in shape. In order to see the effect of non-Gaussian shapes on the beam spectrum:
 - Discard the simulations for 1ns and 4ns, keeping only the results for 2ns (or discard all and re-simulate for a Gaussian bunch of bunch length 2ns).
 - Set the "Bunch Shape" to \cos^2 and "Bunch Length" to 2ns in the BEAM block.
 - Re-simulate.
 - a) What is the main difference? (hint – a log scale in frequency domain can help)
 - b) Can you think of reasons why can it can be important to take the exact shape into account?

Results

a)

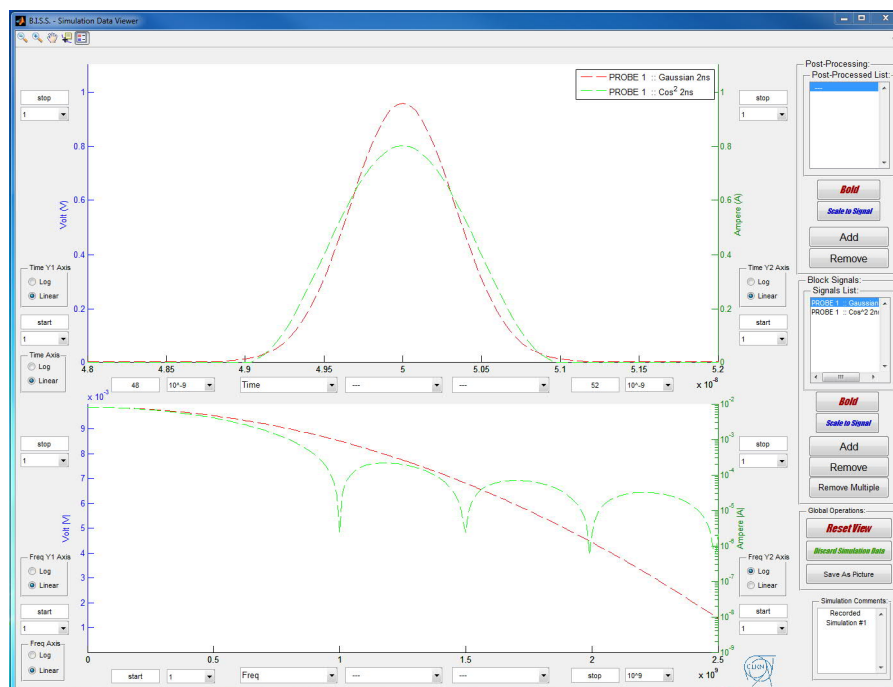

A non-Gaussian bunch shape leads to higher than expected power at higher frequencies.

- b) This is important to take into account when studying the effects of machine impedance, e.g. for instabilities or RF heating. It can also be important to take into account when constructing an electronics chain to work at frequencies higher than the normal Gaussian bunch spectrum, such as for Schottky diagnostics, where this contribution can be significantly higher than the signals to be measured.
- 3) In a circular accelerator or storage ring a bunch will pass by our observation position once every turn. Let's see what happens to the bunch spectrum when have such a circulating bunch.
 - Discard all simulation results.
 - Reproduce the simulation of a single, 2ns, Gaussian bunch for a single turn as in step 1).
 - Now increase the simulation length to 10 turns (Bottom Bar \Rightarrow Simulation Parameters \Rightarrow Simulation Length = 10 turns).

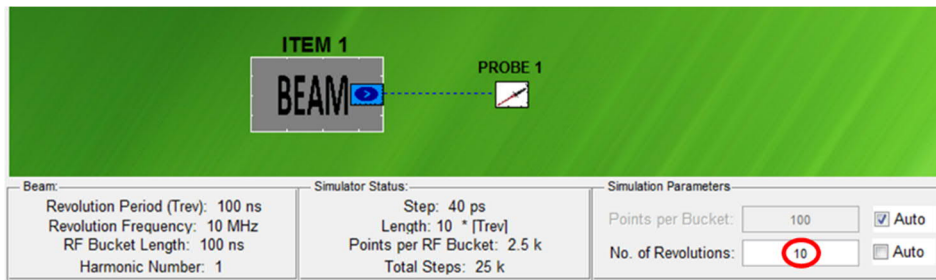

a) What is the result and how is it linked to the revolution period?

Result
a)

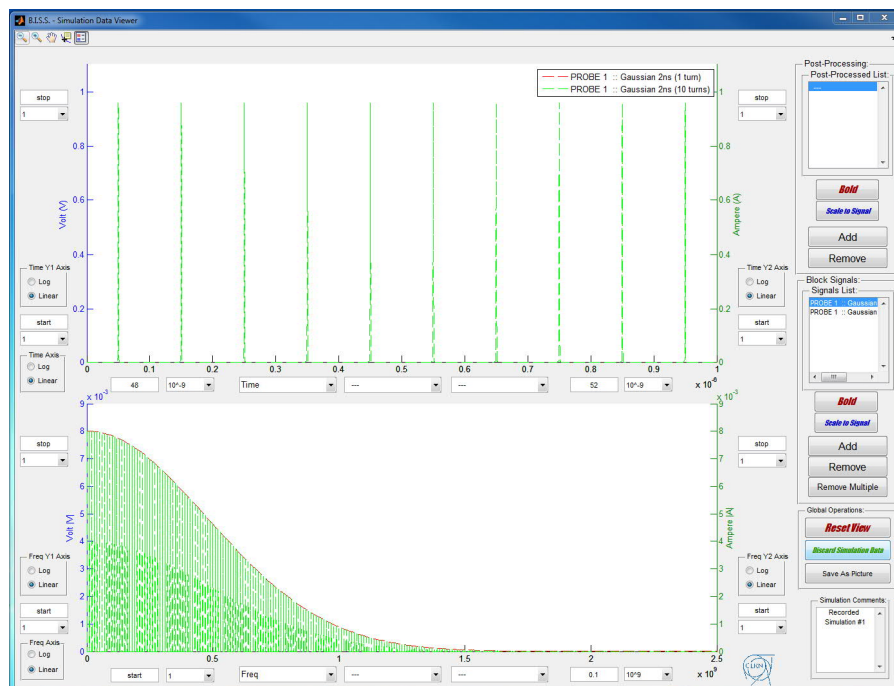

A repetitive signal shows up in the frequency domain as lines at multiples of the repetition frequency. In this case the revolution frequency is 10MHz, so the lines are all spaced by 10MHz. The envelope remains the single bunch spectrum, which still defines up to what frequency there is power in the signal.

- 4) Now let's consider the case of a typical machine where the RF frequency is such as to allow several bunches to be present in the machine at the same time.
- In the BEAM block properties set the harmonic number = 5
 - In the BEAM block properties set the intensity to 1×10^9 charges to keep the total intensity per turn constant.
 - Re-simulate for 10 turns.

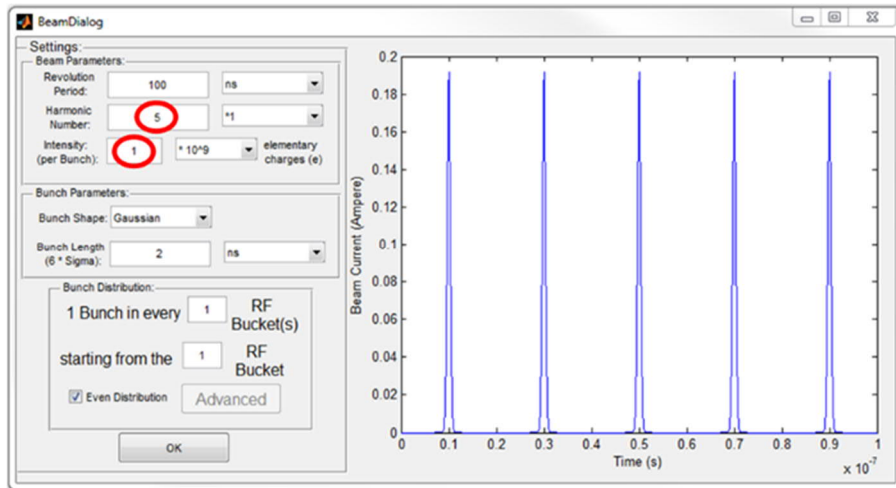

- What is now the corresponding RF frequency?
- What happens to the frequency spectrum?
- Note down a frequency that has:
 - signal associated with it only for single bunch operation.
 - signal associated with it for both single and multi-bunch operation.

Results

a)

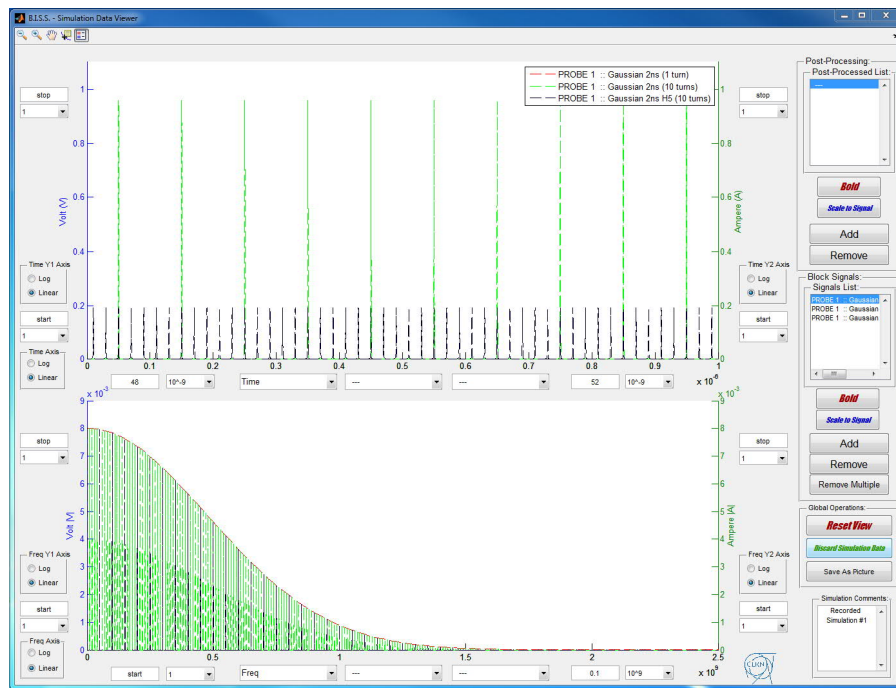

- As we now have 5 bunches coming past our observation point every turn, the repetition frequency has increased from 10MHz to 50MHz.
- The lines in the frequency spectrum are now therefore spaced by 50MHz, i.e. only one line in every 5 compared to the single bunch spectrum now has some signal power associated with it.
- E.g. 10MHz, 20MHz, 30MHz & 40MHz only have power with single bunch operation. 50MHz, 100MHz, 150MHz, ... have power for both single and multi-bunch operation.

2. Beam Position Monitors

The basic quantity required to estimate the signal produced by a BPM is the transfer impedance Z_t . This is a function of frequency and connects the beam current I_{beam} with the useable output voltage U_{signal} , i.e. it tells you what output voltage you will get from your beam position monitor electrode for a given beam current as a function of frequency.

$$U_{\text{signal}}(f) = Z_t(f) \cdot I_{\text{beam}}(f)$$

When designing a BPM system it is important to match the monitor and acquisition system to the beam characteristics – intensity, bunch length and repetition rate. Let us therefore first look at what influences the transfer impedance Z_t of a typical capacitive BPM such as the so-called button pick-up. A button pick-up is usually constructed from 4 equal round disks positioned at the top, bottom, left & right of the vacuum chamber. The transfer impedance at high frequency and the low frequency cut off for such a beam position monitor is given by:

$$Z_{T\infty} = \frac{A}{(2\pi r) \times c \times C_e} \quad f_L = \frac{1}{2\pi R C_e}$$

Where A is the button area, $2\pi r$ the beam pipe circumference, c the speed of light, C_e the button capacitance and R the termination resistance.

The low frequency cut-off is quoted for a difference of -3dB, i.e. the frequency at which the output voltage is a factor 1.4 lower than the maximum (output power a factor 2 lower than maximum). Difference in dB = $20 \times \log \times [\text{Output Voltage/Reference Voltage}]$ or $10 \times \log \times [\text{Output Power/Reference Power}]$ as $\text{Power} \propto (\text{Voltage})^2$.

Now let's see what this means in practice.

- 5) Add the "Beam Position Monitor" Block to the workspace and right click on it, selecting "properties" to get a list of the BPM parameters. To start with we'll consider measuring only in the horizontal plane, so select "Left-Right (Pair)" for the positioning of the electrodes. The other parameters should be as shown below and correspond roughly to an LHC type BPM:

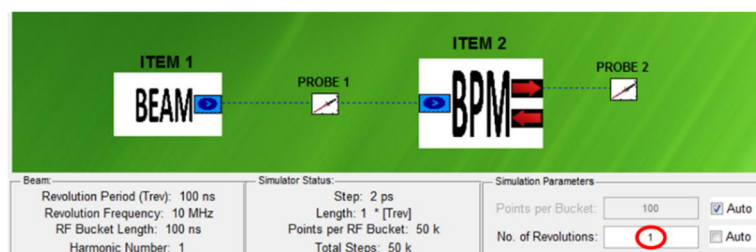

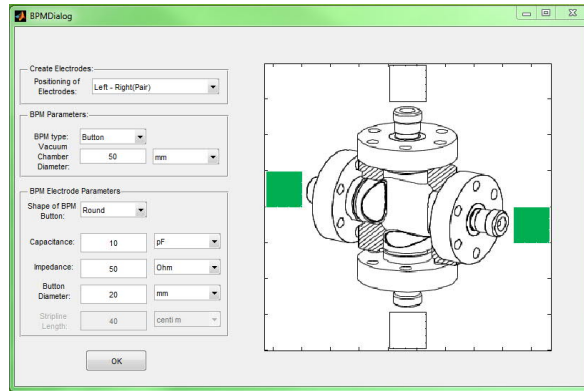

In order to see what the response of a single button is we need to look at the so-called impulse response of the system – i.e. how the button reacts to a very short pulse.
To do this, connect the BEAM module with the following settings:

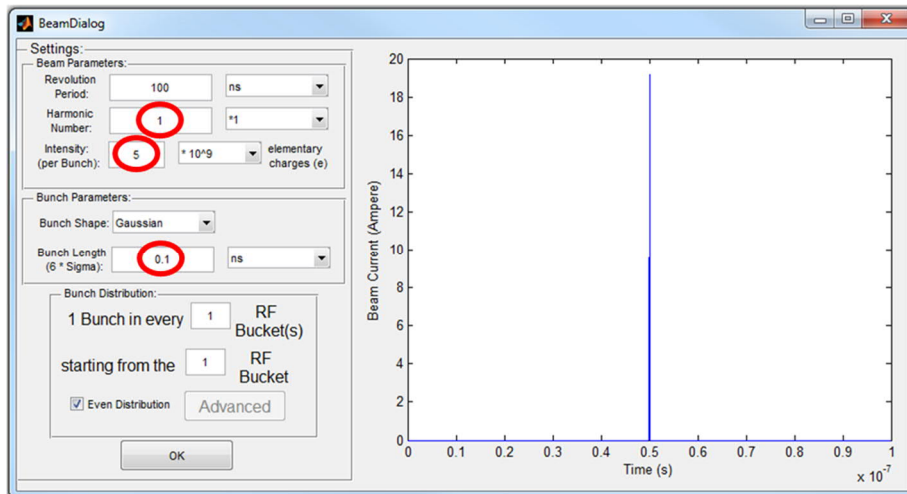

Now put a probe on one of the BPM outputs & simulate the impulse response (you will get an error message to say that the pulse is much shorter than the button and that the simulation may not be accurate – but just click CONTINUE as it's good enough for us!).

The frequency range of interest is up to some 3GHz, so set the maximum of the frequency axis accordingly. You will also need to force the secondary y-axis (in Amperes) to start at zero.

- a) How would you describe the response of a button electrode to an impulse response?
- b) How do the following affect the output in terms of amplitude and signal shape?
 - i. Area of button?
 - ii. Button Capacitance?
 - iii. Termination resistance?

As the beam input can remain the same for all these simulations you can remove Probe 1 if you wish, leaving only the probe after the BPM.

Results

- a) The button electrode acts as a high pass filter. The -3dB cut-off frequency (i.e. factor 1.4 lower

in voltage) is given by $f_L = \frac{1}{2\pi RC_e}$, which in this case is ~300MHz.

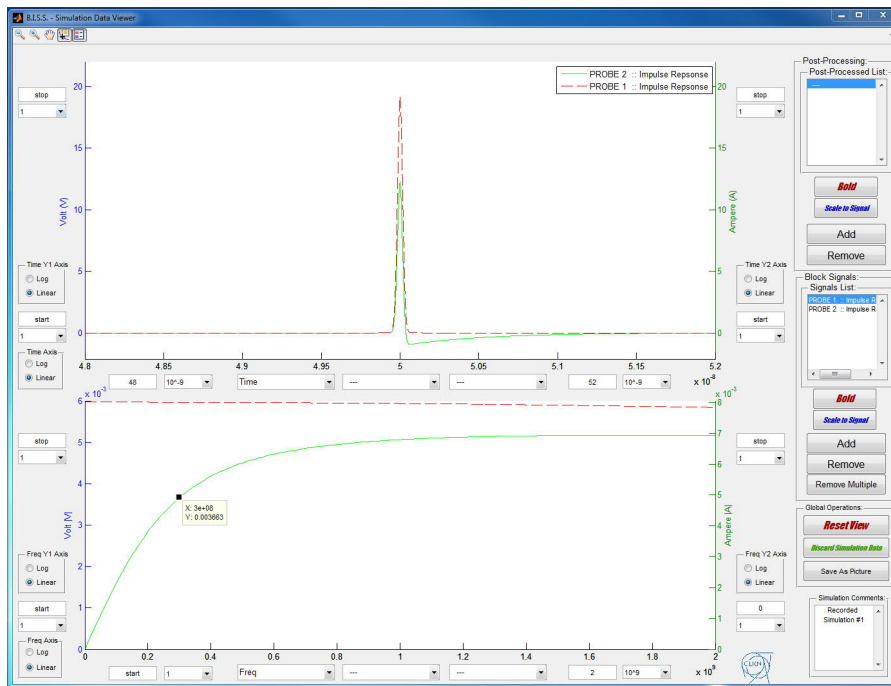

- b) Increasing the area increases the signal amplitude. Increasing the termination resistance lowers the cut-off frequency. Increasing the capacitance lowers the signal amplitude and the cut-off frequency. Although the area does not directly influence the cut-off frequency, in practice increasing the area increases the capacitance, so that the gain in signal amplitude is less than expected, while the cut-off frequency is also lowered.

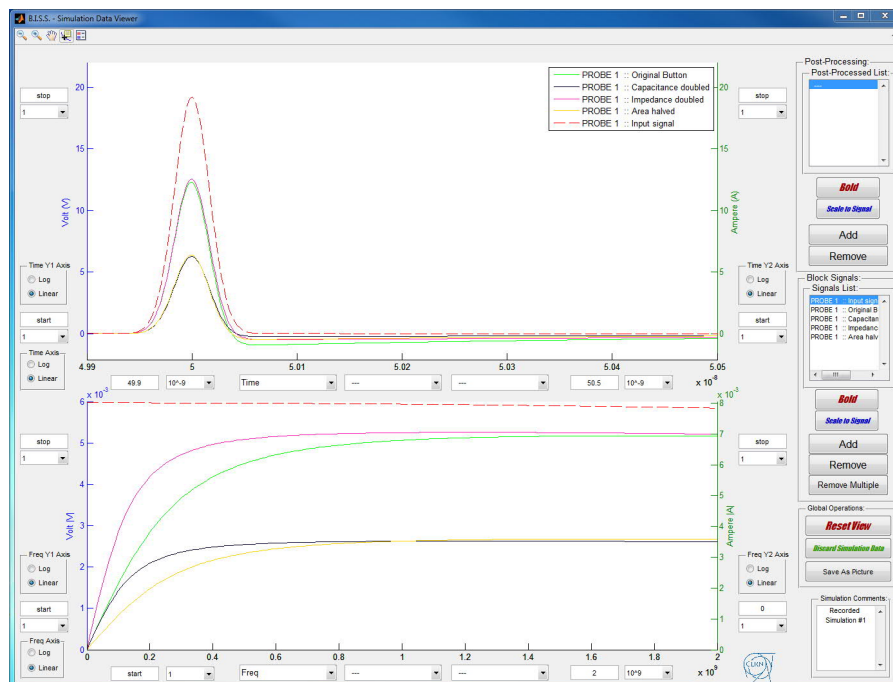

- 6) Instead of a very short pulse, let's now put in a typical LHC type bunch length (~2ns).
- In the BEAM block properties set the bunch length to 2ns
 - Re-simulate (remember to put back a probe after the BEAM block if not already present)
- a) Compare this with the impulse response of question 5. What do you notice?

Result
a)

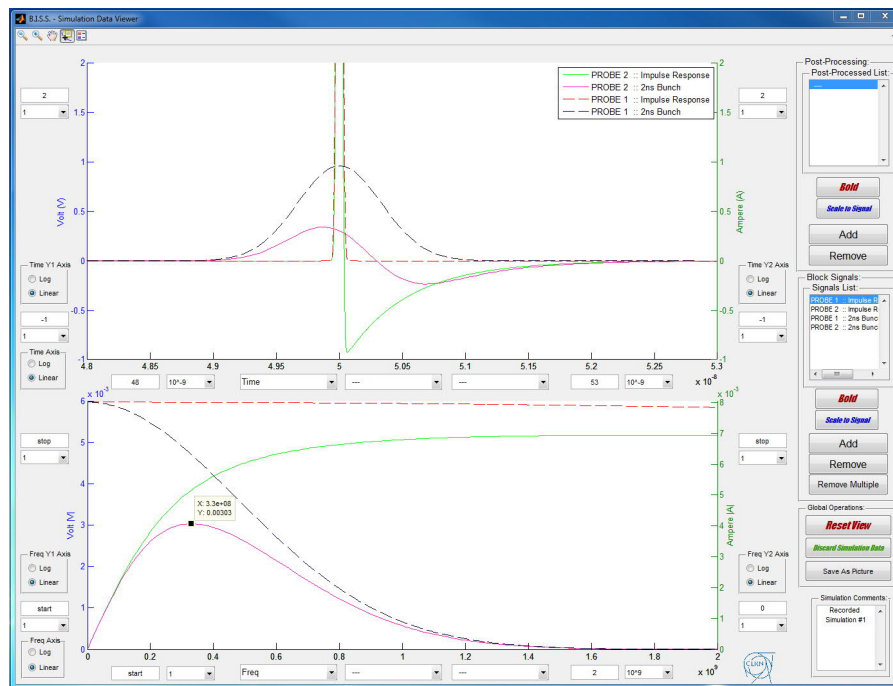

For a 2ns bunch the high frequency content is defined by the bunch spectrum rather than the button, while the low frequency content is defined by the button. The result is a convolution (multiplication in frequency domain) of the bunch spectrum and the button spectrum. In this case the highest signal is obtained at a frequency of 330MHz.

- 7) Using the knowledge gained in question 6, construct a button electrode with impedance 50Ω capable of providing 100mV peak signal at its output for a 2ns bunch of 5×10^9 charges.
- What are the parameters of your button BPM?
 - At which frequency does it have the highest output signal?

Result
a) E.g.

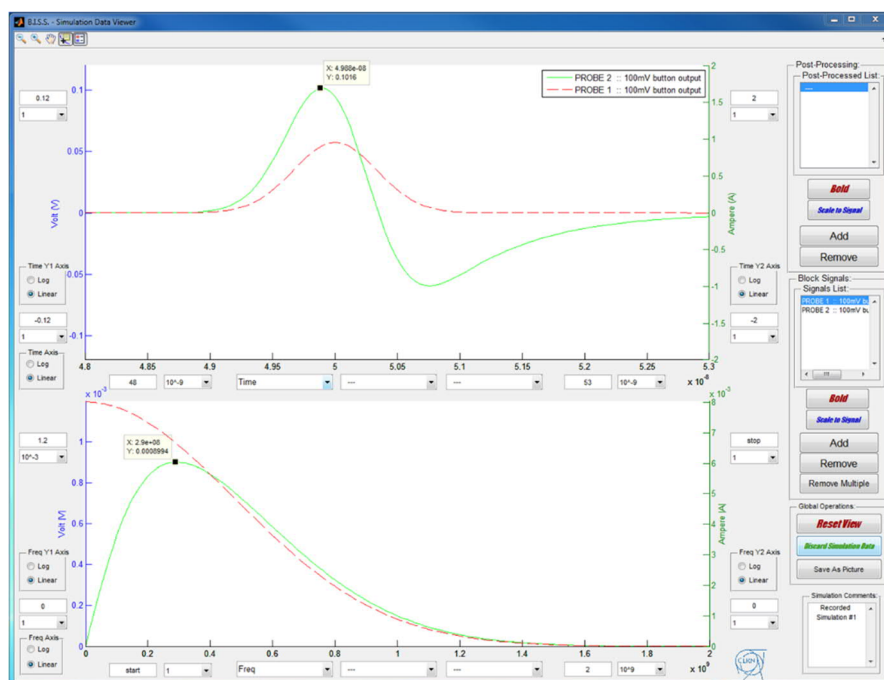
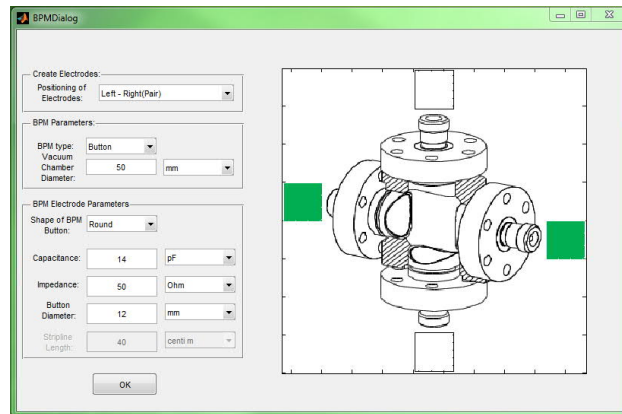

There are many possible combinations. In this example a 14pF button capacitance and a 12mm button diameter is used. The peak output signal is obtained at 290MHz.

The easiest way to obtain a given output voltage is to match capacitance and area. The termination resistance is typically forced to be 50Ω to allow connection to standard coaxial cables.

Impedance transformation is possible to lower the cut-off frequency. It must be done before the cable going to the BPM electronics. If a passive RF transformer is used, the transformation is done at the expense of the signal amplitude. If an amplifier with high input impedance is used, then the cost is having electronics in a potentially radioactive environment.

- 8) To calculate the position using a real BPM it is necessary to compare the difference in electrode signals from opposite electrodes. In the simulation tool the beam position is controlled by the "POSITION" block.

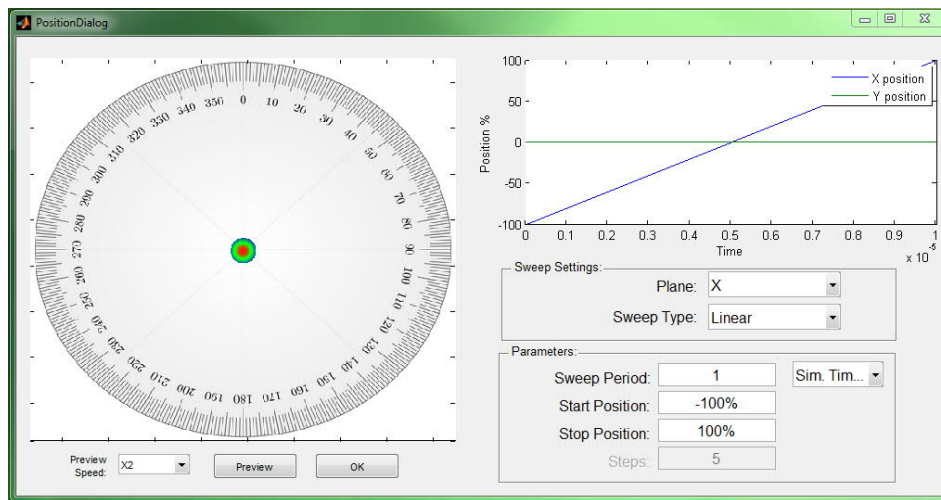

In the example above the properties of the position block are adjusted so as to sweep the position linearly ("Linear" Sweep Type) in the horizontal plane ("X" Plane) from left to right ("Start Position" -100%, "Stop Position" 100%) over the whole aperture. The time it takes to do this is set to be the "Sim. TimeSpan", i.e. the whole of the simulation time. For a simulation of 100 turns this then gives a position change of 2% of the aperture per turn.

Construct a 50mm beam position monitor based on a 14pF, 50Ω, 12mm diameter button electrode. Insert the "POSITION" block in between the "BEAM" and "BPM" blocks. Probe the two outputs (left and right electrode) of the BPM.

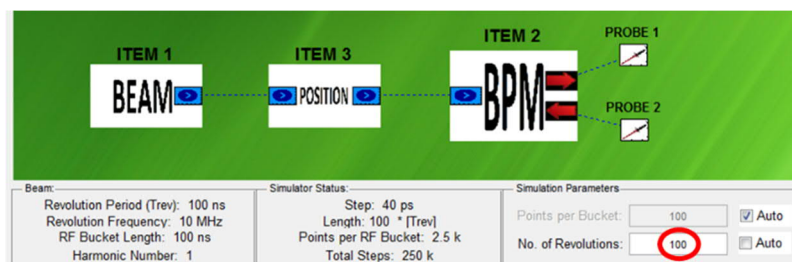

Use a beam with a 100MHz RF structure comprised of 2ns Gaussian bunches and simulate over 100 turns.

- What harmonic number needs to be chosen in the "BEAM" block to generate such a beam?
- What do you notice about the output electrode signals?

Results

- The harmonic number needs to be set to 10 to obtain a 100MHz RF structure on the beam with a 100ns revolution frequency.

b)

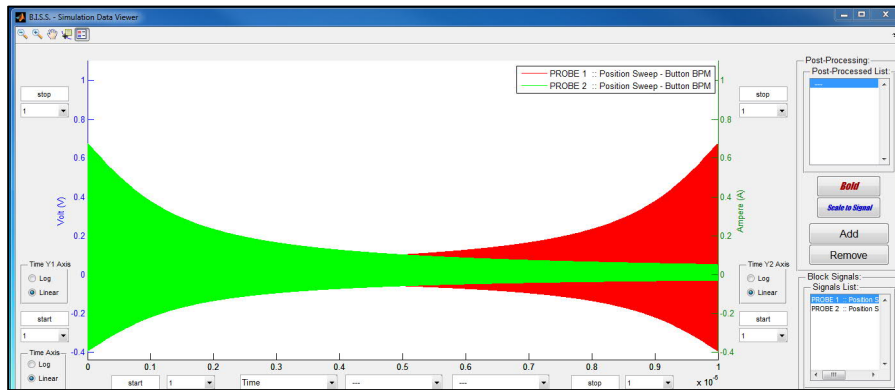

For a button BPM the amplitude of the output increases as the beam approaches the electrode in a non-linear fashion. In this case for a beam in the centre of the vacuum chamber the electrode signal is 100mV, while the signal near the button and on the opposite side is 700mV and 50mV respectively.

- 9) In order to calculate the horizontal position we need to obtain the difference between the left and right electrode amplitudes. This can be done using an electronic device called a hybrid. A hybrid can be an active or passive electronic device and simply has the role of adding and subtracting the input signals over a given frequency range. In the simulation the hybrid works over the whole frequency range and simply provides a sum (Σ) and difference (Δ) output of the two input signals.

Add a "HYBRID" from the analogue blocks (Common Mode Rejection Ratio = 100%, i.e. the difference output is perfect with no leakage from the sum output) to the previous circuit as shown below, probing only the difference (Δ) output, and re-simulate.

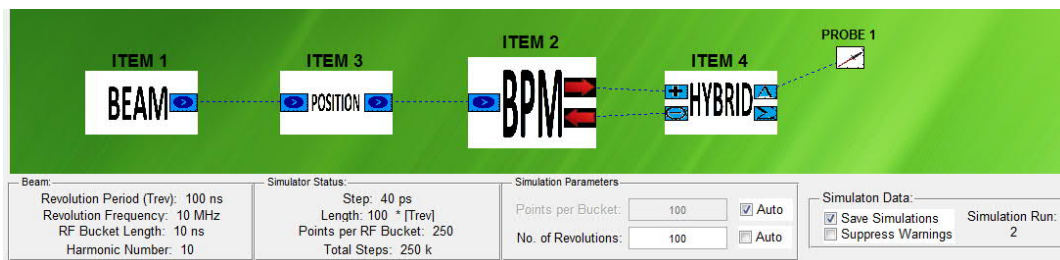

Now increase the bunch intensity by a factor of two, re-simulate and compare to the signal from half the intensity.

- a) What do you notice about the difference signal?

Result

- a) The difference signal scales with the intensity.

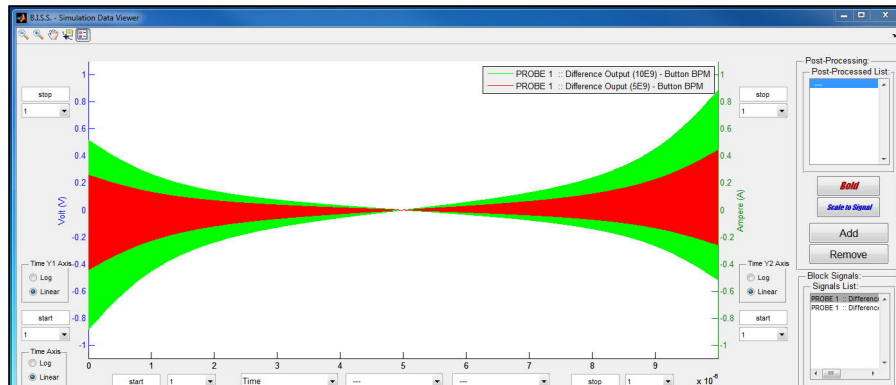

- 10) In order to use the difference signal to find a position it is necessary to NORMALISE the signal, i.e. to make it intensity independent. This is achieved by dividing the difference (Δ) output by the sum (Σ) output.

Insert a division "/" block from the mathematical operations section, re-set the intensity to 5×10^9 and simulate. Double the bunch intensity, re-simulate and compare the output signal from the two different intensities.

- a) What do you now notice about the difference signal?
b) Work out what position a Normalised output of 0.4 corresponds to?

Results

- a) The difference signal is now intensity independent with both outputs lying perfectly one on top of the other. The Normalised Position varies between -1 and 1.

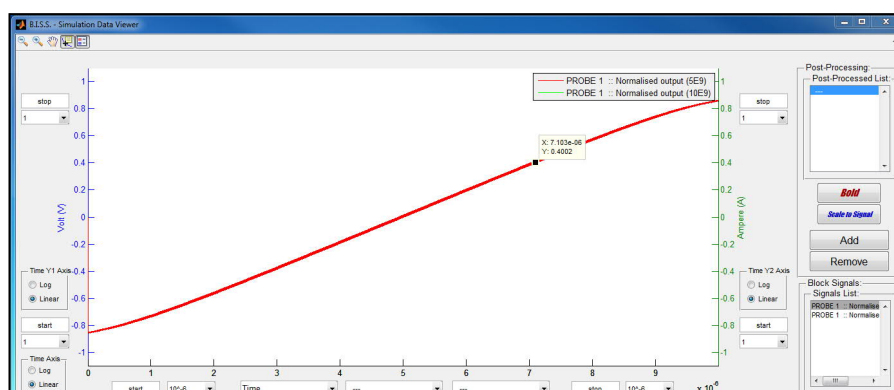

- b) The position is swept from -25mm to 25mm in 10 microseconds. This corresponds to 5mm per microsecond. In the example a Normalised output of 0.4 corresponds to 7.1 microseconds, i.e. a position of $-25 + 7.1 \times 5 = 10.5$ mm.

Beam Position Acquisition Systems:

1. Analogue to Digital Conversion:

Now that we know how to obtain an intensity independent position reading the next stage is to turn this into something that can be displayed in the control room. As it is difficult to perform the signal division block with analogue electronics the usual way of doing this is to digitise the difference (Δ) and sum (Σ) outputs from the hybrid and then perform the division in the digital domain. This can be done directly in a computer or using digital processing electronics such as a Field Programmable Gate Array (FPGA) or dedicated Digital Signal Processing (DSP) chip.

The "Analogue to Digital Converter" (ADC) from the Special Blocks has the following properties:

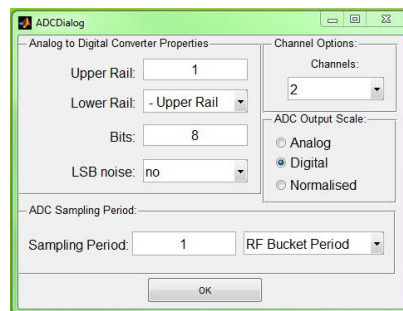

- The upper & lower rail voltages define the input range that the ADC can handle, in the example shown $\pm 1V$.
- The number of bits defines the granularity with which this input range is quantised, typically ranging from 8 bits for systems sampling at > 1 GSamples/s to 24 bits for systems sampling at < 200 kSamples/s. In the example shown an 8 bit ADC has been defined, which means that the $\pm 1V$ input range is split into 2^8 (=256) digital levels.
- The number of bits of noise that the ADC has. This is typically a few bits, but in the tool is limited to the LEAST SIGNIFICANT BIT (LSB), and can be switched ON/OFF.
- The number of channels, which allows the same block to be used to digitise multiple inputs.
- The output scale
 - Analog in Volts
 - Digital in bits (from $-\frac{1}{2} \times 2^{\text{No. of bits}}$ to $+\frac{1}{2} \times 2^{\text{No. of bits}}$)
 - Normalised from -1 to 1
- The time at which the ADC samples the input waveform. In the example shown the waveform is sampled once every RF bucket.

11) Add the following "Analogue to Digital Converter" (ADC) from the Special Blocks after the hybrid.

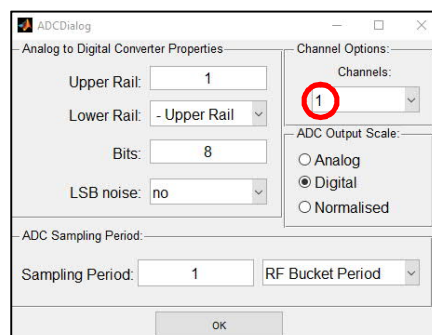

Let's initially look at only the sum (Σ) output. Simulate the system for a bunch intensity of 5×10^9 .

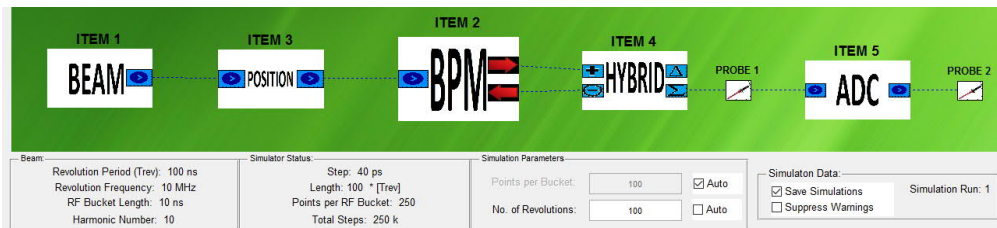

- To what voltage difference does the least significant bit of the ADC correspond (i.e. an increment of 1 when representing the ADC output in decimal)?
- At what bunch intensity does the circuit saturate for large position offsets?

Now let's look at measuring position. To obtain the position we again need to normalise the signal to make it independent of intensity.

Replace the one channel ADC with a 2 channel ADC digitising both the sum (Σ) and difference (Δ) signals after the hybrid. Insert a division "/" block from the mathematical operations section, this time using the digitised data at the output of the ADC. You can also insert another "/" block just after the hybrid to allow a comparison of the analogue and digital output data.

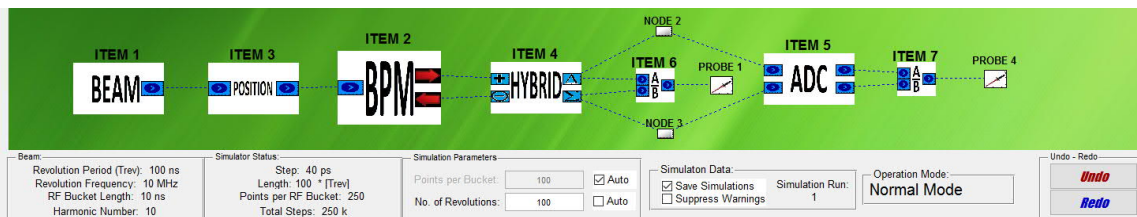

- Looking at the difference signal at the centre of the beampipe (where the sum signal remains constant) determine the maximum resolution of this system.
- How many bits do we need to have a resolution of 190 micrometres for a maximum bunch intensity of 5×10^9 ?

Results

- The least significant bit corresponds to $2V (\pm 1V) / 256 = 0.008V$ (8 mV). i.e. each time the voltage increases by 8 mV the decimal output of the ADC increases by 1.
- The sum signal will saturate at large position offsets for intensities over 1×10^{10} .

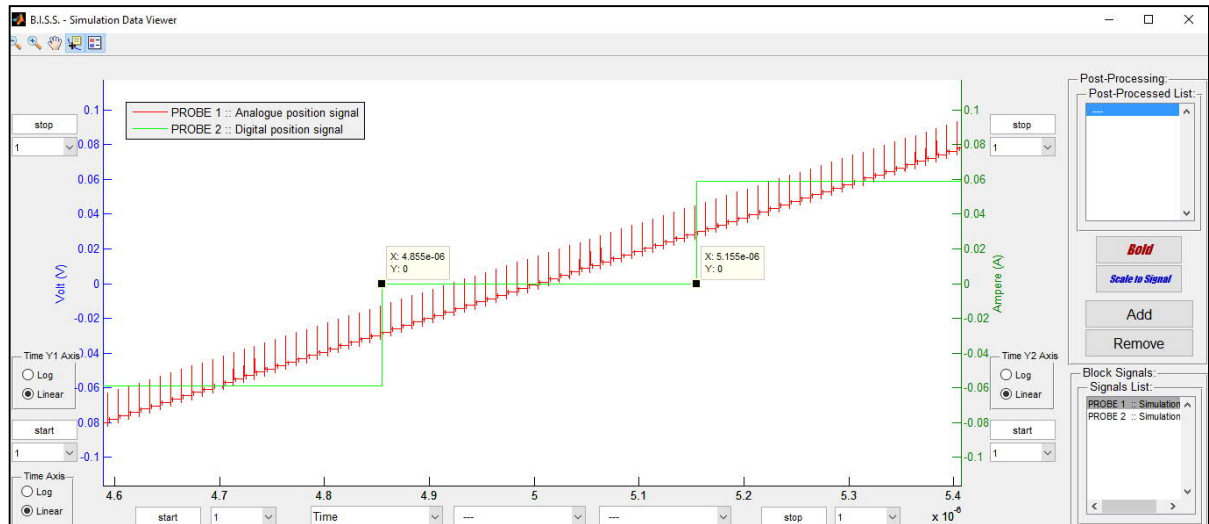

- The maximum resolution of the system corresponds to the least significant bit. Looking at the centre, the time taken to flip by the least significant bit is $5.155 - 4.855 = 0.3$ microseconds. Knowing that the position sweep is at 5mm per microsecond, the maximum resolution is $0.3 \times 5 = 1.5$ mm.
- To reach a resolution of 190 microns we need the least significant bit to represent 0.190 mm instead of 1.5mm, implying 8 times more granularity. This means that the ADC required needs 3 more bits ($2^3 = 8$). An 11-bit ADC (original $2^8 = 256 \Rightarrow 2^{11} = 2048$) is therefore required.

2. Homodyne and Heterodyne receivers

Heterodyning is a radio signal processing technique invented in 1901 by Canadian inventor-engineer Reginald Fessenden that creates new frequencies by combining or mixing two frequencies. Heterodyning is used to shift one frequency range into another, new one, and is also involved in the processes of modulation and demodulation. The two frequencies are combined in a nonlinear signal-processing device such as a vacuum tube, transistor, or diode, usually called a mixer.

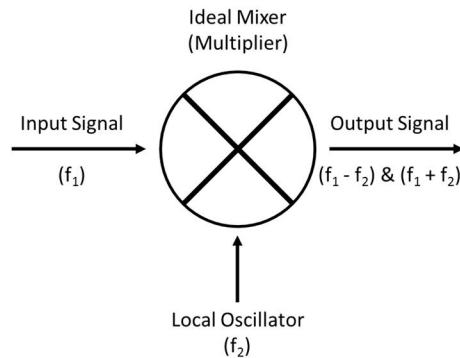

In the most common application, two signals at frequencies f_1 and f_2 are mixed, creating two new signals, one at the sum $f_1 + f_2$ of the two frequencies, and the other at the difference $f_1 - f_2$. These new frequencies are called heterodynes. Typically only one of the new frequencies is desired, and the other signal is filtered out of the output of the mixer.

In a homodyne the input frequency (f_1) is itself used to generate the local oscillator frequency (f_2). The resulting frequencies become DC and $2f_1$, where the second harmonic is again filtered out, to leave only the DC component. In this way, a frequency component is converted into a DC signal level that is directly proportional to the original amplitude of the signal.

Such mixing techniques are often employed in beam position acquisition systems to move the frequency range of interest (i.e. the signal frequency) from that determined by the BEAM/BPM combination (often high or very high frequency) to a lower frequency which is easier to handle digitally, with lower frequency ADCs having more bits, and therefore better resolution.

Homodyne Circuits for Continuous Signals

Let's look at how to construct a homodyne detection system for a circulating (continuous) beam.

12) Construct the circuit as shown below:



- The "BEAM" should have the following parameters:
 - Revolution period 100ns
 - Harmonic number 10
 - Intensity 1×10^{12} charges
 - Cos^2 distribution
 - Bunch length 10ns with 1 bunch in every RF bucket
- The "POSITION" should be set to "CONSTANT" and equal to zero
- The "BPM" can be the same BPM constructed in Q7 of Part 1

Run the simulation and observe the frequency and time domain signals.

a) What do you observe about the frequency content for this particular "BEAM"?

To create a homodyne circuit we need to generate a local oscillator (f_2) that is an intensity independent signal (i.e. constant amplitude signal) with the same frequency as the input signal (f_1). This can be done using a limiting amplifier to produce a square wave from the input signal.

Add an amplifier stage and try to obtain such a signal.

b) What are the parameters of your amplifier?

Now mix the two signals together using a multiplication "*" block from the mathematical operations section. This will represent our homodyne mixer.

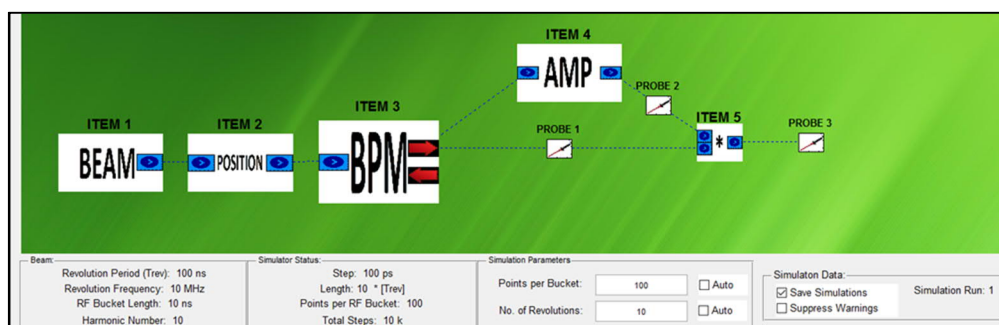

Run the simulation again and observe the frequency and time domain signals (zoom in between 0-100ns for the time domain).

c) What do you observe about the frequency content before and after the mixer (multiplier)?

In the end, we only want to retain the DC signal. Insert a filter block and adjust the parameters such that a steady state output signal is obtained by the mid-point of the simulation (i.e. 500ns).

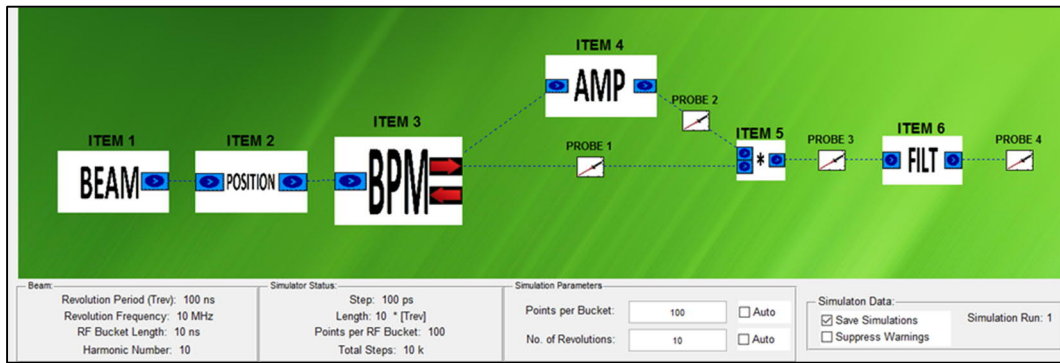

- d) What does the response time of the filter depend on?
- e) What is the ratio of your DC component to the first harmonic?
- f) How can this be further increased without impacting the overall response time?

Results

a) The spectral content of this particular beam only has one frequency line at 100MHz

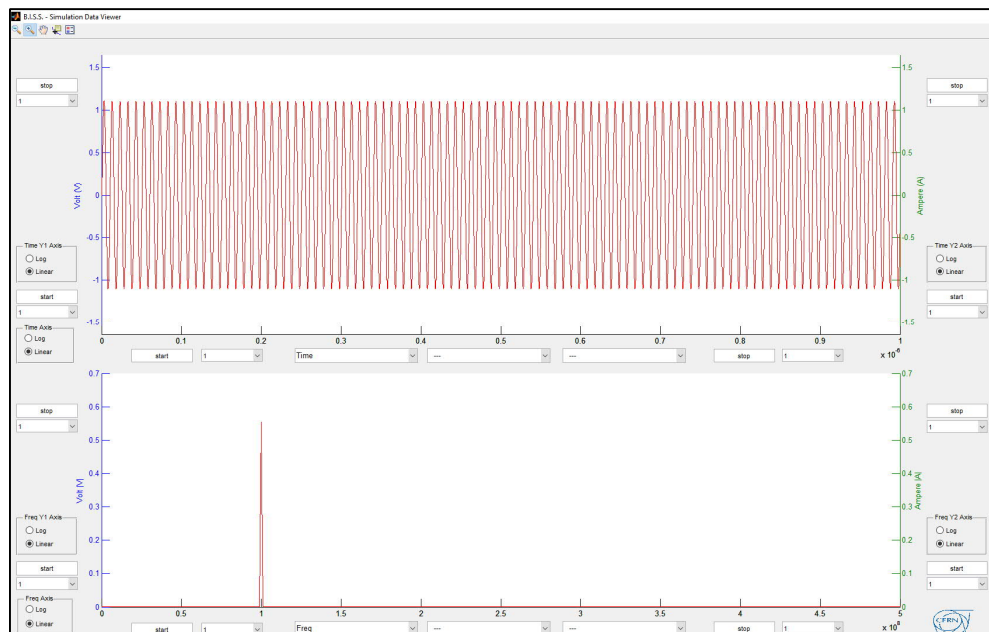

b) If done correctly the amplifier output will be a square wave

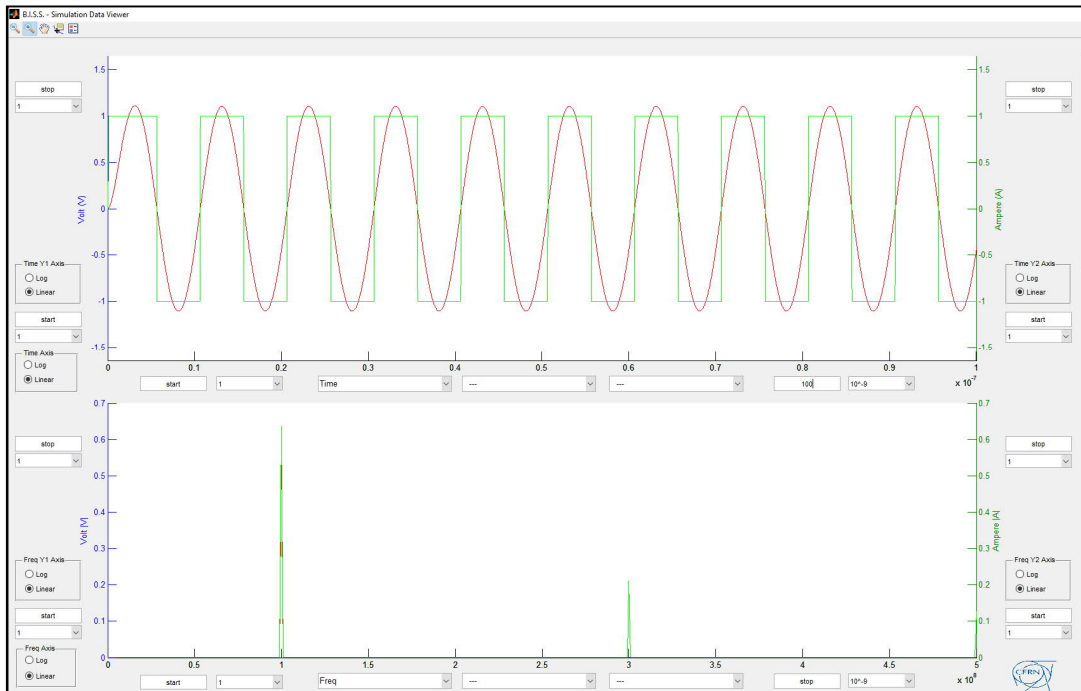

c) The signal is "rectified" so that the frequency content after the multiplier contains the sum ($f_{\text{BEAM}} + f_{\text{AMP}} = 200\text{MHz}$) and difference ($f_{\text{BEAM}} - f_{\text{AMP}} = 0\text{MHz}$, i.e. DC).

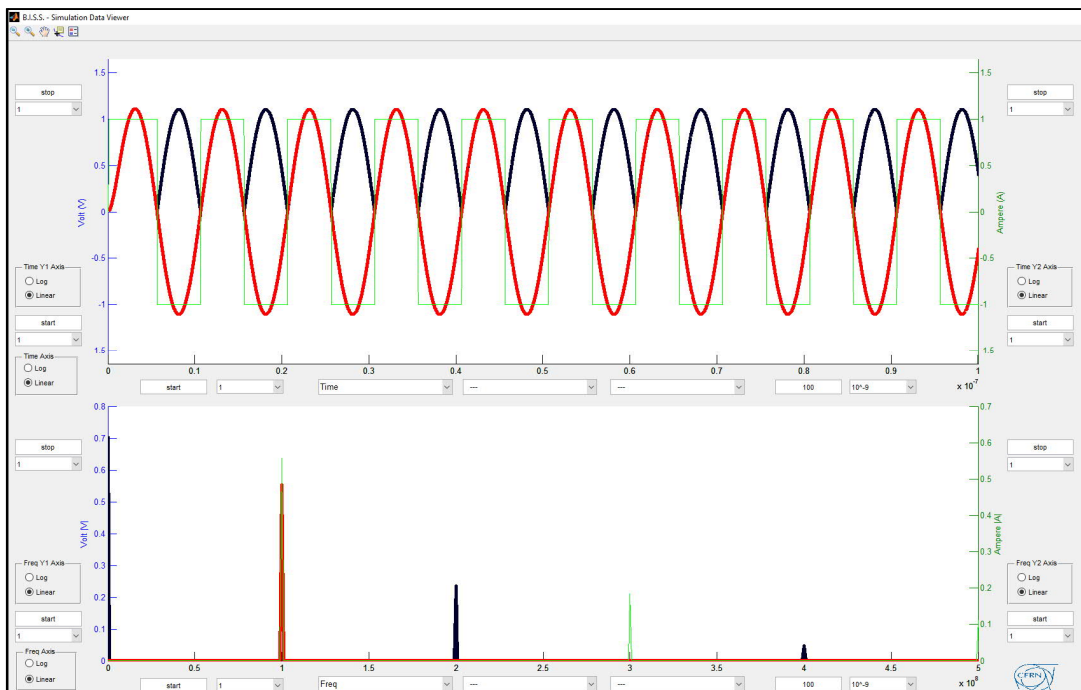

- d) The response time of the output depends on the cut-off frequency of the filter. A simple 1MHz lowpass gives the following result.

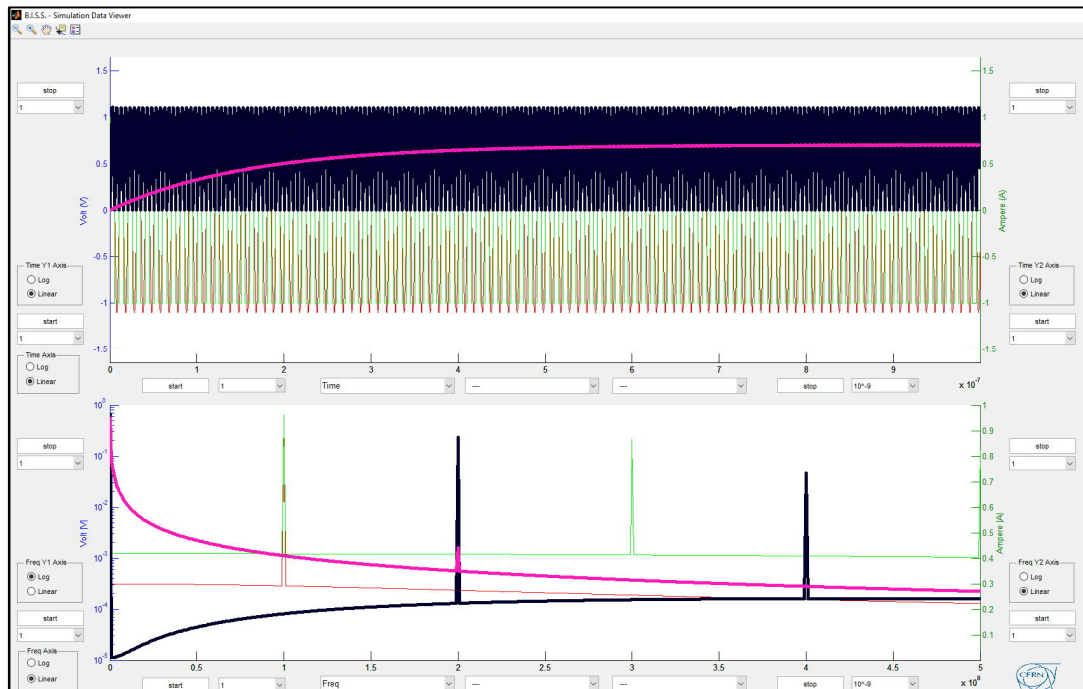

- e) In this case there is a factor of 60 between the DC component and the 2nd harmonic at 2MHz.
- f) A higher order filter can be used, but to give the same response time the cut-off frequency also needs to be changes. A comparison of the first order response of above with that for a 2^{ns} order RC low-pass with 2MHz cut-off can be seen below.

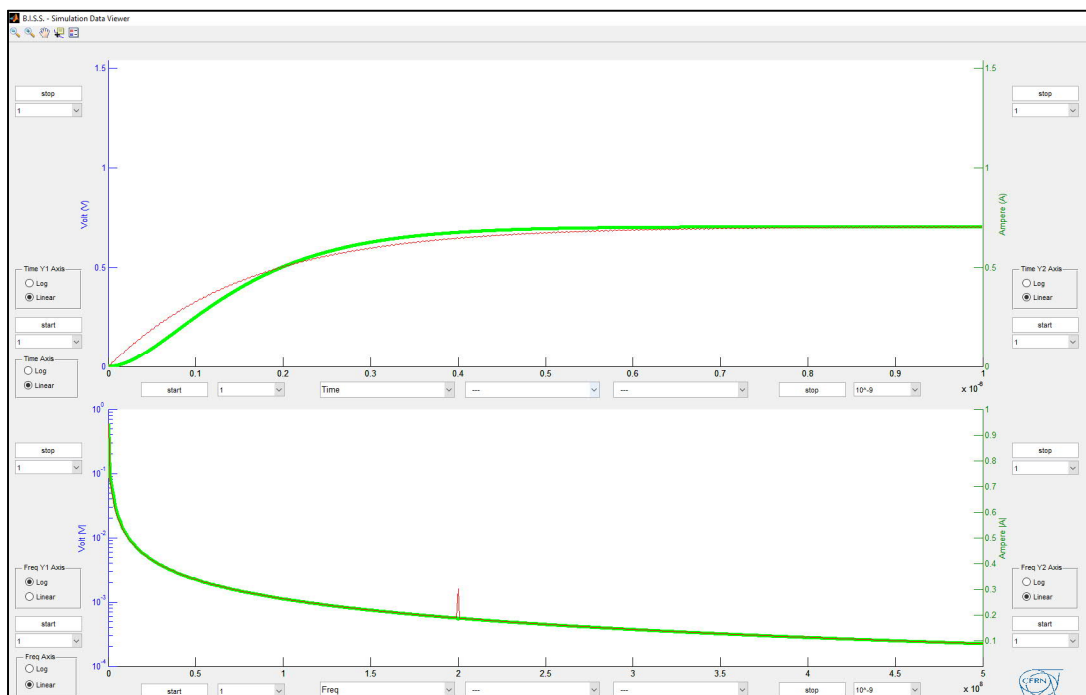

Homodyne Circuits for Pulsed Signals

Homodyne circuits, such as the one above, can also be used for pulsed signals as long as the pulse length allows a steady state signal to be reached (e.g. measurement of the position in a linac or transfer line). When the pulse is very short, other tactics have to be employed. In this case the trick is to use the beam to excite a bandpass filter that rings for long enough for the homodyne circuitry to work. Let's now look at how to construct a homodyne detection system for a short, single pass bunch.

13) Construct the circuit as shown below:

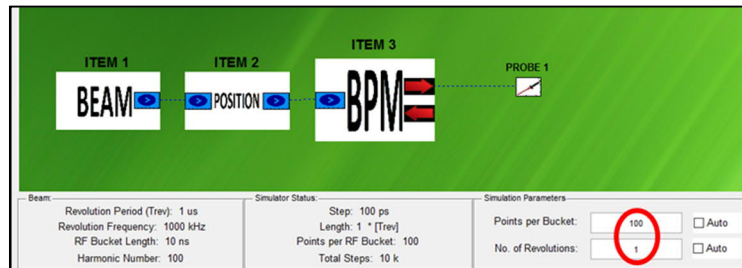

- The "BEAM" should have the following parameters (and note that the "No. of Revolutions:" on the main tab should be set to 1:
 - i. Revolution period 1000ns
 - ii. Harmonic number 100
 - iii. Intensity 1×10^{12} charges
 - iv. Cos^2 distribution
 - v. Bunch length 10ns with 1 bunch every 100 RF bucket

This simulates a single passage for a single bunch over the same time period ($1 \mu\text{s}$) as in the continuous case

- The "POSITION" should be set to "CONSTANT" and equal to zero
- The "BPM" can be the same BPM constructed in Q7 of Part 1

Now add a filter block after the BPM signal. Try to find bandpass filter settings that result in the highest amplitude for a ring time that is at least half the simulation time of $1 \mu\text{s}$.

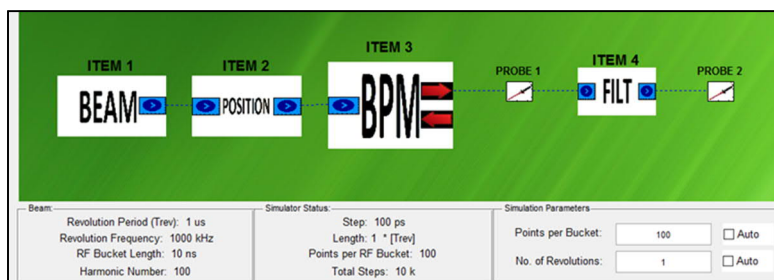

a) What do you notice about the relationship between frequency, amplitude and ring time?

Adapt the signals such that you can re-use the homodyne stage developed for the continuous beam to also process the pulsed beam signal.

b) What is the important element to add?

Results

- a) Maximum amplitude obtained where convolution of BPM response and beam frequency content is a maximum (80MHz in this case). The narrower the filter the more it rings but the lower the amplitude. A first order RC filter of 78-82MHz gives the following response to a single bunch:

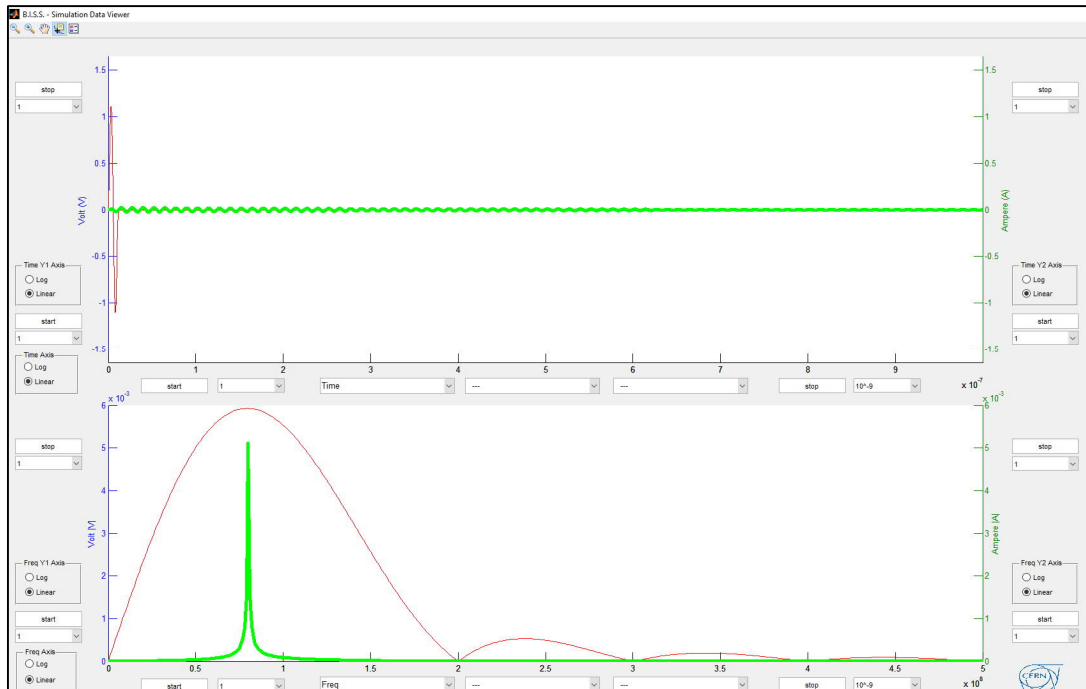

Zoom-in on the amplitude:

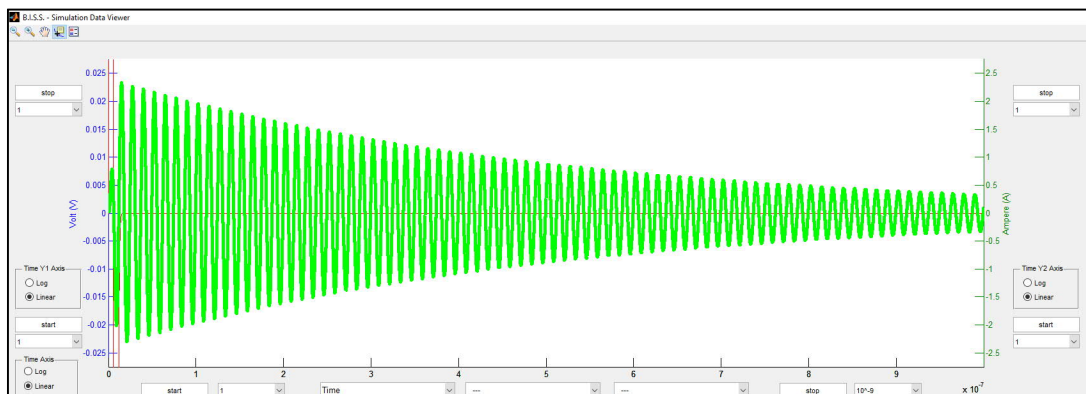

b) An amplifier stage needs to be added after the bandpass filter to recover the signal level before further processing.

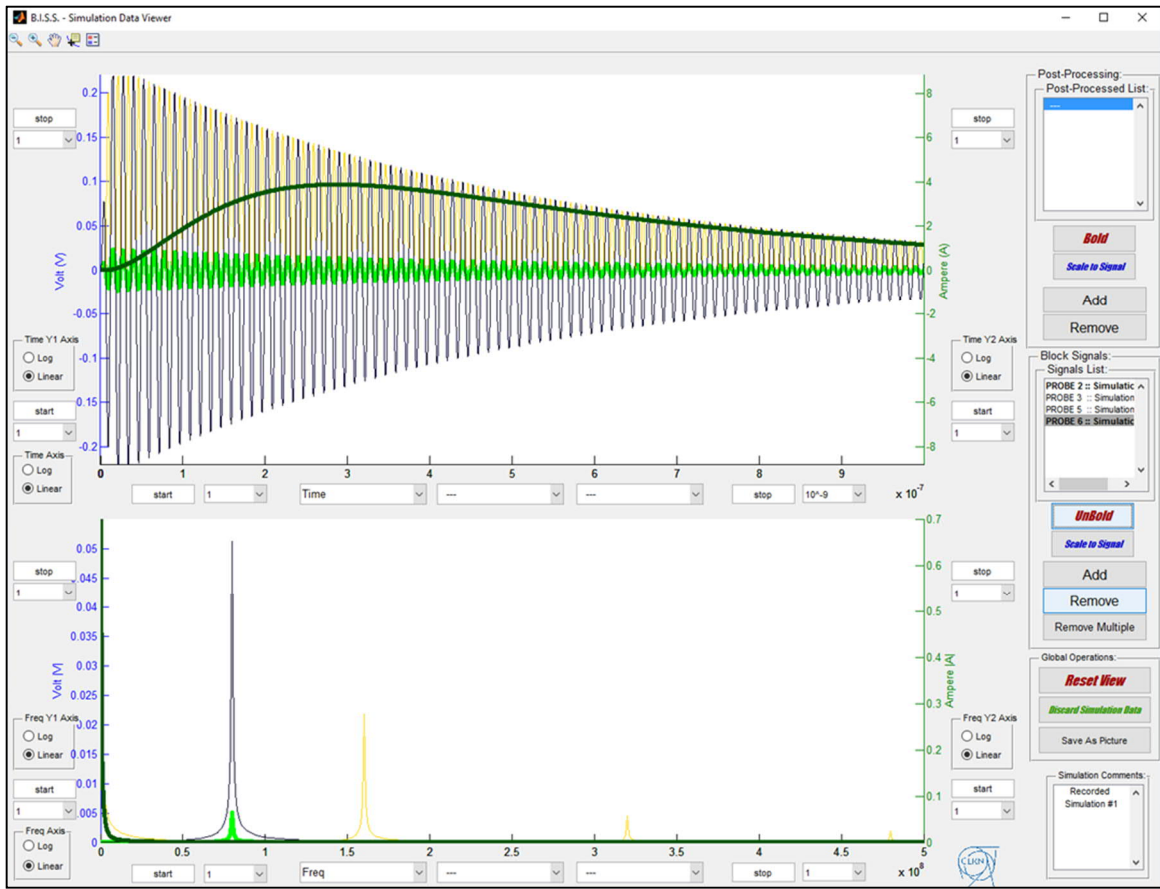
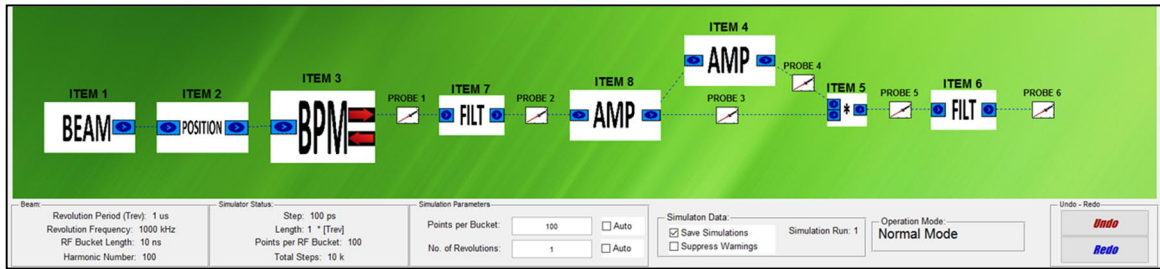

14) As a final task, select one of the two homodyne systems investigated and build a complete beam position system based on this technique with the following specifications:

- Dynamic range: bunch intensity from 1×10^{10} to 1×10^{12} charges
- Resolution: better than $150 \mu\text{m}$ for a centred beam

Result

e.g.

