



Instabilities Part II: Longitudinal wake fields – impact on machine elements and beam dynamics

Giovanni Rumolo and Kevin Li

- We have learned about the concept of **particle distributions** as well as some **peculiarities of multiparticle dynamics** in accelerators, decoherence, filamentation.
- We will learn the basic **concept of wake fields** and how these can be characterized as a **collective effect** in that they depend on the particle distribution.
- We will have a basic understanding of multiparticle systems and wakefields and are now ready to look at the **impact of these** in the longitudinal and transverse planes.

Part 2: Multiparticle dynamics with wake fields – impact on machine elements and longitudinal beam dynamics

- General introduction to wake fields
- Longitudinal wake fields and the longitudinal wake function
- Energy loss – beam induced heating and stable phase shift
- Potential well distortion, bunch lengthening and microwave instability

- We have learned about the concept of **particle distributions** as well as some **peculiarities of multiparticle dynamics** in accelerators, decoherence, filamentation.
- We will learn the basic **concept of wake fields** and how these can be characterized as a **collective effect** in that they depend on the particle distribution.
- We will have a basic understanding of multiparticle systems and wakefields and are now ready to look at the **impact of these** in the longitudinal and transverse planes.

Part 2: Multiparticle dynamics with wake fields – impact on machine elements and longitudinal beam dynamics

- General introduction to wake fields
- Longitudinal wake fields and the longitudinal wake function
- Energy loss – beam induced heating and stable phase shift
- Potential well distortion, bunch lengthening and microwave instability

Wake functions: general definition

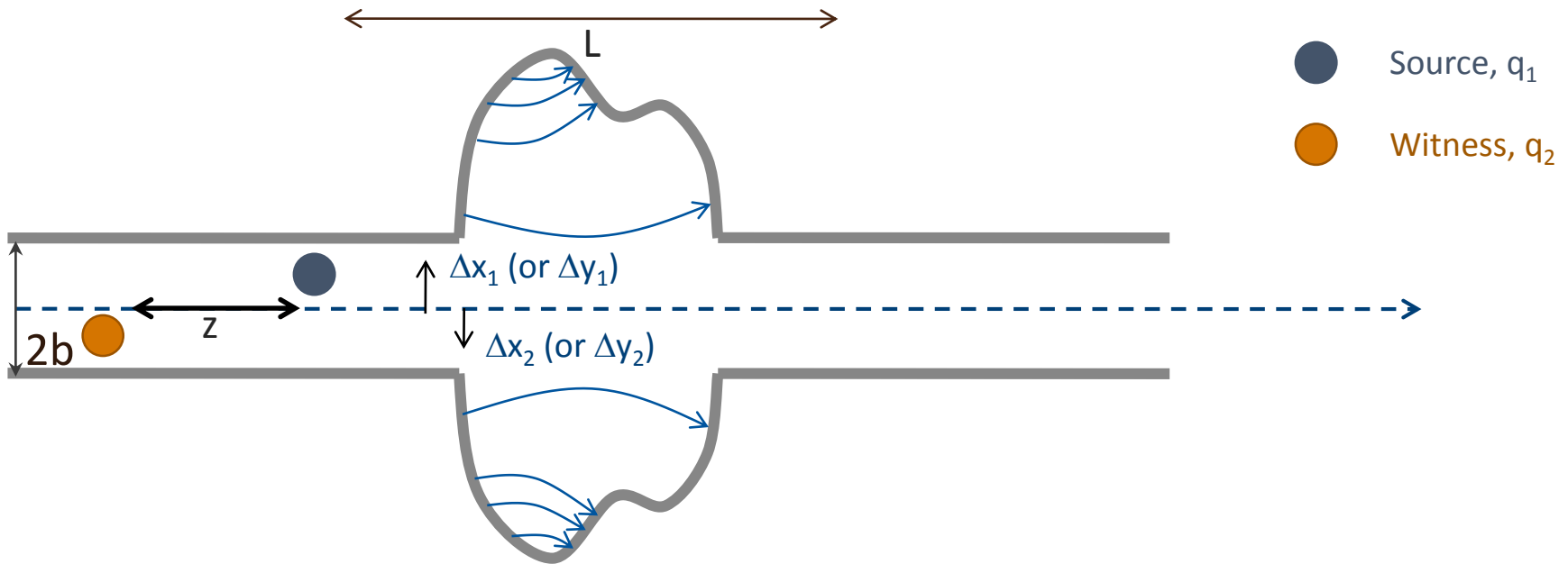

Wake function is the **integrated force** felt by a witness charge following a source charge, thus associated to an ‘energy kick’:

- In general, for two point-like particles, we have

$$\Delta E_2 = \int F(x_1, x_2, z, s) ds = -q_1 q_2 w(x_1, x_2, z)$$

w is typically expanded in the transverse offsets of source and witness particles. This yields the different types of wake fields (dipole, quadrupole, coupling wakes)

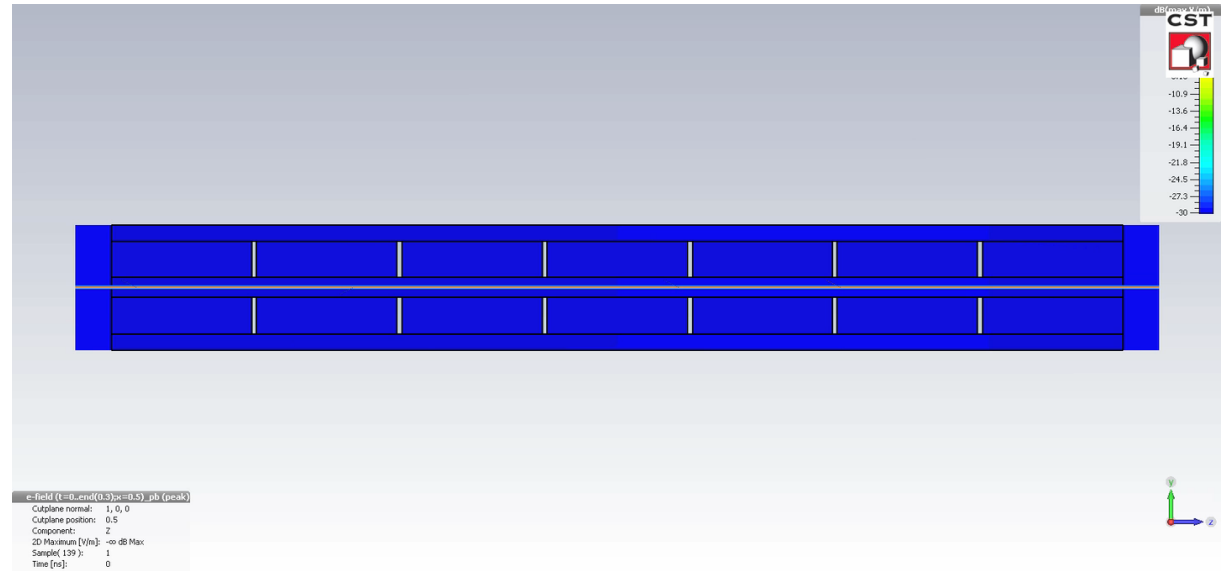
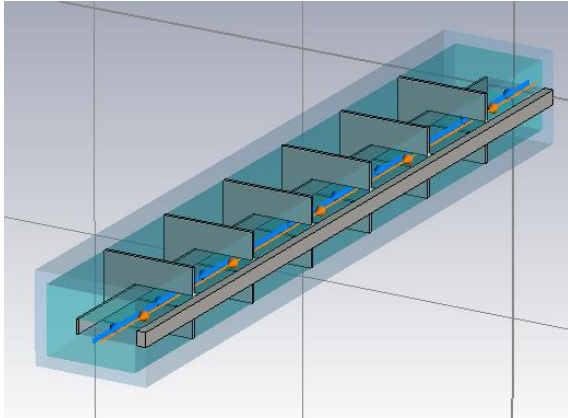

- The **wake function** is a type of **electromagnetic response** of a device to a charge pulse. It is an intrinsic property of this device and depends on
 - The device's **geometry** (transitions, cavities, etc.)
 - The **electromagnetic properties** of the materials exposed to the beam (e.g. PEC, finite conductivity, lossy materials, metamaterials, etc.)
- The wake function describes the **electromagnetic coupling between two point charges** as a function of the distance between them.

Longitudinal wake function

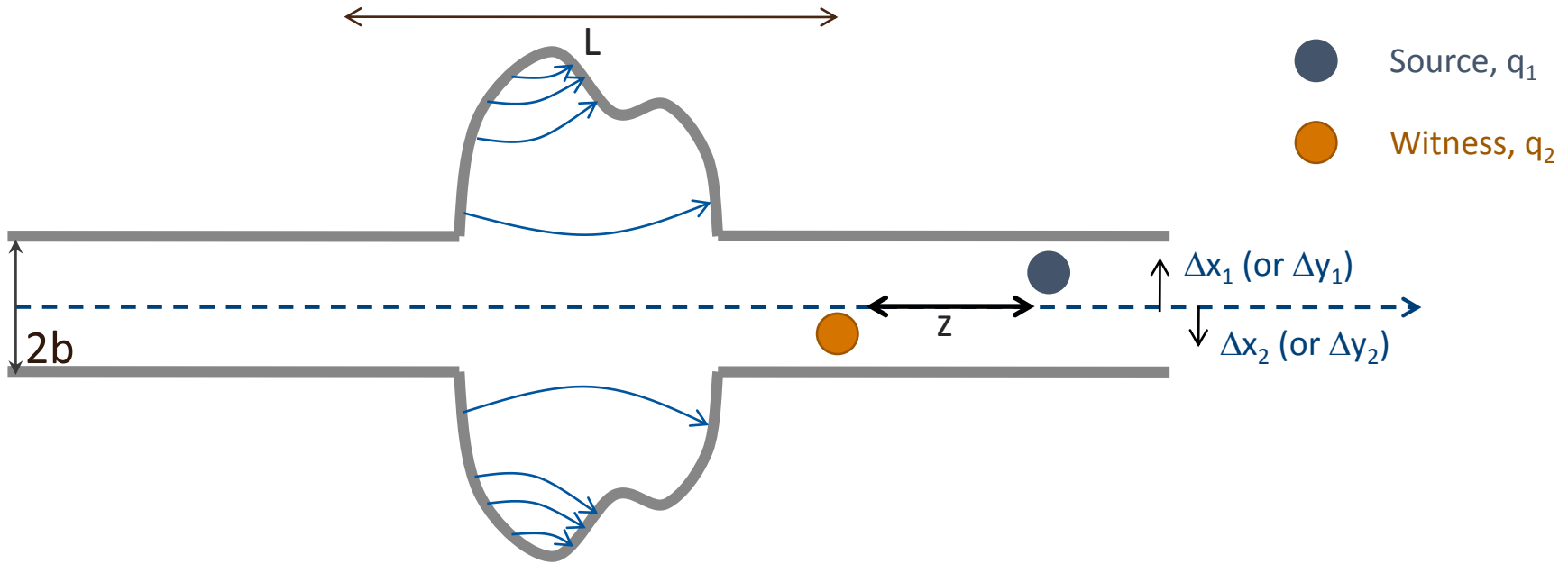

- Longitudinal wake fields

$$\int F_z(x_1, x_2, z, s) ds = -q_1 q_2 \left(\boxed{W_{\parallel}(z)} + \boxed{O(\Delta x_1) + O(\Delta x_2)} \right)$$

Zeroth order with source and test centred
usually dominant

Higher order terms
Usually negligible for small offsets

Longitudinal wake function

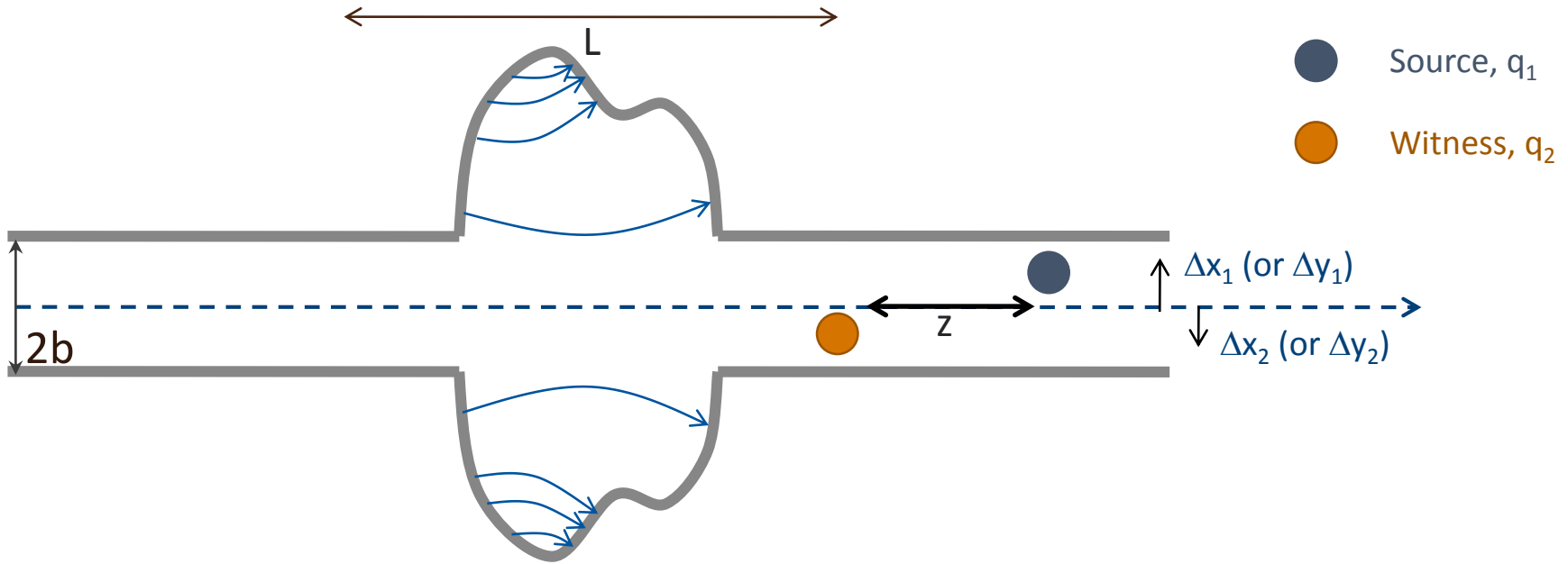

- Longitudinal wake fields

$$\Delta E_2 = \int F_z(z, s) ds = -q_1 q_2 W_{\parallel}(z)$$

$$\rightarrow \frac{\Delta E_2}{E_0} = \left(\frac{\gamma^2 - 1}{\gamma} \right) \frac{\Delta p_2}{p_0}$$

Energy kick of the witness particle from longitudinal wakes

Longitudinal wake function

$$W_{\parallel}(z) = -\frac{\Delta E_2}{q_1 q_2} \xrightarrow[q_2 \rightarrow q_1]{z \rightarrow 0} W_{\parallel}(0) = -\frac{\Delta E_1}{q_1^2}$$

- The value of the wake function in $z=0$ is related to the **energy lost by the source particle** in the creation of the wake
- $W_{\parallel}(0) > 0$ since $\Delta E_1 < 0$
- $W_{\parallel}(z)$ is discontinuous in $z=0$ and it vanishes for all $z > 0$ because of the ultra-relativistic approximation

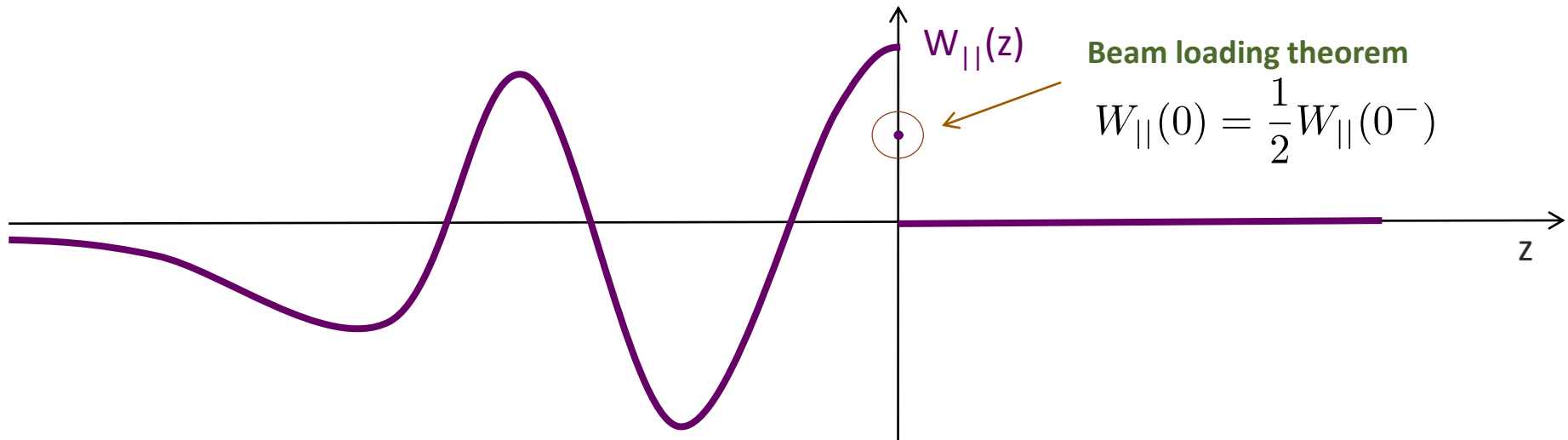

$$W_{\parallel}(z) = -\frac{\Delta E_2}{q_1 q_2} \xrightarrow[q_2 \rightarrow q_1]{z \rightarrow 0} W_{\parallel}(0) = -\frac{\Delta E_1}{q_1^2}$$

- The **wake function** of an accelerator component is basically its **Green function in time domain** (i.e., its response to a pulse excitation)
 - Very useful for macroparticle models and simulations, because it can be used to describe the driving terms in the single particle equations of motion!
- We can also describe it as a **transfer function in frequency domain**
 - This is the definition of **longitudinal beam coupling impedance** of the element under study

$$\boxed{Z_{\parallel}(\omega)} = \int_{-\infty}^{\infty} \boxed{W_{\parallel}(z)} \exp\left(-\frac{i\omega z}{c}\right) \frac{dz}{c}$$

\downarrow \downarrow

$[\Omega]$ $[\Omega/s]$

The energy balance

$$W_{\parallel}(0) = \frac{1}{\pi} \int_0^{\infty} \text{Re} (Z_{\parallel}(\omega)) d\omega = -\frac{\Delta E_1}{q_1^2}$$

What happens to the energy lost by the source?

- In the global energy balance, the energy lost by the source splits into:
 - Electromagnetic energy of the **modes that remain trapped** in the object
 - Partly dissipated on **lossy walls** or into purposely designed inserts or HOM absorbers
 - Partly transferred to **following particles** (or the same particle over successive turns), possibly feeding into an instability!
 - Electromagnetic energy of **modes that propagate** down the beam chamber (above cut-off), eventually lost on surrounding lossy materials

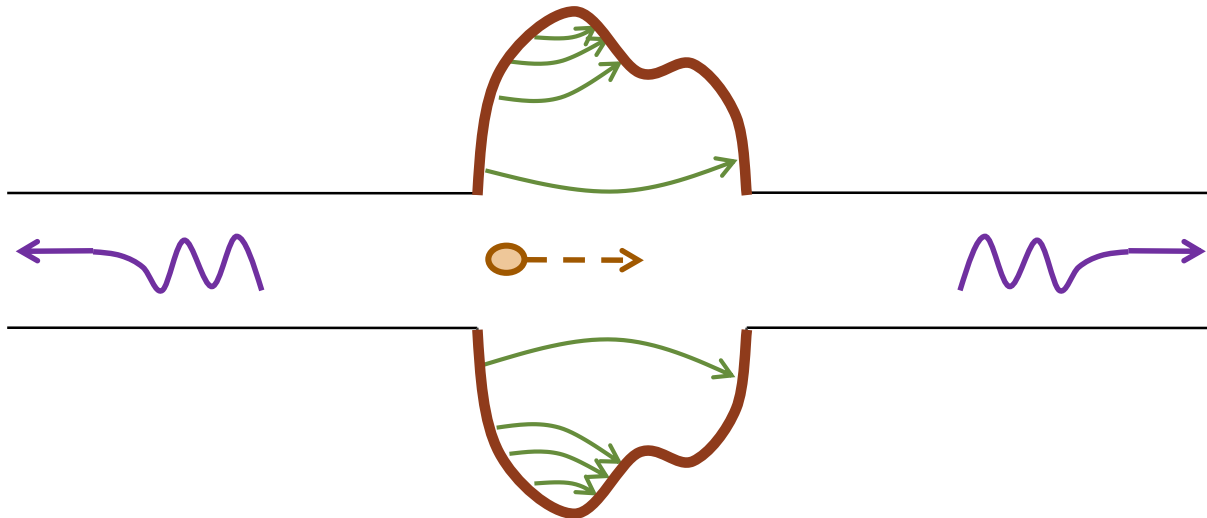

The energy balance

$$W_{\parallel}(0) = \frac{1}{\pi} \int_0^{\infty} \text{Re} (Z_{\parallel}(\omega)) d\omega = -\frac{\Delta E_1}{q_1^2}$$

What happens to the energy lost by the source?

- In the global energy balance, the energy lost by the source splits into

-

The energy loss of a particle bunch

-

- ⇒ causes **beam induced heating** of the machine elements (damage, outgassing) or **sparking** due to high field
- ⇒ feeds into both **longitudinal and transverse instabilities** through the associated EM fields
- ⇒ is compensated by the RF system determining a **stable phase shift**

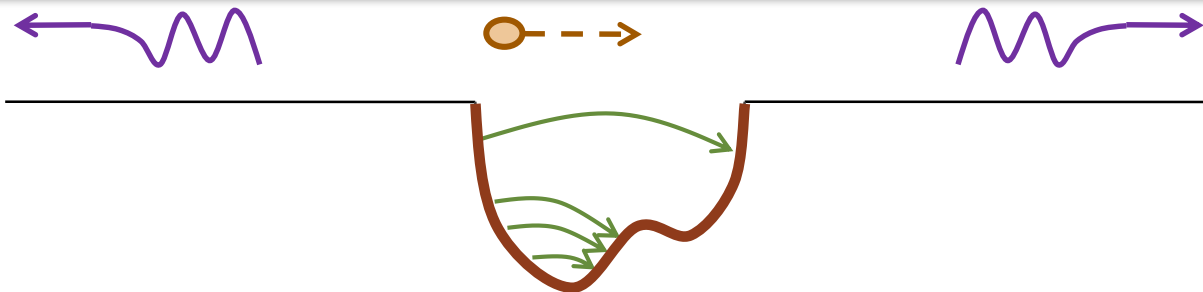

ct
absorbers
ve turns),
chamber

How are wakes and impedances computed?

- **Analytical or semi-analytical** approach, when geometry is simple (or simplified)
 - Solve Maxwell's equations with the correct source terms, geometries and boundary conditions up to an advanced stage
 - Find closed expressions or execute the last steps numerically to derive wakes and impedances

→ An example: **axisymmetric beam chamber** with several layers with different EM properties

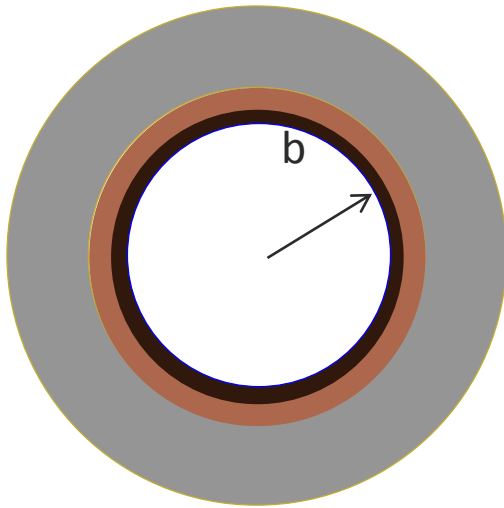

$$\nabla \times \vec{E} = -i\omega \vec{B}$$

$$\nabla \cdot \vec{E} = \frac{\tilde{\rho}}{\epsilon_0 \epsilon_1(\omega)}$$

$$\nabla \times \vec{B} = \mu_0 \mu_1(\omega) \vec{J} + i\omega \frac{\mu_1(\omega) \epsilon_1(\omega)}{c^2} \vec{E}$$

$$\nabla \cdot \vec{B} = 0$$

+ Boundary conditions

$$\tilde{\rho}(r, \theta, s, \omega) = \frac{q_1}{r_1 v} \delta(r - r_1) \delta_P(\theta) \exp\left(-\frac{i\omega s}{v}\right)$$

$$\vec{J}(r, \theta, s, \omega) = \tilde{\rho}(r, \theta, s, \omega) \vec{v}$$

How are wakes and impedances computed?

- **Analytical or semi-analytical** approach, when geometry is simple (or simplified)
 - Solve Maxwell's equations with the correct source terms, geometries and boundary conditions up to an advanced stage
 - Find closed expressions or execute the last steps numerically to derive wakes and impedances

→ We are interested in the longitudinal force on a test charge q_2 following the source q_1 at a distance z (wake per unit length of chamber)

$$F_s = q_2 E_s$$

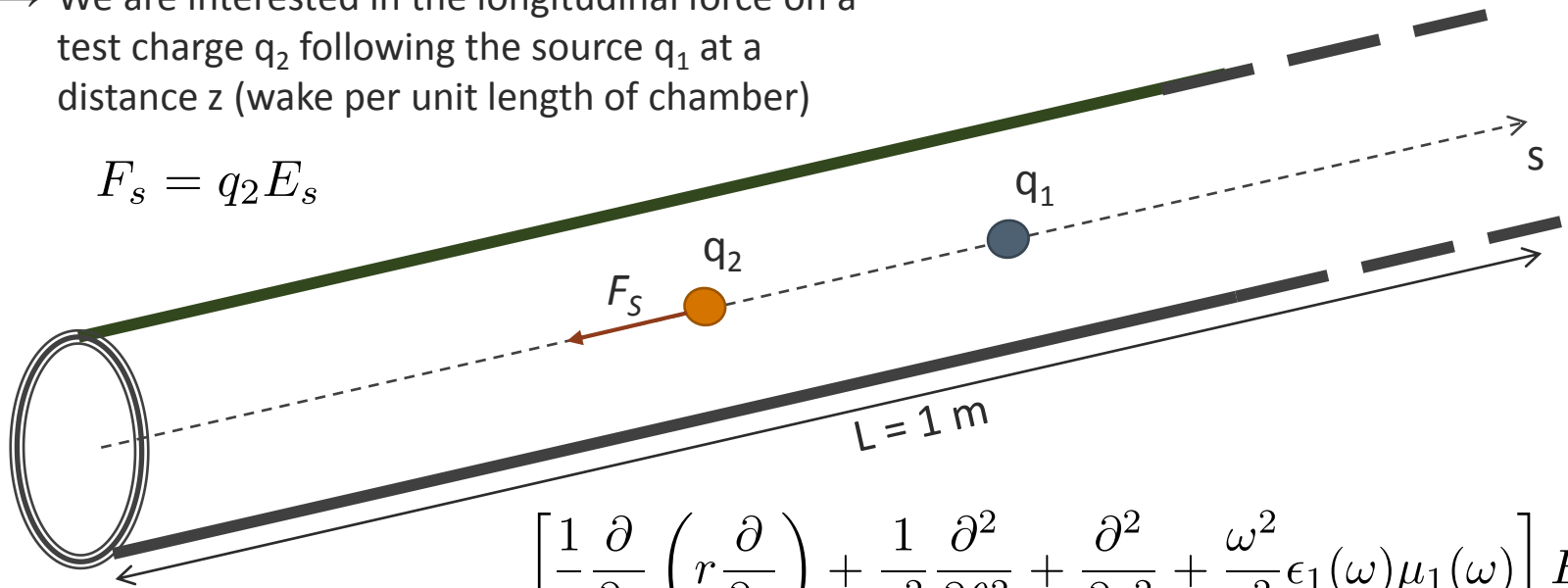

$$\left[\frac{1}{r} \frac{\partial}{\partial r} \left(r \frac{\partial}{\partial r} \right) + \frac{1}{r^2} \frac{\partial^2}{\partial \theta^2} + \frac{\partial^2}{\partial s^2} + \frac{\omega^2}{c^2} \epsilon_1(\omega) \mu_1(\omega) \right] E_s =$$

$$= \frac{1}{\epsilon_0 \epsilon_1(\omega)} \frac{\partial \tilde{\rho}}{\partial s} + i \omega \mu_0 \mu_1(\omega) \tilde{\rho} v$$

How are wakes and impedances computed?

- **Analytical or semi-analytical** approach, when geometry is simple (or simplified)
 - Solve Maxwell's equations with the correct source terms, geometries and boundary conditions up to an advanced stage
 - Find closed expressions or execute the last steps numerically to derive wakes and impedances

→ An example: a 1 m long Cu pipe with radius $b=2$ cm and thickness $t = 4$ mm in vacuum

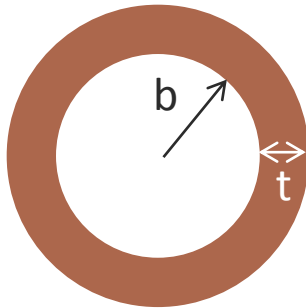

- Highlighted region shows the typical $\omega^{1/2}$ scaling
- Scaling is with respect to b :
 - Longitudinal impedance $\sim b^{-1}$

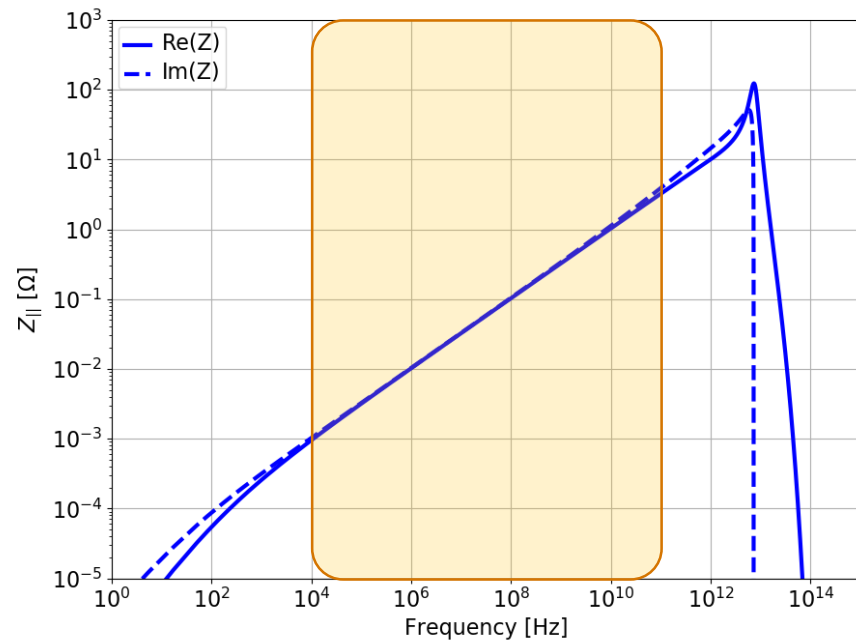

How are wakes and impedances computed?

- **Analytical or semi-analytical** approach, when geometry is simple (or simplified)
 - Solve Maxwell's equations with the correct source terms, geometries and boundary conditions up to an advanced stage
 - Find closed expressions or execute the last steps numerically to derive wakes and impedances

→ An example: a 1 m long Cu pipe with radius $b=2$ cm and thickness $t = 4$ mm in vacuum

\mathcal{F}^{-1}

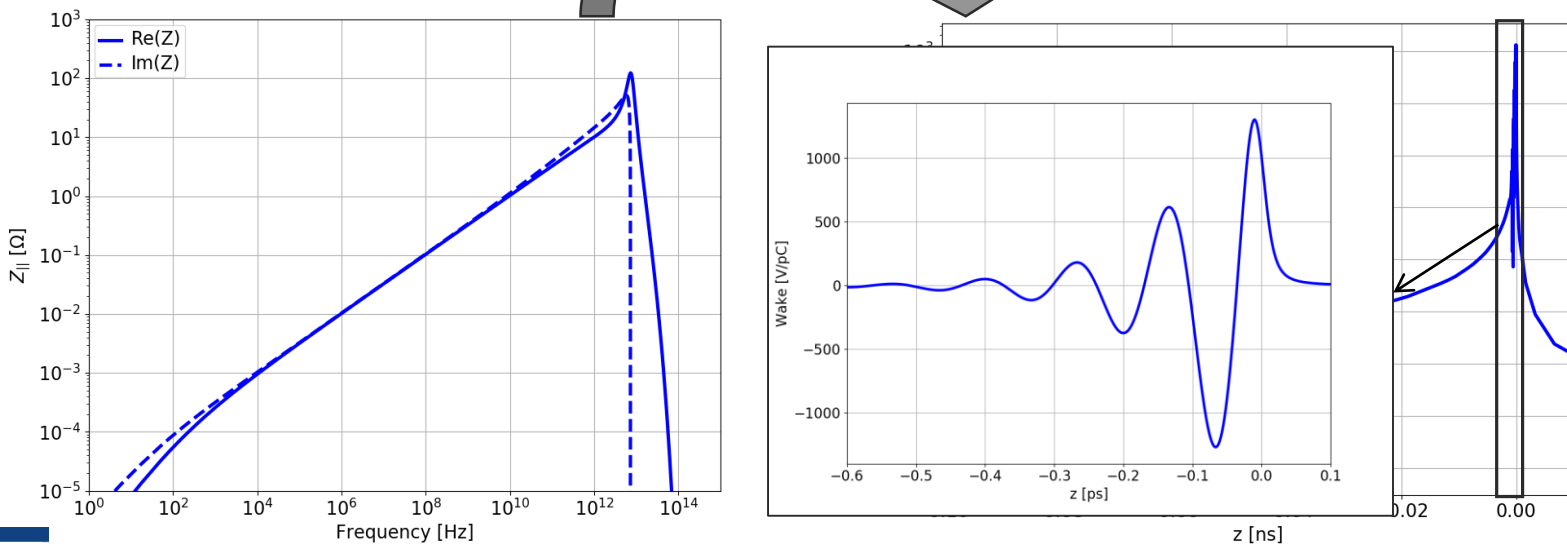

How are wakes and impedances computed?

• Numerical approach

- Different codes have been developed over the years to solve numerically Maxwell's equations in arbitrarily complicated structures
- Examples are CST Studio Suite (Particle Studio, Microwave Studio), ABCI, GdFidL, HFSS, ECHO2(3)D. Exhaustive list can be found from the program of the [ICFA mini-Workshop on "Electromagnetic wake fields and impedances in particle accelerators"](#), Erice, Sicily, 23-28 April, 2014
- Computations can become very **challenging** if high frequency resolution (long wake) or knowledge of impedance spectrum at high frequency (short excitation) are required, especially for large/complicated geometries

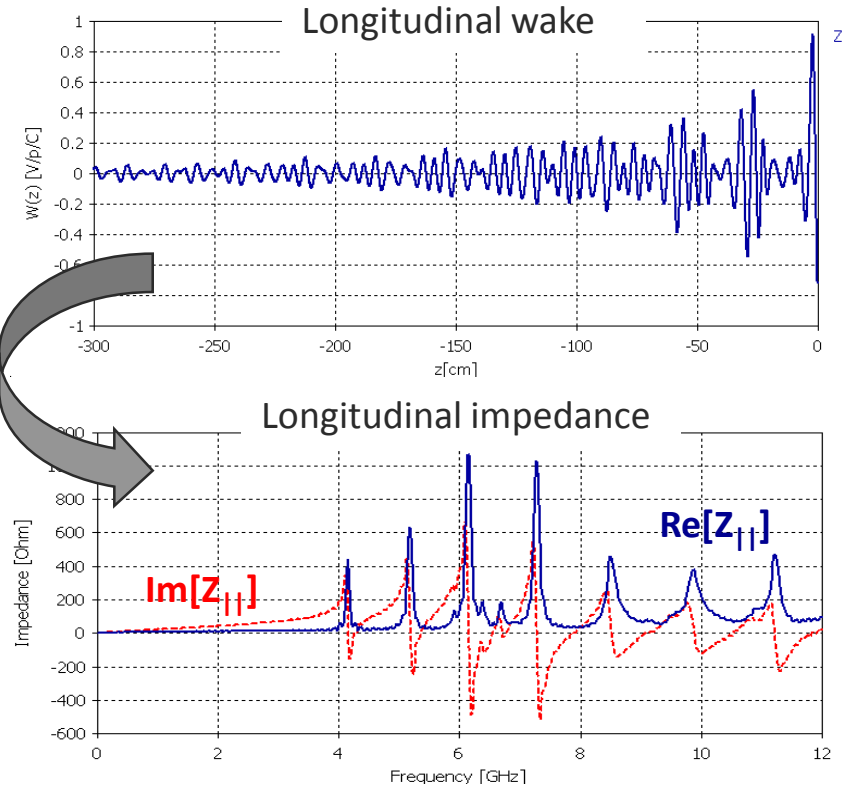
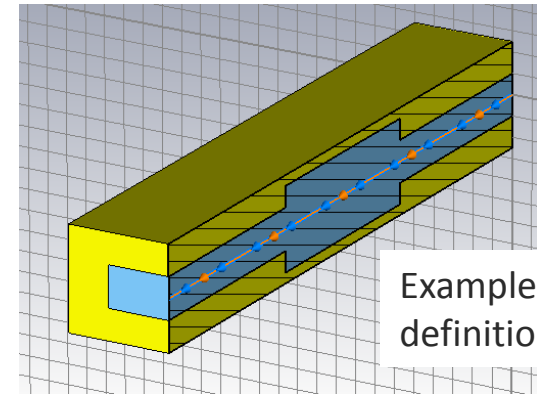

How are wakes and impedances computed?

Numerical approach

- To limit numerical noise, in cases with many resonances, the resonances are first characterized through their frequencies (ω_{r_i}), shunt impedances (R_{s_i}) and quality factors (Q_i)

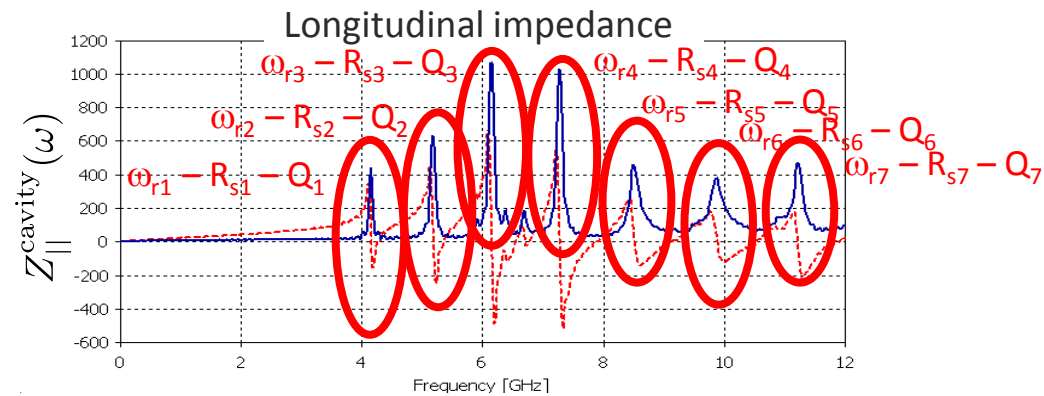

- Then analytical formulae for resonators are used in computations

$$Z_{||}^{\text{Res}}(\omega) = \frac{R_{s||}}{1 + iQ \left(\frac{\omega}{\omega_r} - \frac{\omega_r}{\omega} \right)}$$

$$W_{||}^{\text{Res}}(z) = \begin{cases} 2\alpha_z R_{s||} \exp\left(\frac{\alpha_z z}{c}\right) \left[\cos\left(\frac{\bar{\omega} z}{c}\right) + \frac{\alpha_z}{\bar{\omega}} \sin\left(\frac{\bar{\omega} z}{c}\right) \right] & \text{if } z < 0 \\ \alpha_z R_{s||} & \text{if } z = 0 \\ 0 & \text{if } z > 0 \end{cases}$$

$$\alpha_z = \frac{\omega_r}{2Q} \quad \bar{\omega} = \sqrt{\omega_r^2 - \alpha_z^2}$$

$$Z_{||}^{\text{cavity}}(\omega) = \sum Z_{||i}^{\text{Res}}(\omega)$$

How are wakes and impedances computed?

- **Bench measurements** based on transmission/reflection measurements with stretched wires
 - Seldom used independently to assess impedances due to the perturbation introduced by the measurement set up (flanging, presence of wire)
 - Usefulness mainly lies in that they can be used for validating 3D EM models for simulations

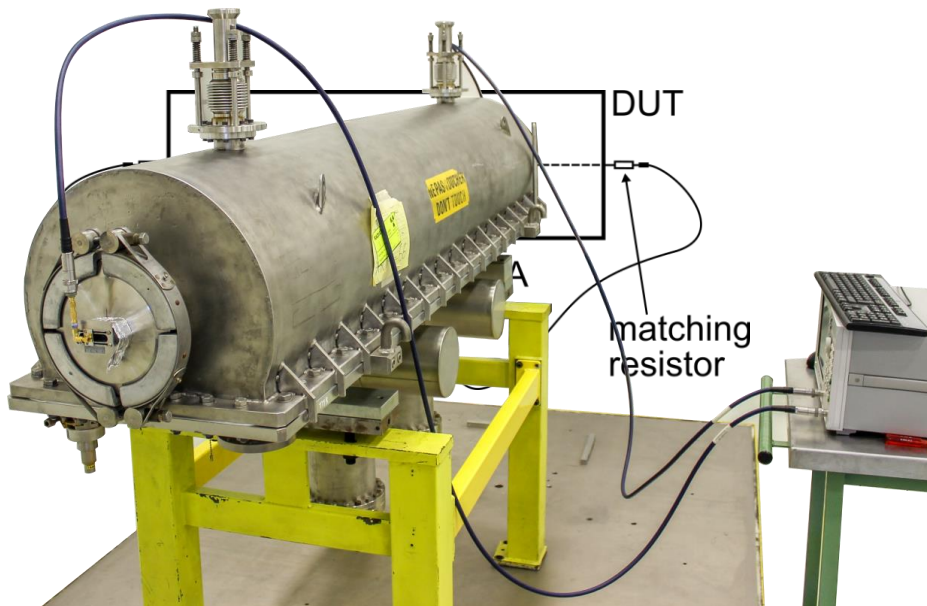

- A **wire** is stretched in the middle of the device to simulate the beam
- **Reflection and transmission coefficients** are measured via a VNA
- The impedance can be calculated by plugging the measured scattering parameters into the **LOG formula**

$$Z_{||} = 2Z_L \ln(S_{21})$$

- We have learnt what is a wake function and how it is defined in the **longitudinal plane**. We have introduced the **longitudinal impedance**
- We have seen how longitudinal wake functions are related to the **energy loss** of the source particles.
- We have discussed the **energy balance** which contains all the **fundamental underlying mechanisms** for collective effects related to wake fields and impedances.
- We have shown how wake functions and impedances **can be computed**

Part 2: Multiparticle dynamics with wake fields – impact on machine elements and longitudinal beam dynamics

- General introduction to wake fields
- Longitudinal wake function and impedance
- Energy loss – beam induced heating and stable phase shift
- Potential well distortion, bunch lengthening and microwave instability

Bunch energy loss per turn

- Single traversal of a bunch through an impedance source
 - We assume a single bunch of particles that goes only once through a known (characterized) wake/impedance source, representing both
 - Single passage (e.g. in a line)
 - Energy loss per turn if the bunch passes every turn but the wake fully decays between subsequent turns
 - Our goal is to calculate how much energy the bunch loses in this passage due to the electromagnetic interaction

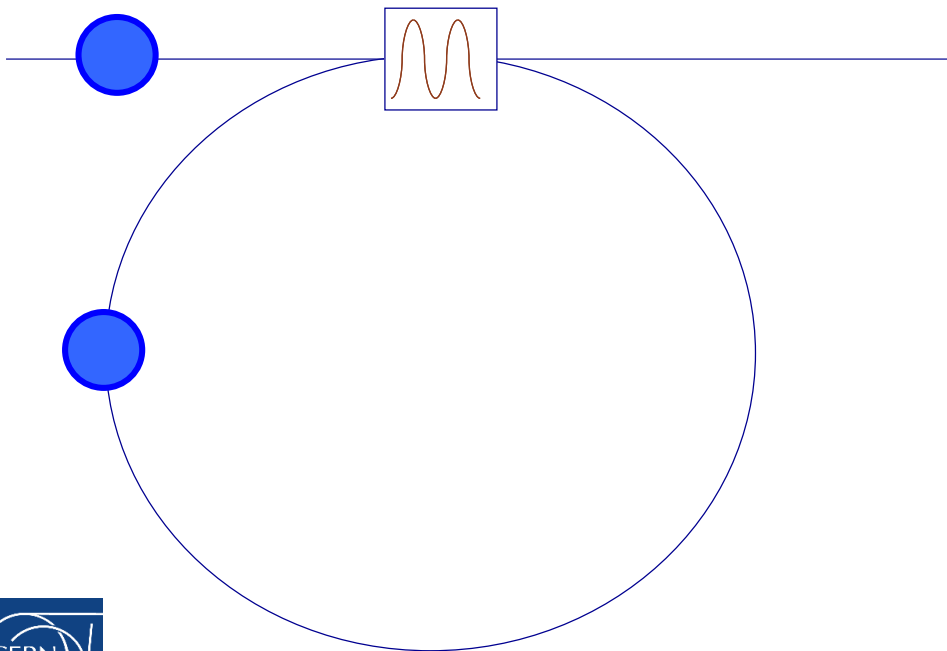

Bunch energy loss per turn

- Single traversal of a bunch through an impedance source

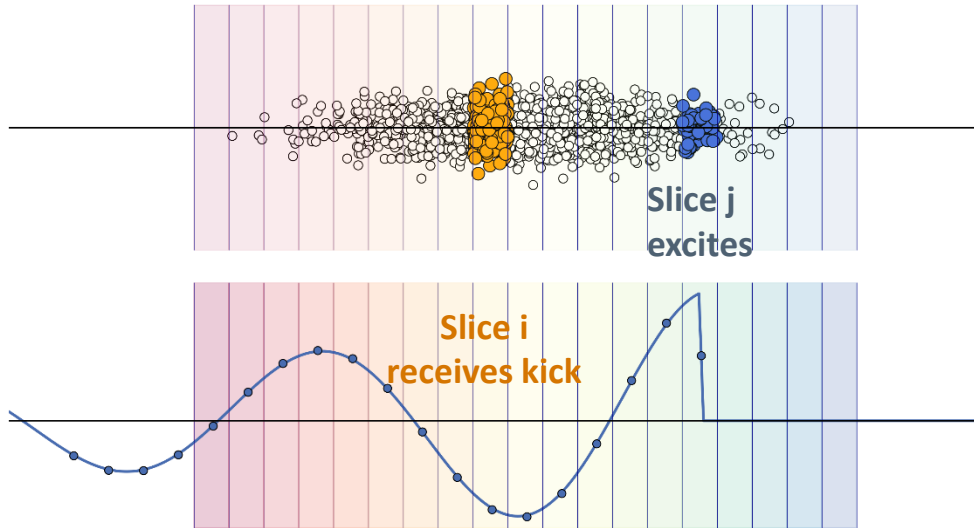

$$\Delta E_{ij} = -e^2 W_{||}(z_{ij})$$

$$\Delta E_{bunch} = -e^2 \sum_{j=1}^{N_b} \sum_{i=1}^{N_b} W_{||}(z_{ij})$$

$$\Delta E_{ij} = -e^2 N[j]N[i]W_{||}[(i-j)\Delta z]$$

$$\Delta E_i = -e^2 N[i] \sum_{j=0}^i N[j]W_{||}[(i-j)\Delta z]$$

Bunch energy loss per turn

- Single traversal of a bunch through an impedance source

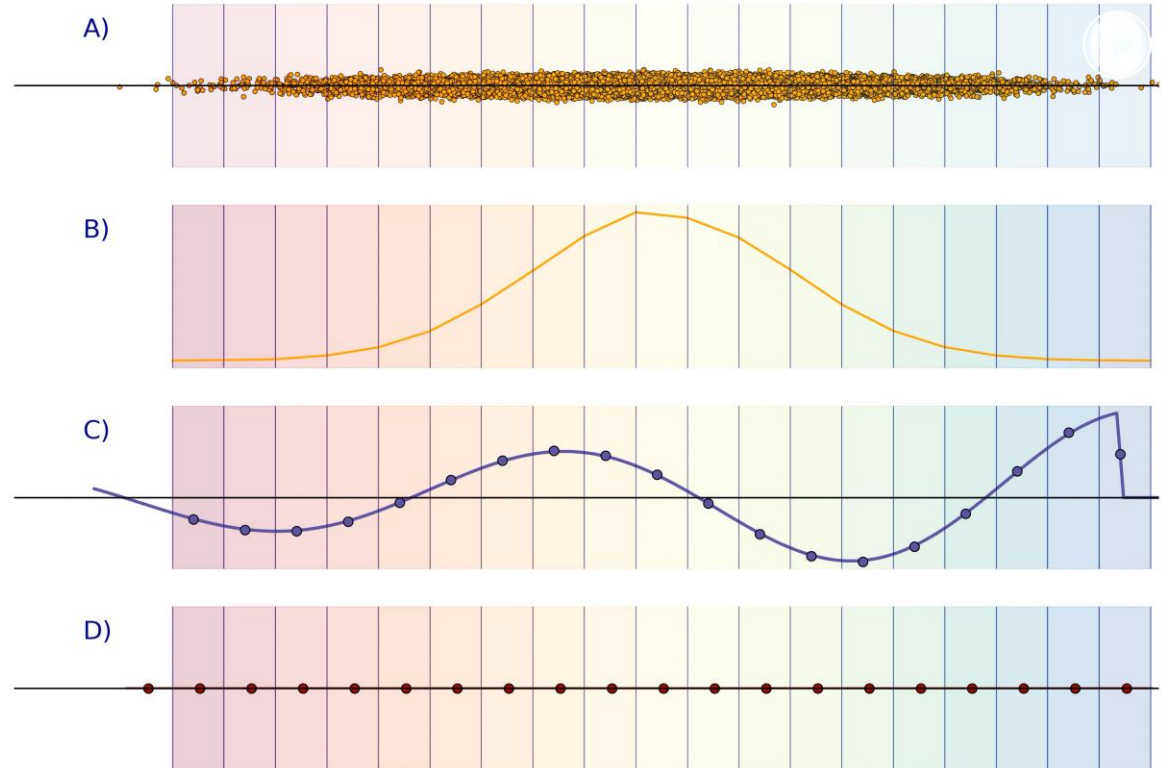

$$\Delta E_i = -e^2 N[i] \sum_{j=0}^i N[j] W_{||}[(i-j)\Delta z]$$

Bunch energy loss per turn

- Single traversal of a bunch through an impedance source

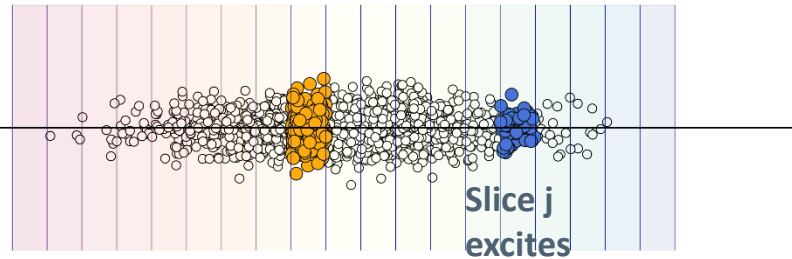

$$\Delta E_{ij} = -e^2 W_{||}(z_{ij})$$

$$\Delta E_{bunch} = -e^2 \sum_{j=1}^{N_b} \sum_{i=1}^{N_b} W_{||}(z_{ij})$$

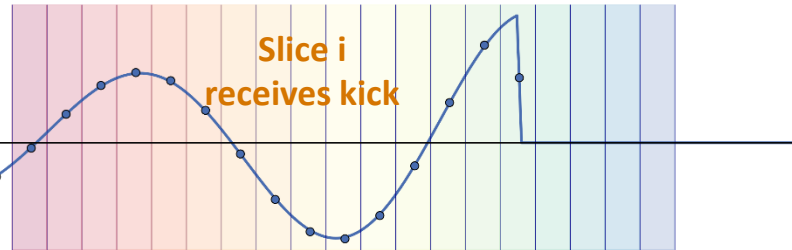

$$\Delta E_{ij} = -e^2 N[j] N[i] W_{||}[(i - j) \Delta z]$$

$$\Delta E_i = -e^2 N[i] \sum_{j=0}^i N[j] W_{||}[(i - j) \Delta z]$$

$$\Delta E_{bunch} = -e^2 \sum_{i=0}^{N_{slices}} N[i] \sum_{j=0}^i N[j] W_{||}[(i - j) \Delta z]$$

Bunch energy loss per turn

- Single traversal of a bunch through an impedance source

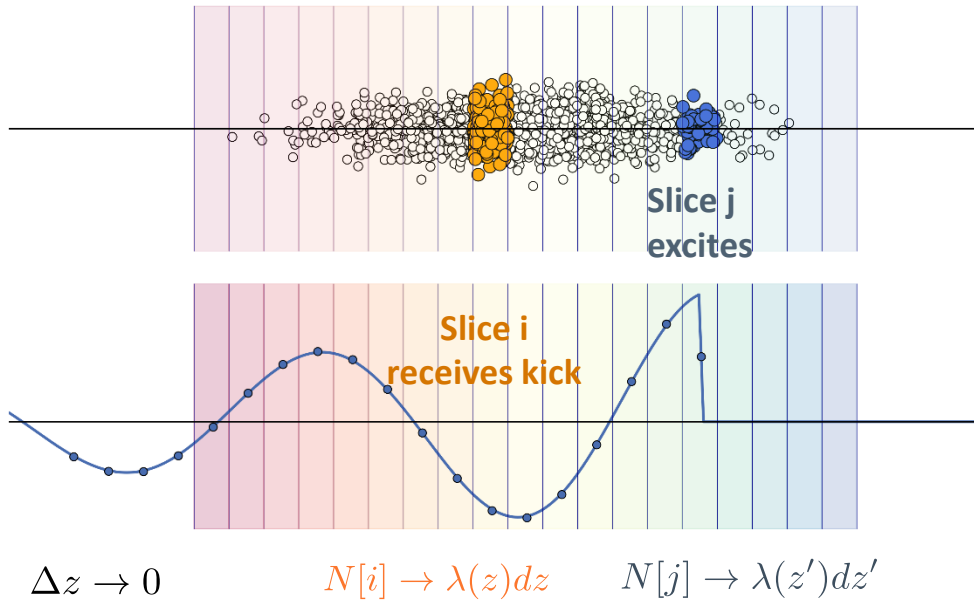

$$\Delta E_{ij} = -e^2 W_{||}(z_{ij})$$

$$\Delta E_{bunch} = -e^2 \sum_{j=1}^{N_b} \sum_{i=1}^{N_b} W_{||}(z_{ij})$$

$$\Delta E_{ij} = -e^2 N[j] N[i] W_{||}[(i - j)\Delta z]$$

$$\Delta E_i = -e^2 N[i] \sum_{j=0}^i N[j] W_{||}[(i - j)\Delta z]$$

$$\Delta E_{bunch} = -e^2 \int \lambda(z) dz \int \lambda(z') W_{||}(z - z') dz'$$

$$\Delta E_{bunch} = -\frac{e^2}{2\pi} \int \left| \hat{\lambda}(\omega) \right|^2 \text{Re} [Z_{||}(\omega)]$$

Bunch energy loss per turn

- Multiple traversal of a bunch through an impedance source
 - We assume a single bunch of particles that goes multiple times through a known (characterized) wake/impedance source, representing
 - Energy loss per turn if the bunch passes every turn and the wake fully keeps ringing between subsequent turns
 - Our goal is to calculate how much energy the bunch loses at each passage due to the electromagnetic interaction over several turns

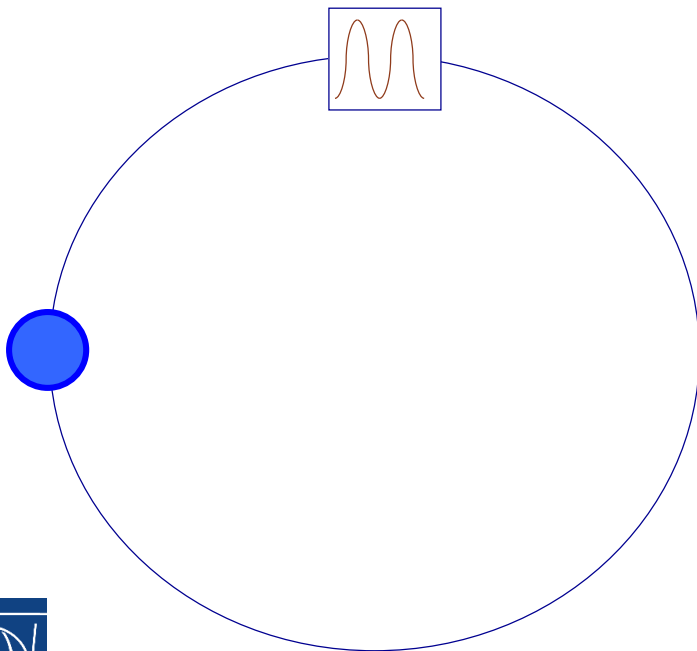

Bunch energy loss per turn

$$\Delta E = -\frac{e^2}{2\pi} \int_{-\infty}^{\infty} \lambda(z) dz \int_{-\infty}^{\infty} dz' \lambda(z') \underbrace{\sum_{k=-\infty}^{\infty} W_{\parallel}(kC + z - z')}_{k=-\infty} dz'$$

$\lambda(z' + kC) = \lambda(z')$, i.e. assuming that the distribution doesn't change from turn to turn

$$\sum_{k=-\infty}^{\infty} W_{\parallel}(kC + z - z') = \frac{c}{C} \sum_{p=-\infty}^{\infty} Z_{\parallel}(p\omega_0) \exp\left[-\frac{ip\omega_0(z - z')}{c}\right]$$

$$\Delta E = -\frac{e^2\omega_0}{2\pi} \sum_{p=-\infty}^{\infty} Z_{\parallel}(p\omega_0) \underbrace{\int_{-\infty}^{\infty} \lambda(z) \exp\left(\frac{-ip\omega_0 z}{c}\right) dz}_{\hat{\lambda}(p\omega_0)} \underbrace{\int_{-\infty}^{\infty} \lambda(z') \exp\left(\frac{ip\omega_0 z'}{c}\right) dz'}_{\hat{\lambda}^*(p\omega_0)}$$

$$\Delta E = -\frac{e^2\omega_0}{2\pi} \sum_{p=-\infty}^{\infty} \left| \hat{\lambda}(p\omega_0) \right|^2 \operatorname{Re} [Z_{\parallel}(p\omega_0)]$$

Beam energy loss per turn

Replacing the **bunch spectrum with the beam spectrum**, we can calculate the energy loss from a beam

Bunch profile and spectrum

$$\lambda(z)$$

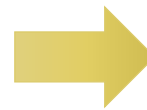
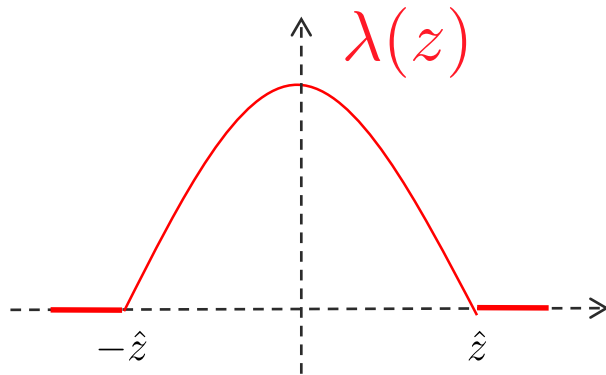

Beam profile and spectrum

$$\Lambda_{\text{beam}}(z)$$

$$\Lambda_{\text{beam}}(z)$$

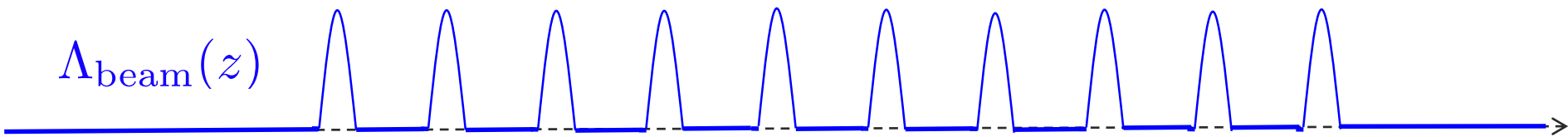

Beam energy loss per turn

Replacing the **bunch spectrum with the beam spectrum**, we can calculate the energy loss from a beam

Bunch profile and spectrum

$$\lambda(z) \leftrightarrow \hat{\lambda}(\omega)$$

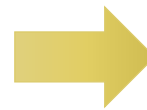

Beam profile and spectrum

$$\Lambda_{\text{beam}}(z)$$

Ex. parabolic, as shown in the previous slide

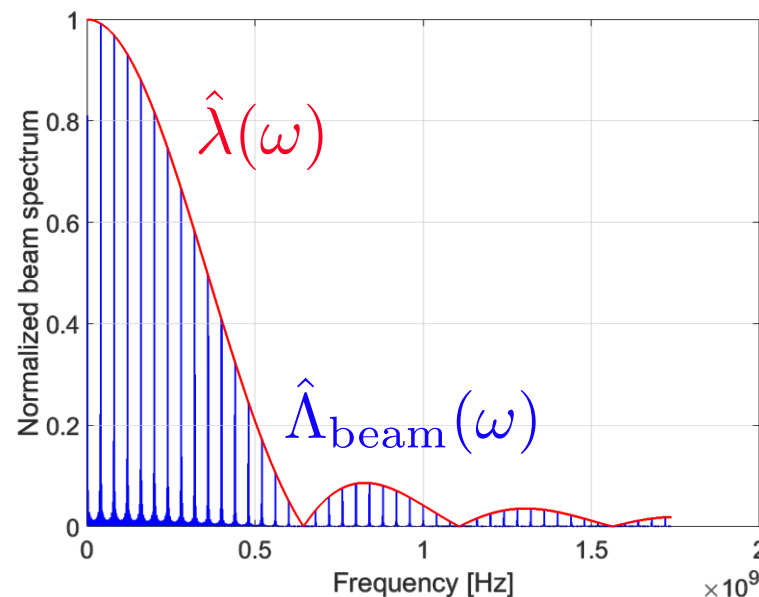

$$\Delta E_{\text{beam}} = -\frac{e^2 \omega_0}{2\pi} \sum_{p=-\infty}^{+\infty} |\Lambda_{\text{beam}}(p\omega_0)|^2 \text{Re} [Z_{||}(p\omega_0)]$$

Beam energy loss per turn

Replacing the **bunch spectrum with the beam spectrum**, we can calculate the energy loss from a beam

Bunch profile and spectrum

$$\lambda(z) \leftrightarrow \hat{\lambda}(\omega)$$

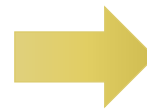

Beam profile and spectrum

$$\Lambda_{\text{beam}}(z) \leftrightarrow \hat{\Lambda}_{\text{beam}}(\omega)$$

Or for a train of
Gaussian bunches

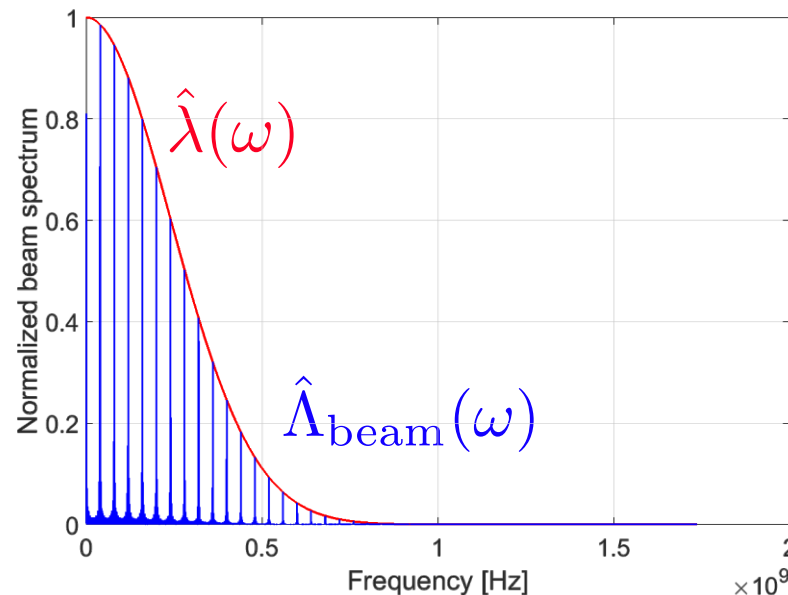

$$\Delta E_{\text{beam}} = -\frac{e^2 \omega_0}{2\pi} \sum_{p=-\infty}^{+\infty} |\Lambda_{\text{beam}}(p\omega_0)|^2 \text{Re} [Z_{||}(p\omega_0)]$$

Energy loss of a train of M identical bunches

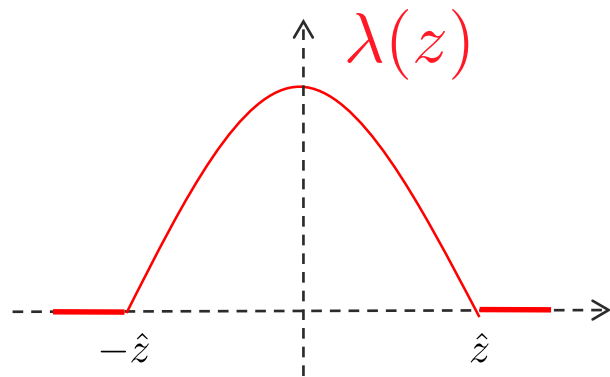

A train of M identical equally spaced bunches circulating in a ring

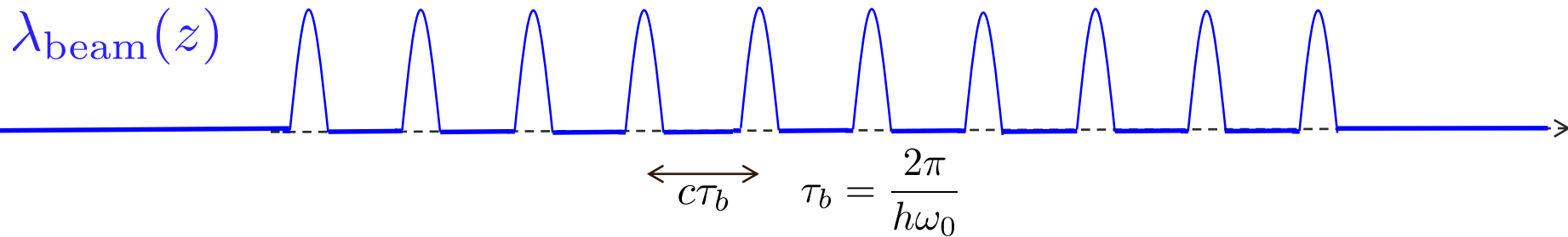

$$\lambda_{\text{beam}}(z) = \sum_{n=0}^{M-1} \lambda(z - n c \tau_b) \quad \stackrel{\mathcal{F}}{\iff} \quad \Lambda_{\text{beam}}(\omega) = \hat{\lambda}(\omega) \sum_{n=0}^{M-1} \exp(-i n \omega \tau_b)$$

Energy loss of a train of M identical bunches

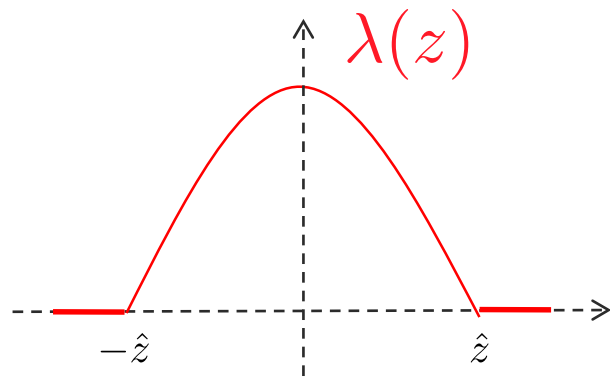

A train of M identical equally spaced bunches circulating in a ring

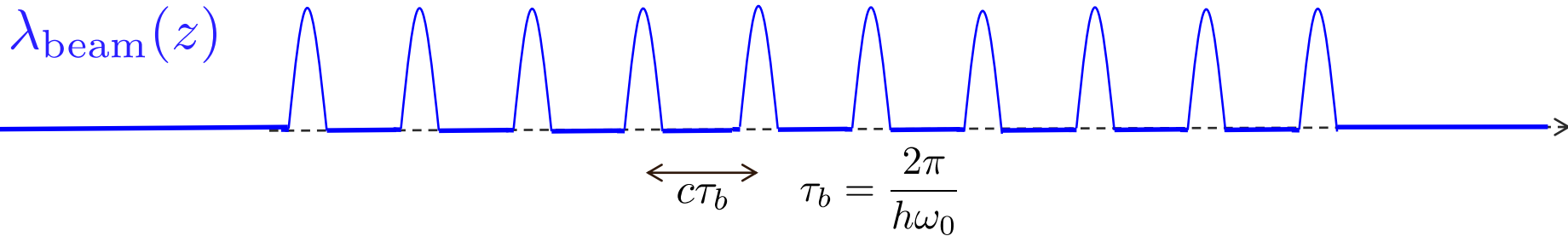

$$\Delta E_{\text{beam}} = \frac{e^2 \omega_0}{2\pi} \sum_{p=-\infty}^{+\infty} \left| \hat{\lambda}(p\omega_0) \right|^2 \text{Re} [Z_{\parallel}(p\omega_0)] \cdot \left[\frac{1 - \cos\left(\frac{2\pi M p}{h}\right)}{1 - \cos\left(\frac{2\pi p}{h}\right)} \right]$$

Energy loss of a train of M identical bunches

$$\Delta E_{\text{beam}} = \frac{e^2 \omega_0}{2\pi} \sum_{p=-\infty}^{+\infty} \left| \hat{\lambda}(p\omega_0) \right|^2 \text{Re} [Z_{||}(p\omega_0)] \cdot \left[\frac{1 - \cos \left(\frac{2\pi M p}{h} \right)}{1 - \cos \left(\frac{2\pi p}{h} \right)} \right]$$

- The potential leading terms in the summation are those with $p = k \cdot h$, as the ratio in brackets tends to M^2 .
- Narrow-band impedances peaked around multiples of the harmonic number of the accelerator are **the most efficient to drain energy** from the beam → beam induced heating, instabilities.
- This type of impedances, usually **associated to the RF systems** and their higher order modes (HOMs), **need mitigation** in the accelerator design (e.g. detuners, HOM absorbers).

Application to the SPS extraction kickers

- Problem with SPS extraction kickers (MKE)
 - Extraction elements through which the beam passes every turn
 - Based on a fast pulsed magnet capable of deflecting the whole beam over one turn
 - Active only on turn in which beam has to be extracted, otherwise passive but with all its elements (ferrite, conductors) exposed to the beam

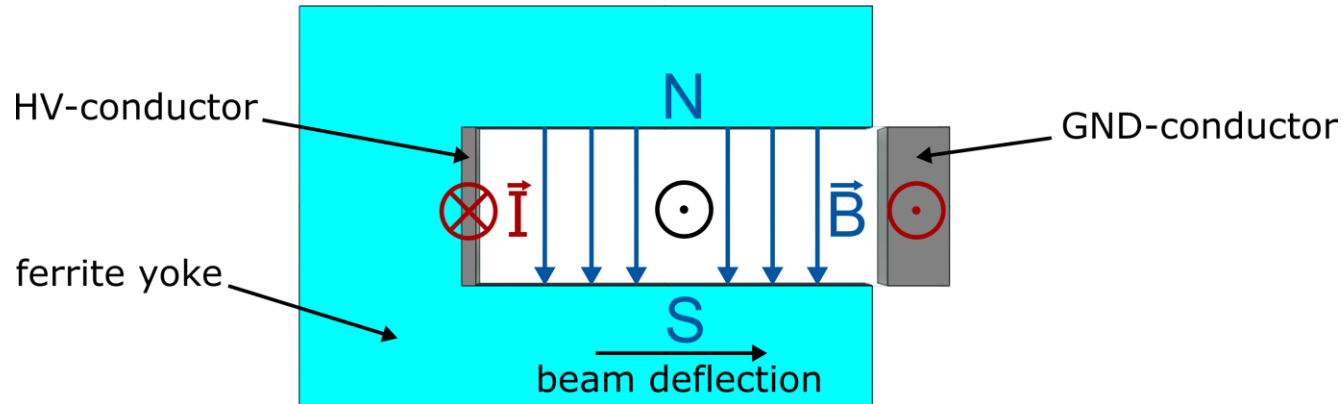

Application to the SPS extraction kickers

- Problem with SPS extraction kickers (MKE)
 - Extraction elements through which the beam passes every turn
 - Based on a fast pulsed magnet capable of deflecting the whole beam over one turn
 - Active only on turn in which beam has to be extracted, otherwise passive but with all its elements (ferrite, conductors) exposed to the beam
 - Use of beam for LHC filling (4x 200-ns spaced trains of 72x 25-ns spaced bunches) led to unacceptable heating of these elements
 - Heating above Curie temperature leads to ferrite degradation → Beam cannot be extracted anymore from the SPS
 - Heating causes outgassing and strong pressure rise in the kicker sector, with consequent beam interlocking due to poor vacuum

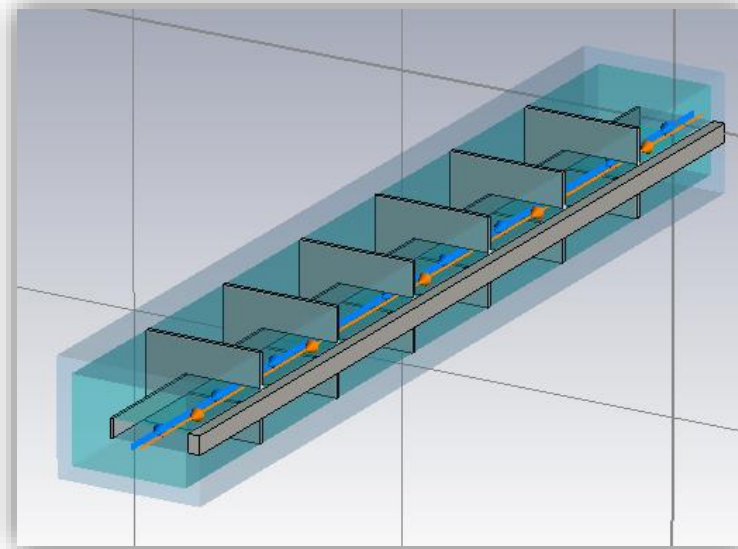

Application to the SPS extraction kickers

- We need to calculate the power loss in the kicker
 - Kicker impedance can be evaluated semi-analytically or via simulations
 - Then we apply the energy loss formula

$$\Delta E_{\text{beam}} = -\frac{e^2 \omega_0}{2\pi} \sum_{p=-\infty}^{+\infty} |\Lambda_{\text{beam}}(p\omega_0)|^2 \text{Re} [Z_{||}(p\omega_0)]$$

$$\Delta W = \frac{\Delta E_{\text{beam}}}{T_0}$$

Application to the SPS extraction kickers

- We need to calculate the power loss in the kicker
 - Kicker impedance can be evaluated semi-analytically or via simulations
 - Then we apply the energy loss formula
- Kicker impedance already becomes significant at frequencies for which the beam spectrum has not fully decayed, causing the undesired heating
- We need to lower the kicker impedance → Impedance dominated by losses in ferrite → Ferrite shielding

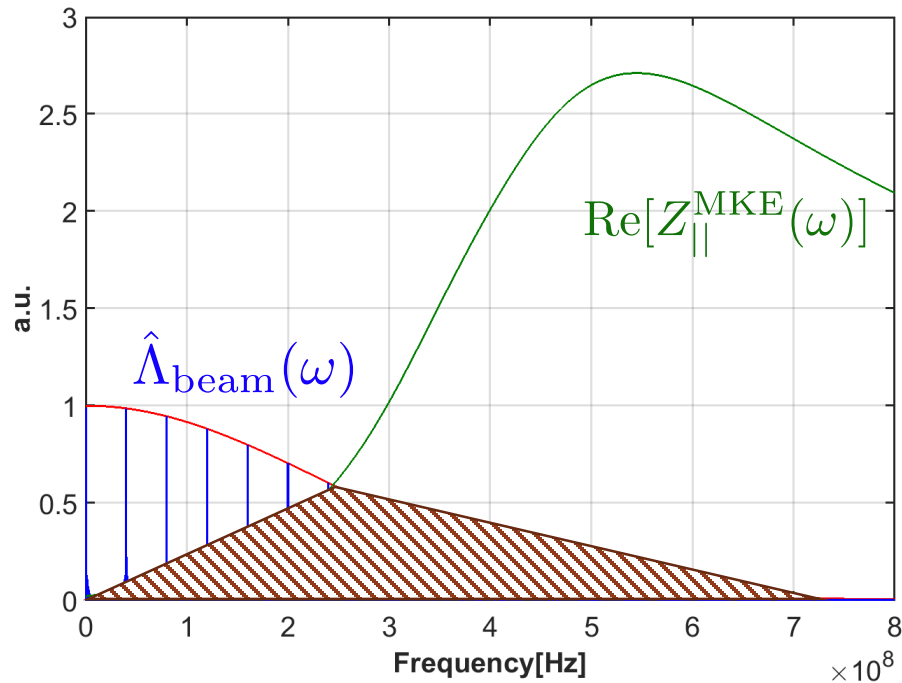

Application to the SPS extraction kickers

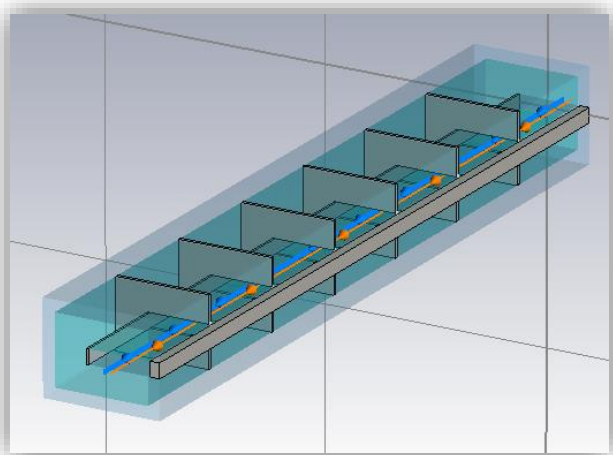

Print striped pattern of good conductor on ferrite (serigraphy)

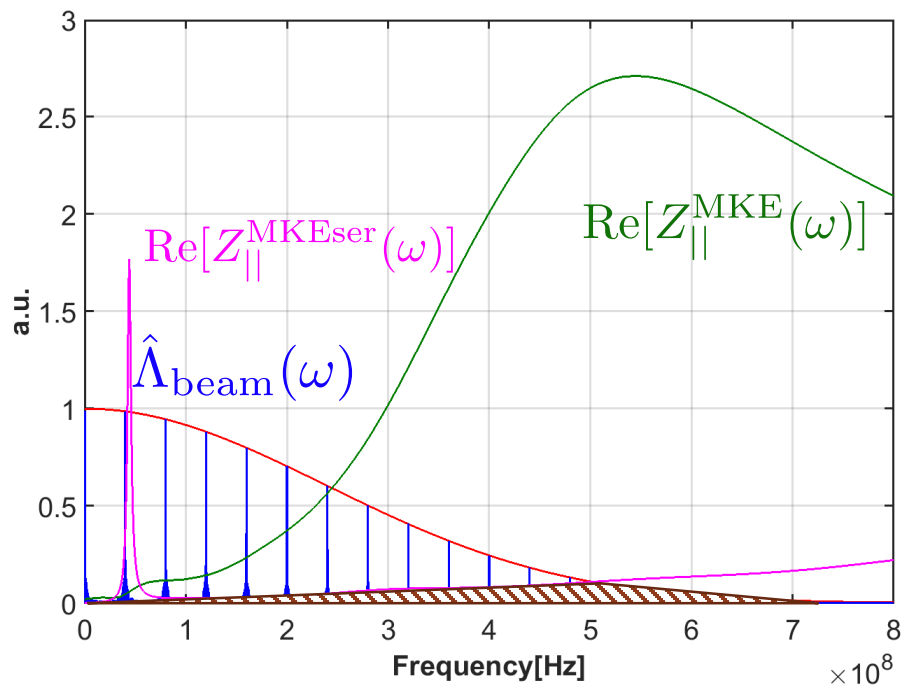
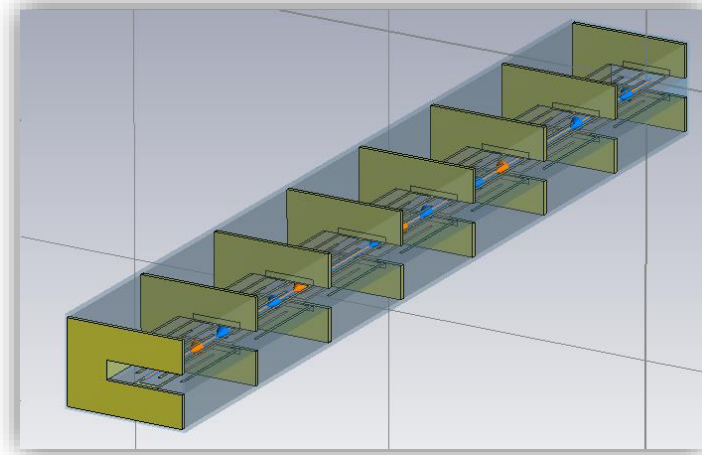

Application to the SPS extraction kickers

- This almost suppresses the impedance over the bunch spectrum
- It however introduces a low frequency peak, which needs to be kept far from beam spectral lines
 - Pay attention to do that for all needed bunch spacings

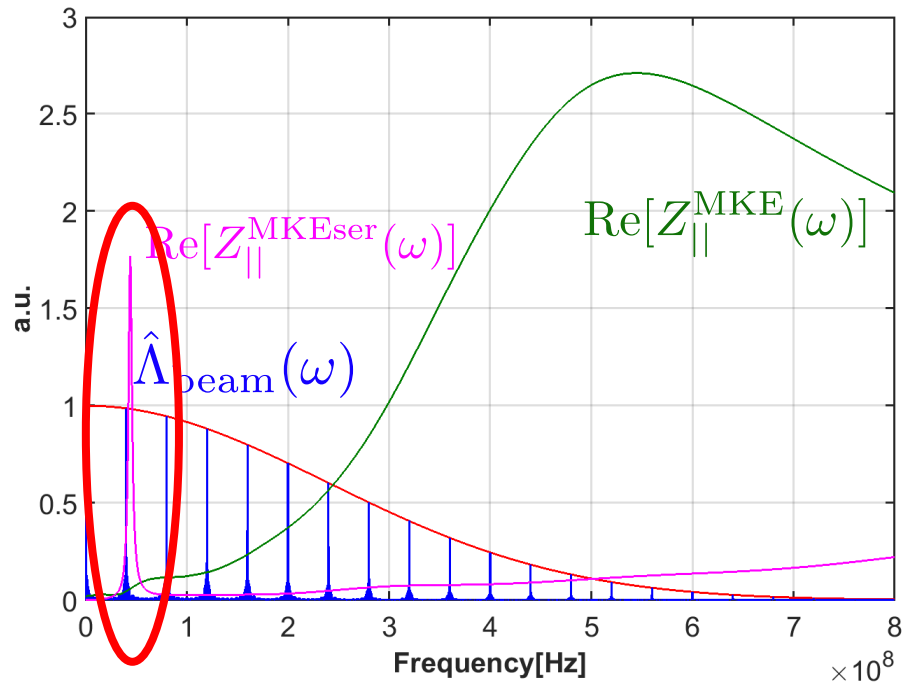

Application to the SPS extraction kickers

- This almost suppresses the impedance over the bunch spectrum
- It however introduces a low frequency peak, which needs to be kept far from beam spectral lines
- Expected up to 12-fold reduction of heat load, depending on bunch length and bunch spacing
 - Factor 4 for 25-ns LHC-type beam at 26 GeV

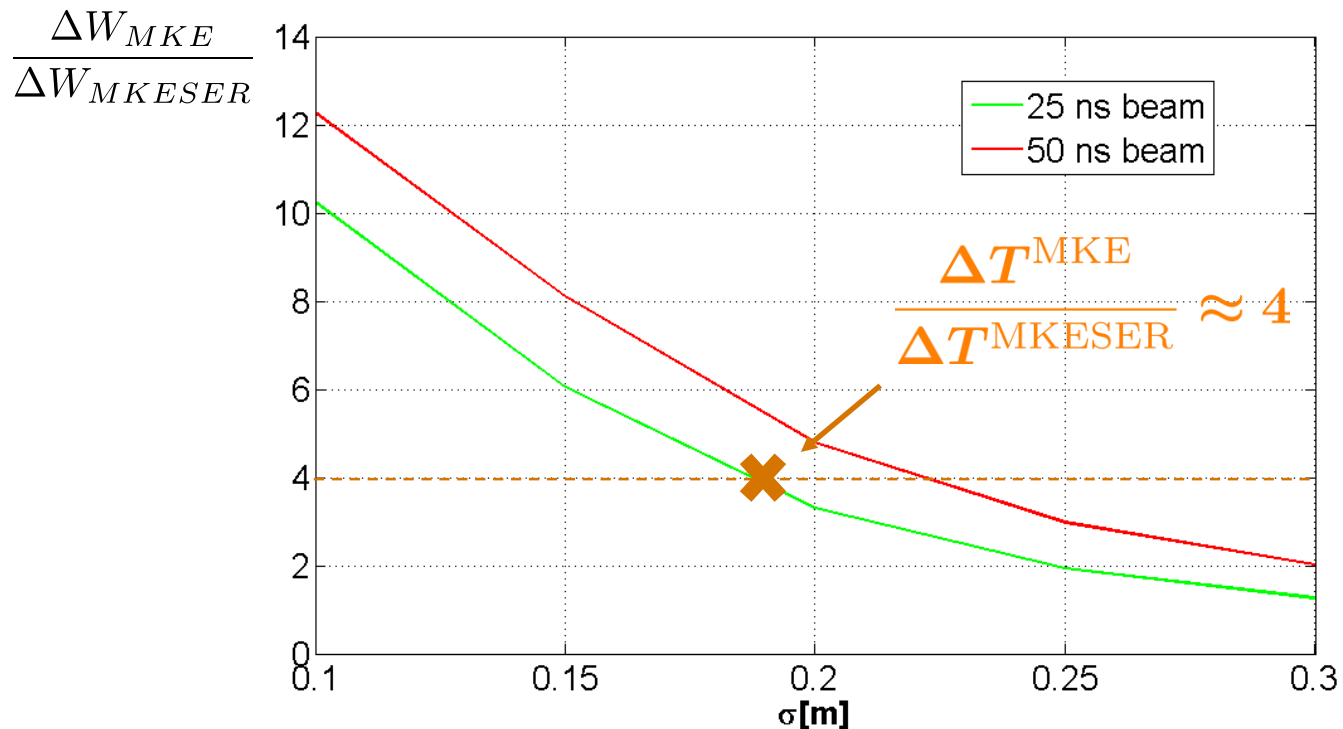

Application to the SPS extraction kickers

- This almost suppresses the impedance over the bunch spectrum
- It however introduces a low frequency peak, which needs to be kept far from beam spectral lines
- Expected up to 12-fold reduction of heat load, depending on bunch length and bunch spacing
 - Factor 4 for 25-ns LHC-type beam at 26 GeV → Experimentally measured!

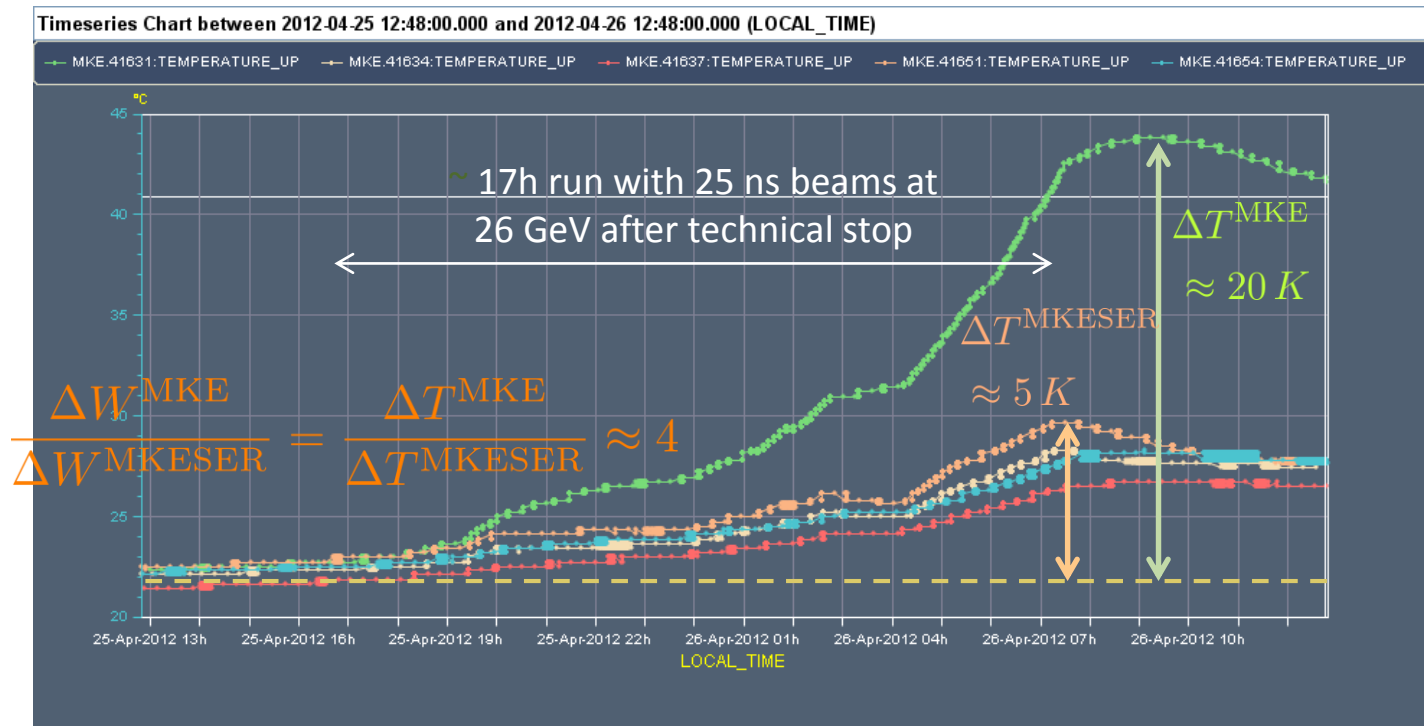

- We have further looked into the mechanism of energy loss and have seen the **impact of longitudinal impedances on machine elements** as these lead to **beam induced heating**.
- We have found that beam induced heating depends on the overlap of the **beam power spectrum** and the **impedance** of a given object.
- We have seen a **real world example** of the impact of an objects impedance on the beam induced heating.

Part 2: Multiparticle dynamics with wake fields – impact on machine elements and longitudinal beam dynamics

- General introduction to wake fields
- Longitudinal wake fields and the longitudinal wake function
- Energy loss – beam induced heating and stable phase shift
- Potential well distortion, bunch lengthening and microwave instability

Longitudinal wakes in beam dynamics

- The effect of each localised wake/impedance on each particle in a beam can be described as an energy kick
- The accelerator is made of many components, each giving a small kick to the beam particles, which drift freely in between

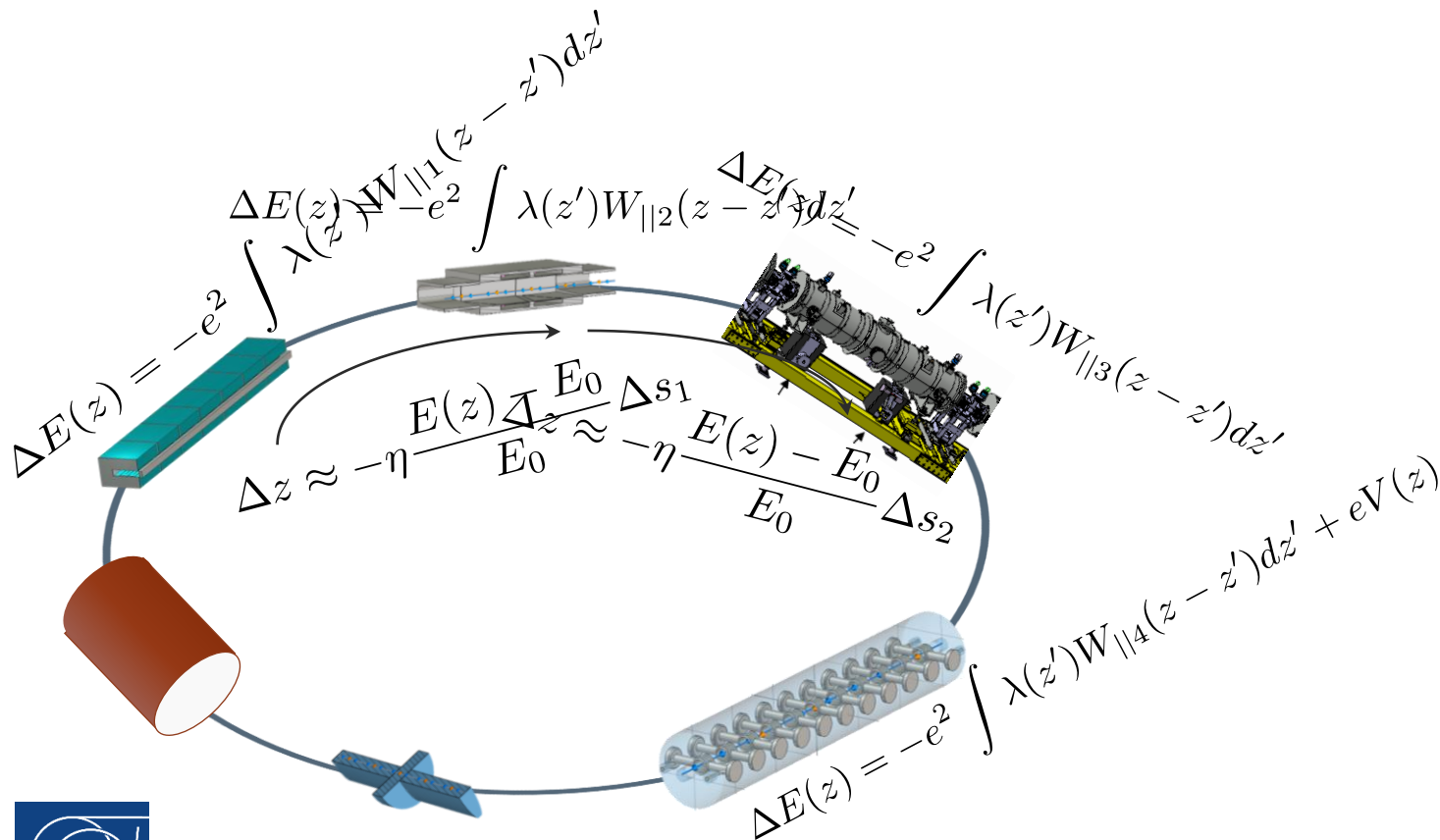

Longitudinal wakes in beam dynamics

- The effect of each localised wake/impedance on each particle in a beam can be described as an energy kick
- The accelerator is made of many components, each giving a small kick to the beam particles, which drift freely in between
- For simulations, the impedance is lumped in one place and kicks to beam particles are applied once per turn, with free drift over one turn

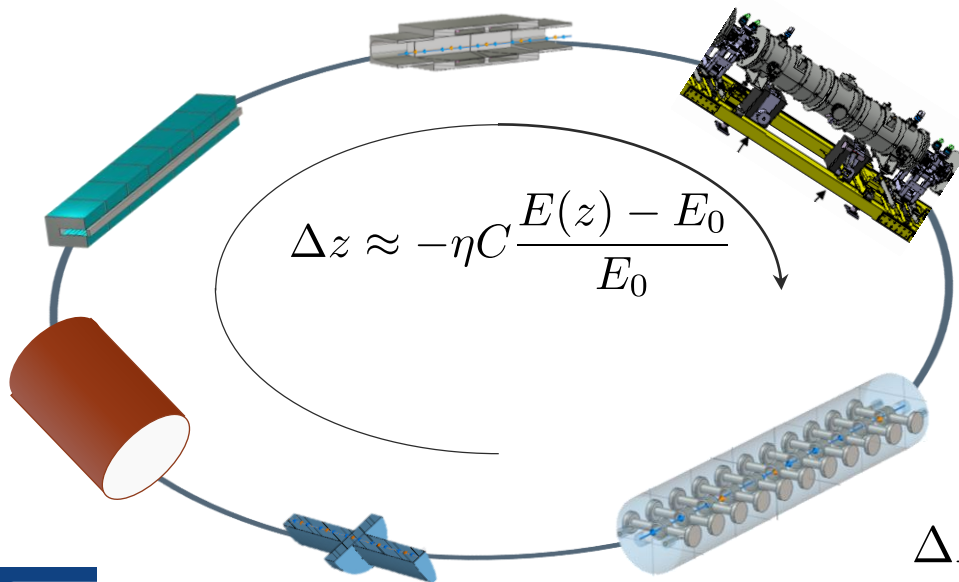

$$W_{||}^{\text{Ring}}(z) = \sum W_{||i}(z)$$

$$Z_{||}^{\text{Ring}}(\omega) = \sum Z_{||i}(\omega)$$

$$\Delta E(z) = -e^2 \int \lambda(z') W_{||}^{\text{Ring}}(z - z') dz'$$

- The effect of each localised wake/impedance on each particle in a beam can be described as an energy kick
- The accelerator is made of many components, each giving a small kick to the beam particles, which drift freely in between
- For simulations, the impedance is lumped in one place and kicks to beam particles are applied once per turn, with free drift over one turn
- For analytical calculations, both global impedance and RF are smeared over the ring

$$\begin{cases} \frac{dz}{ds} = -\eta\delta \\ \frac{d\delta}{ds} = \frac{e}{m_0\gamma cC} \left[V_{\text{rf}}(z) - e \sum_k \int \lambda(z' + kC) W_{\parallel}^{\text{Ring}}(z - z' - kC) dz' \right] \end{cases}$$

$$H = -\frac{1}{2}\eta\delta^2 + \frac{e}{\beta^2 EC} U_{\text{rf}}(z) + \frac{e^2}{\beta^2 EC} \int_{-\infty}^z dz'' \sum_k \int \lambda(z' + kC) W_{\parallel}^{\text{Ring}}(z'' - z' - kC) dz'$$

- For a bunch under the effect of longitudinal wake fields, two different regimes can be found:
 - Regime of **potential well distortion**, i.e. due to the impedance a new equilibrium distribution can be found for the bunch
 - Stable phase shift
 - Synchrotron frequency shift
 - Different matching (→ bunch lengthening for lepton machines)
 - Regime of **longitudinal instability**, i.e. no equilibrium distribution can be found under the effect of the impedance, a perturbation grows exponentially
 - Dipole mode instabilities
 - Coupled bunch instabilities
 - Microwave instability (longitudinal mode coupling)

- The **equilibrium distribution** in the presence of a longitudinal wake field can be found analytically. The (linearized) **longitudinal Hamiltonian** with longitudinal wake fields is given as:

$$H = -\frac{1}{2}\eta\delta^2 - \frac{1}{2\eta}\left(\frac{\omega_s}{\beta c}\right)^2 z^2 + \frac{e^2}{\beta^2 EC} \sum_k \int_0^z dz'' \int_{z''}^{\infty} dz' \lambda(z'+kC)W_{\parallel}(z''-z'-kC)$$

A simple Taylor expansion in z already qualitatively reveals some of the effects of the longitudinal wake fields onto the beam:

1. First order:
shift in the mean position (**stable phase shift**)
2. Second order:
change in bunch length accompanied by an (incoherent) **synchrotron tune shift**

- The equilibrium (matched) line charge density is then given by the self-consistency equation (**Haissinki equation**):

$$\lambda(z) = A \exp\left(-\frac{1}{2}\left(\frac{\omega_s z}{\eta\sigma_\delta\beta c}\right)^2 + \frac{e^2}{\eta\sigma_\delta^2\beta^2 EC} \sum_k \int_0^z dz'' \int_{z''}^{\infty} dz' \lambda(z'+kC)W_{\parallel}(z''-z'-kC)\right)$$

Bunch energy loss per turn and stable phase

- The **RF system compensates** for the energy loss by imparting a net acceleration to the bunch
- Therefore, the bunch readjusts to a **new equilibrium distribution** in the bucket and moves to an average synchronous angle $\Delta\Phi_s$

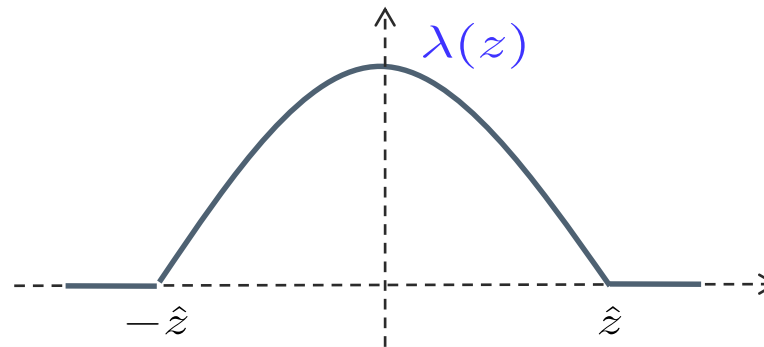

$$\sin \Delta\Phi_s = \frac{\Delta E_{\text{turn}}}{NeV_m} = -\frac{e\omega_0}{2\pi N V_m} \sum_{p=-\infty}^{\infty} \left| \hat{\lambda}(p\omega_0) \right|^2 \text{Re} (Z_{\parallel}(p\omega_0))$$

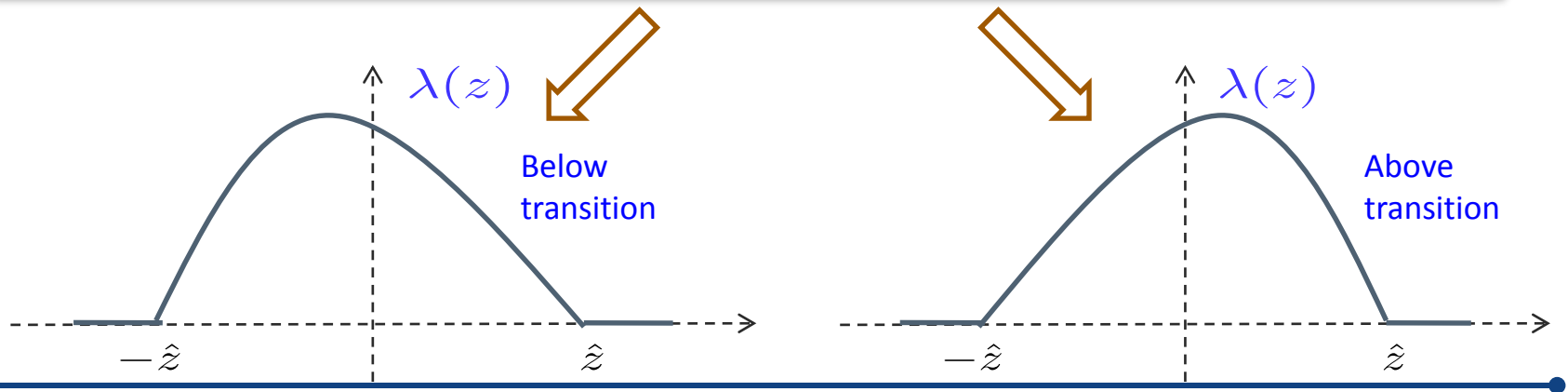

Bunch lengthening and μW instability

SPS ring
 $C = 6900 \text{ m}$
 $E_{\text{kin}} = 25 \text{ GeV}$

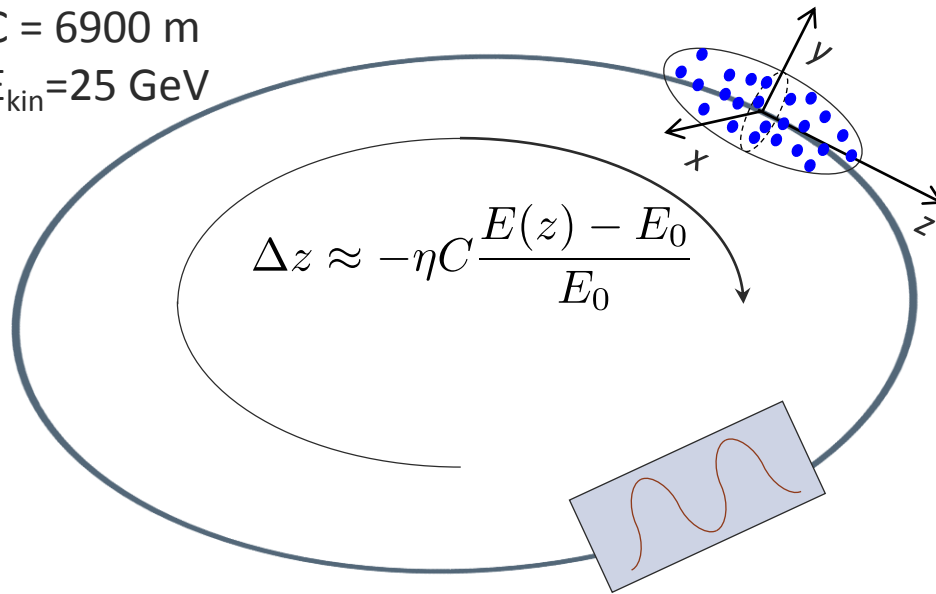

Single Gaussian bunch
 $\sigma_z = 0.2 \text{ m (0.67 ns)}$

Ring impedance modeled as
 broad band resonator with
 $\omega_r = 700 \text{ MHz}$
 $Q=1$
 $R_s =$

Single RF system
 $\omega_{\text{rf}} = 200 \text{ MHz}$
 $V_{\text{rf}}^{\text{max}} = 3 \text{ MV}$

$$\Delta E(z) = -e^2 \int \lambda(z') W_{||}^{\text{Res}}(z - z') dz' + eV_{\text{rf}}(z)$$

$$Z_{||}^{\text{Res}}(\omega) = \frac{R_{s||}}{1 + iQ \left(\frac{\omega}{\omega_r} - \frac{\omega_r}{\omega} \right)}$$

Bunch lengthening and μW instability

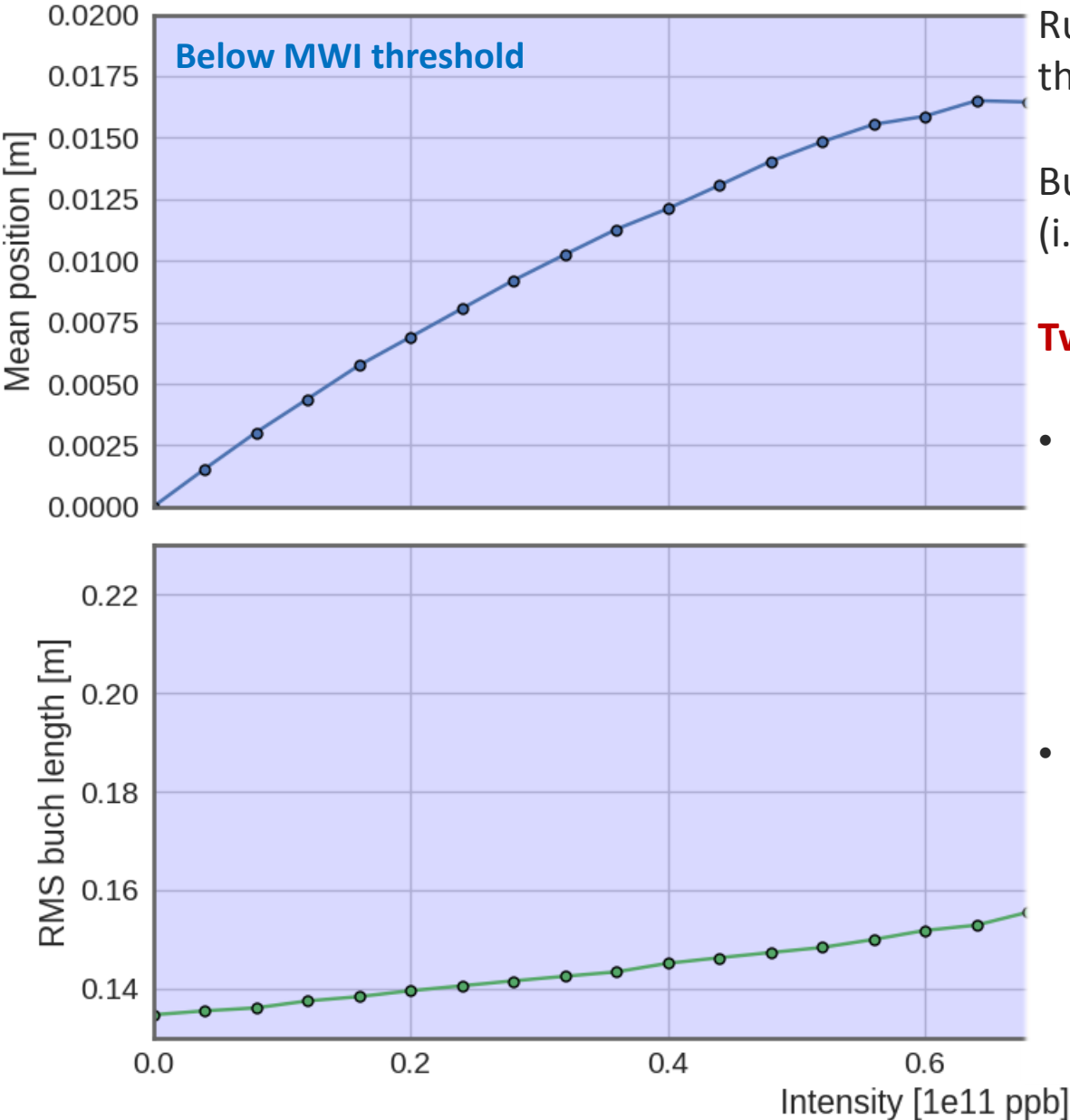

Running the numerical simulation for this case:

Bunch is matched at low intensity (i.e. without impedance)

Two regimes are found:

- Bunch lengthening/emittance blow up regime with roughly linear increase of the **synchronous phase** and **bunch length** with intensity
- Unstable regime (**turbulent bunch lengthening**)

Bunch lengthening and μW instability

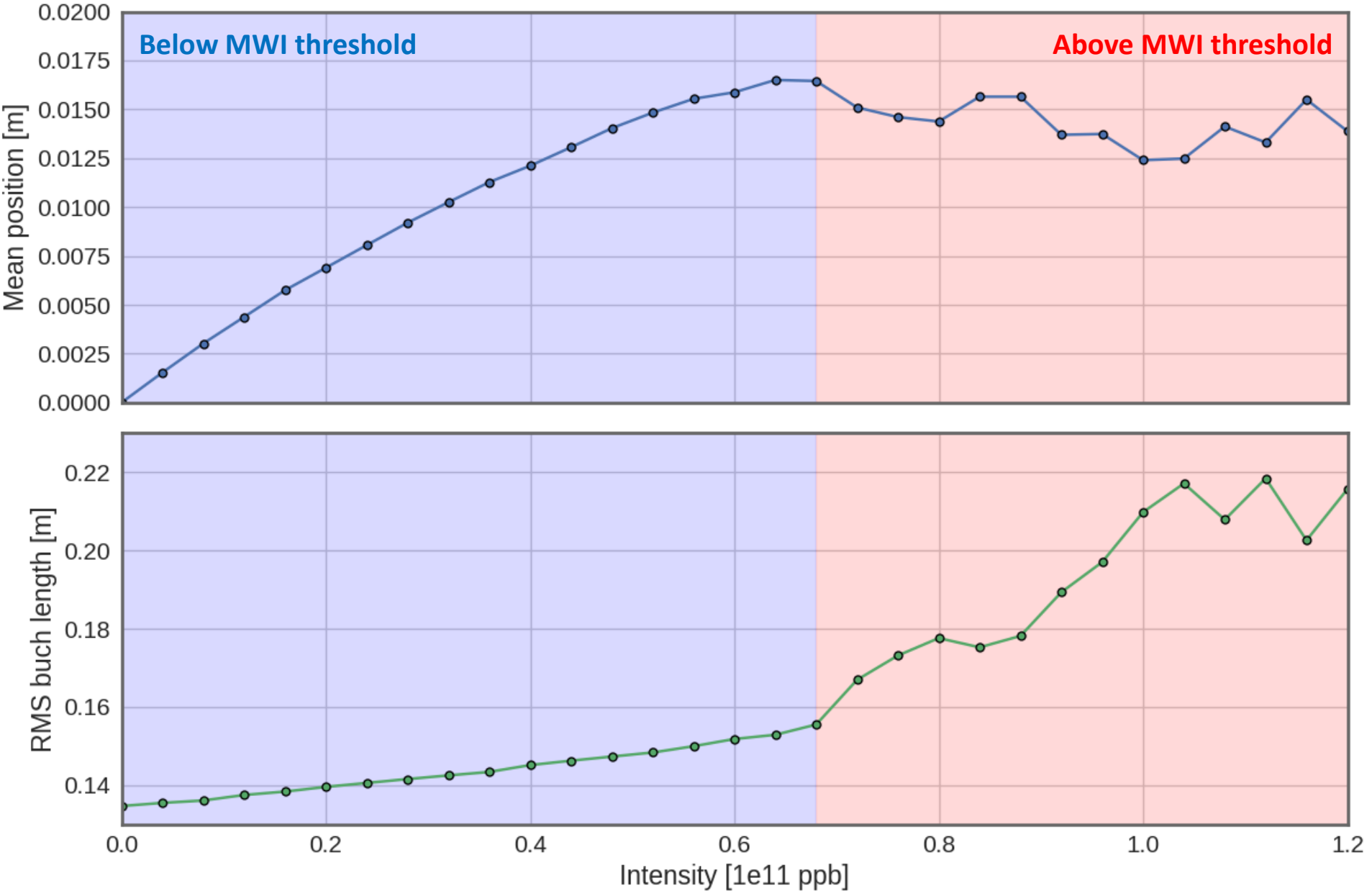

Bunch lengthening and μW instability

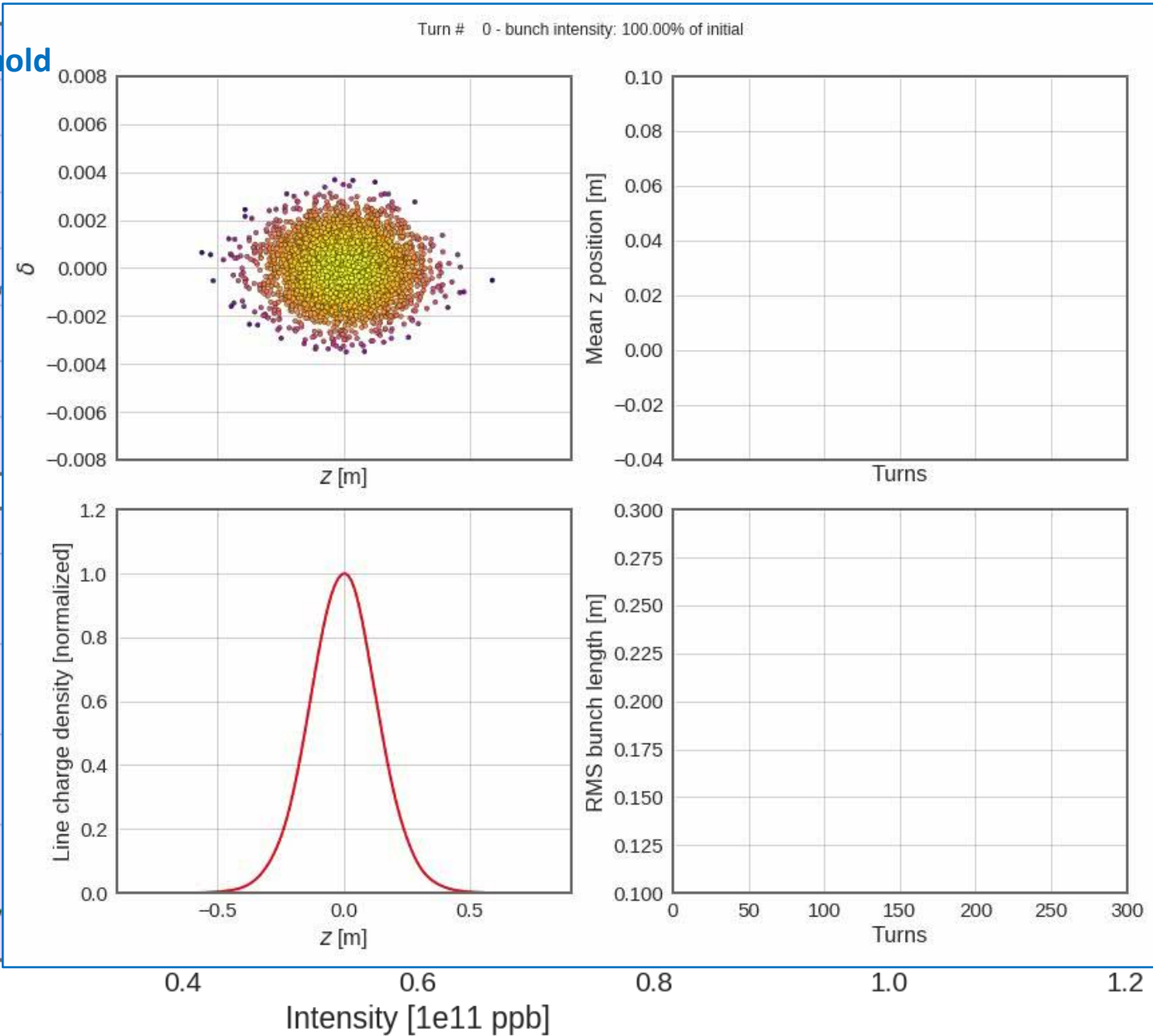
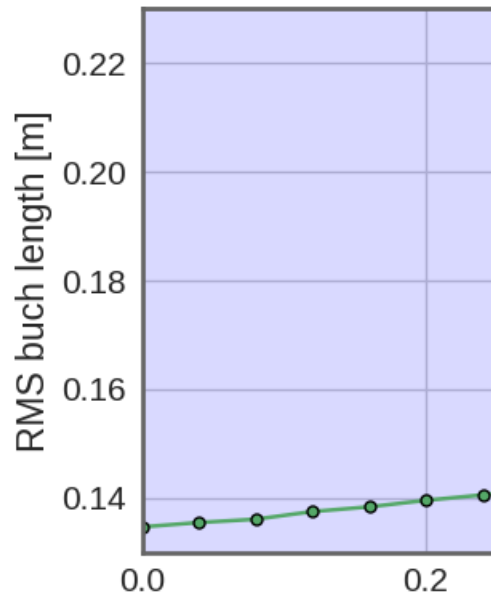
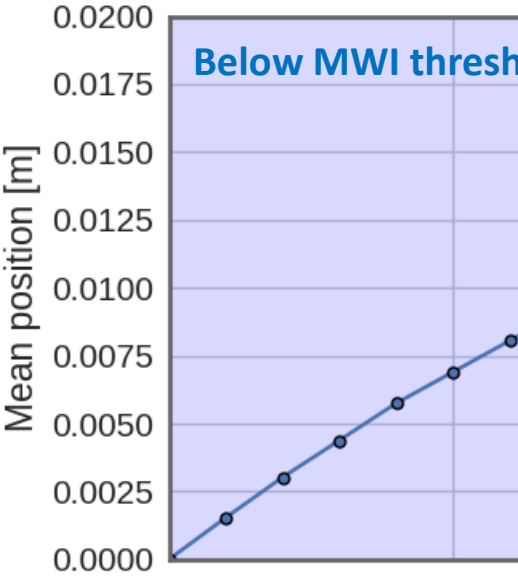

Bunch lengthening and μW instability

Turn # 0 - bunch intensity: 100.00% of initial

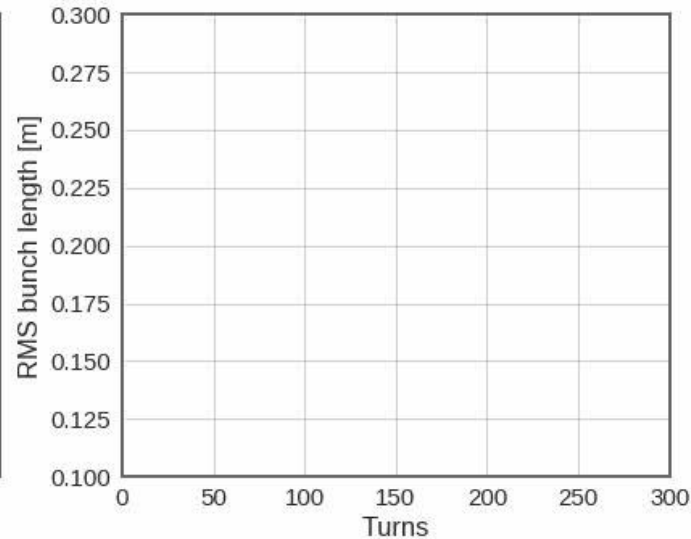
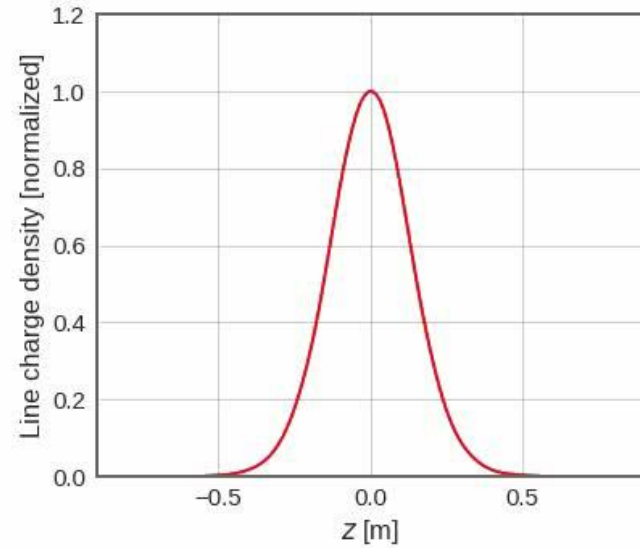
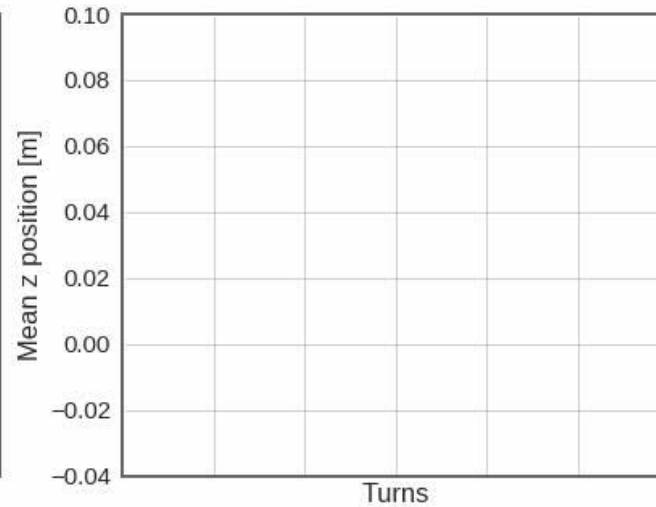
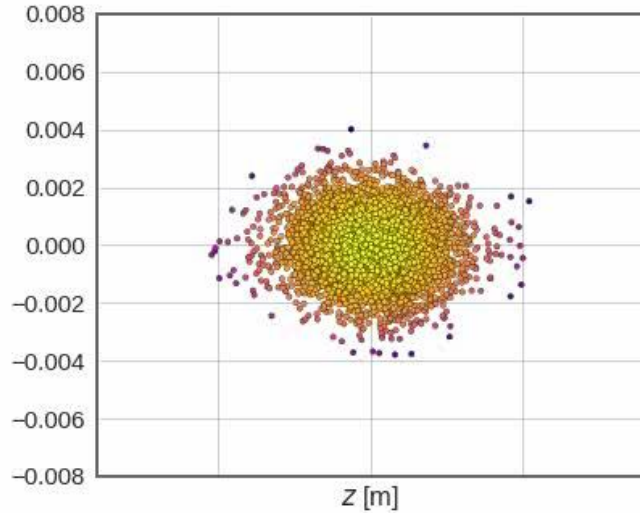

Above MWI threshold

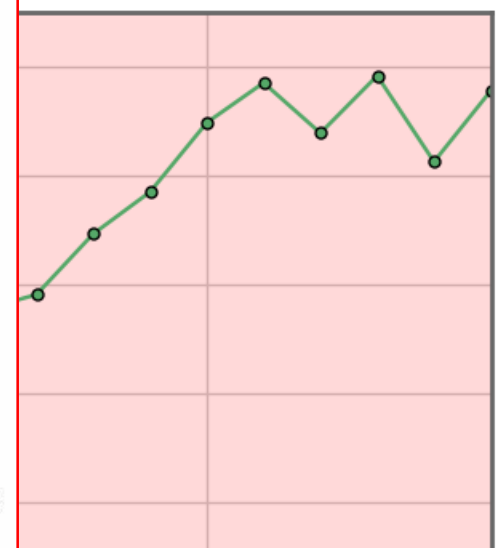
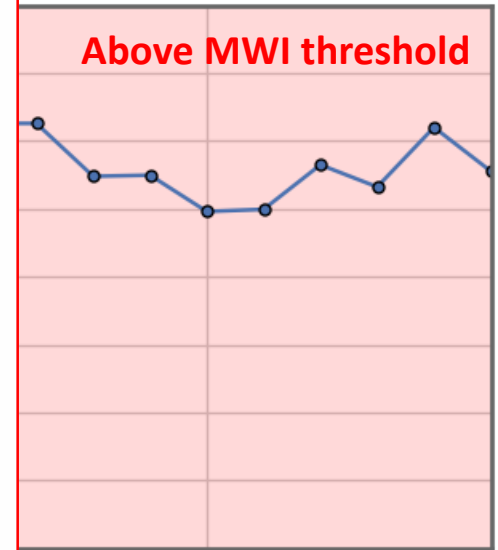

0.0

0.2

0.4

0.6

0.8

1.0

1.2

Intensity [1e11 ppb]

- We have **discussed longitudinal wake fields** and impedances and examples of their impact on both the machine as well as the beam.
- We have learned about **beam induced heating** and how it is related to the beam power spectrum and the machine impedance.
- We have discussed the effects of **potential well distortion** (stable phase and synchrotron tune shifts, bunch lengthening and shortening).
- We have seen one example of **longitudinal instability** (microwave).

Tomorrow Part 3

→ Transverse wake fields and impedances and their effects on the beam

End part 2



Backup - wakefields

- We have learned about the **impact of the longitudinal impedance on the beam**.
- We found the **Haissinki equation** and discussed the **potential well distortion** along with the **stable phase shift** and **synchrotron tune shift**.
- We looked at some generic wake fields and the **two regimes** of potential well distortion with **bunch lengthening** and its transition to the **microwave instability**.
- We will now look specifically at multi-turn wake fields and the phenomenon of **Robinson instability** and damping.

Part 2: Longitudinal wakefields – impact on machine elements and beam dynamics

- Longitudinal wake fields and the longitudinal wake function
- Energy loss – beam induced heating and stable phase shift
- Potential well distortion, bunch lengthening and microwave instability
- Robinson instability

The Robinson instability

- To illustrate the Robinson instability we will use some simplifications:
 - The bunch is **point-like** and feels an external linear force (i.e. it would execute linear synchrotron oscillations in absence of the wake forces)
 - The bunch additionally feels the effect of a **multi-turn wake**

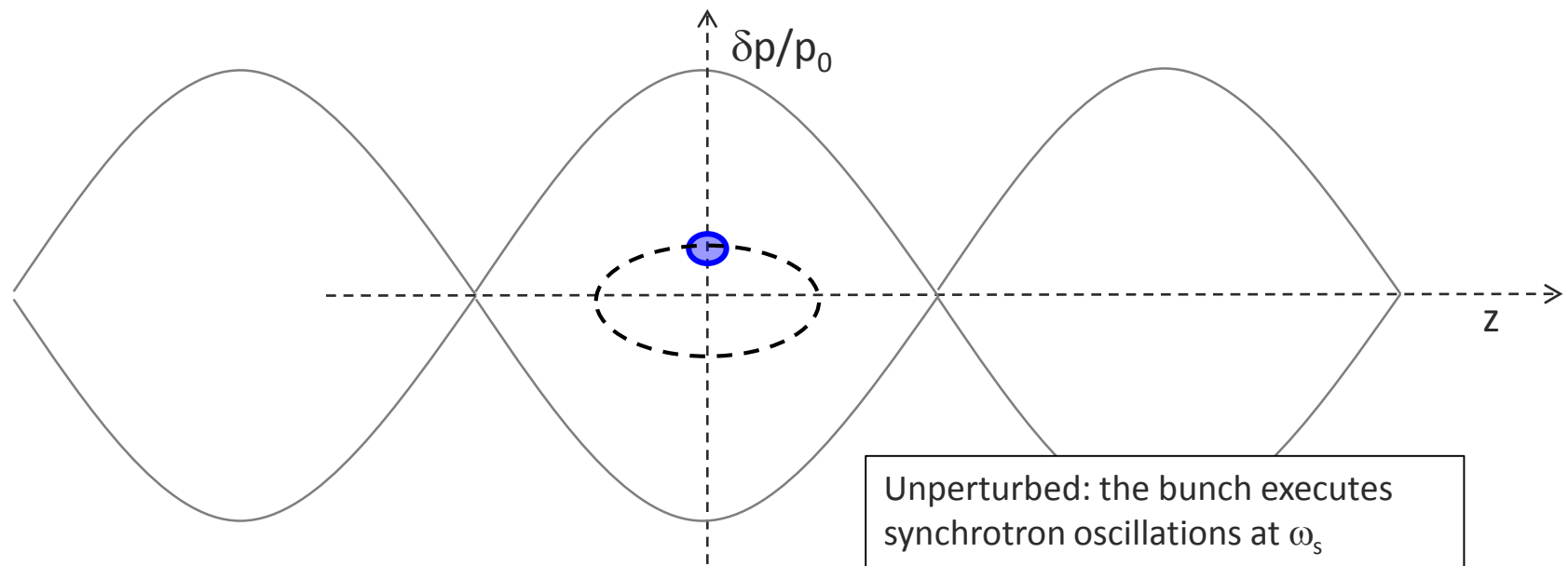

The Robinson instability

- To illustrate the Robinson instability we will use some simplifications:
 - The bunch is **point-like** and feels an external linear force (i.e. it would execute linear synchrotron oscillations in absence of the wake forces)
 - The bunch additionally feels the effect of a **multi-turn wake**

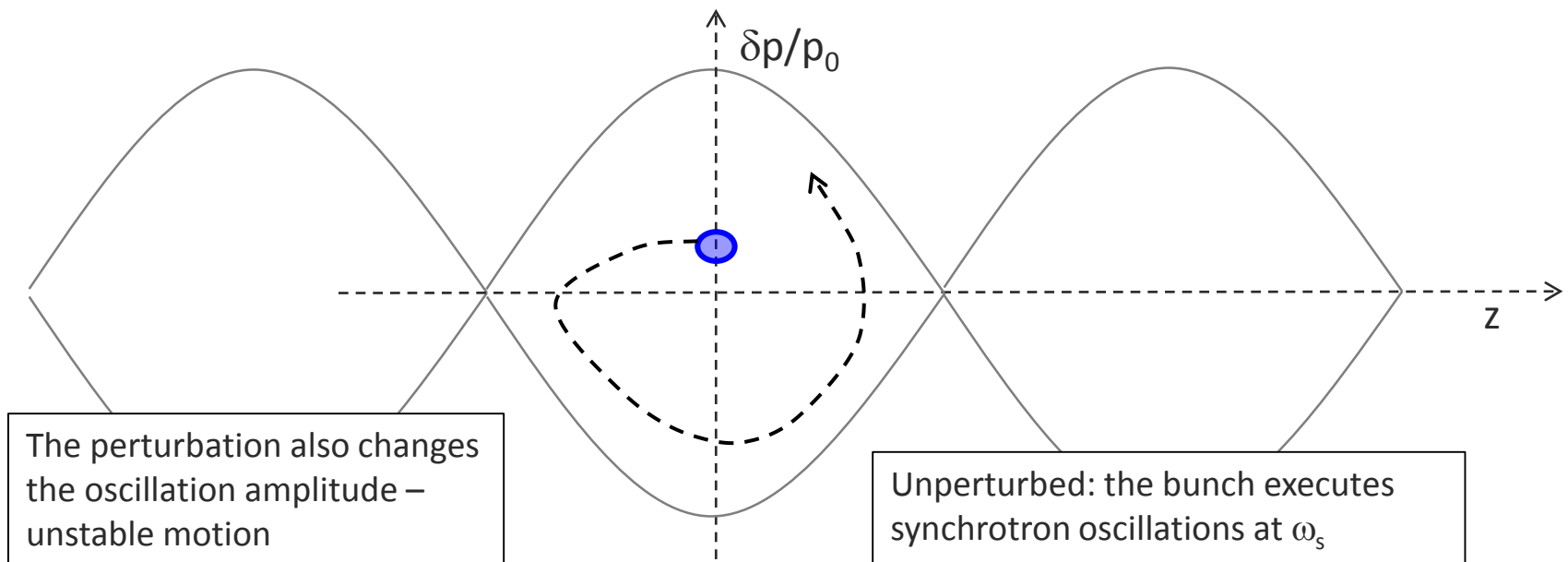

The Robinson instability

- To illustrate the Robinson instability we will use some simplifications:
 - The bunch is **point-like** and feels an external linear force (i.e. it would execute linear synchrotron oscillations in absence of the wake forces)
 - The bunch additionally feels the effect of a **multi-turn wake**

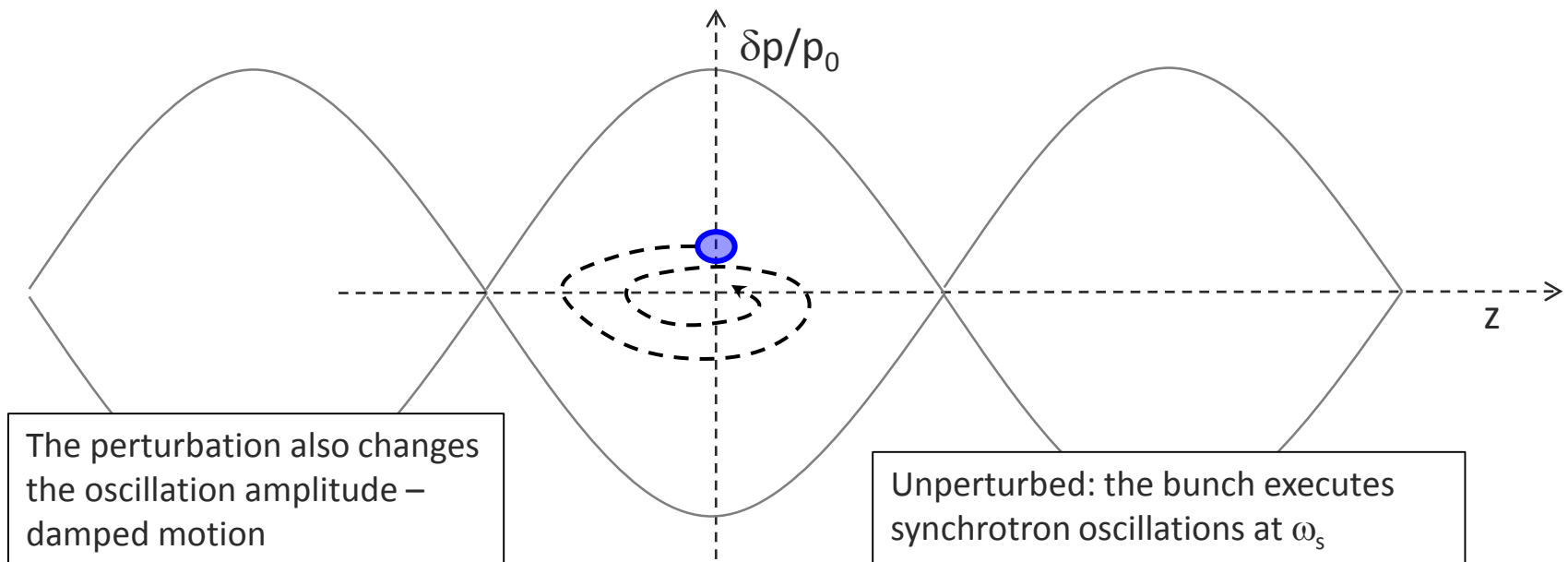

- To illustrate the Robinson instability we will use some simplifications:
 - The bunch is **point-like** and feels an external linear force (i.e. it would execute linear synchrotron oscillations in absence of the wake forces)
 - The bunch additionally feels the effect of a **multi-turn wake**
- Longitudinal Hamiltonian

$$\begin{aligned} H &= -\frac{1}{2}\eta\delta^2 - \frac{1}{2\eta}\left(\frac{\omega_s}{\beta c}\right)^2 z^2 + \frac{e^2}{\beta^2 EC} \sum_k \int_0^z dz'' \int_{z''}^{\infty} dz' \lambda(z' + kC) W_{\parallel}(z'' - z' - kC) \\ &= -\frac{1}{2}\eta\delta^2 - \frac{1}{2\eta}\left(\frac{\omega_s}{\beta c}\right)^2 z^2 + \frac{Ne^2}{\beta^2 EC} \sum_k \int_0^z dz'' W_{\parallel}(z(t) - z(t - kT_0) - kC) \end{aligned}$$

- Expansion of wake field (we assume that the wake can be linearized on the scale of a synchrotron oscillation)

$$\begin{aligned} W_{\parallel}(z(t) - z(t - kT_0) - kC) &\approx W_{\parallel}(kC) + W'_{\parallel}(kC) \left(z(t) - z(t - kT_0) \right) \\ &\approx W_{\parallel}(kC) + W'_{\parallel}(kC) kT_0 \frac{dz(t)}{dt} \end{aligned}$$

The Robinson instability

- The **first term** only contributes as a constant term in the solution of the equation of motion, i.e. the synchrotron oscillation will be executed around a certain z_0 and not around 0. This term represents the **stable phase shift** that compensates for the energy loss
 - The **second term** is a dynamic term introduced as a **“friction” term** in the equation of the oscillator, which can **lead to instability!**
-
- Equations of motion

$$\frac{d^2 z}{dt^2} + \omega_s^2 z^2 = \frac{Ne^2 \eta}{Cm_0 \gamma} \sum_{k=-\infty}^{\infty} \cancel{W_{\parallel}(kC)} + W'_{\parallel}(kC) kT_0 \frac{dz}{dt}$$

The Robinson instability

- The **first term** only contributes as a constant term in the solution of the equation of motion, i.e. the synchrotron oscillation will be executed around a certain z_0 and not around 0. This term represents the **stable phase shift** that compensates for the energy loss
- The **second term** is a dynamic term introduced as a **“friction” term** in the equation of the oscillator, which can **lead to instability!**

- Equations of motion

$$\frac{d^2 z}{dt^2} + \omega_s^2 z^2 = \frac{Ne^2 \eta}{Cm_0 \gamma} \sum_{k=-\infty}^{\infty} \cancel{W_{\parallel}(kC)} + W'_{\parallel}(kC) kT_0 \frac{dz}{dt}$$

- Ansatz

$$z(t) \propto \exp(-i\Omega t)$$

$$\frac{i}{C} \sum_{p=-\infty}^{\infty} \left(p\omega_0 Z_{\parallel}(p\omega_0) - (p\omega_0 + \Omega) Z_{\parallel}(p\omega_0 + \Omega) \right)$$

Expressed in terms of impedance

- Solution

$$(\Omega^2 - \omega_s^2) = -\frac{Ne^2 \eta}{Cm_0 \gamma} \sum_{k=-\infty}^{\infty} \left(1 - \exp(-ik\Omega T_0) \right) W'_{\parallel}(kC)$$

The Robinson instability

- We assume a small deviation from the synchrotron tune:
 - $\text{Re}(\Omega - \omega_s) \rightarrow$ **Synchrotron tune shift**
 - $\text{Im}(\Omega - \omega_s) \rightarrow$ **Growth/damping rate**, only depends on the dynamic term, if it is positive there is an instability!

- **Solution:**

$$\begin{aligned}(\Omega^2 - \omega_s^2) &= -\frac{iNe^2\eta}{C^2m_0\gamma} \sum_{p=-\infty}^{\infty} \left(p\omega_0 Z_{\parallel}(p\omega_0) - (p\omega_0 + \Omega) Z_{\parallel}(p\omega_0 + \Omega) \right) \\ &\approx 2\omega_s (\Omega - \omega_s)\end{aligned}$$

- **Tune shift:**

$$\begin{aligned}\Delta\omega_s = \text{Re}(\Omega - \omega_s) &= \frac{e^2}{m_0c^2} \frac{N\eta}{2\omega_s\gamma T_0^2} \\ &\quad \sum_{p=-\infty}^{\infty} \left(p\omega_0 \text{Im}[Z_{\parallel}](p\omega_0) - (p\omega_0 + \omega_s) \text{Im}[Z_{\parallel}](p\omega_0 + \omega_s) \right)\end{aligned}$$

- **Growth rate:**

$$\tau^{-1} = \text{Im}[\Omega - \omega_s] = \frac{e^2}{m_0c^2} \frac{N\eta}{2\omega_s\gamma T_0^2} \sum_{p=-\infty}^{\infty} \left((p\omega_0 + \omega_s) \text{Re}[Z_{\parallel}](p\omega_0 + \omega_s) \right)$$

The Robinson instability

- We assume the impedance to be peaked at a frequency ω_r close to $h\omega_0 \gg \omega_s$ (e.g. RF cavity fundamental mode or HOM)
- Only two dominant terms are left in the summation at the RHS of the equation for the growth rate
- Stability requires that η and $\Delta \text{Re} [Z_{\parallel}] (p\omega_0)$ have different signs
- **Solution:**

$$\begin{aligned} \tau^{-1} = \text{Im} (\Omega - \omega_s) &= \frac{e^2}{m_0 c^2} \frac{N\eta}{2\omega_s \gamma T_0^2} \sum_{p=-\infty}^{\infty} \left((p\omega_0 + \omega_s) \text{Re}(Z)_{\parallel}(p\omega_0 + \omega_s) \right) \\ &= \frac{e^2}{m_0 c^2} \frac{N\eta h\omega_0}{2\omega_s \gamma T_0^2} \underbrace{\left(\text{Re} [Z_{\parallel}] (h\omega_0 + \omega_s) - \text{Re} [Z_{\parallel}] (h\omega_0 - \omega_s) \right)}_{\Delta(\text{Re}[Z_{\parallel}](h\omega_0))} \end{aligned}$$

- **Stability criterion:**

$$\eta \cdot \Delta(\text{Re} [Z_{\parallel}] (h\omega_0)) < 0$$

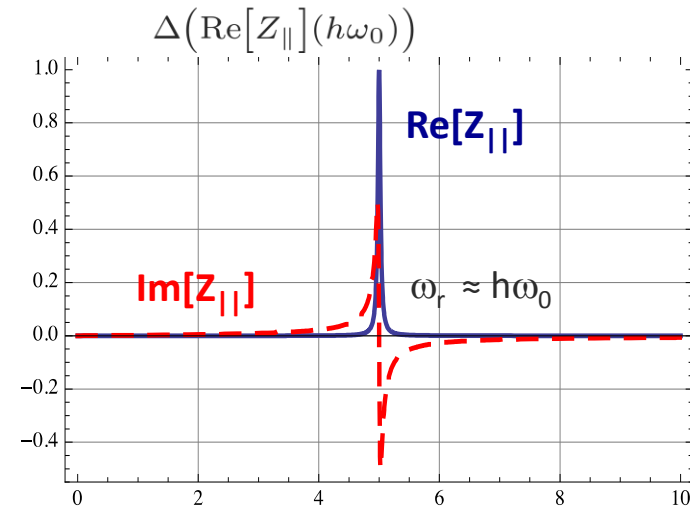

The Robinson instability

- **Stability criterion:** $\eta \cdot \Delta(\text{Re}[Z_{\parallel}](h\omega_0)) < 0$

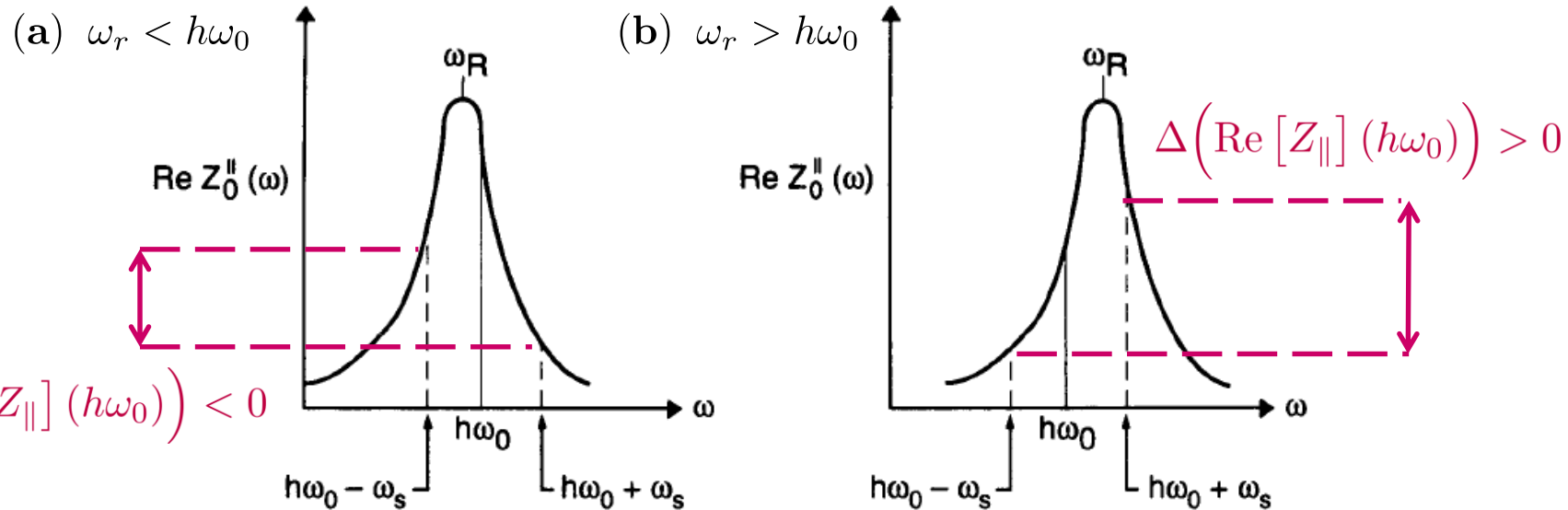
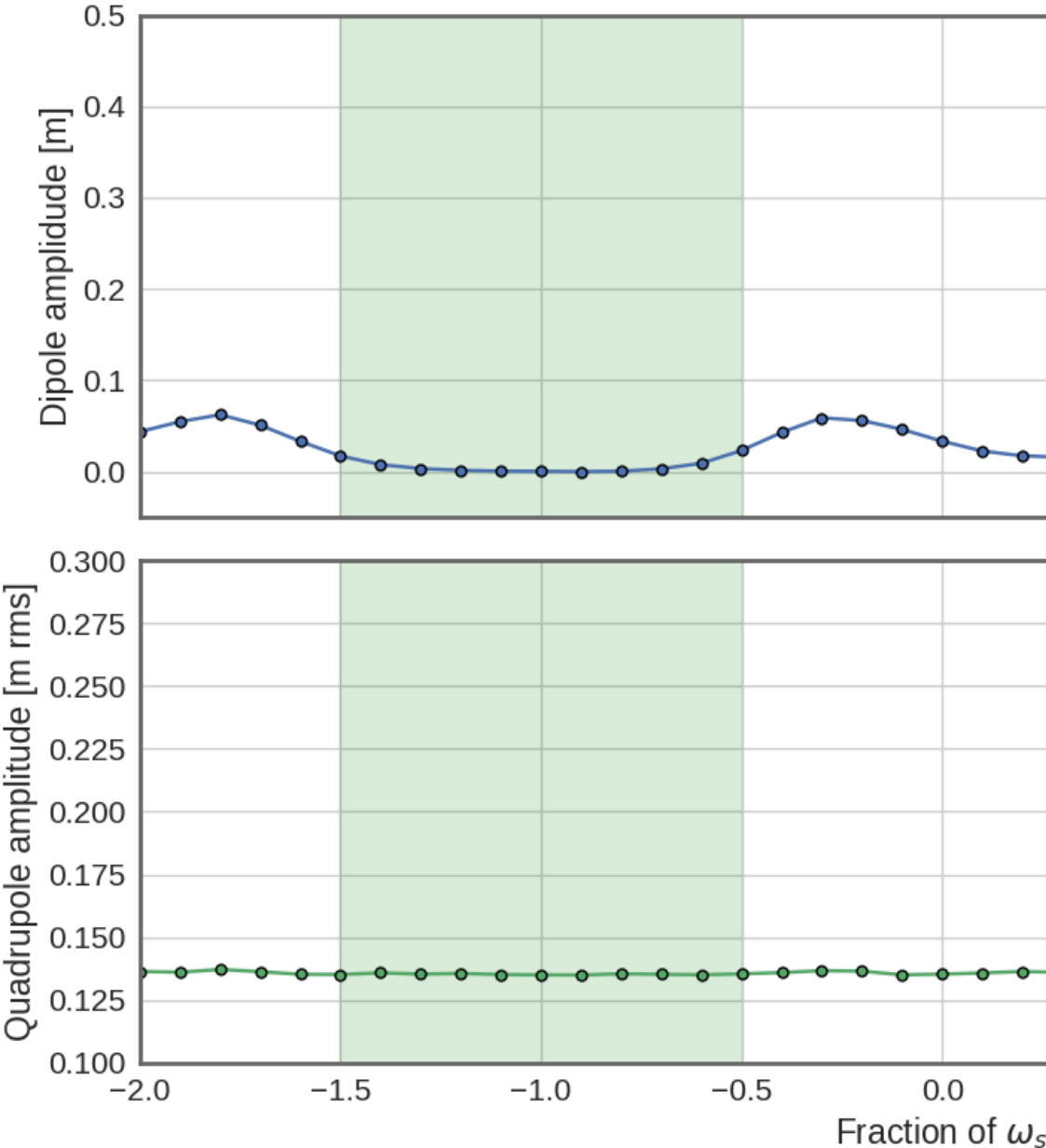

Figure 4.4. Illustration of the Robinson stability criterion. The rf fundamental mode is detuned so that ω_R is (a) slightly below $h\omega_0$ and (b) slightly above $h\omega_0$. (a) is Robinson damped above transition and antidamped below transition. (b) is antidamped above transition and damped below transition.

	$\omega_r < h\omega_0$	$\omega_r > h\omega_0$
Above transition ($\eta > 0$)	stable	unstable
Below transition ($\eta < 0$)	unstable	stable

Robinson damping and instability



Examples of numerical simulations – SPS bunch with **single narrow-band resonator** wake:

Initializing an otherwise matched bunch with a slight momentum error, **two regimes are found**:

- Regime of **Robinson damping** when the resonator is **detuned to $h\omega_0 - \omega_s$** . Initial dipole oscillations are damped.
- Regime of **Robinson instability** when the resonator is **detuned to $h\omega_0 + \omega_s$** . Initial dipole oscillations start to grow exponentially.

Robinson damping and instability

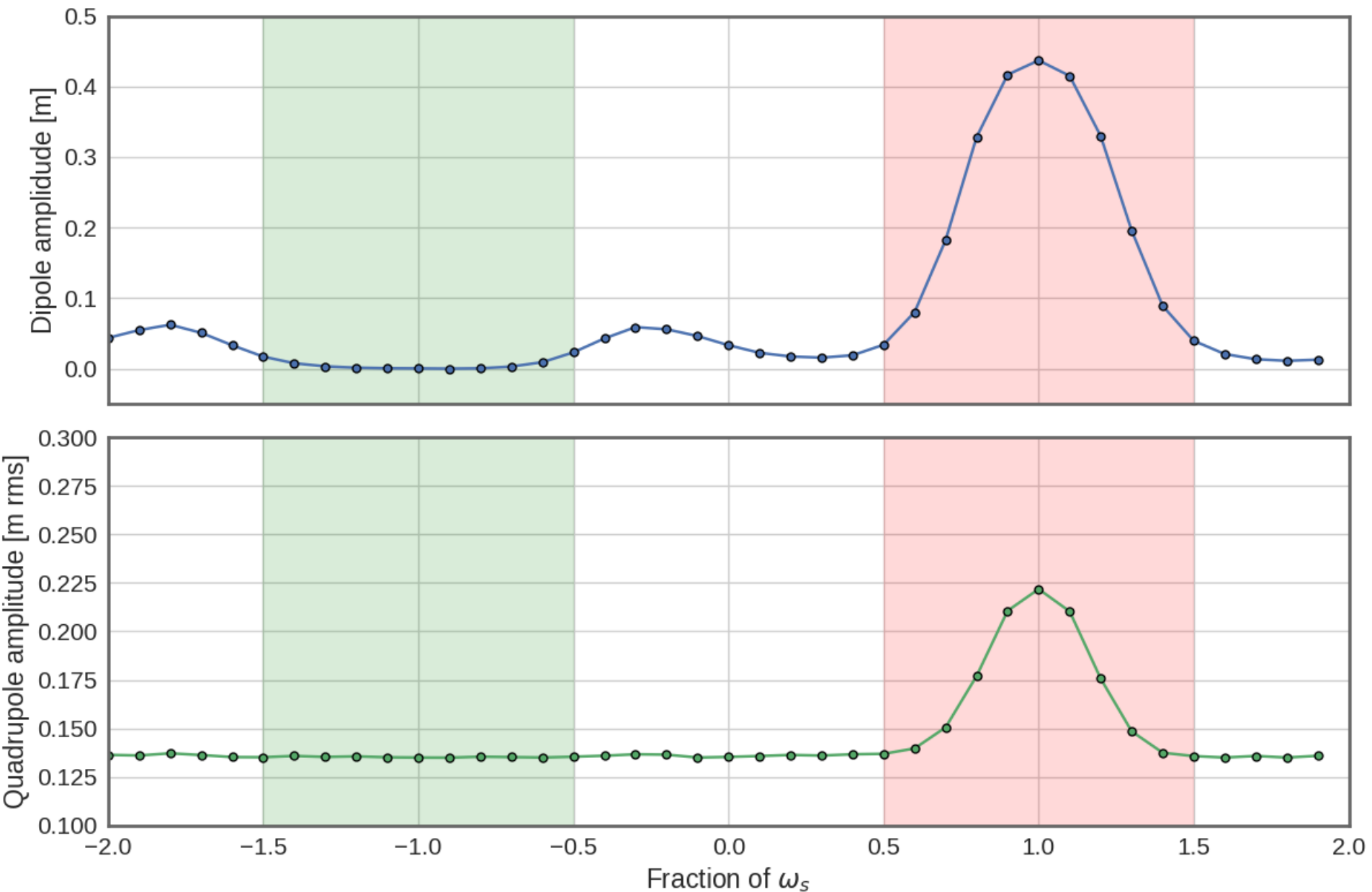

Robinson damping and instability

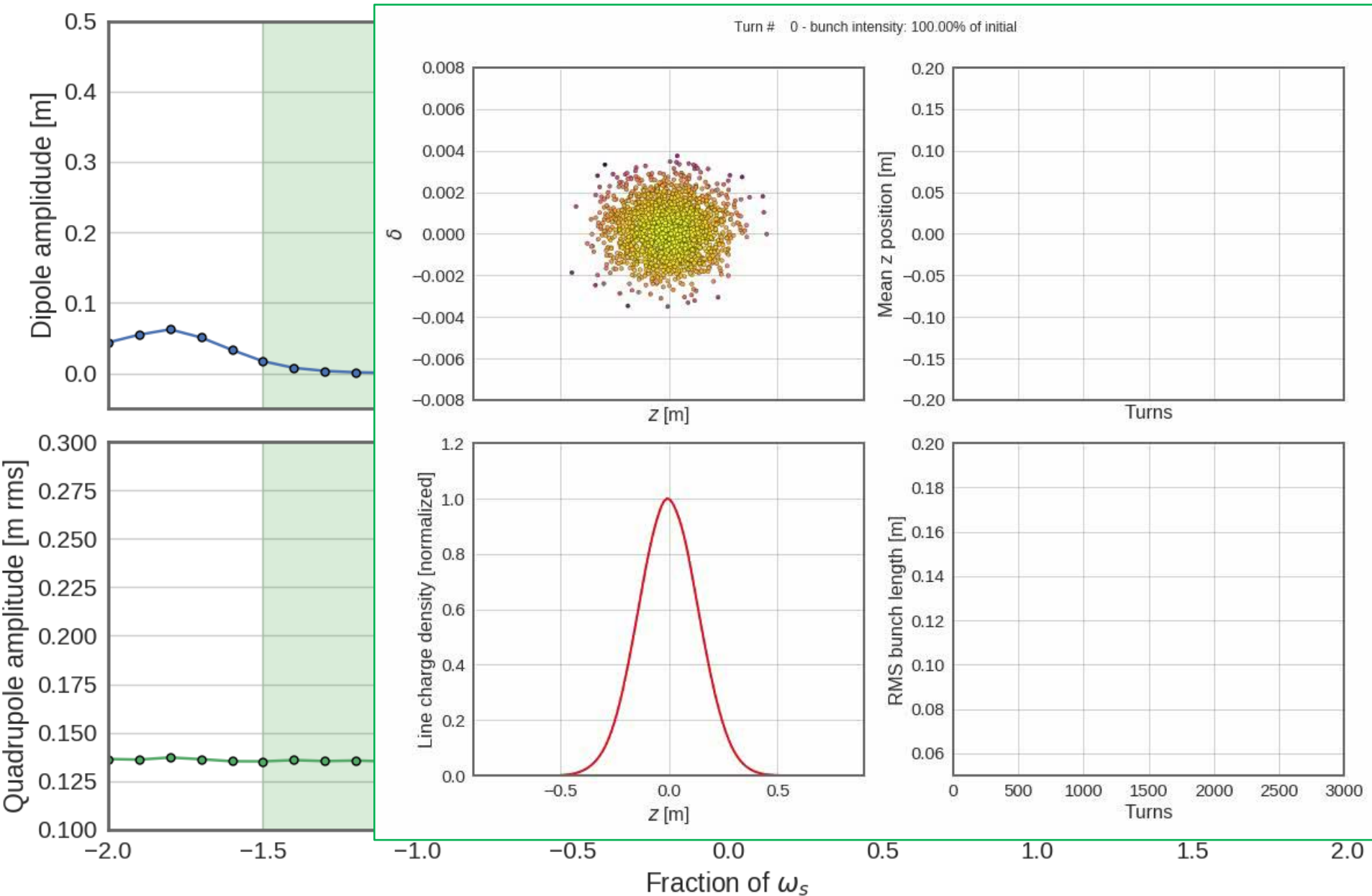

Robinson damping and instability

Turn # 0 - bunch intensity: 100.00% of initial

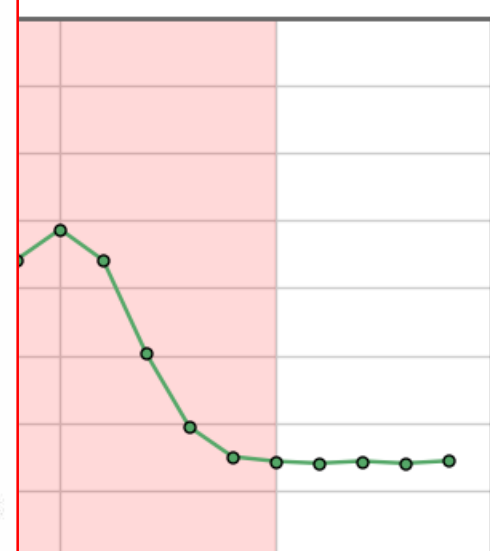
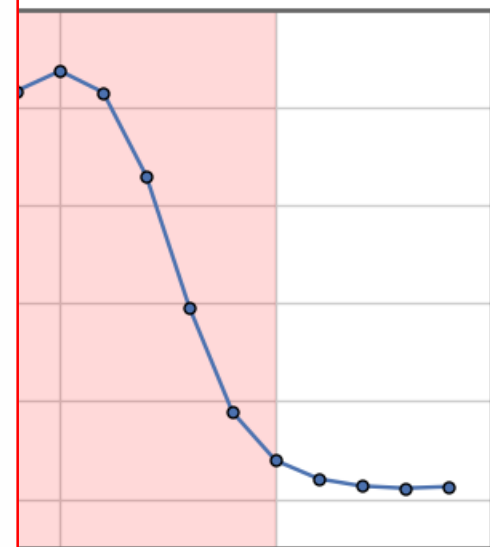
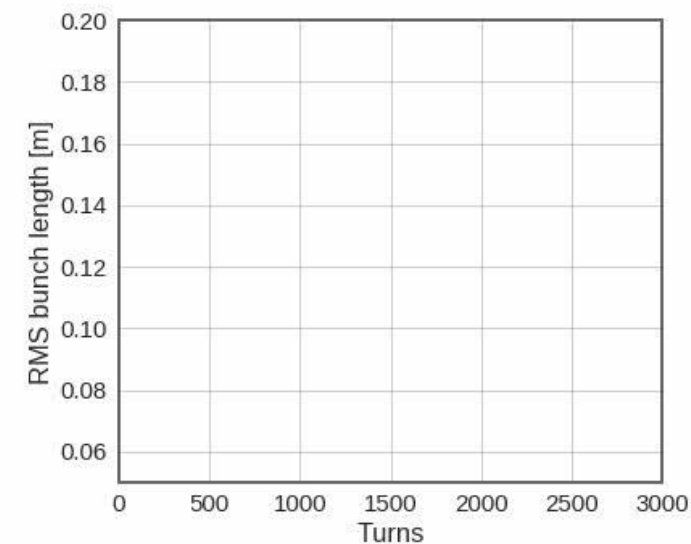
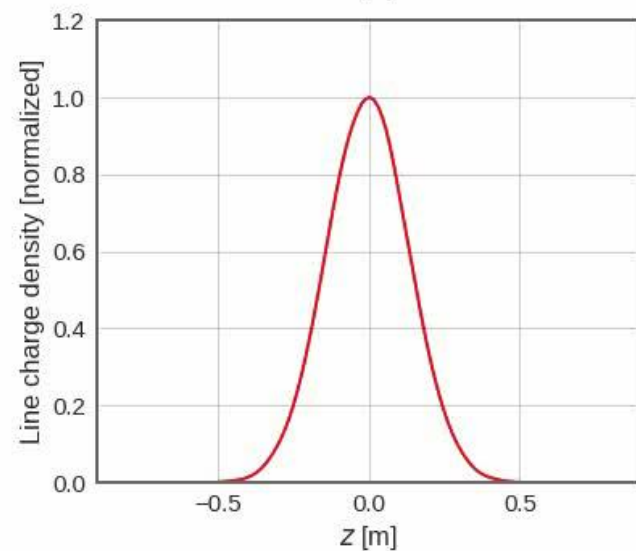
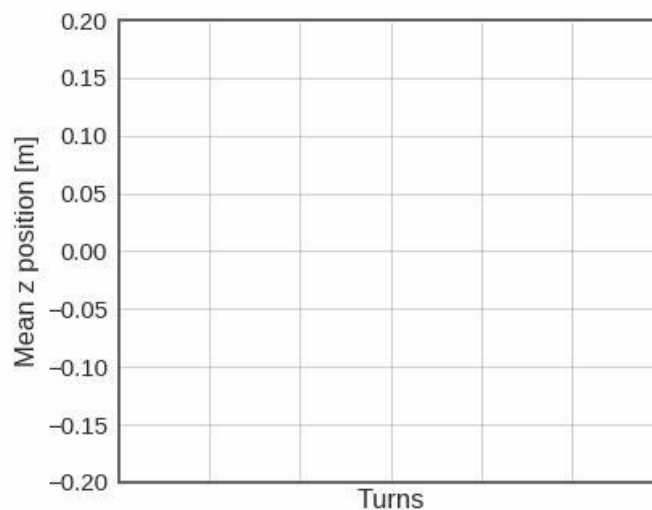
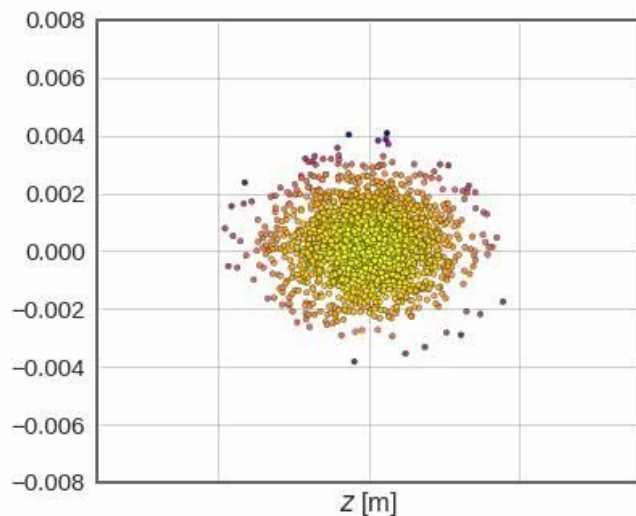

-2.0 -1.5 -1.0

-0.5 0.0 0.5

1.0 1.5 2.0

Fraction of ω_s

- The **Robinson instability** occurs for a single bunch under the action of a **multi-turn wake field**
 - It contains a term of coherent synchrotron tune shift which depends only on the imaginary part of the longitudinal impedance
 - It results into an unstable rigid bunch dipole oscillation where the growth rate depends on the real part of the longitudinal impedance
- Other **important collective effects** can affect a bunch in a beam – some of them of which we have also seen
 - Potential well distortion (resulting in synchronous phase shift, bunch lengthening or shortening, synchrotron tune shift/spread)
 - High intensity single bunch instabilities (e.g. microwave instability)
 - Coasting beam instabilities (e.g. negative mass instability)
 - Coupled bunch instabilities
- To be able to study these effects we would need to resort to a **more detailed description** of the bunch(es)
 - Vlasov equation (kinetic model)
 - Macroparticle simulations

Bunch energy loss per turn

- Single traversal of a bunch through an impedance source

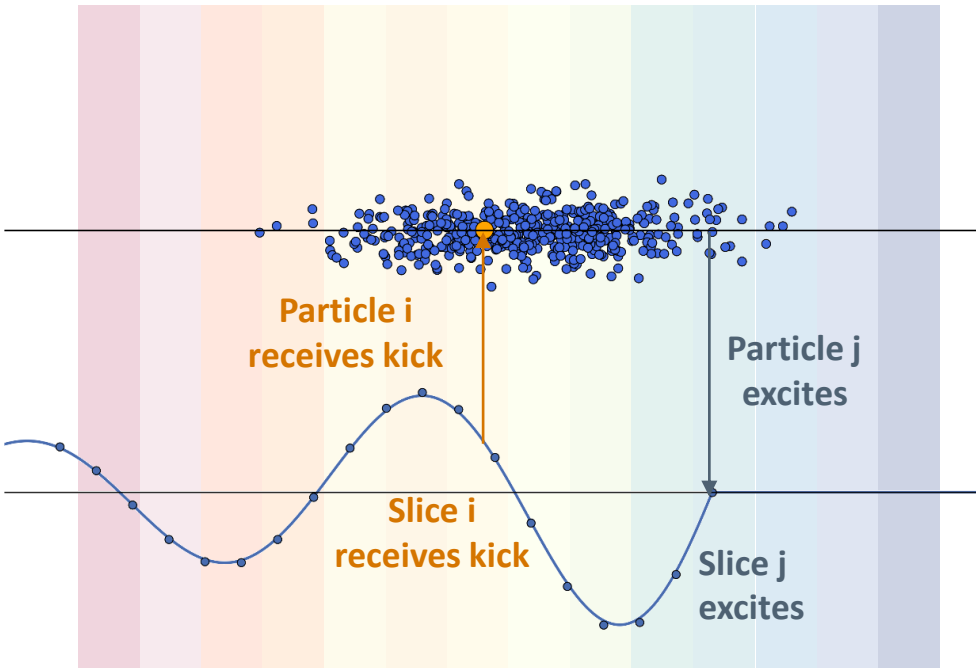

$$\Delta E_{ij} = -e^2 W_{||}(z_{ij})$$

$$\Delta E_{bunch} = -e^2 \sum_{j=1}^{N_b} \sum_{i=1}^{N_b} W_{||}(z_{ij})$$

$$\Delta E_{ij} = -e^2 N[j] N[i] W_{||}[(i - j) \Delta z]$$

$$\Delta E_i = -e^2 N[i] \sum_{j=0}^i N[j] W_{||}[(i - j) \Delta z]$$

Application to the LHC beam screen

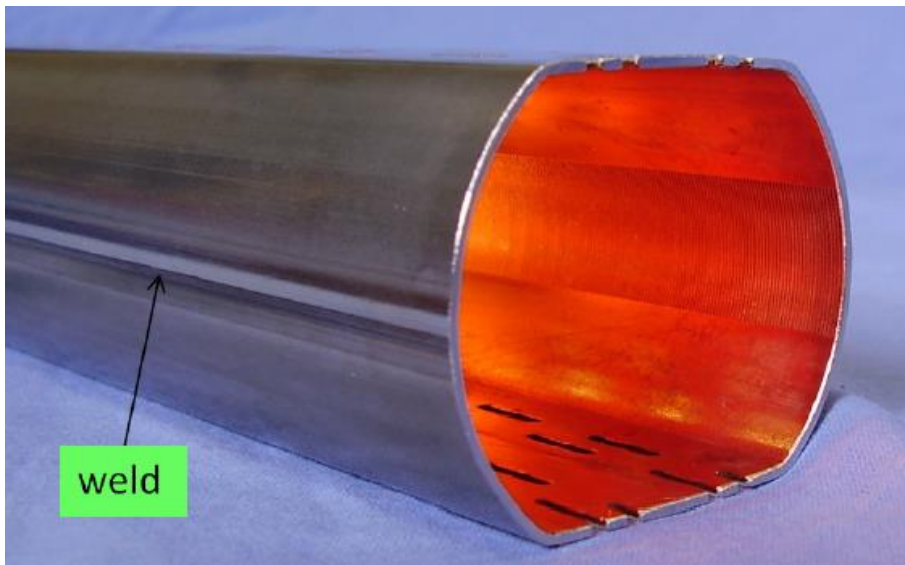
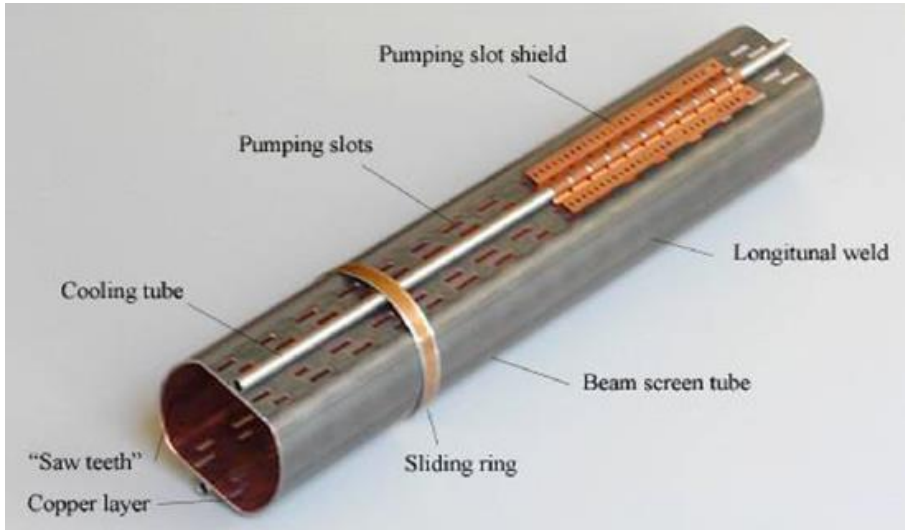

- All along the arcs and in other cold regions of the LHC, a beam screen is interposed between the beam and the cold bore
- The LHC beam screen is made of stainless steel with a layer of **few mm of co-laminated copper**
- Due to the production procedure, there is **a stainless steel weld** on one side of the beam screen that remains exposed to the beam.
- The screen has **holes for pumping** on top and bottom

Application to the LHC beam screen

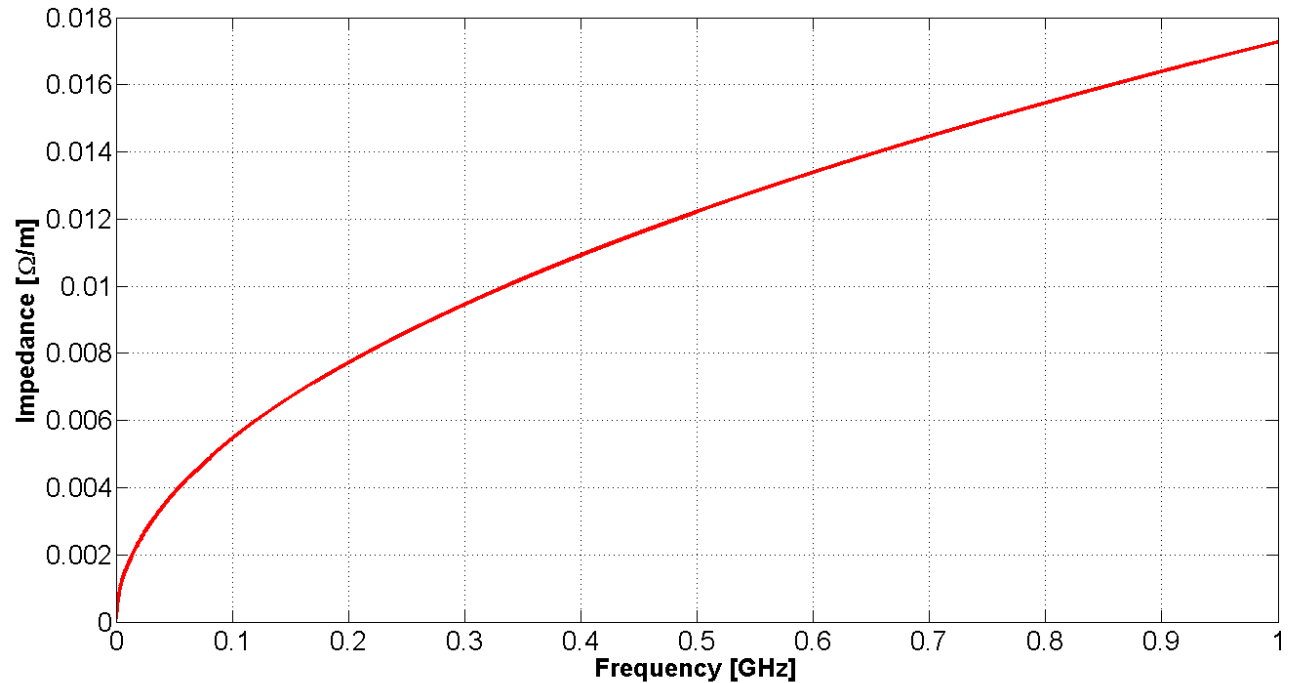
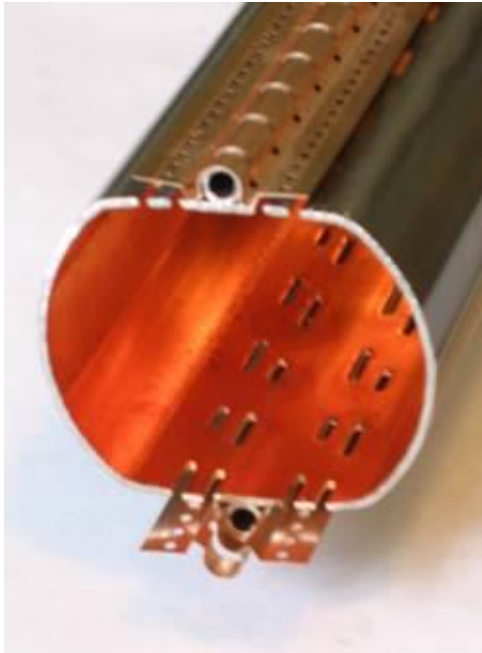

- The impedance model includes the **weld on one side of the beam screen**, which means a small longitudinal stripe of exposed StSt, as well as **the pumping holes**

Application to the LHC beam screen

fill 3286 started on Wed, 14 Nov 2012 00:14:24

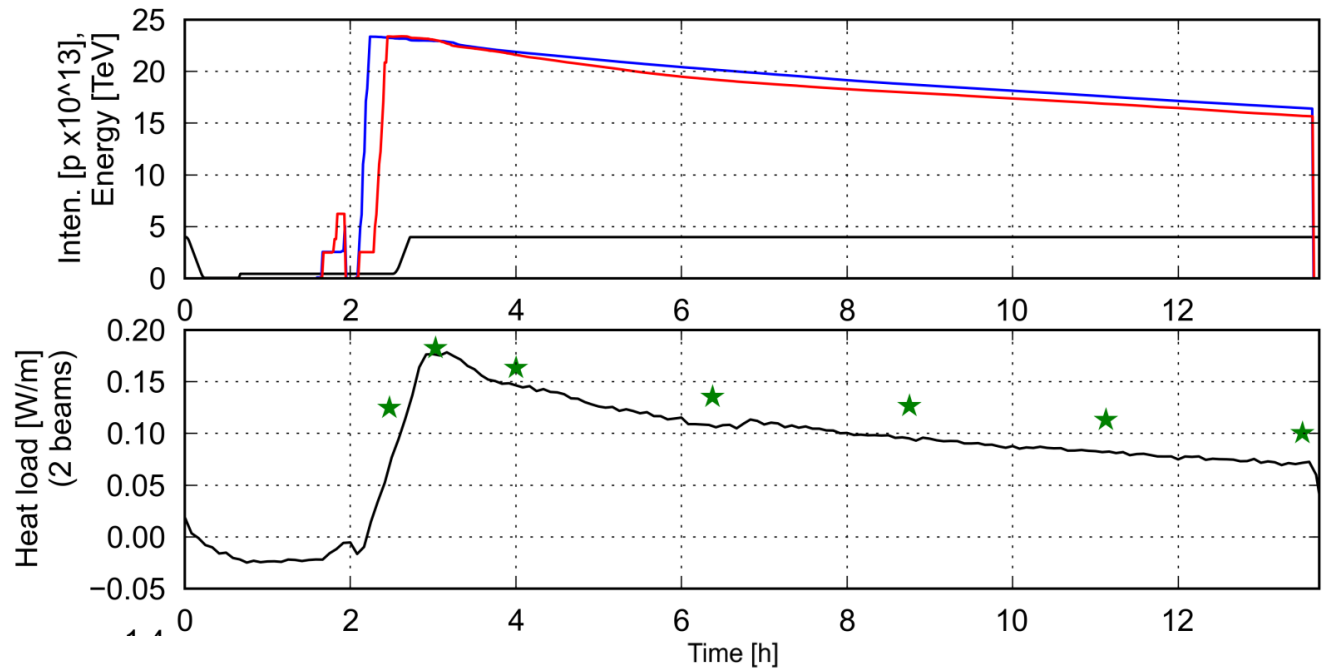
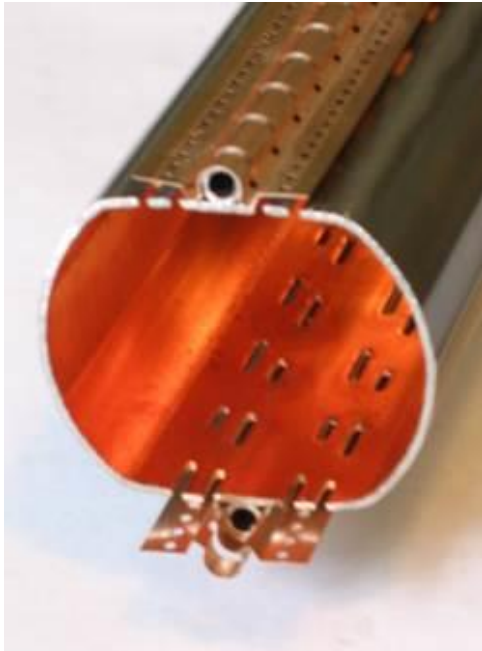

★ Estimation (impedance + synchrotron rad.)

— Heat load measurement from cryogenics

$$\Delta E_{\text{beam}} = \frac{e^2 \omega_0}{2\pi} \sum_{p=-\infty}^{\infty} |\tilde{\lambda}(p\omega_0)|^2 \text{Re} [Z_{||}(p\omega_0)] \cdot \left[\frac{1 - \cos\left(\frac{2\pi M p}{h}\right)}{1 - \cos\left(\frac{2\pi p}{h}\right)} \right]$$

- The heat dissipated on the beam screen **can be calculated for a beam made of bunches spaced by 50 ns** and compared to the measurement from cryogenics

Beam energy loss: a doublet beam

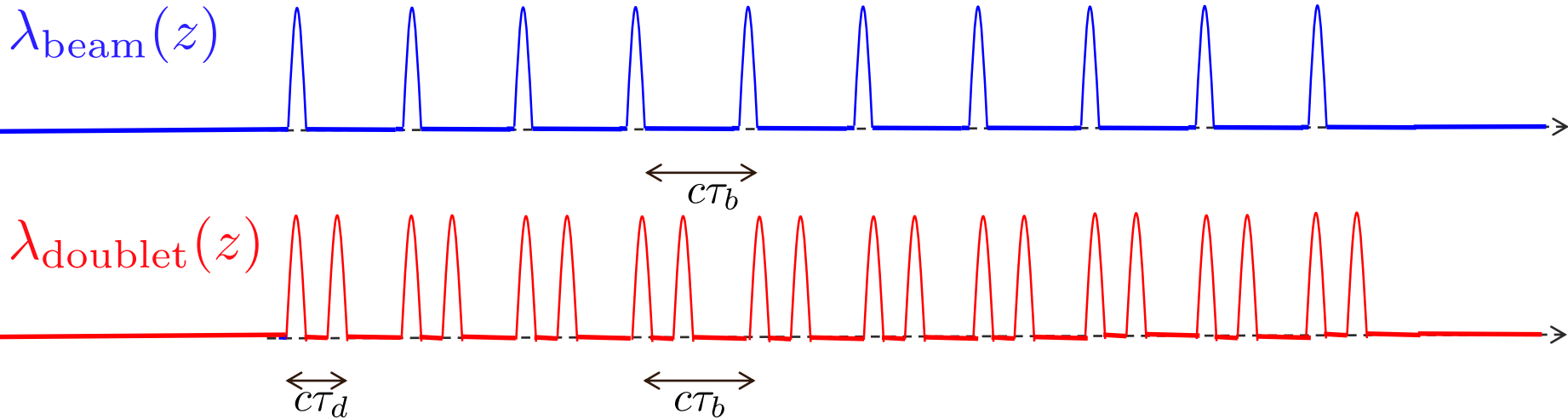

$$\Lambda_{\text{beam}}(\omega) \rightarrow \Lambda_{\text{doublet}}(\omega) = \Lambda_{\text{beam}}(\omega) [1 + \exp(-i\omega\tau_d)]$$



$$\Delta E_{\text{doublet}} = \frac{2e^2\omega_0}{\pi} \sum_{p=-\infty}^{\infty} |\Lambda_{\text{beam}}(p\omega_0)|^2 \cos^2\left(\frac{p\omega_0\tau_d}{2}\right) \text{Re} [Z_{\parallel}(p\omega_0)]$$

N.B. in this example the doublet has double total intensity than single beam

Beam energy loss: a doublet beam

- No additional impedance energy loss is expected with the doublet beam with respect to nominal beam for same total intensity
 - Beam power spectrum is modulated with \cos^2 function and lines are weakened by this modulation
 - For higher doublet intensity, global effect depends on the impedance spectrum
 - Example \rightarrow LHC injection beam stopper (TDI)

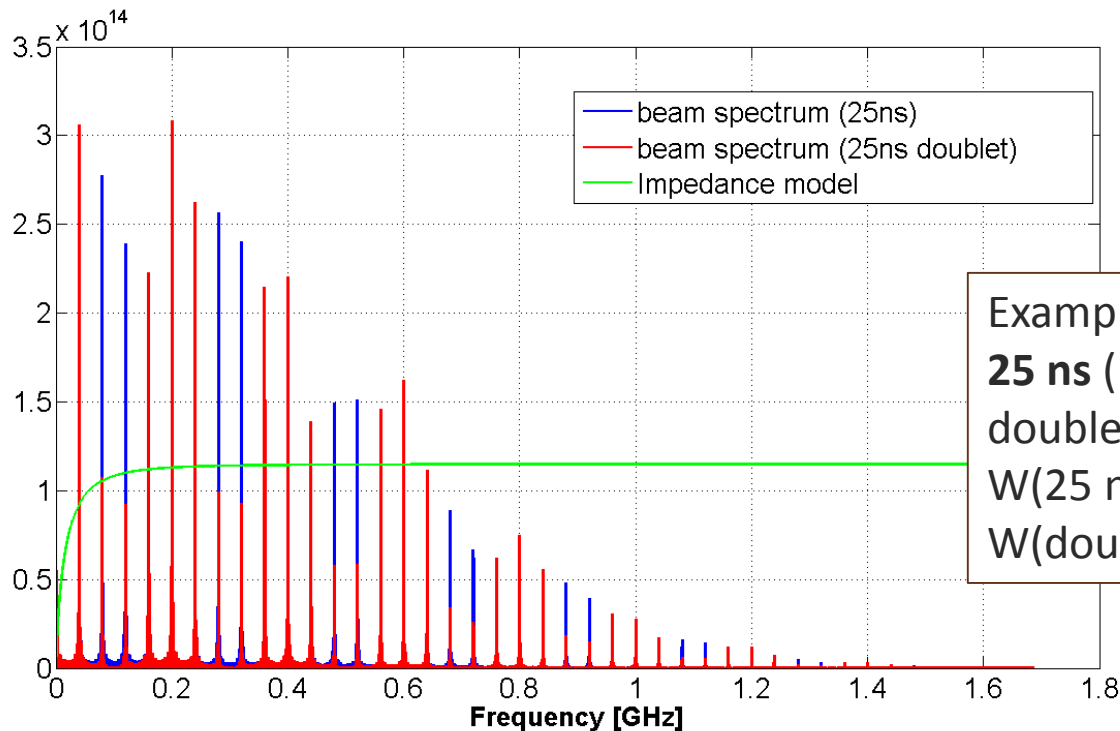

Example for LHC beam in TDI:
25 ns (1.2×10^{11} p/b) vs. **20+5 ns**
 doublet (1.5×10^{11} p/doublet)
 $W(25 \text{ ns}) = 456 \text{ W}$
 $W(\text{doublet}) = 338 \text{ W}$

Beam energy loss: collider's common chamber

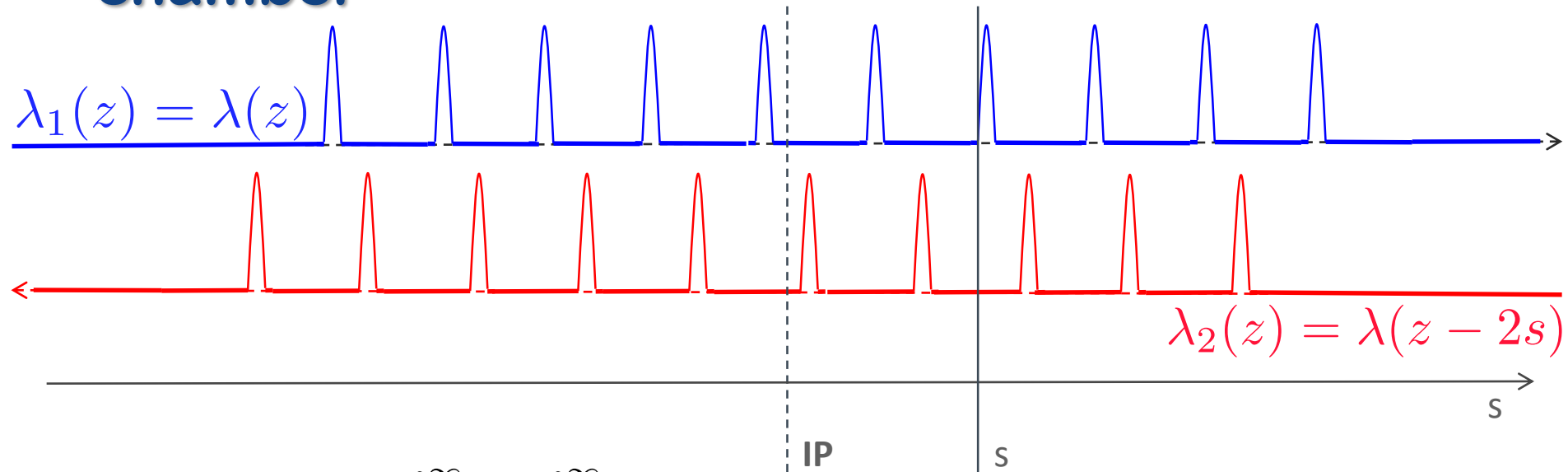

$$\Delta E_{\text{beam1}}(s) = e^2 \int_{-\infty}^{\infty} \lambda(z) \int_{-\infty}^{\infty} [\lambda(z') W_{\parallel b1}(z - z') - \lambda(z' - 2s) W_{\parallel b2}(z - z')] dz' dz$$

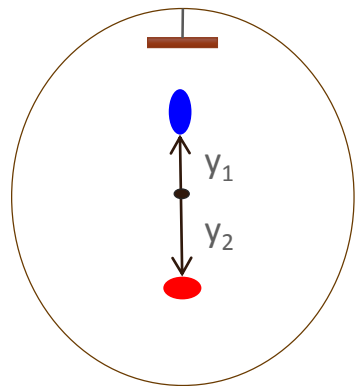

$$W_{\parallel b1}(z) = W_{\parallel}^{(0)}(z) + W_{\parallel}^{(1d)}(z)y_1 + W_{\parallel}^{(1q)}(z)y_1$$

$$W_{\parallel b2}(z) = W_{\parallel}^{(0)}(z) + W_{\parallel}^{(1d)}(z)y_2 + W_{\parallel}^{(1q)}(z)y_1$$

$$\text{with } W_{\parallel}^{1d}(z) = W_{\parallel}^{1q}(z)$$

Beam energy loss: collider's common chamber

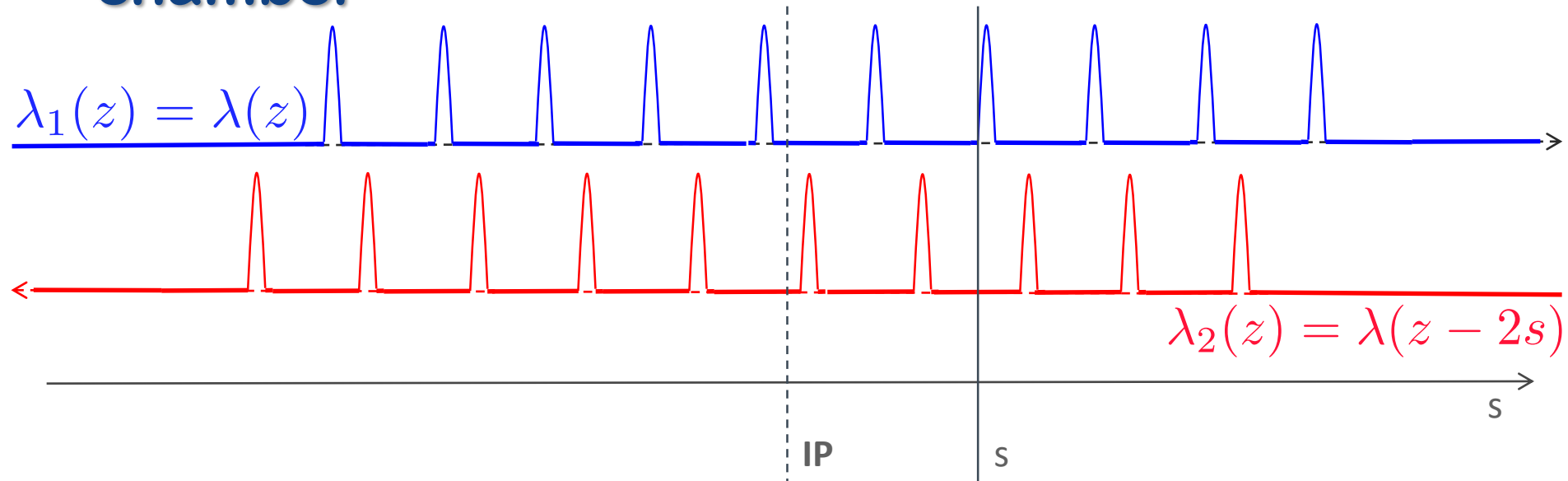

$$W_{||}^{1d}(z), W_{||}^{1q}(z) \xleftrightarrow{\mathcal{F}} Z_{||}^1(\omega) \quad W_{||}^0(z) \xleftrightarrow{\mathcal{F}} Z_{||}^0(\omega)$$

$$\Delta E_{\text{beam1}}(s) + \Delta E_{\text{beam2}}(s) =$$

$$\frac{4e^2\omega_0}{\pi} \sum_{p=0}^{\infty} |\Lambda(p\omega_0)|^2 \left\{ \text{Re} \left[Z_{||}^0(p\omega_0) \right] + [y_1(s) + y_2(s)] \text{Re} \left[Z_{||}^1(p\omega_0) \right] \right\} \cdot \sin^2 \left(\frac{p\omega_0 s}{c} \right)$$

$$\Delta W_{CC} = \frac{\omega_0}{2\pi} \int_{-s_0}^{s_0} [\Delta E_{\text{beam1}}(s) + \Delta E_{\text{beam2}}(s)] ds$$

Beam energy loss in the LHC triplets

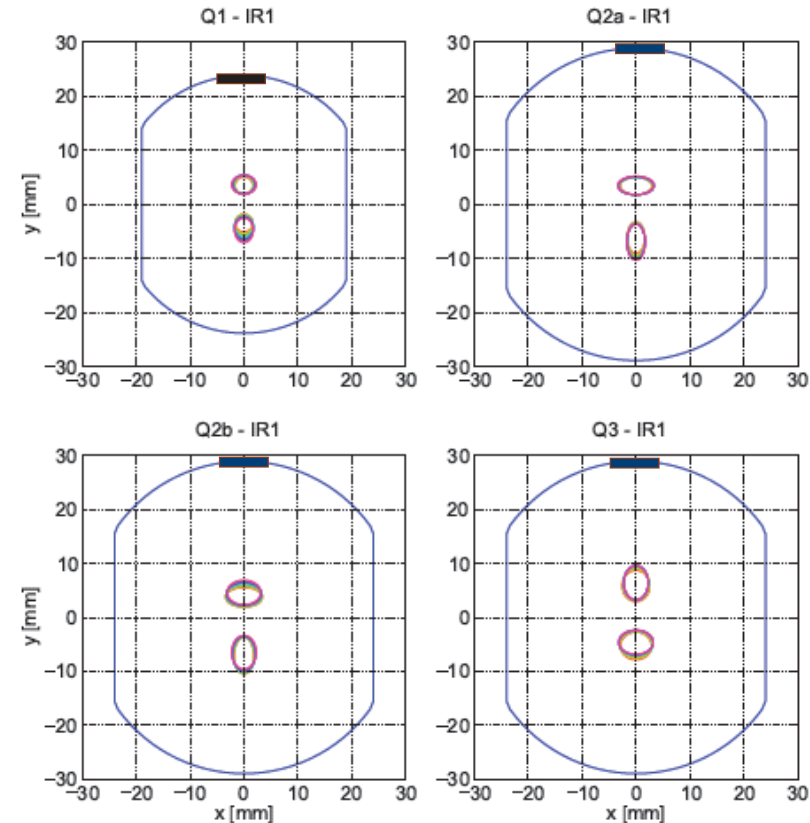
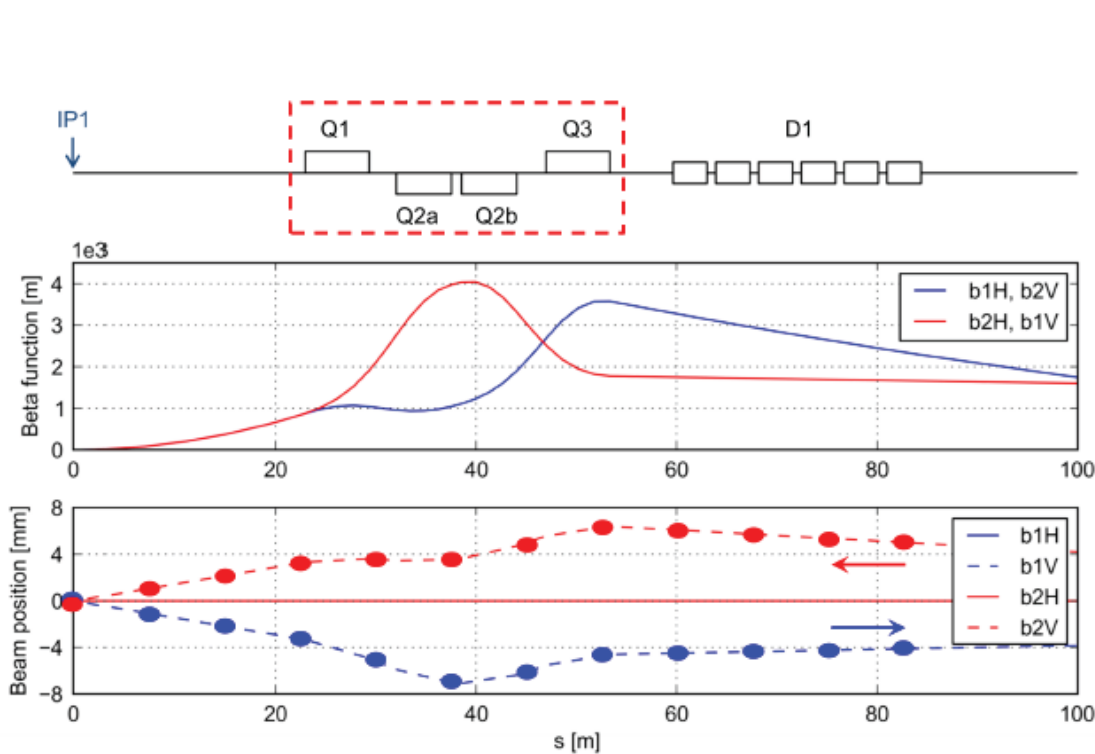

- Application to the LHC inner triplets

- Beams are separated vertically (IP1) or horizontally (IP5)
- Strongly off-axis for ~30m, all relative delays between beams swept
- Asymmetric chamber in the direction of separation because of the weld

Beam energy loss in the LHC triplets

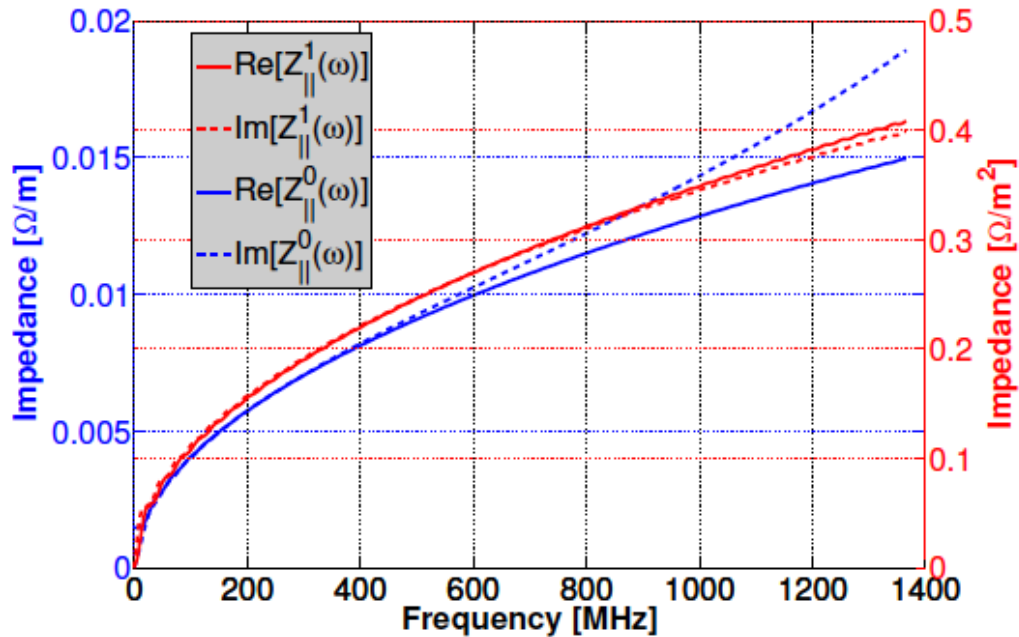

$$\Delta W_{IT} = 4 \text{ W}$$

for a typical 50 ns fill of the LHC

Beam energy loss in the LHC triplets

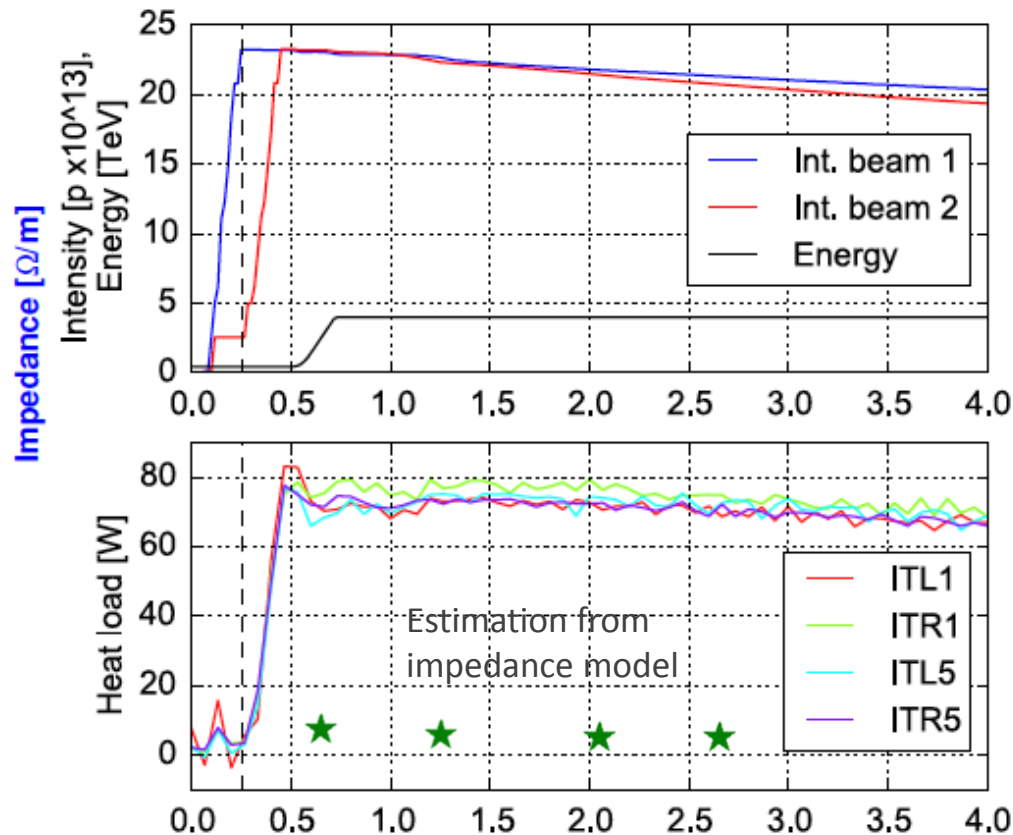

- Comparison with measured data (L. Taviano)

- Estimated heat load more than a factor 10 below measurement

- Indication of a dominant contribution from electron cloud, also enhanced by the two-beam effect for a typical 50 ns fill of the LHC

Panofsky-Wenzel Theorem

Relation between transverse and longitudinal wakes (Panofsky-Wenzel theorem)

$$\nabla \cdot \vec{E} = \frac{\rho}{\epsilon_0} \qquad \nabla \cdot \vec{B} = 0$$

$$\nabla \times \vec{B} = \mu_0 \vec{j} + \mu_0 \epsilon_0 \frac{\partial \vec{E}}{\partial t} \qquad \nabla \times \vec{E} = -\frac{\partial \vec{B}}{\partial t}$$

Source terms (displaced point charge traveling along s with speed v) in Cartesian coordinates:

$$\rho(x, y, s, t) = q_1 \delta(x - x_1) \delta(y - y_1) \delta(s - vt)$$

$$\vec{j}(x, y, s, t) = \rho(x, y, s, t) \vec{v}$$

Relation between transverse and longitudinal wakes (Panofsky-Wenzel theorem)

$$\nabla \cdot \vec{E} = \frac{\rho}{\epsilon_0} \qquad \nabla \cdot \vec{B} = 0$$

$$\nabla \times \vec{B} = \mu_0 \vec{j} + \mu_0 \epsilon_0 \frac{\partial \vec{E}}{\partial t} \qquad \nabla \times \vec{E} = -\frac{\partial \vec{B}}{\partial t}$$

Source terms (displaced point charge traveling along s with speed v) in cylindrical coordinates:

$$\begin{aligned} \rho(r, \theta, s, t) &= \frac{q_1}{r_1} \delta(r - r_1) \delta_P(\theta) \delta(s - vt) = \\ &= \frac{q_1}{r_1} \delta(r - r_1) \delta(s - vt) \sum_{m=0}^{\infty} \frac{\cos m\theta}{\pi(1 + \delta_{m0})} \end{aligned}$$

$$\vec{j}(r, \theta, s, t) = \rho(r, \theta, s, t) \vec{v}$$

$$v = \beta c \quad \text{with} \quad \beta \approx 1$$

Relation between transverse and longitudinal wakes (Panofsky-Wenzel theorem)

$$\frac{\partial E_x}{\partial x} + \frac{\partial E_y}{\partial y} + \frac{\partial E_s}{\partial s} = \frac{\rho}{\epsilon_0}$$

$$\frac{\partial B_x}{\partial x} + \frac{\partial B_y}{\partial y} + \frac{\partial B_s}{\partial s} = 0$$

$$\frac{\partial B_s}{\partial y} - \frac{\partial B_y}{\partial s} - \frac{1}{c^2} \frac{\partial E_x}{\partial t} = 0$$

$$\frac{\partial E_s}{\partial y} - \frac{\partial E_y}{\partial s} + \frac{\partial B_x}{\partial t} = 0$$

$$\frac{\partial B_x}{\partial s} - \frac{\partial B_s}{\partial x} - \frac{1}{c^2} \frac{\partial E_y}{\partial t} = 0$$

$$\frac{\partial E_x}{\partial s} - \frac{\partial E_s}{\partial x} + \frac{\partial B_y}{\partial t} = 0$$

$$\frac{\partial B_y}{\partial x} - \frac{\partial B_x}{\partial y} - \frac{1}{c^2} \frac{\partial E_s}{\partial t} = \mu_0 \rho c$$

$$\frac{\partial E_y}{\partial x} - \frac{\partial E_x}{\partial y} + \frac{\partial B_s}{\partial t} = 0$$

Relation between transverse and longitudinal wakes (Panofsky-Wenzel theorem)

We want to find relations between the forces on the witness charge:

$$\vec{F}_{\perp} = q_2[(E_x - cB_y)\hat{x} + (E_y + cB_x)\hat{y}]$$

$$F_s = q_2 E_s$$

with

$$s - ct = z$$



$$\frac{\partial}{\partial s} = \frac{\partial}{\partial z} = -\frac{1}{c} \frac{\partial}{\partial t}$$

Relation between transverse and longitudinal wakes (Panofsky-Wenzel theorem)

$$\frac{\partial E_x}{\partial x} + \frac{\partial E_y}{\partial y} + \frac{\partial E_s}{\partial s} = \frac{\rho}{\epsilon_0}$$

$$\frac{\partial B_x}{\partial x} + \frac{\partial B_y}{\partial y} + \frac{\partial B_s}{\partial s} = 0$$

$$\frac{\partial B_s}{\partial y} - \frac{\partial B_y}{\partial s} - \frac{1}{c^2} \frac{\partial E_x}{\partial t} = 0$$

$$\frac{\partial B_x}{\partial s} - \frac{\partial B_s}{\partial x} - \frac{1}{c^2} \frac{\partial E_y}{\partial t} = 0$$

$$\frac{\partial B_y}{\partial x} - \frac{\partial B_x}{\partial y} - \frac{1}{c^2} \frac{\partial E_s}{\partial t} = \mu_0 \rho c$$

We first use this set of equations

$$\frac{\partial E_s}{\partial y} - \frac{\partial E_y}{\partial s} + \frac{\partial B_x}{\partial t} = 0$$

$$\frac{\partial E_x}{\partial s} - \frac{\partial E_s}{\partial x} + \frac{\partial B_y}{\partial t} = 0$$

$$\frac{\partial E_y}{\partial x} - \frac{\partial E_x}{\partial y} + \frac{\partial B_s}{\partial t} = 0$$

Relation between transverse and longitudinal wakes (Panofsky-Wenzel theorem)

$$\frac{\partial F_x}{\partial z} - \frac{\partial F_s}{\partial x} = 0$$

$$\frac{\partial F_s}{\partial y} - \frac{\partial F_y}{\partial z} = 0$$

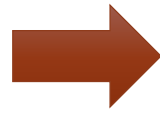

$$\frac{\partial \vec{F}_\perp}{\partial z} = \nabla_\perp F_s$$

$$\frac{\partial \int_0^L \vec{F}_\perp ds}{\partial z} = \nabla_\perp \int_0^L F_s ds$$

Result known as Panofsky-Wenzel theorem

Relation between transverse and longitudinal wakes (Panofsky-Wenzel theorem)

$$\frac{\partial \int_0^L \vec{F}_\perp ds}{\partial z} = \nabla_\perp \int_0^L F_s ds$$

$$\int_0^L F_x ds = W_x(z) \Delta x_1 + W_{Qx}(z) x$$



$$W'_x(z) = W_{||}^{(dq)}(z) \quad \stackrel{\mathcal{F}}{\iff} \quad \frac{\omega}{c} Z_x(\omega) = Z_{||}^{(dq)}(\omega)$$

$$W'_{Qx}(z) = 2W_{||}^{(2q)}(z) \quad \stackrel{\mathcal{F}}{\iff} \quad \frac{\omega}{c} Z_{Qx}(\omega) = 2Z_{||}^{(2q)}(\omega)$$

Relation between transverse and longitudinal wakes (Panofsky-Wenzel theorem)

$$\frac{\partial \int_0^L \vec{F}_\perp ds}{\partial z} = \nabla_\perp \int_0^L F_s ds$$

$$\int_0^L F_x ds = W_x(z) \Delta x_1 + W_{Qx}(z) x$$



The longitudinal and transverse wake functions are not independent, although in general no relation can be established between $W_{||}(z)$ and $W_{x,y}(z)$, which are the main wakes in the longitudinal and transverse planes, respectively.

$$W'_x(z) = V_{||}^{(dq)}(\omega)$$

$$W'_{Qx}(z) = 2W_{||}^{(2q)}(z) \quad \xleftrightarrow{\mathcal{F}} \quad \frac{\omega}{c} Z_{Qx}(\omega) = 2Z_{||}^{(2q)}(\omega)$$

Relation between transverse and longitudinal wakes (Panofsky-Wenzel theorem)

$$\frac{\partial E_x}{\partial x} + \frac{\partial E_y}{\partial y} + \frac{\partial E_s}{\partial s} = \frac{\rho}{\epsilon_0}$$

$$\frac{\partial B_x}{\partial x} + \frac{\partial B_y}{\partial y} + \frac{\partial B_s}{\partial s} = 0$$

$$\frac{\partial B_s}{\partial y} - \frac{\partial B_y}{\partial s} - \frac{1}{c^2} \frac{\partial E_x}{\partial t} = 0$$

$$\frac{\partial E_s}{\partial s} - \frac{\partial E_y}{\partial t} + \frac{\partial B_x}{\partial t} = 0$$

$$\frac{\partial B_x}{\partial s} - \frac{\partial B_s}{\partial x} - \frac{1}{c^2} \frac{\partial E_s}{\partial t}$$

We can now use also these two sets of equations to find additional properties of the wakes

$$\frac{\partial E_s}{\partial s} - \frac{\partial E_x}{\partial t} + \frac{\partial B_y}{\partial t} = 0$$

$$\frac{\partial B_y}{\partial x} - \frac{\partial B_x}{\partial y} - \frac{1}{c^2} \frac{\partial E_s}{\partial t} = \mu_0 \rho c$$

$$\frac{\partial E_y}{\partial x} - \frac{\partial E_x}{\partial y} + \frac{\partial B_s}{\partial t} = 0$$

Relation between transverse and longitudinal wakes (Panofsky-Wenzel theorem)

$$\frac{\partial F_x}{\partial x} = -\frac{\partial F_y}{\partial y}$$



$$W_{Qx}(z) = -W_{Qy}(z)$$

This is an interesting result!
The quadrupolar wakes in x and y must be equal with opposite signs

$$\frac{\partial \int_0^L F_x ds}{\partial x} = -\frac{\partial \int_0^L F_y ds}{\partial y}$$

$$\frac{\partial F_x}{\partial y} = \frac{\partial F_y}{\partial x}$$

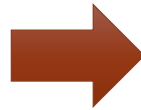

This relation means that the cross-wakes between x and y must be equal.
We have so far ignored these terms in our derivations.

$$\frac{\partial \int_0^L F_x ds}{\partial y} = \frac{\partial \int_0^L F_y ds}{\partial x}$$

Instabilities

- The **equilibrium distribution** in the presence of a longitudinal wake field can be found analytically. The (linearized) **longitudinal Hamiltonian** with longitudinal wake fields is given as:

$$H = -\frac{1}{2}\eta\delta^2 - \frac{1}{2\eta}\left(\frac{\omega_s}{\beta c}\right)^2 z^2 + \frac{e^2}{\beta^2 EC} \sum_k \int dz'' \int dz' \lambda(z' + kC) W_0'(z'' - z' - kC)$$

- Remember the example of the harmonic oscillator:

$$H = \frac{1}{2} p^2 + \frac{1}{2} \boxed{W} q^2$$

↓

Coefficient determines frequency/tune

- The **equilibrium distribution** in the presence of a longitudinal wake field can be found analytically. The (linearized) **longitudinal Hamiltonian** with longitudinal wake fields is given as:

$$H = -\frac{1}{2}\eta\delta^2 - \frac{1}{2\eta}\left(\frac{\omega_s}{\beta c}\right)^2 z^2 + \underbrace{\frac{e^2}{\beta^2 EC} \sum_k \int dz'' \int dz' \lambda(z' + kC) W_0'(z'' - z' - kC)}_{\text{we make an expansion in } z - \text{factor out } \frac{1}{2\eta\beta^2 c^2}}$$

we make an expansion in z – factor out $\frac{1}{2\eta\beta^2 c^2}$

- Remember the example of the harmonic oscillator:

$$H = \frac{1}{2} p^2 + V q + \frac{1}{2} W q^2$$

Term determines center position/orbit

Coefficient determines frequency/tune

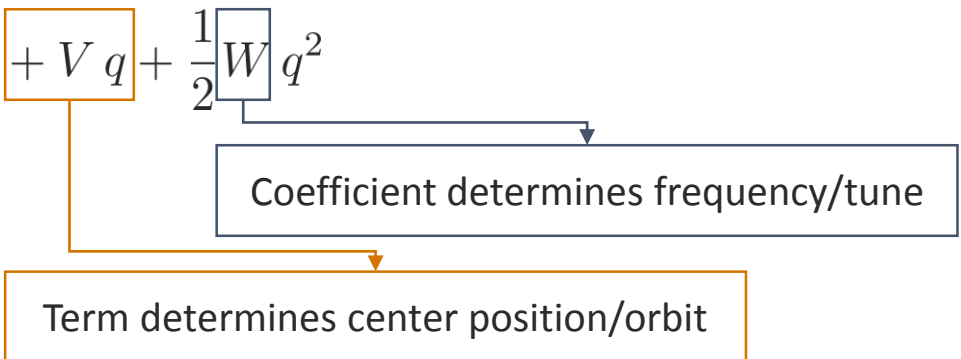

- The **equilibrium distribution** in the presence of a longitudinal wake field can be found analytically. The (linearized) **longitudinal Hamiltonian** with longitudinal wake fields is given as:

$$H = -\frac{1}{2}\eta\delta^2 - \frac{1}{2\eta}\left(\frac{\omega_s}{\beta c}\right)^2 z^2 + \underbrace{\frac{e^2}{\beta^2 EC} \sum_k \int dz'' \int dz' \lambda(z'+kC)W'_0(z''-z'-kC)}_{\text{expansion in } z - \text{factor } \frac{1}{2\eta\beta^2 c^2}}$$

- It follows then quite easily that:

$$\begin{aligned}\Delta\omega_s &\approx -\frac{1}{2\omega_s} \frac{e^2 \eta c^2}{EC} \int dz' \lambda(z')W''_0(z-z') \\ &= -\frac{i}{4\pi} \frac{e^2 \eta c^2}{\omega_s EC} \int d\omega \hat{\lambda}(\omega)Z_0(\omega)\frac{\omega}{c}\end{aligned}$$

Remember, we make use of:
 $\Omega^2 - \omega_s^2 \approx 2\omega_s \Delta\omega_s$

- The synchrotron tune shift from an impedance is, hence, given as:

$$\Delta Q_s = -\frac{1}{4\omega_s} \frac{e^2 \eta}{(2\pi^2)E} \int d\omega \omega \hat{\lambda}(\omega) \text{Im}[Z_0(\omega)]$$

Measurements of synchrotron tune shift at SPS

- The slope of the **incoherent synchrotron tune shift with intensity**, measured in reproducible conditions over the years, shows the evolution of the **imaginary part of the machine impedance** (E. Shaposhnikova, T. Bohl, J. Tuckmantel)
 - The technique uses the quadrupole oscillations of a bunch injected with a mismatch
 - Qs can be extrapolated from bunch length or peak amplitude measurements

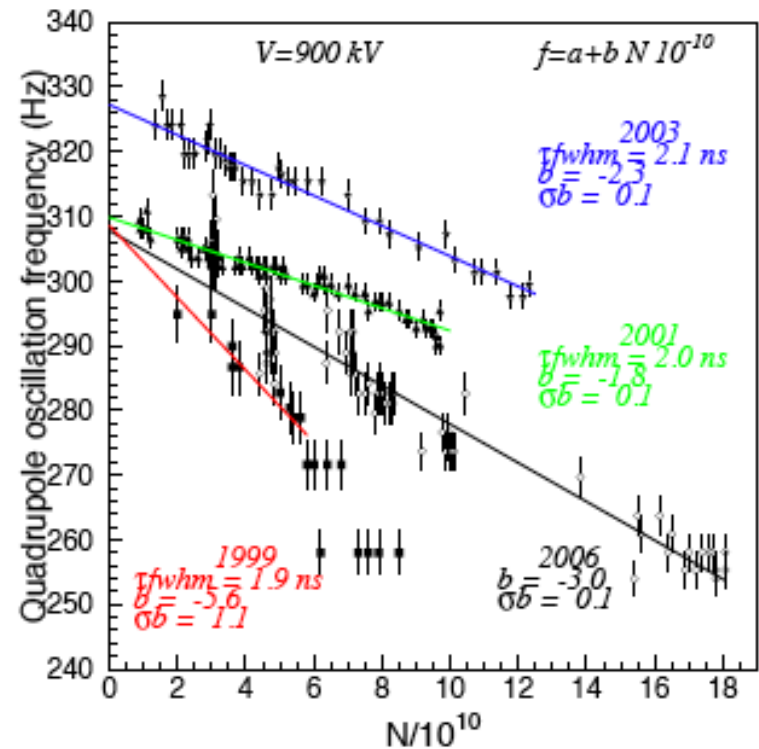
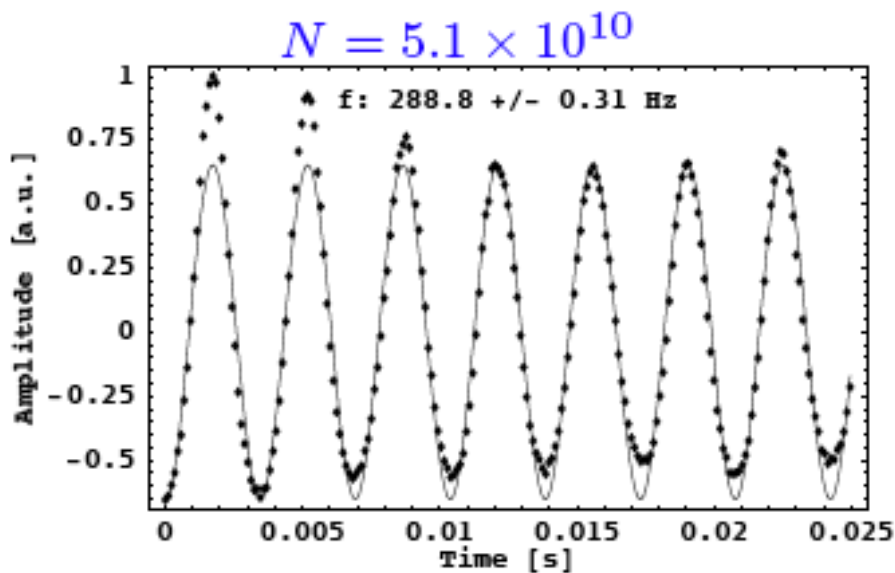

Measurements of potential well distortion

Stable phase and bunch lengthening

Measurements at light sources

⇒ Bunch lengthening @DIAMOND (left, R. Bartolini)

⇒ Energy loss measured through the synchronous phase shift @Australian light source (right, R. Dowd, M. Boland, G. LeBlanc, M. Spencer, Y. Tan, PAC07)

bunch lengthening: voltage 2.0 MV

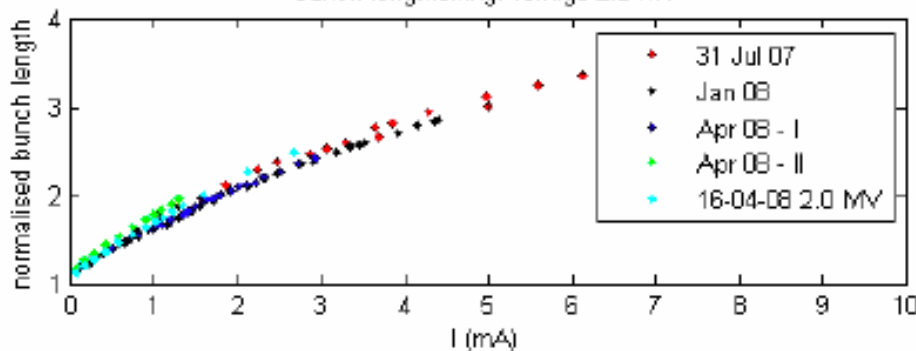

energy spread widening

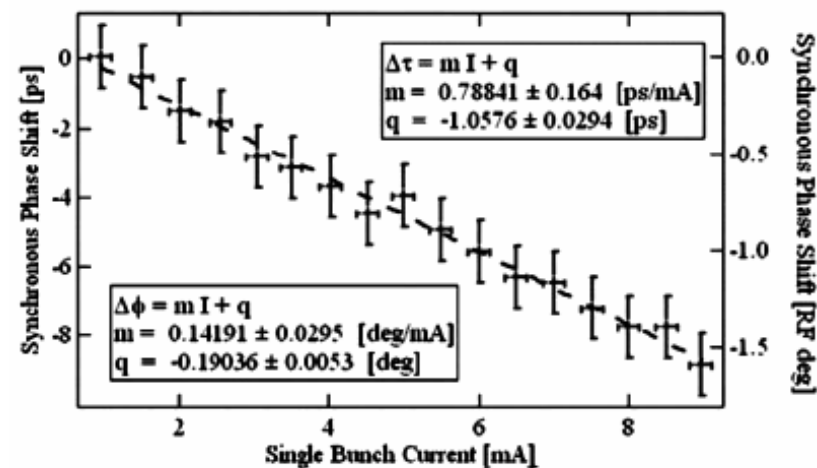
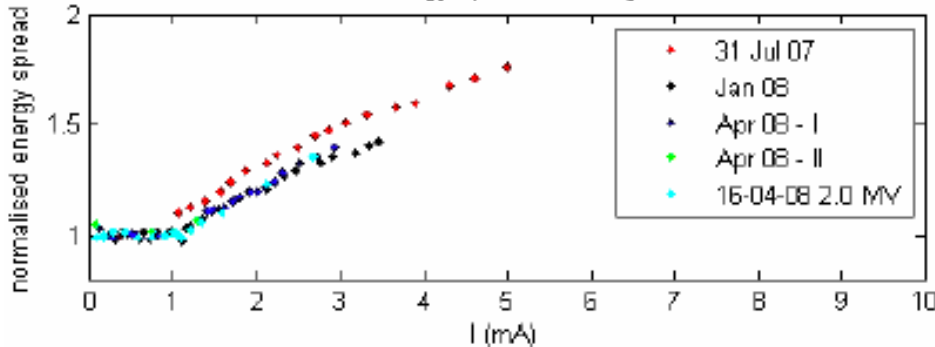

Synchronous phase shift measured with a streak camera in the Australian Synchrotron.

Examples of numerical simulations debunching bunch with SPS impedance model

Microwave instability on a debunching bunch is used at SPS for probing the machine impedance
(E. Shaposhnikova, T. Bohl, H. Timkó, et al.)

⇒ Long bunch injected into SPS with RF off slowly debunches due to low momentum spread

⇒ Spectrum of bunch profile reveals important components for the impedance

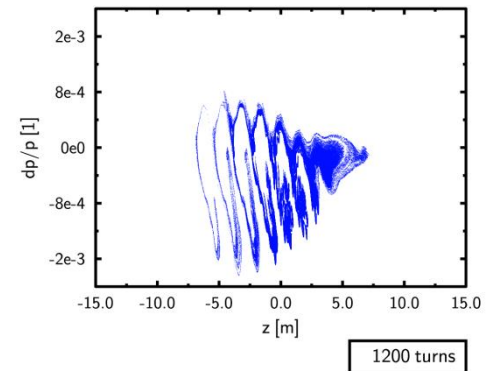
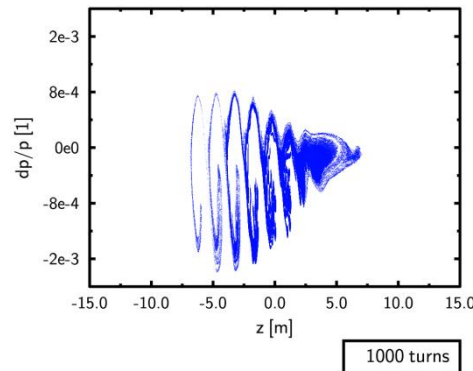
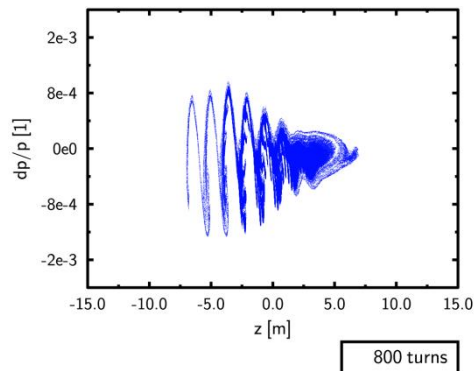
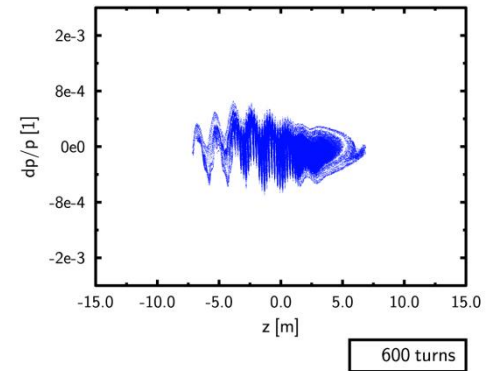
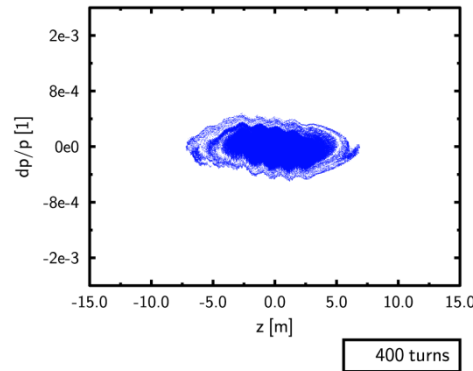
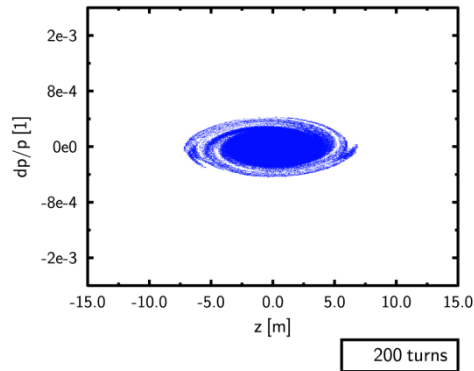

Examples of numerical simulations debunching bunch with SPS impedance model

Microwave instability on a debunching bunch is used at SPS for probing the machine impedance (E. Shaposhnikova, T. Bohl, H. Timkó, et al.)

- ⇒ Long bunch injected into SPS with RF off slowly debunches due to low momentum spread
- ⇒ Spectrum of bunch profile reveals important components for the impedance
- ⇒ Simulations with impedance model are used to match measured profile

